

PART NUMBER	ITEM ① BODY	ITEM ② NUT	ITEM ③ CONTACT	ITEM ④ INSULATOR	ITEM ⑤ RETENTION SPRING	ITEM ⑥ CRIMP SLEEVE	REMARKS
142-0407-011	BRASS GOLD PL .00001 MIN OVER NICKEL PL .00005 MIN OVER COPPER PL .00005 MIN	BRASS GOLD PL .00001 MIN OVER NICKEL PL .00005 MIN OVER COPPER PL .00005 MIN	BRASS GOLD PL .00005 MIN OVER NICKEL PL .00005 MIN OVER COPPER PL .00005 MIN	TEFLON	BERYLLIUM COPPER UNPLATED	COPPER GOLD PL .00001 MIN OVER NICKEL PL .00005 MIN OVER COPPER PL .00005 MIN	
142-0407-012	COPPER GOLD PL .00005 MIN OVER COPPER PL .00005 MIN	COPPER GOLD PL .00005 MIN OVER COPPER PL .00005 MIN	COPPER GOLD PL .00005 MIN OVER COPPER PL .00005 MIN	TEFLON	BERYLLIUM COPPER UNPLATED	COPPER GOLD PL .00005 MIN OVER COPPER PL .00005 MIN	OBSOLETE REPLACED BY 142-9407-001
142-0407-013	BRASS GOLD PL .00005 MIN OVER COPPER PL .00005 MIN	BRASS GOLD PL .00005 MIN OVER COPPER PL .00005 MIN	BRASS GOLD PL .00005 MIN OVER COPPER PL .00005 MIN	TEFLON	BERYLLIUM COPPER UNPLATED	COPPER GOLD PL .00005 MIN OVER COPPER PL .00005 MIN	
142-0407-014	COPPER SILVER PL .00005 MIN OVER COPPER PL .000075 MIN	COPPER SILVER PL .00005 MIN OVER COPPER PL .000075 MIN	COPPER SILVER PL .00005 MIN OVER COPPER PL .000075 MIN	TEFLON	BERYLLIUM COPPER UNPLATED	COPPER SILVER PL .00005 MIN OVER COPPER PL .000075 MIN	OBSOLETE REPLACED BY 142-9407-001
142-0407-015	BRASS SILVER PL .00005 MIN OVER COPPER PL .000075 MIN	BRASS SILVER PL .00005 MIN OVER COPPER PL .000075 MIN	BRASS SILVER PL .00005 MIN OVER COPPER PL .000075 MIN	TEFLON	BERYLLIUM COPPER UNPLATED	COPPER SILVER PL .00005 MIN OVER COPPER PL .000075 MIN	
142-0407-016	BRASS NICKEL PL .0001 MIN OVER COPPER PL .00005 MIN	BRASS NICKEL PL .0001 MIN OVER COPPER PL .00005 MIN	BRASS GOLD PL .00005 MIN OVER NICKEL PL .00005 MIN OVER COPPER PL .00005 MIN	TEFLON	BERYLLIUM COPPER UNPLATED	COPPER NICKEL PL .0001 MIN OVER COPPER PL .00005 MIN	

DRAWING NO. C - 142-0407-011/020	
0	REVISIONS
ENGINEERING RELEASE	
1	6-15-92 R H T A R J B H E M 6-30-92 ECO 41115
ADDED: P/N 142-0407-011	
2	7-19-93 R H R P A H 7-22-93 ECO 41953
VERSION UPDATE	
2a	4-20-95 R H S W K A R J B A H 6-1-95 ECN 43206
ADDED: P/N 142-0407-012	
2b	12-8-98 R H R J B A 46068
CHANGED: 142-0407-012 AND -014 ITEMS 1, 2 AND 3 COPPER WAS BRASS	
2c	6-11-99 R H R J B A 46404
ADDED: P/N 142-0407-013	
2d	2-22-00 R H R J F 3-1-00 ECN 47002
ADDED: P/N 142-0407-015	
2e	3-30-00 R H R J F 4-4-00 ECN 47046
VERSION UPDATE	
2f	5-30-00 R H K A S J B H E M 8-2-00 ECN 47098
ADDED: CRIMP TOOL P/N'S	
***** * REVISION NUMBER FOLLOWED BY AN ALPHA * * CHARACTER INDICATES DRAWING CLARIFI- * * CATION OR PART NUMBER ADDITION ONLY. * *****	
2g	12-7-00 R H R J A R J B K 47445
ADDED OBSOLETE REMARKS	
3	3-15-10 C W S D R M J B J U 3-15-10 ECO 52203

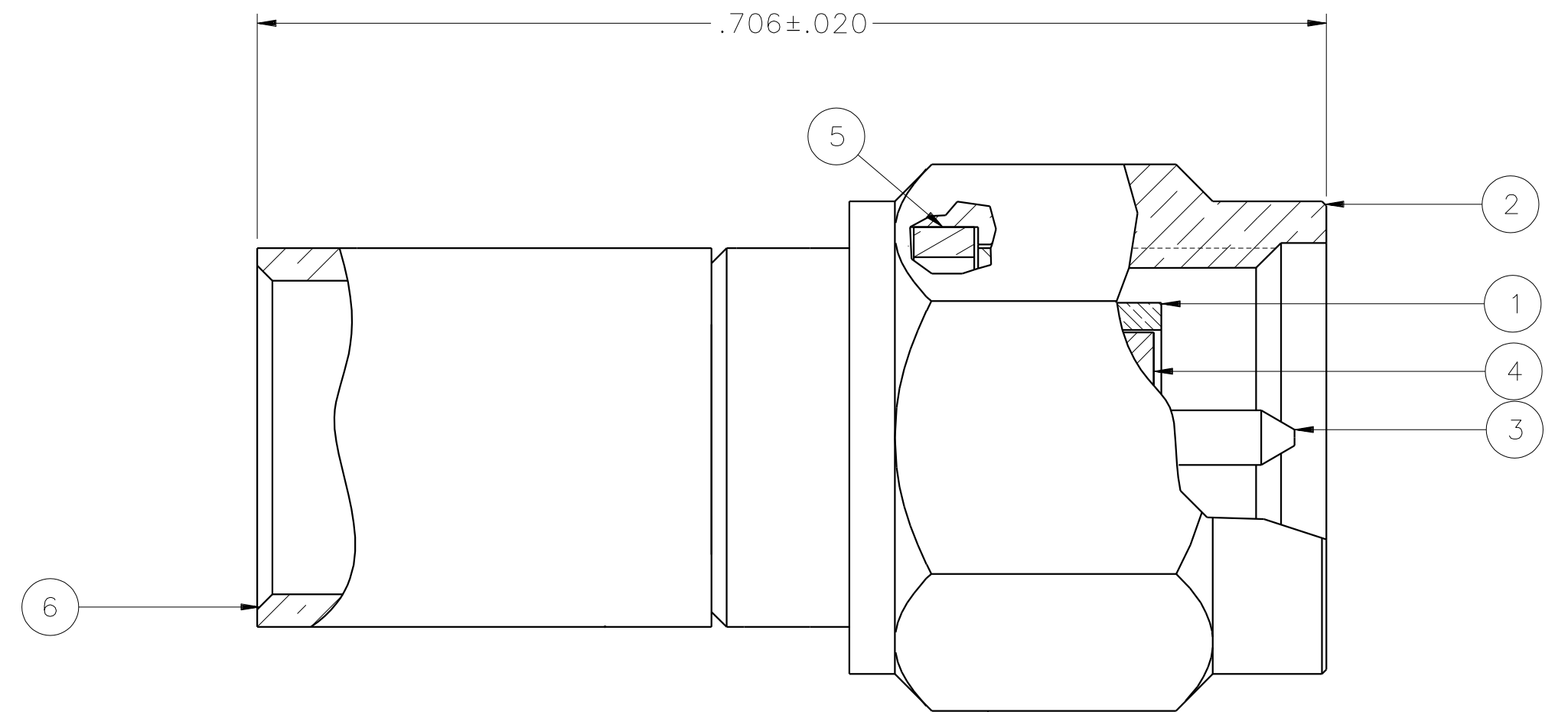

NOTES:

1. SPECIFICATIONS:

IMPEDANCE: 50 OHMS
 FREQUENCY RANGE: 0-12.4 GHz
 VSWR: 1.15+.01F MAX (F IN GHz)
 WORKING VOLTAGE: 335 VRMS MAX AT SEA LEVEL
 DIELECTRIC WITHSTANDING VOLTAGE: 1000 VRMS MIN AT SEA LEVEL
 INSULATION RESISTANCE: 5000 MEGOHM MIN
 CONTACT RESISTANCE:
 CENTER CONTACT - INITIAL 3.0 MILLIOHM MAX, AFTER ENVIRONMENTAL 4.0 MILLIOHM MAX
 OUTER CONDUCTOR - INITIAL 2.0 MILLIOHM MAX AFTER ENVIRONMENTAL NOT APPLICABLE
 BODY TO CABLE - 0.5 MILLIOHM MAX (GOLD PLATED & SILVER PLATED) 5.0 MILLIOHM MAX (NICKEL PLATED)
 CORONA LEVEL: 250 VOLTS MIN AT 70,000 FEET
 INSERTION LOSS: .06 √F MAX (F IN GHz) AT 6 GHz
 RF LEAKAGE: -60 DB MIN AT 2.5 GHz
 RF HIGH POTENTIAL WITHSTANDING VOLTAGE: 670 VRMS MIN AT 4 AND 7 MHZ

MECHANICAL:

ENGAGE/DISENGAGE TORQUE: 2 INCH-POUNDS MAX
 MATING TORQUE: 7-10 INCH POUNDS
 COUPLING PROOF TORQUE: 15 INCH-POUNDS MIN
 COUPLING NUT RETENTION: 60 LBS MIN
 CONTACT RETENTION: 6 LBS MIN AXIAL FORCE
 CABLE ACCEPTABILITY: RG 58/U, RG 141/U, RG 303/U,
 CABLE HEX CRIMP SIZE: .213
 CONTACT CRIMP TOOL: P/N 144-0000-910 WITH POSTIONER 141-0000-007
 CABLE RETENTION: 40 LBS MIN AXIAL FORCE
 DURABILITY: 500 CYCLES MIN

ENVIRONMENTAL:

(MEETS OR EXCEEDS THE APPLICABLE PARAGRAPH OF MIL-PRF-39012)
 THERMAL SHOCK: MIL-STD-202, METHOD 107, CONDITION B, EXCEPT 85° C HIGH TEMP
 OPERATING TEMPERATURE: -65° C TO 165° C
 CORROSION: MIL-STD-202, METHOD 101, CONDITION B
 SHOCK: MIL-STD-202, METHOD 213, CONDITION I
 VIBRATION: MIL-STD-202, METHOD 204, CONDITION D
 MOISTURE RESISTANCE: MIL-STD-202, METHOD 106

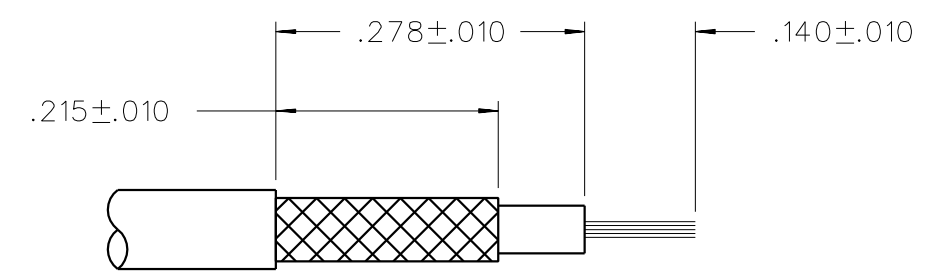

CABLE STRIP DIMENSIONS
4:1

CUSTOMER DRAWING

THIS DRAWING TO BE INTERPRETED PER ASME Y 14.5M - 1994

"μSTATION"

COMPANY CONFIDENTIAL

TOLERANCE UNLESS OTHERWISE SPECIFIED	DRAWN BY TAK	DATE 2-26-92	TITLE PLUG ASSEMBLY, STRAIGHT CABLED SMA, RG 58
DECIMALS	CHECKED BY TAK	DATE 6-25-92	
MATL	APPROVED BY RJB	DATE 6-26-92	
FINISH	RELEASE DATE	6-30-92	
	U/M INCH	SCALE 10:1	
SHEET 2 OF 2			DRAWING NO. C - 142-0407-011/020