

2 DEC 1998 17:19

NO. 571

P. 13/25

1/4/99 to beam

1 2 3 4 5 6 7 8

REVISIONS			
ISS	ZONE	DESCRIPTION	APPROVED DATE

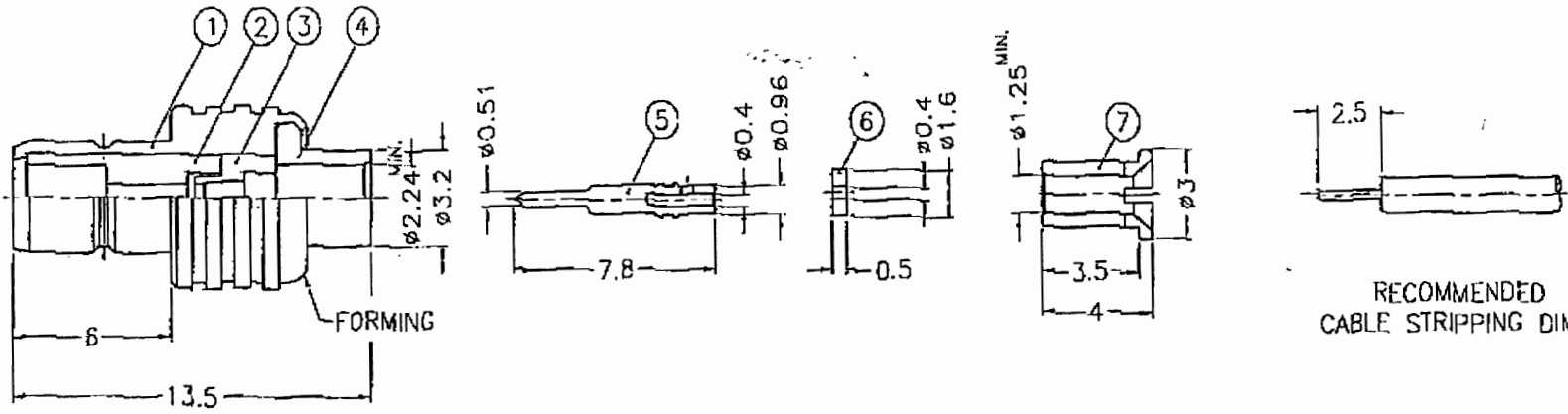

RECOMMENDED  
CABLE STRIPPING DIM'S

- NOTES: FINISH (PLATING THICKNESS IN MICRO-INCHES)
- BRASS PER QQ-B-625
  - GOLD PL. 3 MIN. THICK OVER NICKEL PL. 100 MIN. THICK OVER COPPER STRIKE
  - GOLD PL. 30 MIN. THICK OVER NICKEL PL. 100 MIN. THICK OVER COPPER STRIKE
  - TEFLON MIL-P-19468



NO.	DESCRIPTION	MATERIAL	FINISH	Q'TY	DRAWING NO.
7	SOLDER BARREL	NOTE 1	NOTE 2	1	SMB1181A1-7
6	INSULATOR	NOTE 4	NATURAL	1	SMB1181A1-5T-5D
5	CONTACT PIN	NOTE 1	NOTE 3	1	SMB1121A1-5-C26/D4
4	BARREL	NOTE 1	NOTE 2	1	SMB6181A1-4-32/224-E
3	INSULATOR	NOTE 4	NATURAL	1	SMB6121B2-3T-5C
2	INSULATOR	NOTE 4	NATURAL	1	SMB1121A1-2T-5D
1	BODY	NOTE 1	NOTE 2	1	SMB1121A1-1-B

DIMENSIONS ARE IN MILLIMETERS		PART NO.		KAI JACK INDUSTRIAL CO., LTD.	
UNLESS OTHERWISE SPECIFIED TOLERANCES		142225		TAINAN TAIWAN R.O.C.	
0.5-5	±0.2	APPROVED	DATE	TITLE	
6-30	±0.4	<i>Golden</i>	11-10-98	SMB DIRECT SOLDER JACK	
30-120	±0.5	CHECKED	DATE	(FOR .047") SIMILRIGID CABLE	
120-115	±1	<i>Golden</i>	11-10-98	DRAWING NO. 142225	
315-1000	±1.5	DRAWN	DATE	KJ-SMB1181A1-3GTJG-047-50	
1000-2000	±2.4	KOLI	11-10-98	FILE NO. F:\DWG\5MB\1181A1\047-50\3GT50G	

12/02/98 02:11

TX/RX NO. 6410

P. 013

F  
E  
D  
C  
B  
A

1 2 3 4 5 6 7 8