

MODEL NO.	PACKAGING
148-0701-212	ONE PCS PER BAG

REV	ECO	DATE
001	ECO-19-001	08/28/2019

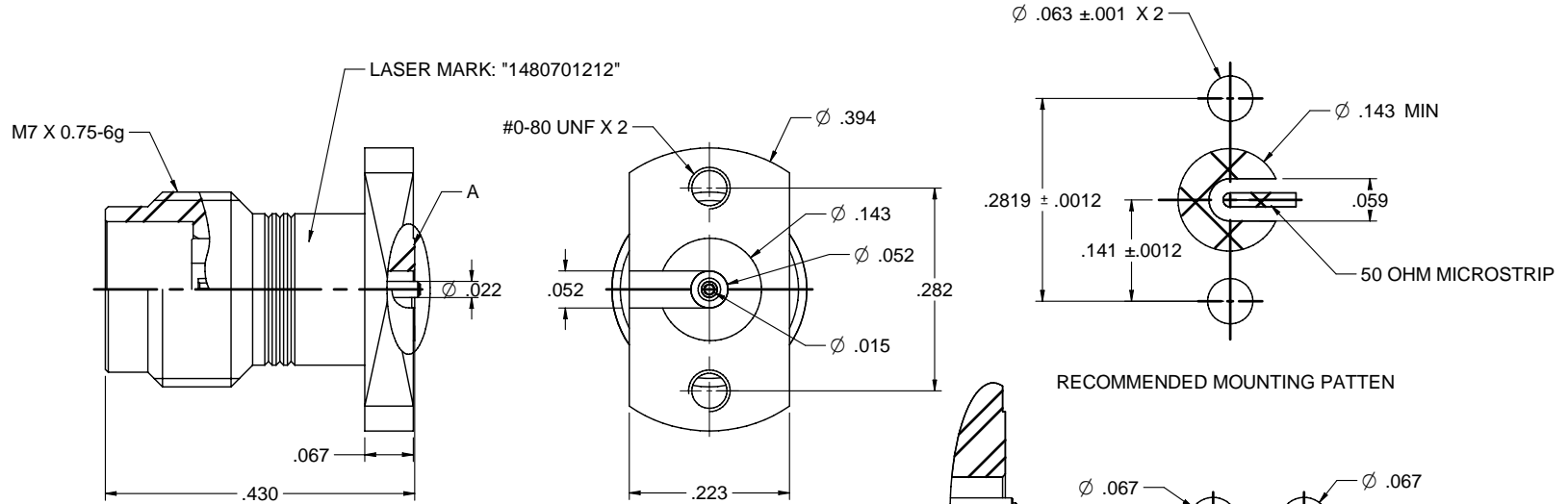

RECOMMENDED MOUNTING PATTERN

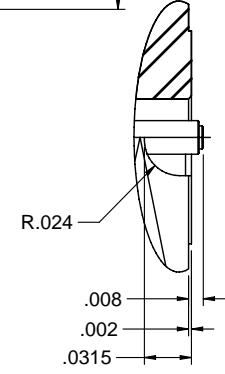
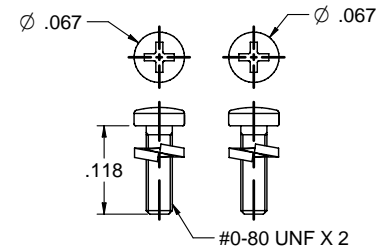

A DETAIL (10/1)

SCALE (3/1)

1. BOARD THICKNESS: 1.57-2.79mm

NOTES: UNLESS OTHERWISE SPECIFIED

1. MATERIAL & FINISH:
 - 1.1 BODY: PASSIVATED STAINLESS STEEL
 - 1.2 CONTACT PIN : GOLD PLATED BERYLLIUM COPPER
 - 1.3 INSULATOR: PTFE WHITE
 - 1.4 WASHER: STAINLESS STEEL
 - 1.5 BOLT: SUS302
 - 1.6 LOCK RING: NICKEL PLATED BRASS
2. ELECTRICAL:
 - 2.1 IMPEDANCE: 50 OHMS
 - 2.2 FREQUENCY RANGE: DC-67 GHz
 - 2.3 INSULATION RESISTANCE: 5000 MOHM MIN
 - 2.4 CONTACT RESISTANCE:
 - 2.4.1 CENTER CONTACT: 4 MILLIOHM MAX
 - 2.4.2 OUTER CONTACT: 2.5 MILLIOHM MAX
 - 2.5 DIELECTRIC WITHSTANDING VOLTAGE: 500VRMS MIN
 - 2.6 VOLTAGE STANDING WAVE RATIO (VSWR): 1.4 MAX
3. MECHANICAL:
 - 3.1 ENGAGEMENT/ DISENGAGEMENT FORCE: 0.23 NM MAX
 - 3.2 CONTACT RETENTION: 7 N MIN
 - 3.3 DURABILITY: 500 CYCLES MIN
4. ENVIRONMENT:
 - 4.1 THERMAL SHOCK: MIL-STD-202, METHOD 107, CONDITION B.
 - 4.2 OPERATING TEMPERATURE: -65 TO 165°C
 - 4.3 SHOCK: MIL-STD-202, METHOD 213, CONDITION I
 - 4.4 VIBRATION: MIL-STD-202, METHOD 204, CONDITION D
 - 4.5 MOISTURE RESISTANCE: MIL-STD-202, METHOD 106

	Model No. 148-0701-211/220	Johnson	
	RoHS2 2011/65/EU REACH 2019/1021/EC X00X = 01 ANGLE = 15°	Title: JACK, PCB, COMPRESSION MOUNT, SIDE GROOVE, 1.85mm Drawing No. 148-0701-211/220 Date: 08/28/2019 Scale: C Drawing: NONE	Rev: 001 Sheet 1 of 1