

# SERPAC 151i9V (exploded isometric)

Electronic Enclosures

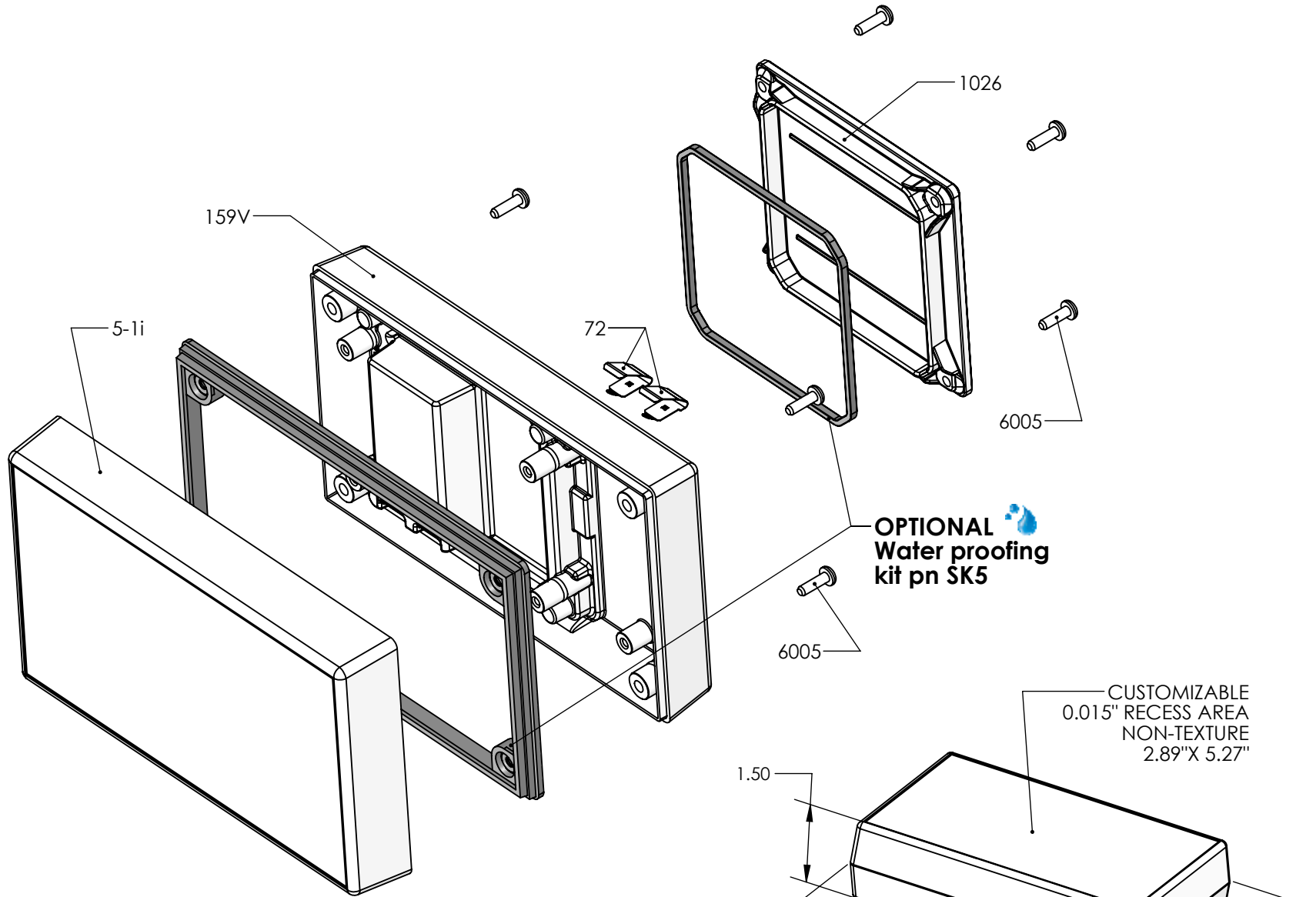

PART NO.	DESCRIPTION (Included)	ACCESSORIES (Optional)	
5-1i	Top	PART NO.	DESCRIPTION
159V	9V Bottom	50	Non-skid Feet
1026	Access Door	SK5	Seal Kit for 15X
6005	#4X3/8" Self-Tapping Screw (8)		
72	Single Battery contact (2)		

Notes:  
 Enclosure weight .31 lb / 141 g  
 1) Enclosure meets or exceeds IP40 and NEMA 1  
 2) When used with SK5 the enclosure meets or exceeds IP 67 and NEMA 4X, 12 and 13 MIL-STD-810G 506.5 (.02 lb / 141g)  
 3) Circuit Board drawings see sheet 3.  
 4) All components are RoHS Compliant.

ALL DIMENSIONS ARE ± .010" 5/3/2021 (1 of 3)  
 2009 Wright Ave. La Verne, CA 91750  
 Ph. (626) 331-0517 Fx. (626) 331-8584 serpac.com

# SERPAC 151i9V

Electronic Enclosures

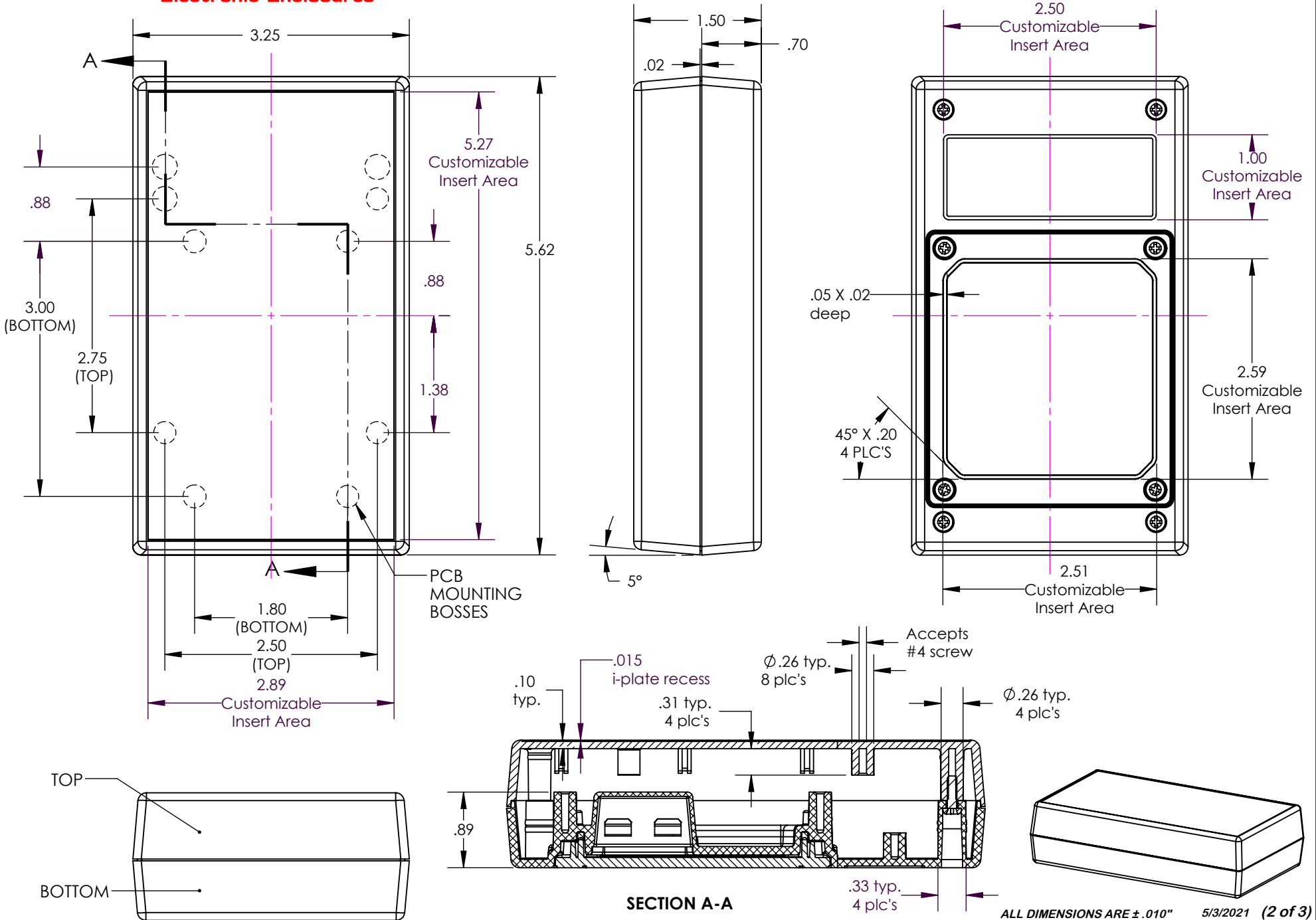

ALL DIMENSIONS ARE ±.010" 5/3/2021 (2 of 3)  
 2009 Wright Ave. La Verne, CA 91750  
 Ph. (626) 331-0517 Fx. (626) 331-8584 www.serpac.com