

Series 15250

Battery Disconnect Switch

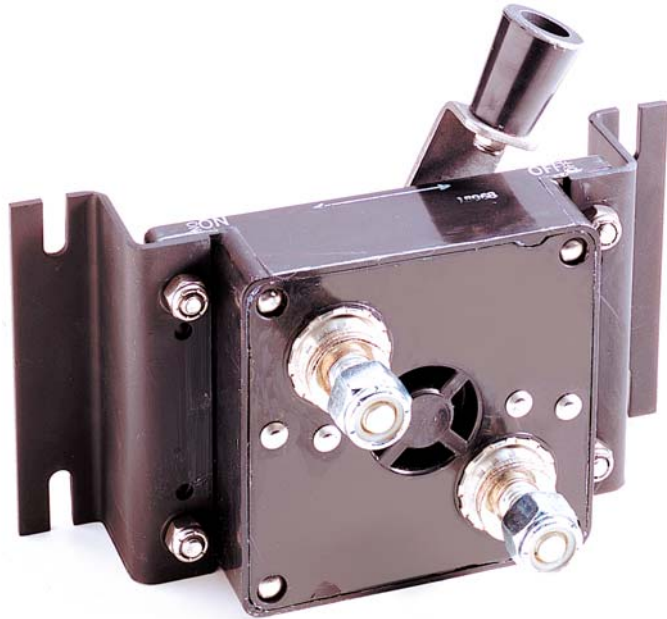

Specifications

Applications: A non-fused current interrupt disconnect designed for opening the circuit between a battery and the complete electrical load of a battery-powered system.

Rating: 400A continuous, 50Vac/Vdc. Vehicle cranking and max. surge currents to 2000A (based on 20% duty cycle with ON times of 5 seconds max.).

Temperature Rating: -40°F (-40°C) to 150°F (65°C).

Termination: 1/2-13 Copper alloy stud.

Torque Rating: 420 in-lbs (47.5N•m) max.

Mounting Torque Rating: With mounting brackets: 48 in-lbs (5.4N•m) max; without mounting brackets: 10 in-lbs (1.1N•m) max.

Options

Handles: Three handle styles available.

Other: Lubricant-filled body with silicone sealant.

Part Numbering System

Series	Handle Option	Bracket Option	Lubricant w/Sealant
15250	□	□	LR
	1	B - Bracket	(Grease Filled)
	2		
	3		

Dimensions - mm(in) (15250-1b Shown) (Dims. shown are for reference only. Consult factory for latest prints)

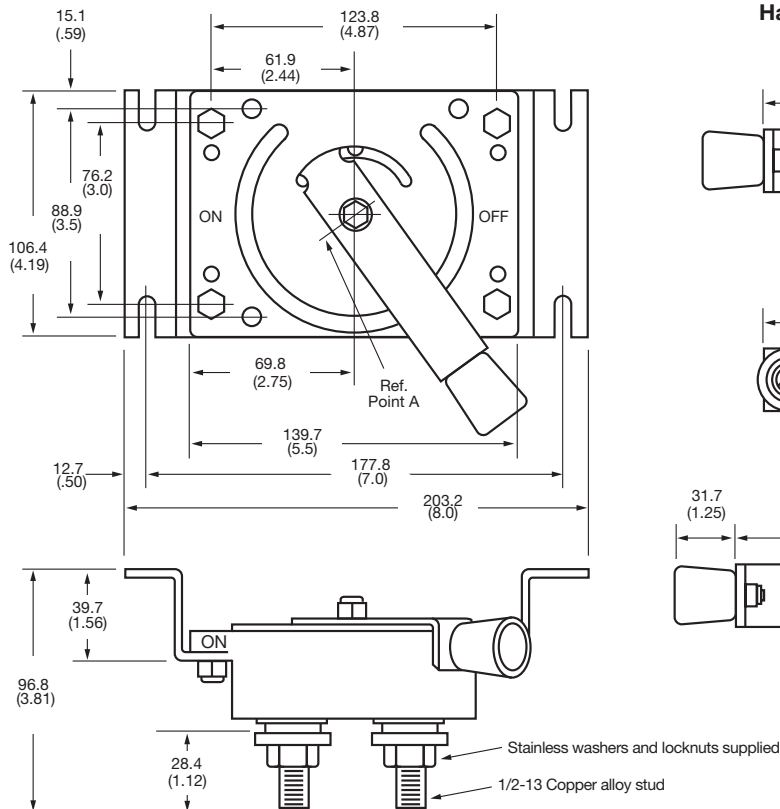

Handle Variations

