

# Series 15250

## Battery Disconnect Switch

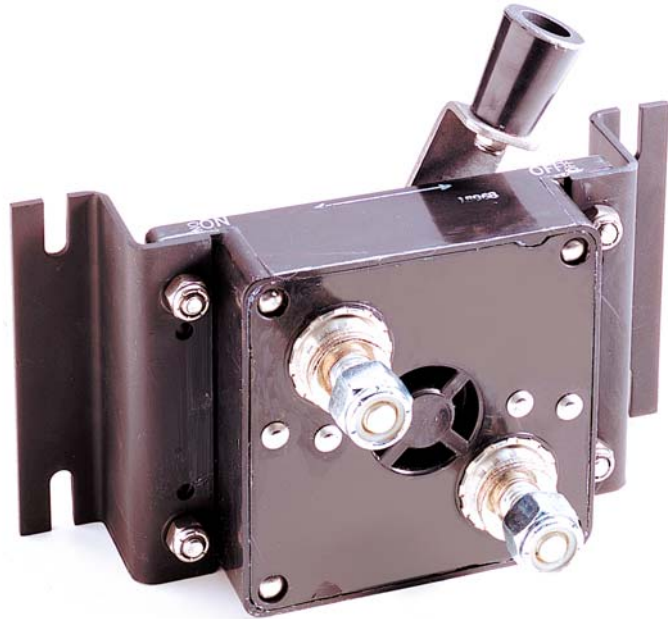

### Specifications

**Applications:** A non-fused current interrupt disconnect designed for opening the circuit between a battery and the complete electrical load of a battery-powered system.

**Rating:** 400A continuous, 50Vac/Vdc. Vehicle cranking and max. surge currents to 2000A (based on 20% duty cycle with ON times of 5 seconds max.).

**Temperature Rating:** -40°F (-40°C) to 150°F (65°C).

**Termination:** 1/2-13 Copper alloy stud.

**Torque Rating:** 420 in-lbs (47.5N•m) max.

**Mounting Torque Rating:** With mounting brackets: 48 in-lbs (5.4N•m) max; without mounting brackets: 10 in-lbs (1.1N•m) max.

### Options

**Handles:** Three handle styles available.

**Other:** Lubricant-filled body with silicone sealant.

### Part Numbering System

Series	Handle Option	Bracket Option	Lubricant w/Sealant
15250	□	□	LR
	1	B - Bracket	(Grease Filled)
	2		
	3		

**Dimensions - mm(in) (15250-1b Shown)** (Dims. shown are for reference only. Consult factory for latest prints)

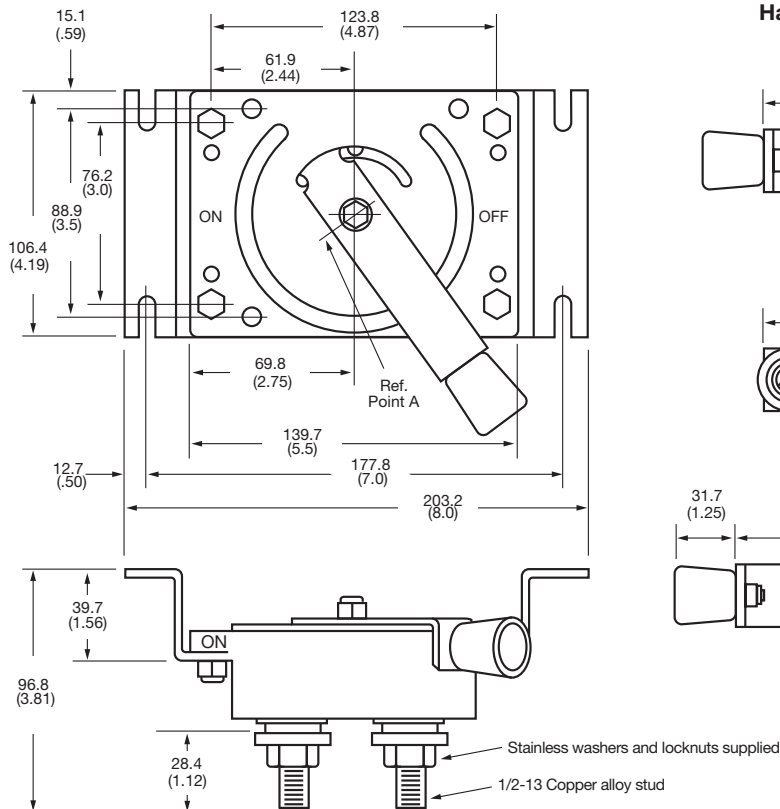

### Handle Variations

