

SYMBOL DEFINITION	
A DIMENSION WITHOUT AN INSPECTION REPORT SYMBOL  DOES NOT REQUIRE INSPECTION. IT MAY BE CONTROLLED ON THE INDIVIDUAL COMPONENT DRAWING.	TOTAL NO OF INSPECTIONS REQUIRED
	16
	LAST NO. USED
	12

MISSING SYMBOLS					DWG STATUS			REVISION HISTORY			AUTH		DR		APVD	
NO MISSING SYMBOL NUMBER	DATE	STG	REV	N/P	CHG	ZONE	REVISION HISTORY			AUTH	DR	APVD1	APVD2			
	05FE09	R	C2	-	-		CLEARED REV COL., REDRAWN TO PD AND UPDATED MAT'L CALLOUT			407256	ESC	SCR	PTG			

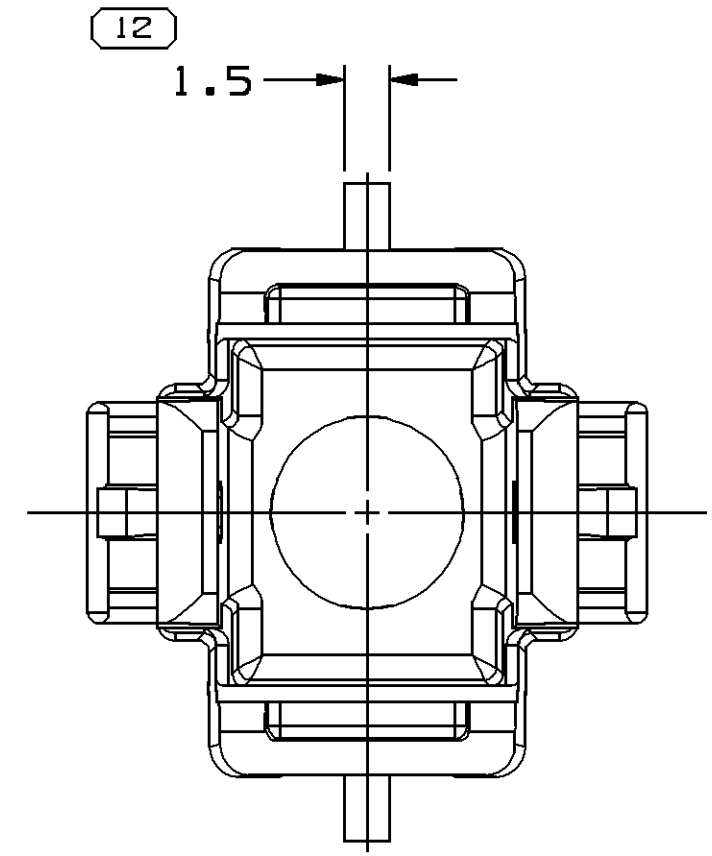
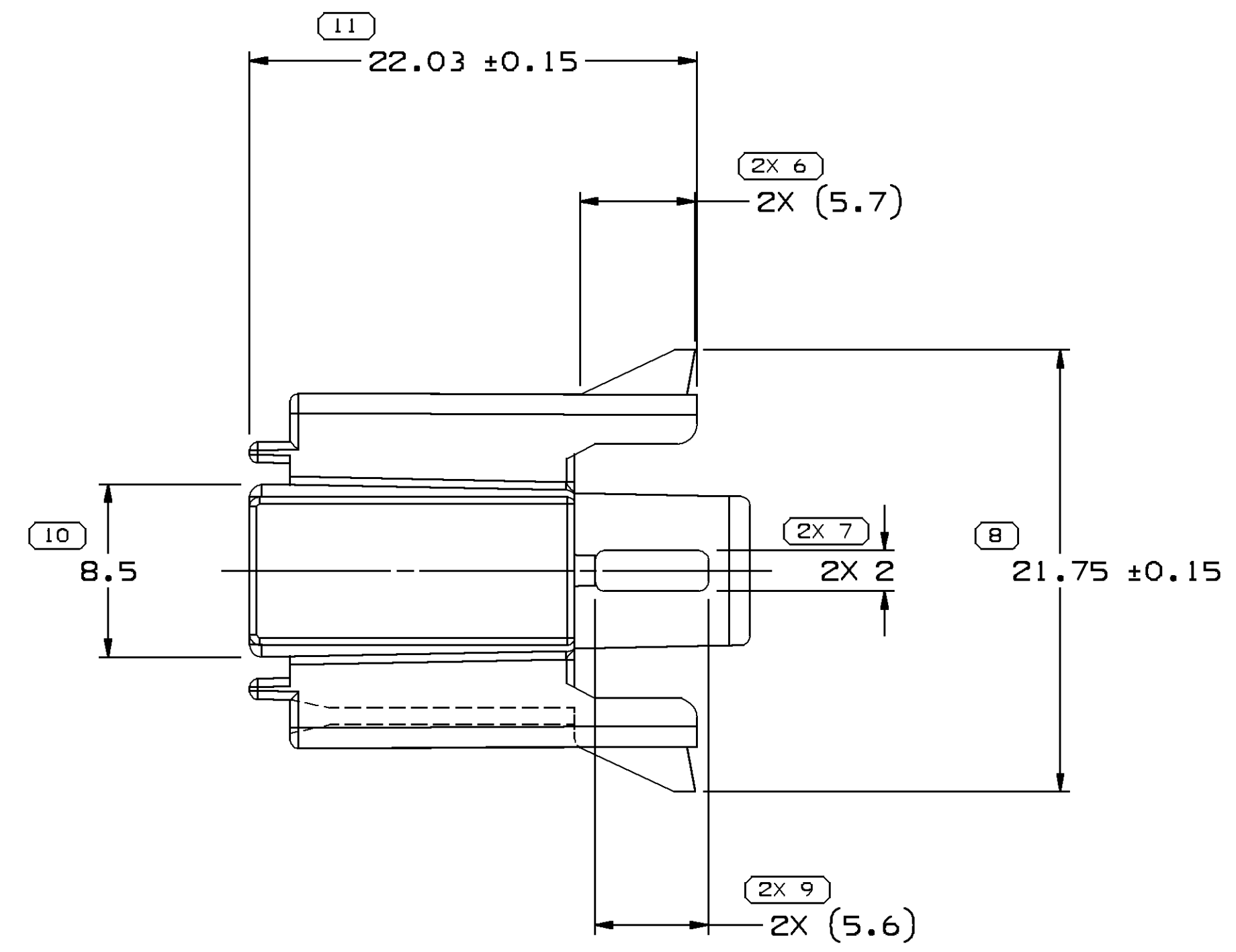
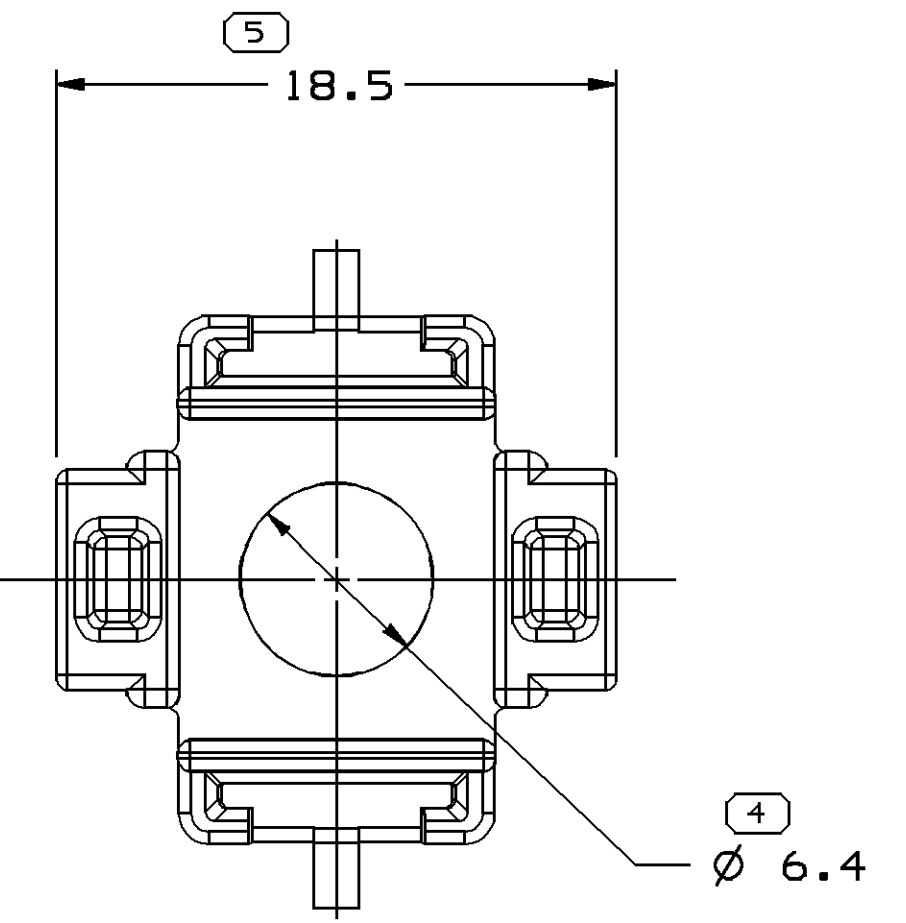
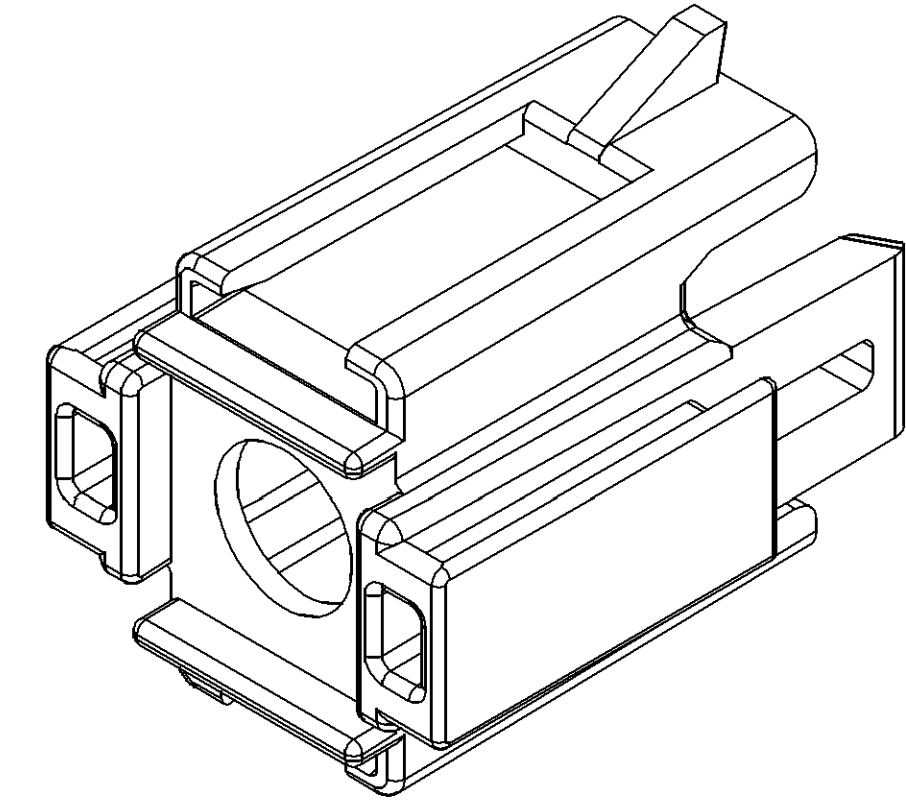
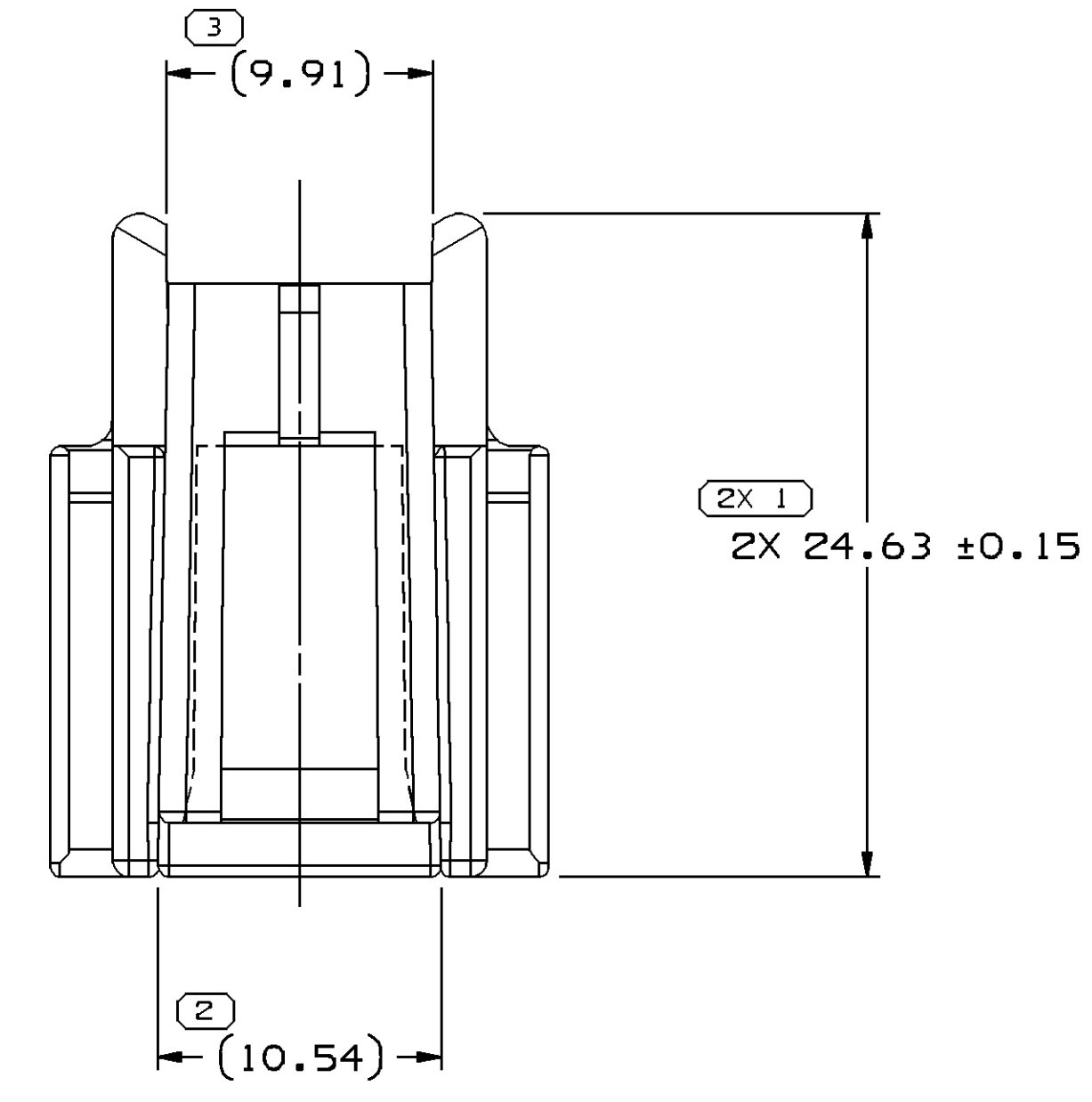

NOTES

- UNLESS OTHERWISE SPECIFIED AND/OR INDICATED:  
DIMENSIONS ARE TO FACE OF VIEW SHOWN AND AUTOMATICALLY ROUNDED BY COMPUTER FOR INSPECTION (SEE MATH MODEL FOR PRECISE DIMENSIONS). FOR ALL OTHER DIMENSIONS NOT SHOWN BUT REQUIRED FOR TOOL BUILD, SEE MATH MODEL FOR PRECISE TOOL PATH DATA.
- MATERIAL RECYCLING CODE PER ISO 11469. (1.5)X(0.1) CHARACTERS AS SHOWN TO BE LOCATED ON ANY EXTERIOR SURFACE. OPTIONAL CONSTRUCTION TO BE NO MATERIAL RECYCLING CODE.
- THIS PRODUCT IS NOT CATEGORIZED AS AN APPEARANCE ITEM, MINOR IMPERFECTIONS INCLUDING, BUT NOT LIMITED TO, FLOW MARKS, COLOR BLEMISHES, GATE VESTIGE, AND SOFT FLASH THAT DO NOT AFFECT THE FIT, FORM, OR FUNCTION OF THE PART ARE PERMISSIBLE PER NAP 4.10-18.
- (1.5)X(0.1) DELPHI CORPORATE BRAND TO BE LOCATED ON ANY EXTERIOR SURFACE, PREFERABLY VISIBLE AT FINAL ASSEMBLY. OPTIONAL CONSTRUCTION FOR EXISTING TOOLING MAY BE "PED" OR NO LOGO.

DIMENSIONAL RANGE (MM)		CHART ET	
FROM	TO	> 0	> 300
> 0	> 20	> 30	> 100
> 20	> 30	> 70	> 150
> 30	> 70	> 100	> 200
> 70	> 100	> 150	> 250
> 100	> 150	> 200	> 300
> 150	> 200	> 250	> 400

TOLERANCE UNLESS OTHERWISE SPECIFIED  
 ±0.15 | ±0.2 | ±0.3 | ±0.4 | ±0.5 | ±0.6 | ±0.8 | ±1 | ±1.2  
 ANGULAR TOLERANCE ±2°

DWG TYPE PART DRAWING	
STYLE	
VOLUME (C/P) 1.985	DISTR CODE D
UNLESS OTHERWISE SPECIFIED THIS DOCUMENT IS IN ACCORDANCE WITH ASME Y14.5M-1994 AS AMENDED BY THE GM GLOBAL DIMENSIONING AND TOLERANCING ADDENDUM-2001. SEPARATE PATTERNS OF FEATURES MAY BE GAGED SEPARATELY REGARDLESS OF DATUM REFERENCES.	
ALL DIMENSIONS ARE IN MILLIMETERS	
REFERENCE	
THIRD ANGLE PROJECTION	DO NOT SCALE USE MATH DATA

**DELPHI**  
 DELPHI PACKARD ELECTRICAL/ELECTRONIC ARCHITECTURE  
 WARREN, OH

DR	DATE
APVD1 H. CASTRILLON	26MY97
APVD2 FCO. KOPCA	26MY97
APVD3 D. MC EOWEN	04JN97
APVD4	
APVD5	

SUBSTANCES OF CONCERN AND RECYCLED CONTENT PER DELPHI 10945001

MATERIAL  
POLYAMIDE COMPOUND BLACK

DRAWING NAME  
MOUN ATTCH CLIP SPECIAL

DRAWING NUMBER  
15317948

SIZE	SCALE	FRAME NO	SHEET NO	STG	REV	N/P
A1	4:1	1 OF 1	1 OF 1	R	C2	-