

SYMBOL DEFINITION			MISSING NUMBERS		
A DIMENSION WITHOUT AN INSPECTION REPORT SYMBOL  DOES NOT REQUIRE INSPECTION. IT MAY BE CONTROLLED ON AN INDIVIDUAL COMPONENT DRAWING.	TOTAL NO. OF SYMBOLS ON DRAWING	11			
	LAST NO. USED	15			

DWG STATUS					ZONE	REVISION HISTORY			AUTH	DR	APVD1	APVD2
DATE	STG	REV	N/P	CHG								
15MY03	R	A1	-	-		CLEARED REV COLUMN & 6.38 +0.6/-0.15 WAS 6.38 (2 PLCS)			241223	EOV	EOV	FR

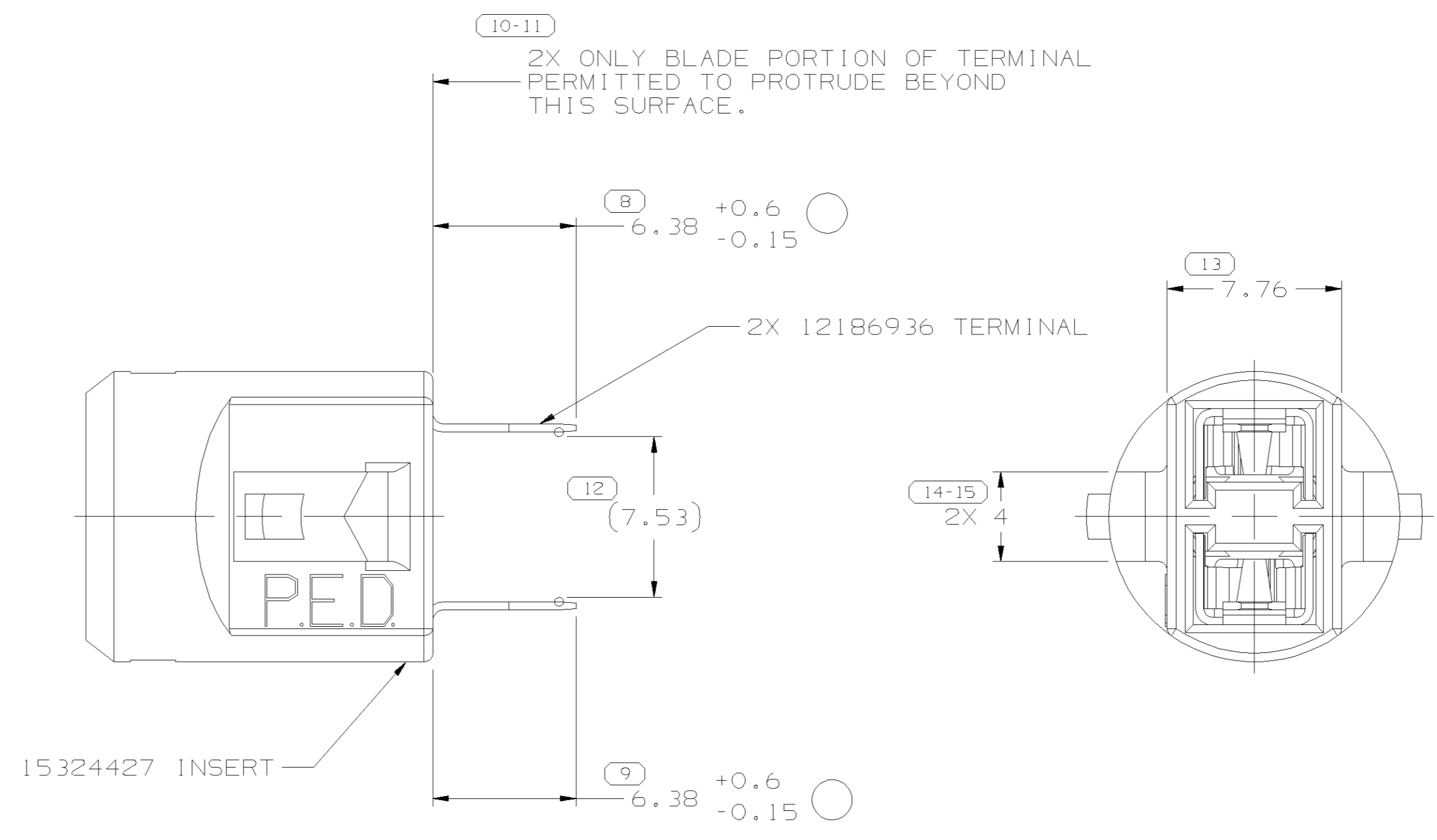
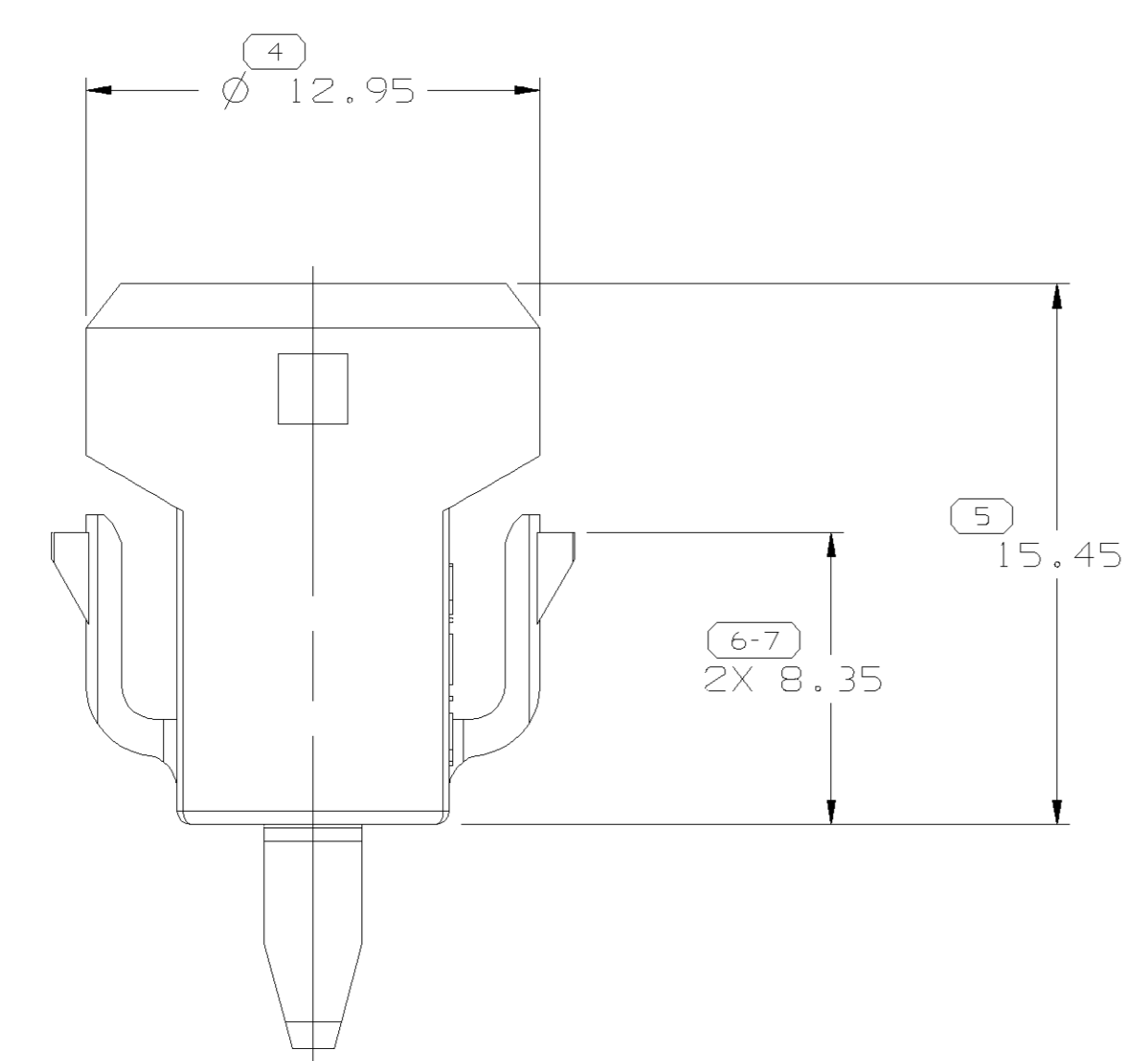
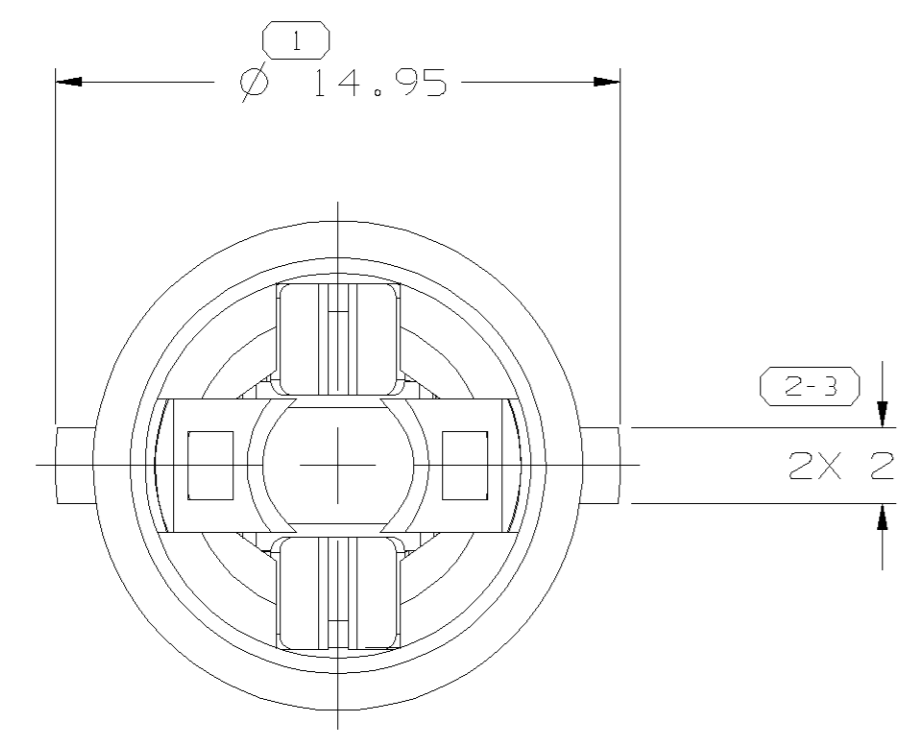
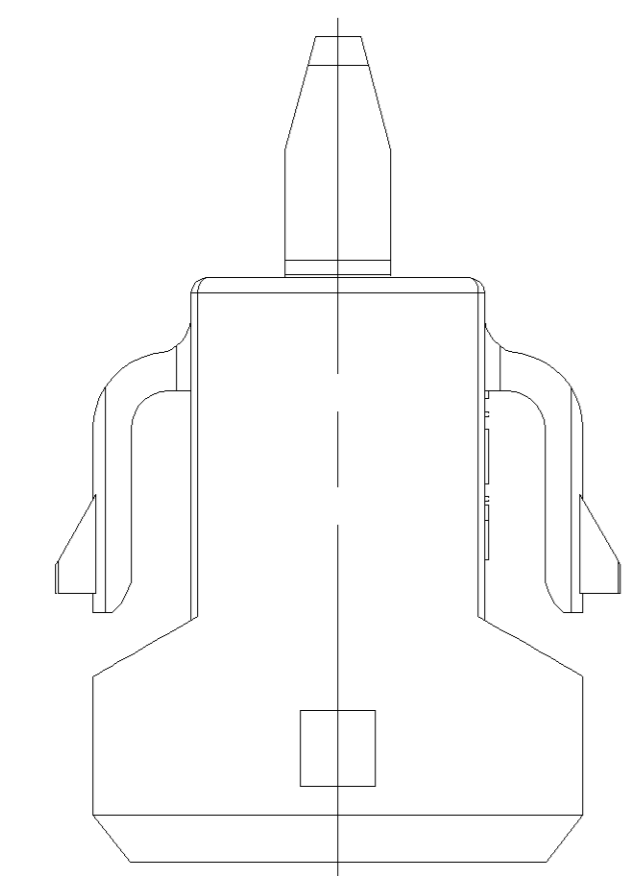

NOTES

- UNLESS OTHERWISE SPECIFIED AND/OR INDICATED: DIMENSIONS ARE TO FACE OF VIEW SHOWN AND AUTOMATICALLY ROUNDED BY COMPUTER FOR INSPECTION. (SEE MATH MODEL FOR PRECISE DIMENSIONS.) FOR ALL OTHER DIMENSIONS NOT SHOWN BUT REQUIRED FOR TOOL BUILD, SEE MATH MODEL FOR PRECISE TOOL PATH DATA.
- MATING COMPONENTS OR EQUIVALENT:
LAMP SOCKET 12146418
BULB 09421330
- ASSEMBLIES TO BE PACKED SUCH THAT BLADES WILL NOT BE BENT OR OTHERWISE DAMAGED IN HANDLING.

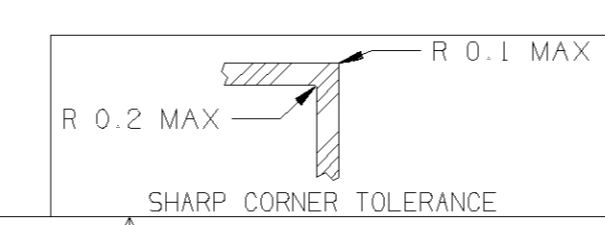
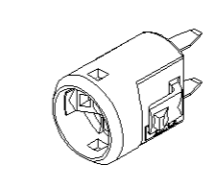

DIMENSIONAL RANGE (MM)		CHART E1	
FROM	TO	TOLERANCE UNLESS OTHERWISE SPECIFIED	ANGULAR TOLERANCE ±2°
>0	>20	±0.15	±1
>20	>30	±0.2	±1.2
>30	>70	±0.3	
>70	>100	±0.4	
>100	>150	±0.5	
>150	>200	±0.6	
>200	>250	±0.8	
>250	>300	±1	
>300	>400	±1.2	

DWG TYPE PART DRAWING	
STYLE	
VOLUME (CM³) 6900	DISTR CODE D
ROUTING UNLESS OTHERWISE SPECIFIED	
THIS DOCUMENT IS IN ACCORDANCE WITH ASME Y14.5M-1994 AS AMENDED BY THE GM GLOBAL DIMENSIONING AND TOLERANCING ADDENDUM - 1997. ALL GEOMETRIC TOLERANCES AND RELATED DATUMS APPLY FIRST. RULE #1 PERFECT FORM AT MMC DOES NOT APPLY WHEN RELATIONSHIP BETWEEN FEATURES IS ESTABLISHED BY ORIENTATION OR LOCATION TOLERANCES. SEPARATE POSITION CALLOUTS MAY BE GAGED SEPARATELY, REGARDLESS OF DATUM REFERENCE. ALL DIMENSIONS ARE IN MILLIMETERS.	
THIRD ANGLE PROJECTION	
DO NOT SCALE	
USE MATH DATA	

DELPHI
DELPHI PACKARD ELECTRIC SYSTEMS
WARREN, OH

DR	DATE
APVD1 E. RODRIGUEZ	050C98
APVD2 R. CHACON	050C98
APVD3	
APVD4	
APVD5	

MATERIAL
SUBSTANCES OF CONCERN AND RECYCLED CONTENT PER DELPHI 10949001

DRAWING NAME
ASM INSERT LP SOC WGE BSE

DRAWING NUMBER
15324428

SIZE A1	SCALE 5:1	FRAME NO 1 OF 1	SHEET NO 1 OF 1	STG R	REV A1	N/P -
------------	--------------	--------------------	--------------------	----------	-----------	----------