

SYMBOL DEFINITION		MISSING SYMBOLS	
A DIMENSION WITHOUT AN INSPECTION REPORT SYMBOL () DOES NOT REQUIRE INSPECTION. IT MAY BE CONTROLLED ON THE INDIVIDUAL COMPONENT DRAWING.	TOTAL NO OF INSPECTIONS REQUIRED	NO MISSING SYMBOL NUMBER	7
	LAST NO. USED		7

DWG STATUS					ZONE	REVISION HISTORY			AUTH	DR	APVD1	APVD2
DATE	STG	REV	N/P	CHG								
18AU03	R	C1	-	-		REDRAWN TO PD			243589	AMG	AMG	AJC
15FE05	R	C2	-	-		REVISED MATERIAL DESCRIPTION AND ADDED PROCESSING NOTES			264753	JPB	JVM	WLM

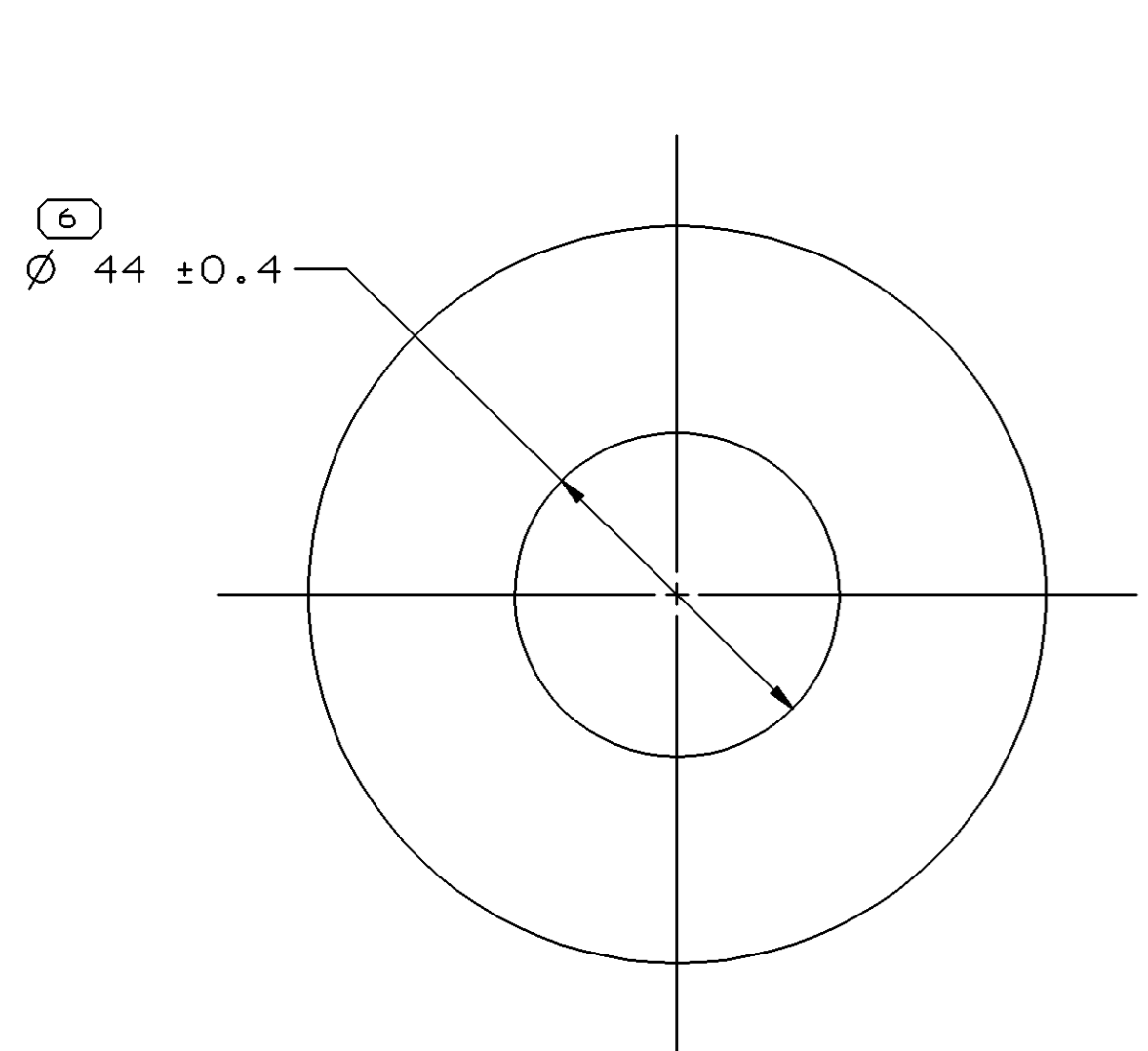

MOUNTING HOLE DETAIL
INSPECTION SYMBOLS SHOWN IN THESE
VIEWS ARE FOR REFERENCE ONLY

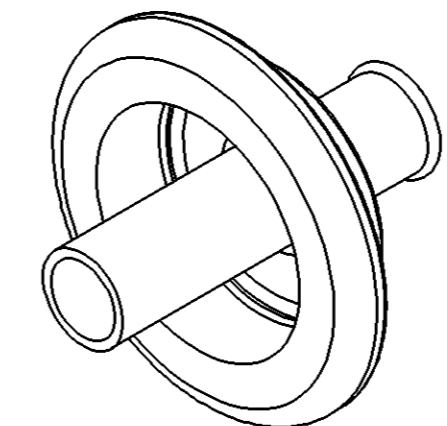
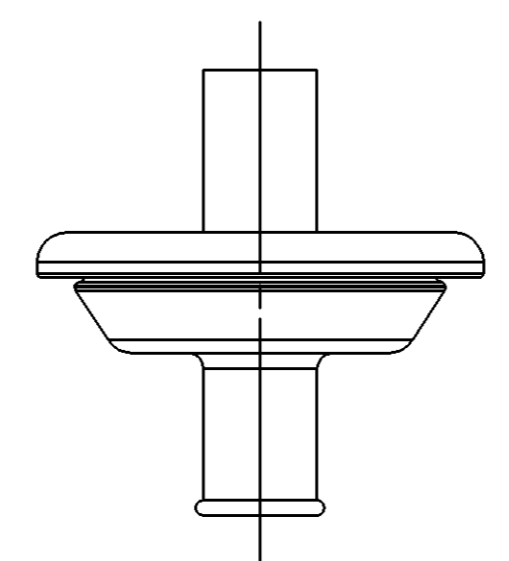
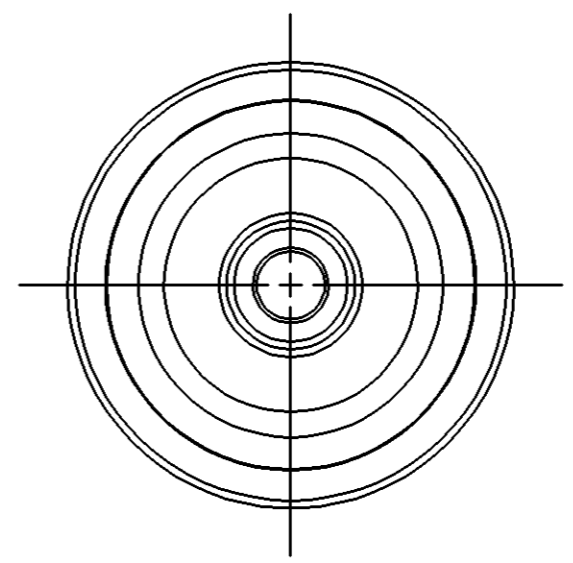
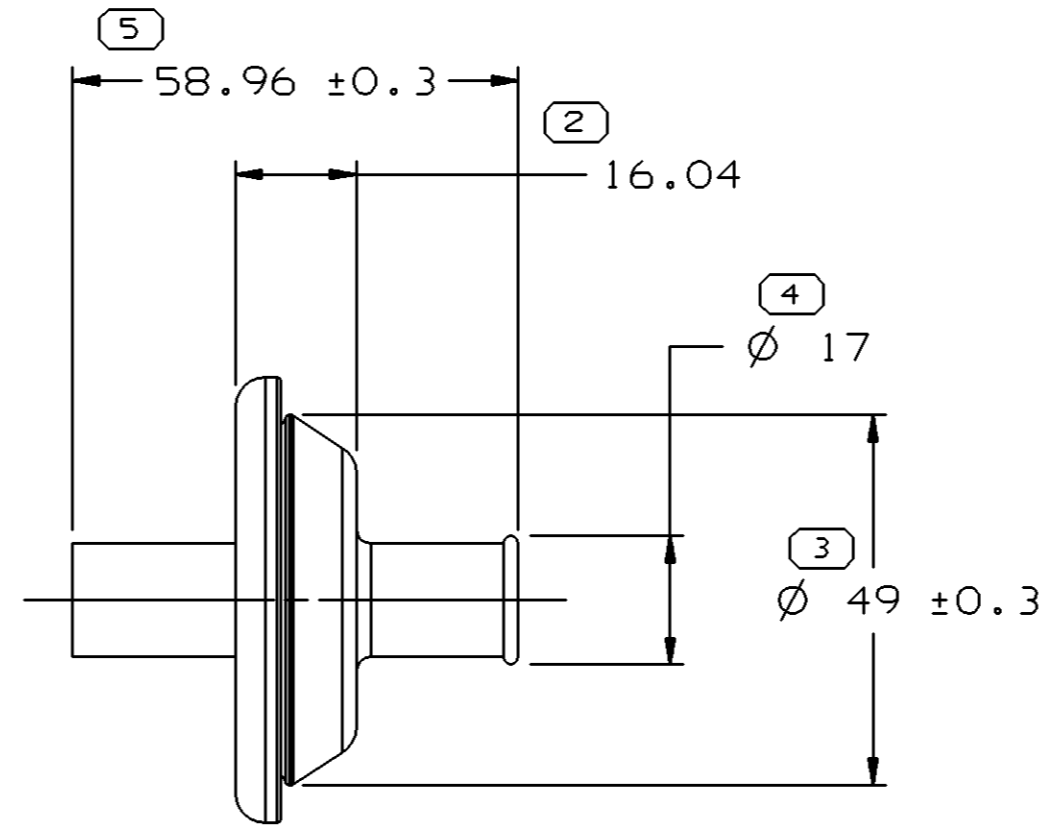
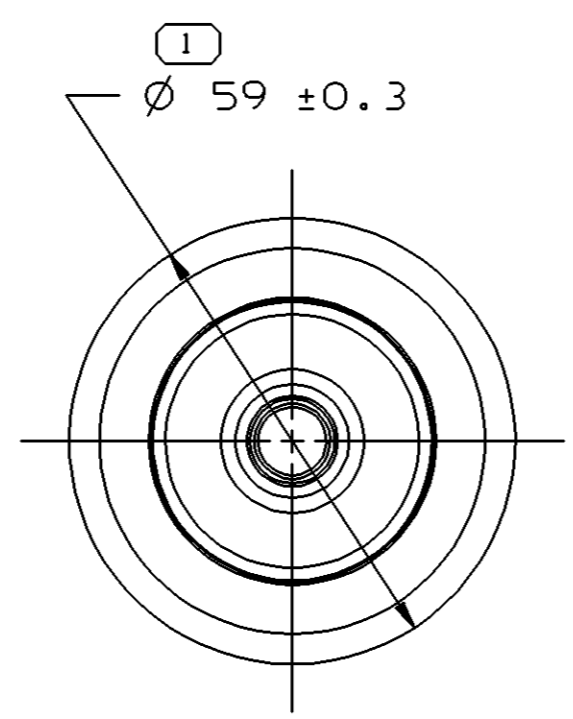
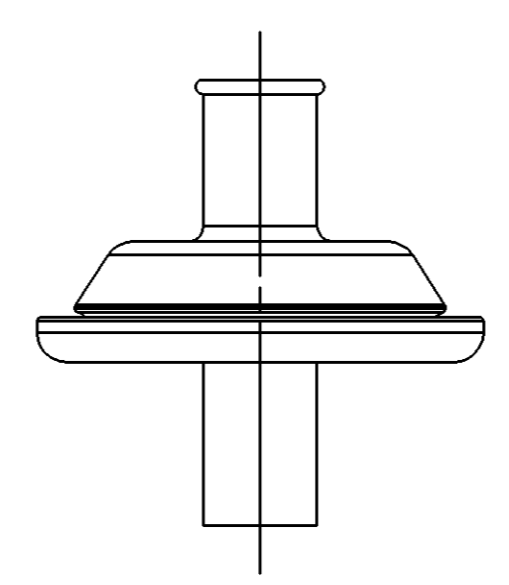
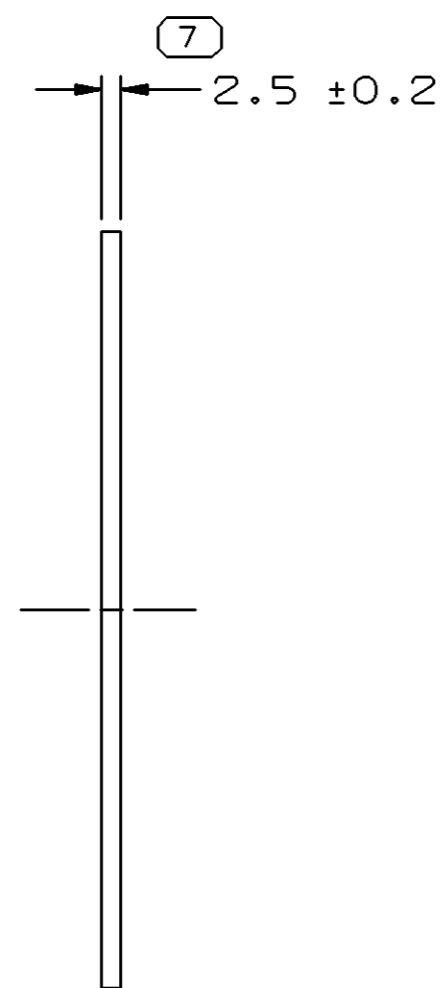

NOTES

- UNLESS OTHERWISE SPECIFIED AND/OR INDICATED:
DIMENSIONS ARE TO FACE OF VIEW SHOWN AND AUTOMATICALLY ROUNDED BY COMPUTER FOR INSPECTION (SEE MATH MODEL FOR PRECISE DIMENSIONS). FOR ALL OTHER DIMENSIONS NOT SHOWN BUT REQUIRED FOR TOOL BUILD, SEE MATH MODEL FOR PRECISE TOOL PATH DATA.
- THIS PART IS NOT CONTROLLED FOR AUTOMATIC FEEDING.
- PART IS SYMMETRICAL ABOUT CENTERLINES EXCEPT AS NOTED.
- SEALING SURFACES MUST BE FREE OF SINKS, NFO'S, VOIDS, KNIT/FLOW LINES, ETC.
- THIS GROMMET TO BE USED WITH HARNESS BUNDLE SMOOTH TAPE WRAPPED USING 5 MIL TAPE HAVING NO SLITS ON EDGES.

PROCESSING NOTES:

THE FOLLOWING NUMBER IS TO BE PUT ON THE PRODUCT DRAWING AS THE MAXIMUM ALLOWABLE STRETCH DIMENSION: 37MM AS MEASURED IN THE FOLLOWING FASHION:

MAXIMUM ALLOWABLE DIMENSION OF STRETCHED GROMMET NECK WHEN USING A 4 BILL SPREADER

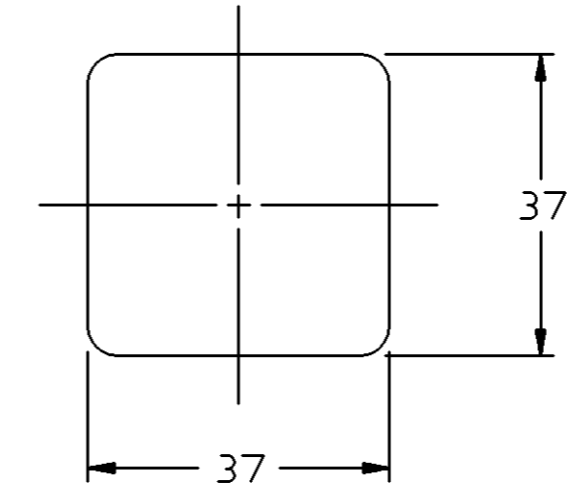

DIMENSIONAL RANGE (MM)				CHART	C
FROM	> 0	> 25	> 60	> 80	
TO	25	60	80	> 80	
TOLERANCE UNLESS OTHERWISE SPECIFIED					
	± 0.3	± 0.5	± 0.6	± 0.75	
ANGULAR TOLERANCE $\pm 2^\circ$					

DWG TYPE		PART DRAWING	
STYLE			
VOLUME (CM ³)	17.752	DISTR CODE	D
UNLESS OTHERWISE SPECIFIED			
THIS DOCUMENT IS IN ACCORDANCE WITH ASME Y14.5M-1994 AS AMENDED BY THE GM GLOBAL DIMENSIONING AND TOLERANCING ADDENDUM - 1997. ALL GEOMETRIC TOLERANCES AND RELATED DATUMS APPLY RFS. RULE #1 PERFECT FORM AT MMC DOES NOT APPLY WHEN RELATIONSHIP BETWEEN FEATURES IS ESTABLISHED BY ORIENTATION OR LOCATION TOLERANCES. SEPARATE POSITION CALLOUTS MAY BE GAGED SEPARATELY, REGARDLESS OF DATUM REFERENCE. ALL DIMENSIONS ARE IN MILLIMETERS			
REFERENCE			
THIRD ANGLE PROJECTION	DO NOT SCALE	UNIGRAPHICS	
USE MATH DATA			

DELPHI			
DELPHI PACKARD ELECTRIC SYSTEMS WARREN, OH			
DR			DATE
APVD1	ANDRES MENDEZ	05AU03	
APVD2	ANDRES MENDEZ	05AU03	
APVD3	ANTHONY CORSO	07AU03	
APVD4			
APVD5			
SUBSTANCES OF CONCERN AND RECYCLED CONTENT PER DELPHI 10949001			
MATERIAL M4432002			
DRAWING NAME GROM TAPE ON			
DRAWING NUMBER 15326369			
SIZE	SCALE	FRAME NO	SHEET NO
A1	1:1	1 OF 1	1 OF 1
STG	REV	N/P	
R	C2	-	