

SYMBOL DEFINITION		MISSING NUMBERS	
THE NUMBER INSIDE THE SYMBOL  CORRESPONDS TO THE NUMBER ON THE INSPECTION REPORT FOR THIS DRAWING/PART NUMBER	TOTAL NO. OF SYMBOLS ON DRAWING	12	
	LAST NO. USED	19	

DWG STATUS					ZONE	REVISION HISTORY			AUTH	DR	APVD1	APVD2
DATE	STG	REV	N/P	CHG		Cleared revision column, changed note 2			231461	LMB	KMB	TV
100C02	R	02	-	-								

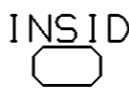
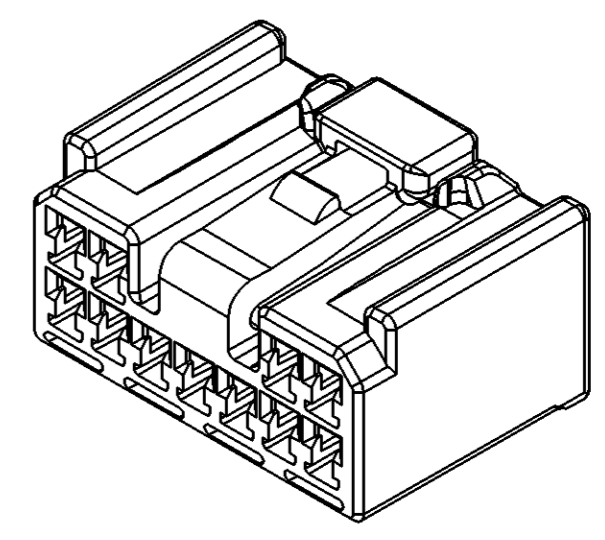
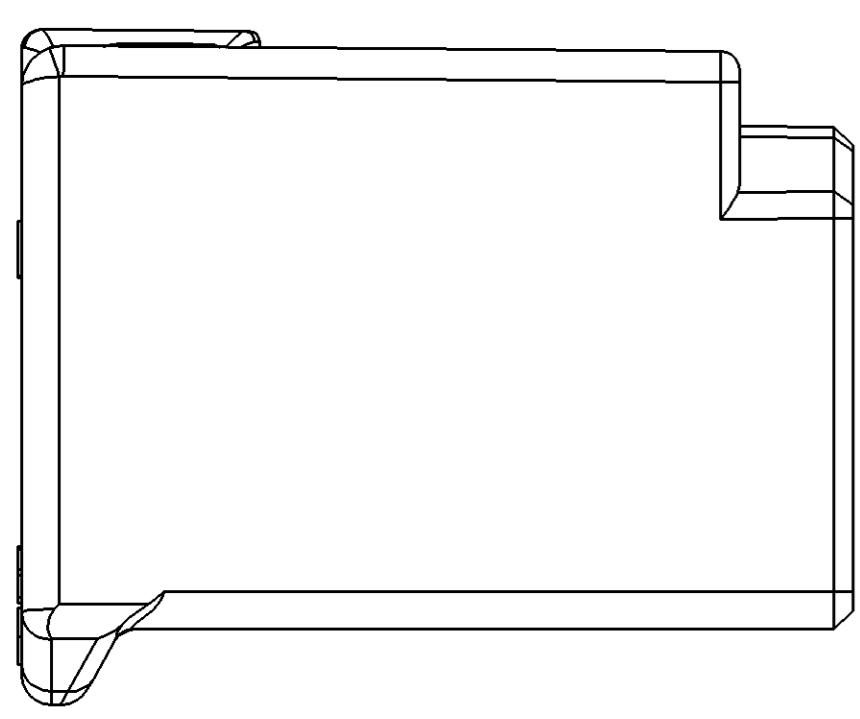
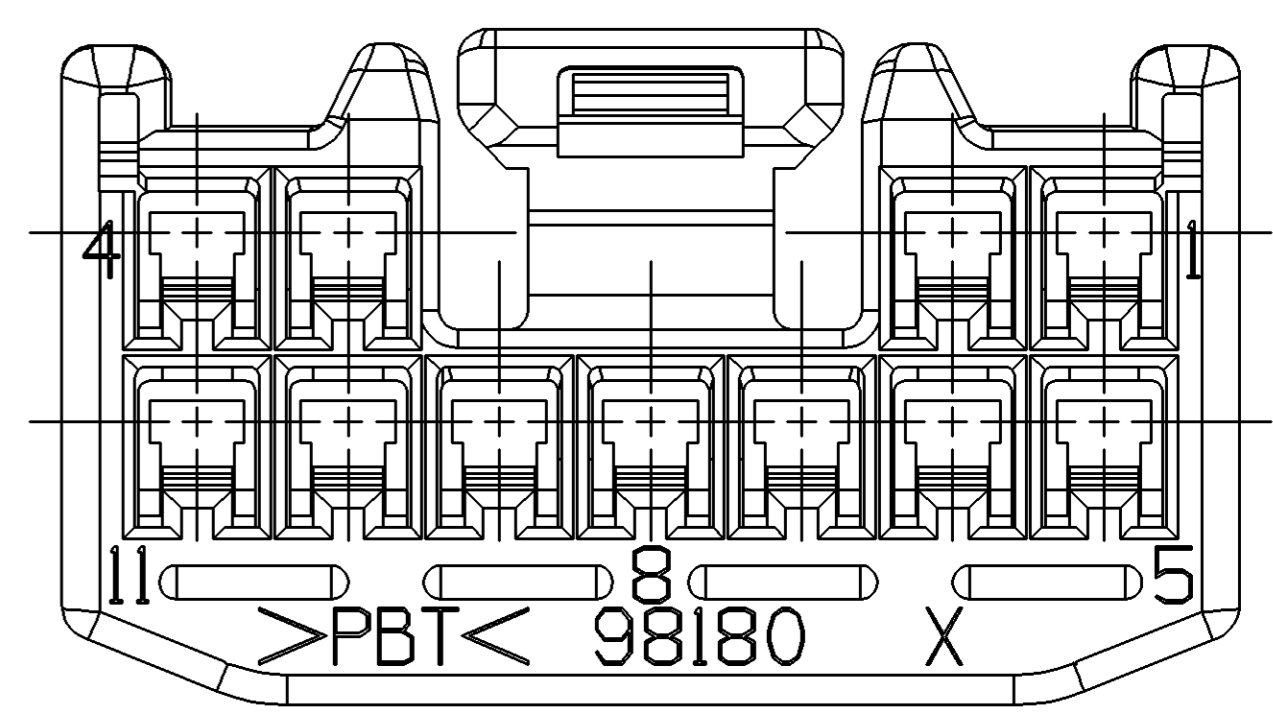
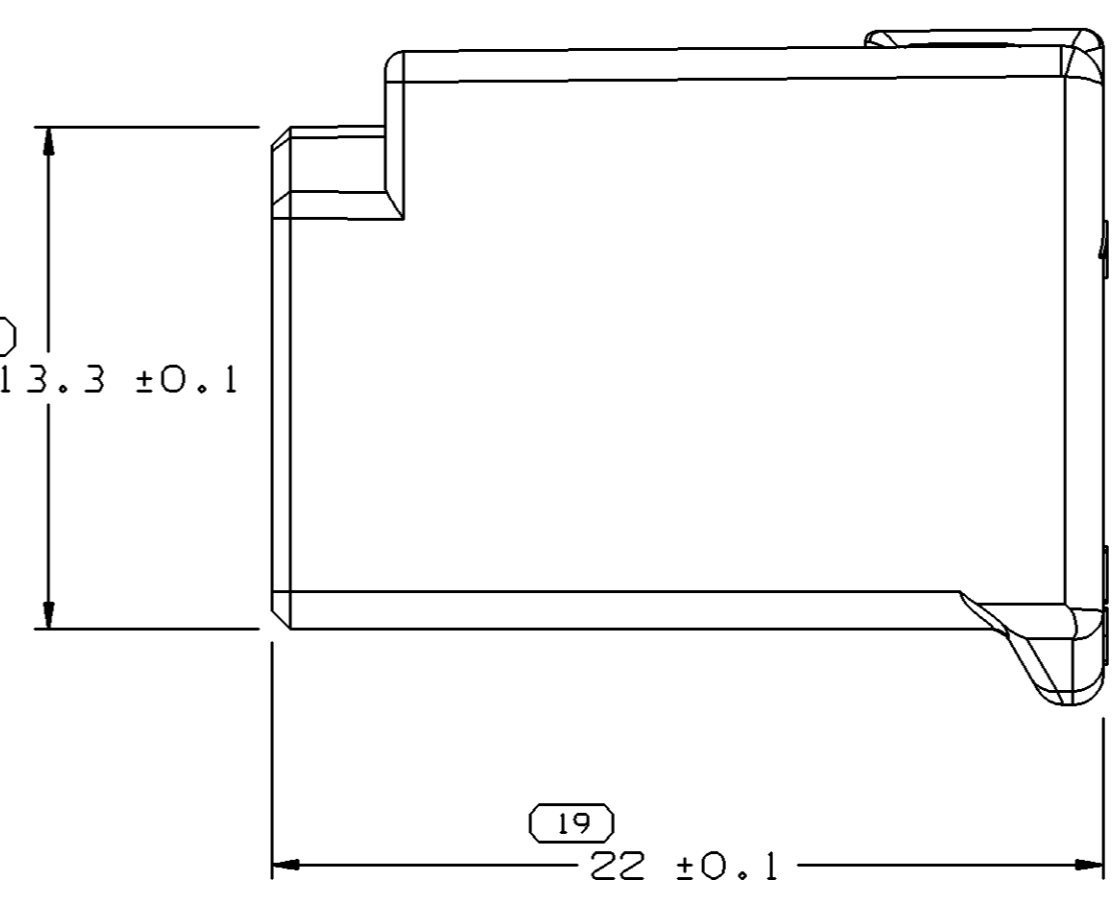
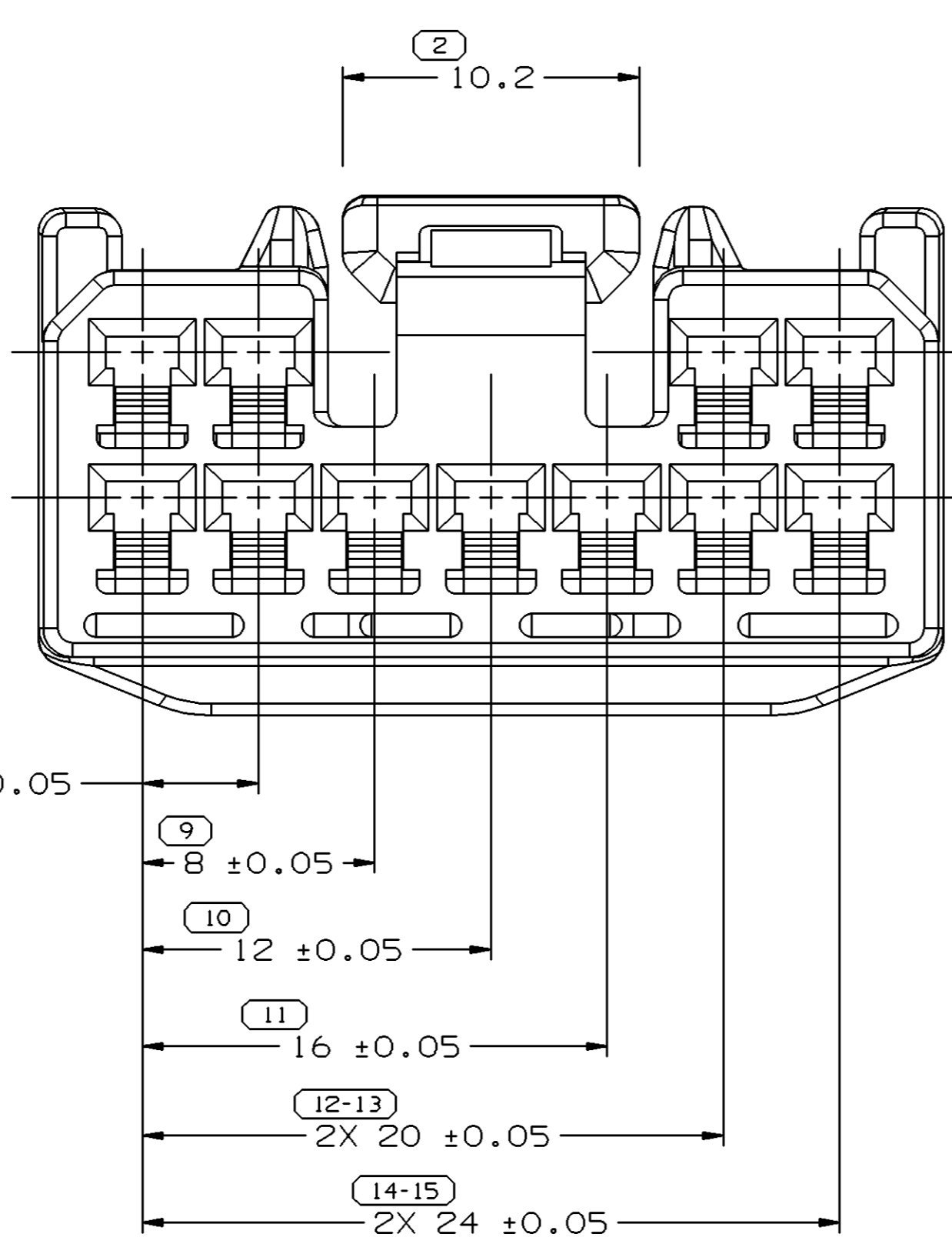
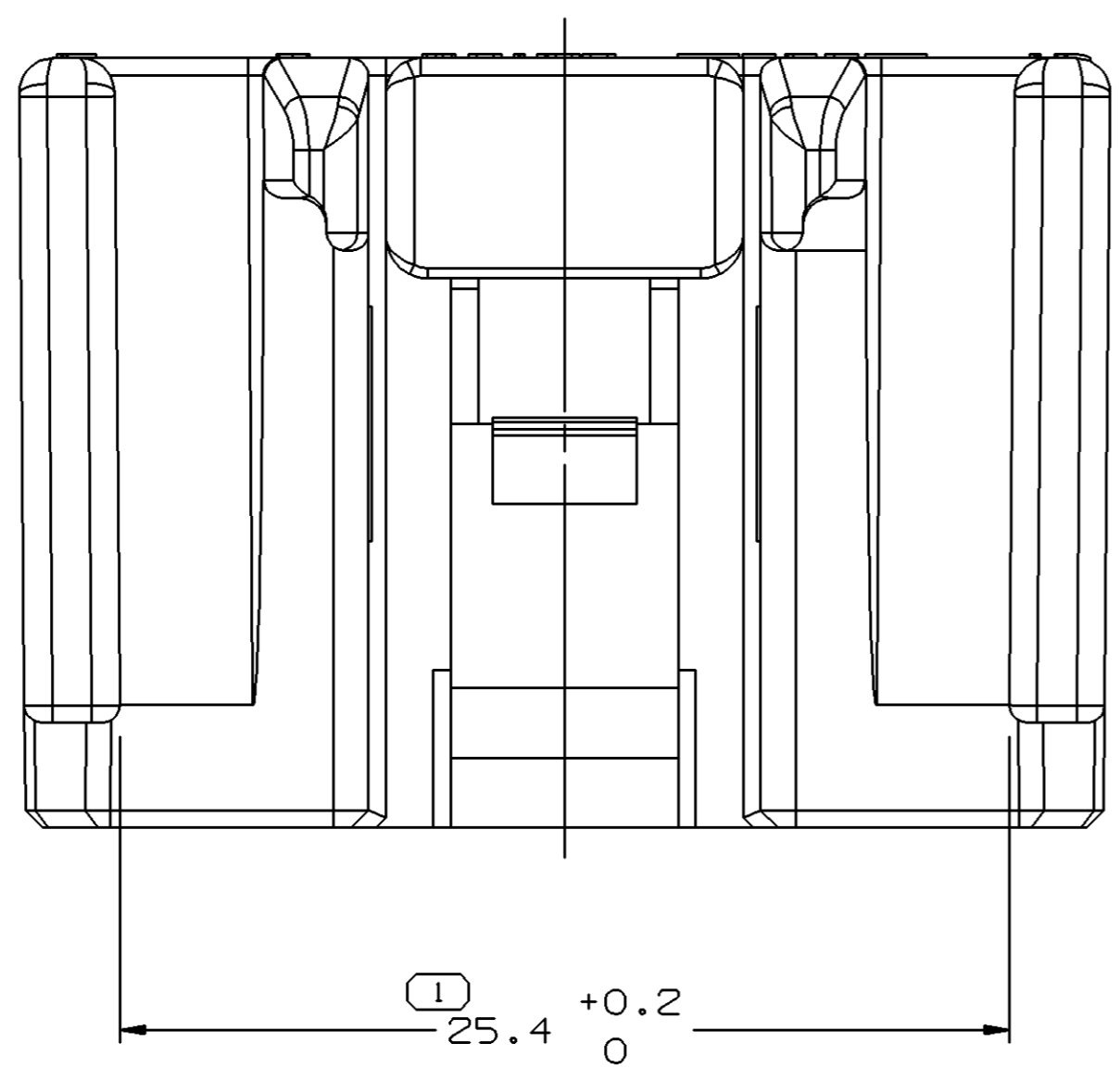

- NOTES:
- UNLESS OTHERWISE SPECIFIED AND/OR INDICATED: DIMENSIONS ARE TO FACE OF VIEW SHOWN AND AUTOMATICALLY ROUNDED BY COMPUTER FOR INSPECTION. (SEE MATH MODEL FOR PRECISE DIMENSION) FOR ALL OTHER DIMENSIONS NOT SHOWN BUT REQUIRED FOR TOOL BUILD, SEE MATH MODEL FOR PRECISE TOOL PATH DATA.
 - MATING COMPONENTS: CONNECTOR 15318014 OR EQUIVALENT TERMINAL SECONDARY LOCK - 15318015 OR EQUIVALENT CAVITIES TO ACCEPT 09011 15305111 OR EQUIVALENT
 - PART SHOULD CONFORM TO TSC 1000G/TSC 1225G.

PART NO	REV	STATUS	MATERIAL SPECIFICATION AND COLOR	VOLUME
15326440	B1		R0100109 PBT-GRA	4.430
15326439	B1		PM002191-014 PBT ORN LT	4.430
15318013	B1		R0100185 PBT-NAT	4.430

DIMENSIONAL RANGE (MM)		CHART	F
FROM	0	> 10	
TO	10	> 50	
TOLERANCE UNLESS OTHERWISE SPECIFIED			
±0.15		±0.2	
ANGULAR TOLERANCE		±1°	

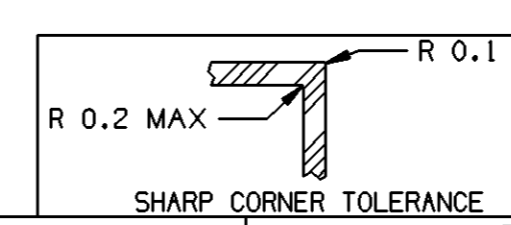

DWG TYPE		PART DRAWING	
STYLE		DISTR CODE	D
VOLUME (CM ³)	SEE CHART		
ROUTING	6900,6901		
UNLESS OTHERWISE SPECIFIED			
THIS DOCUMENT IS IN ACCORDANCE WITH ASME Y14.5M-1994 AS AMENDED BY THE GM GLOBAL DIMENSIONING AND TOLERANCING ADDENDUM - 1997. ALL GEOMETRIC TOLERANCES AND RELATED DATUMS APPLY RFS. RULE #1 PERFECT FORM AT MMC DOES NOT APPLY WHEN RELATIONSHIP BETWEEN FEATURES IS ESTABLISHED BY ORIENTATION OR LOCATION TOLERANCES. SEPARATE POSITION CALLOUTS MAY BE GAGED SEPARATELY, REGARDLESS OF DATUM REFERENCE. ALL DIMENSIONS ARE IN MILLIMETERS			
THIRD ANGLE PROJECTION	DO NOT SCALE	USE MATH DATA	

DELPHI
DELPHI PACKARD ELECTRIC SYSTEMS
WARREN, OH

DR	DATE
APVD1 M. PANNU	24JN98
APVD2 K. CARLTON	31AU98
APVD3 G. CHEN	31AU98
APVD4	
APVD5	

UNLESS OTHERWISE SPECIFIED
SUBSTANCES OF CONCERN AND RECYCLED CONTENT PER DELPHI 10949001

MATERIAL SEE CHART

DRAWING NAME TAXI CONN 11F 090 11

DRAWING NUMBER 15354921

SIZE	SCALE	FRAME NO	SHEET NO	STG	REV	N/P
A1	5:1	1 OF 1	1 OF 1	R	02	-