

SYMBOL DEFINITION		MISSING NUMBERS	
THE NUMBER INSIDE THE SYMBOL  CORRESPONDS TO THE NUMBER ON THE INSPECTION REPORT FOR THIS DRAWING/PART NUMBER	TOTAL NO. OF SYMBOLS ON DRAWING	13	
	LAST NO. USED	24	

DWG STATUS				ZONE	REVISION HISTORY	AUTH	DR	CK	APVD
DATE	STG	REV	CHG N/P						
09AU00	R	001	-		WAS PE076314 AND RELEASED	000005	MRL	MJC	SRM
16N000	R	002	-		REVISED GRAPHICS	204273	MRL	KLC	SRM
22MY01	R	003	-		UPDATED HD CONN 15374208 TO REV 003	209229	EES	JLJ	DLJ
11JA02	R	003	-	AA	REVISED TOL 13 PLCS; CODE WAS 6900	219316	TMR	TLP	JDS

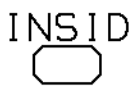
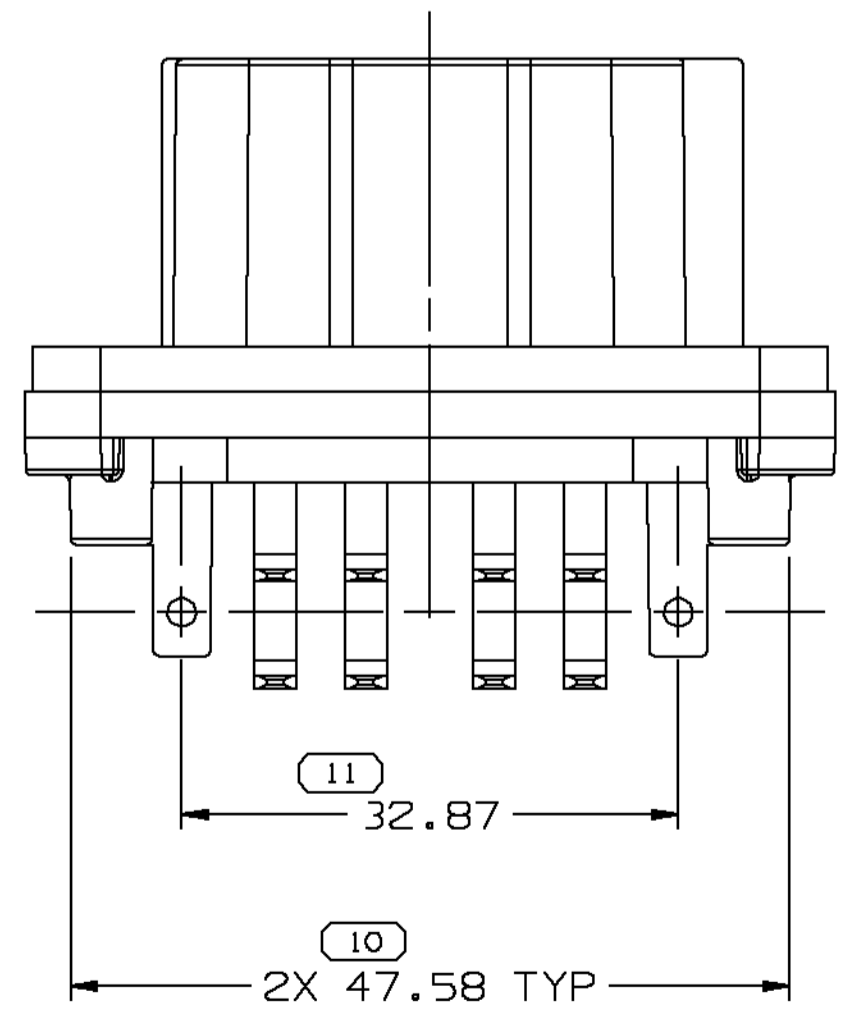
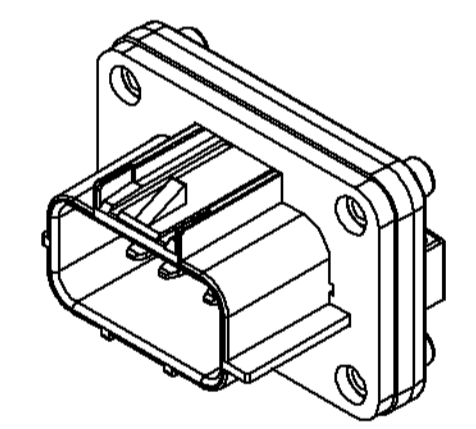
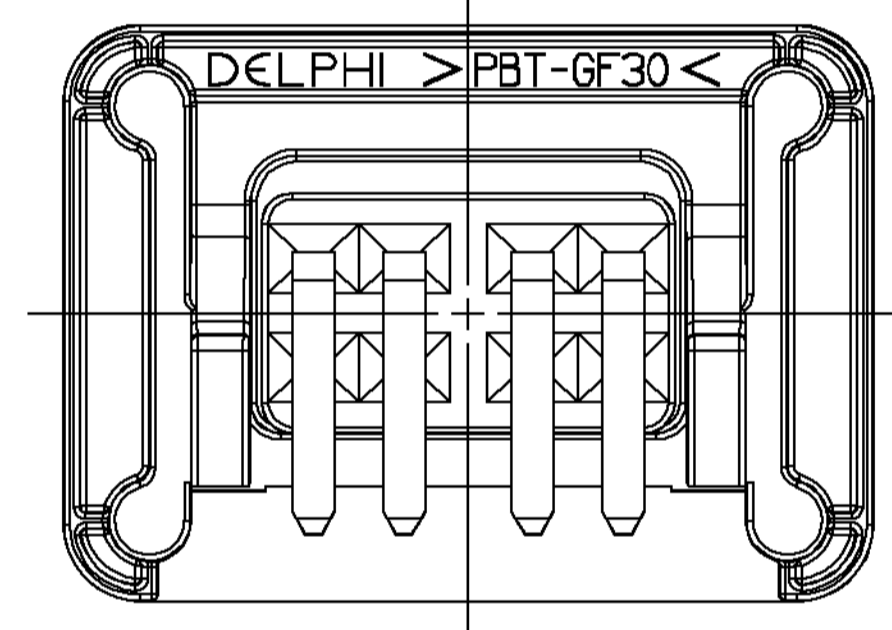
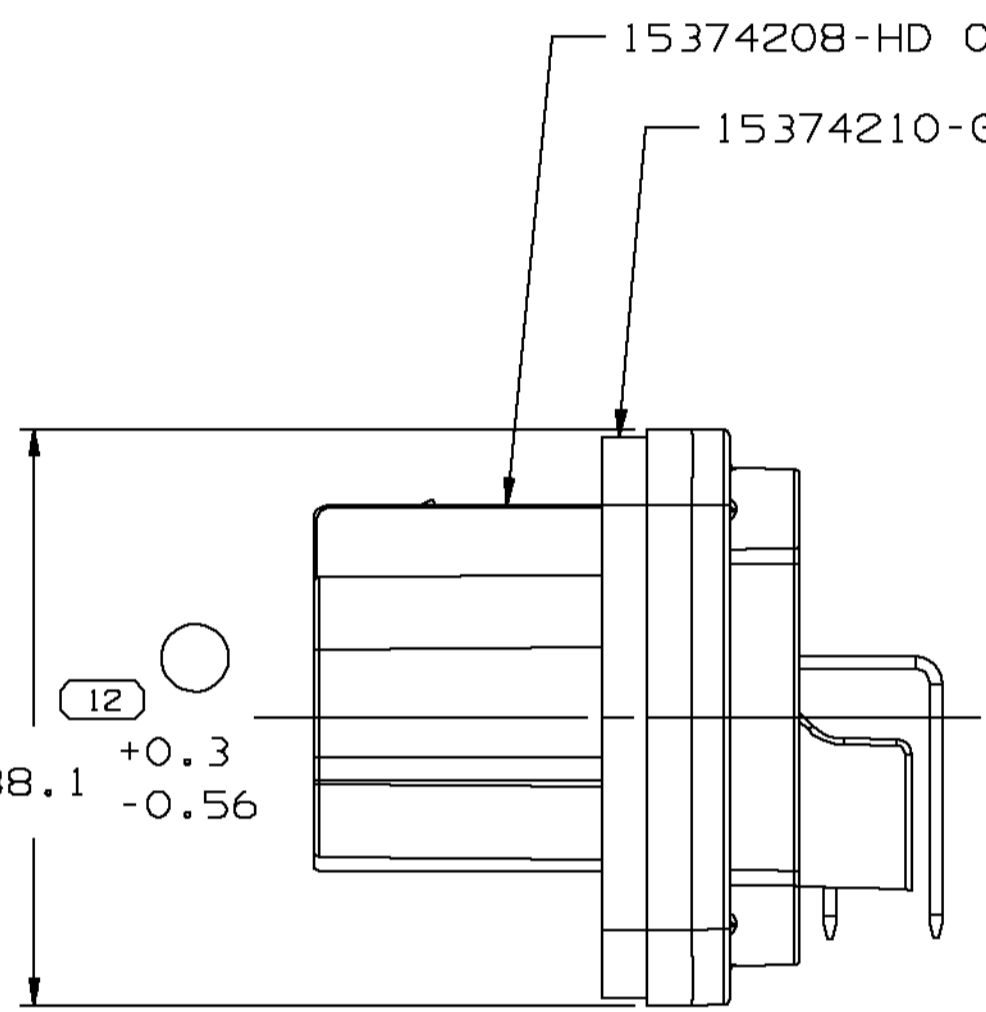
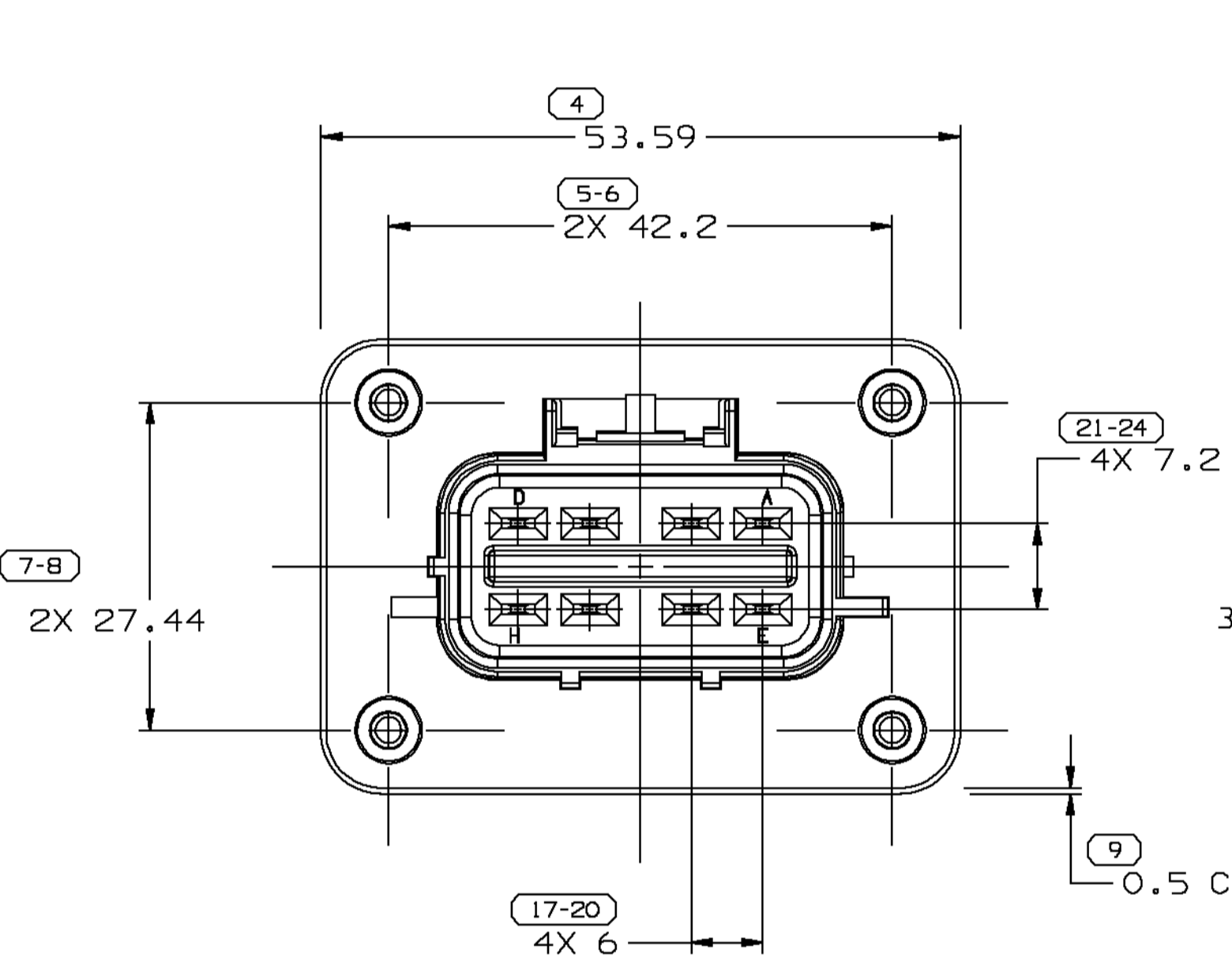
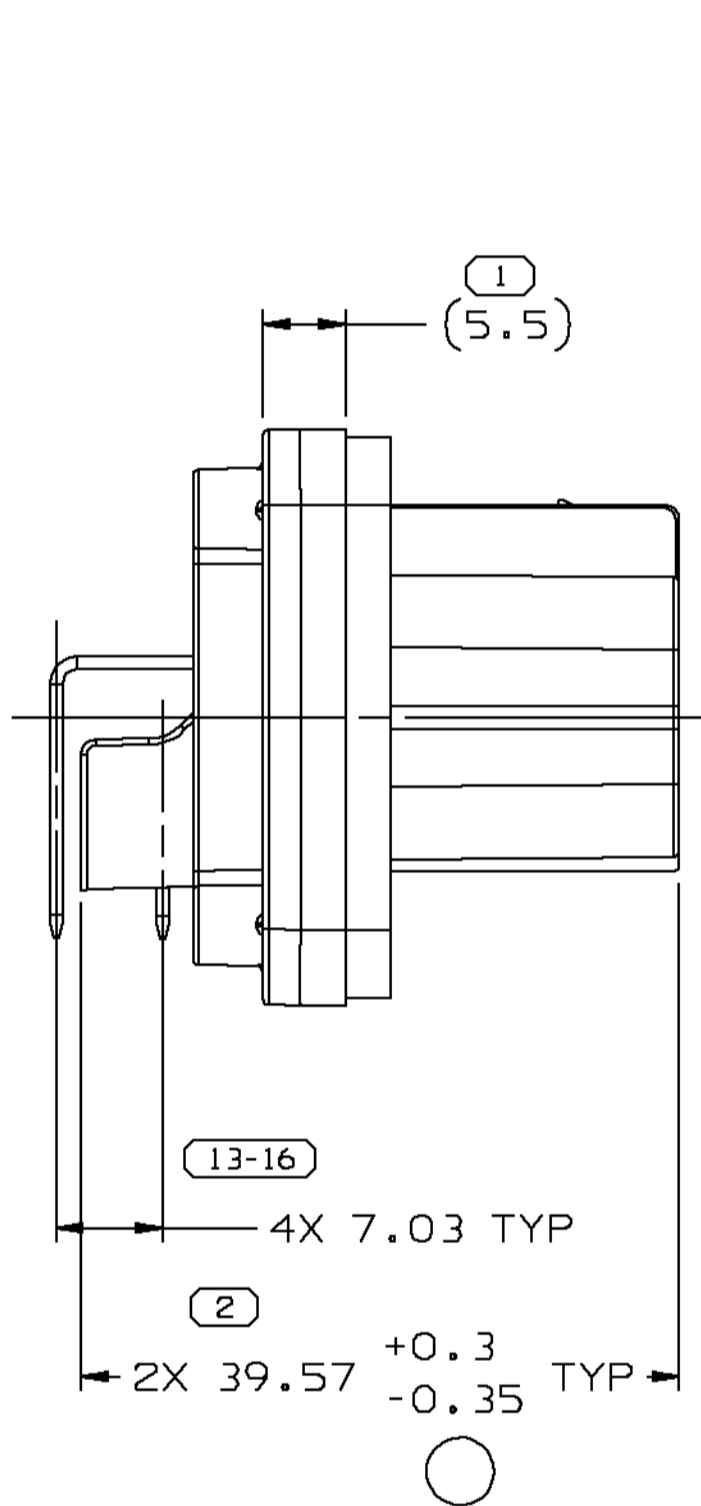
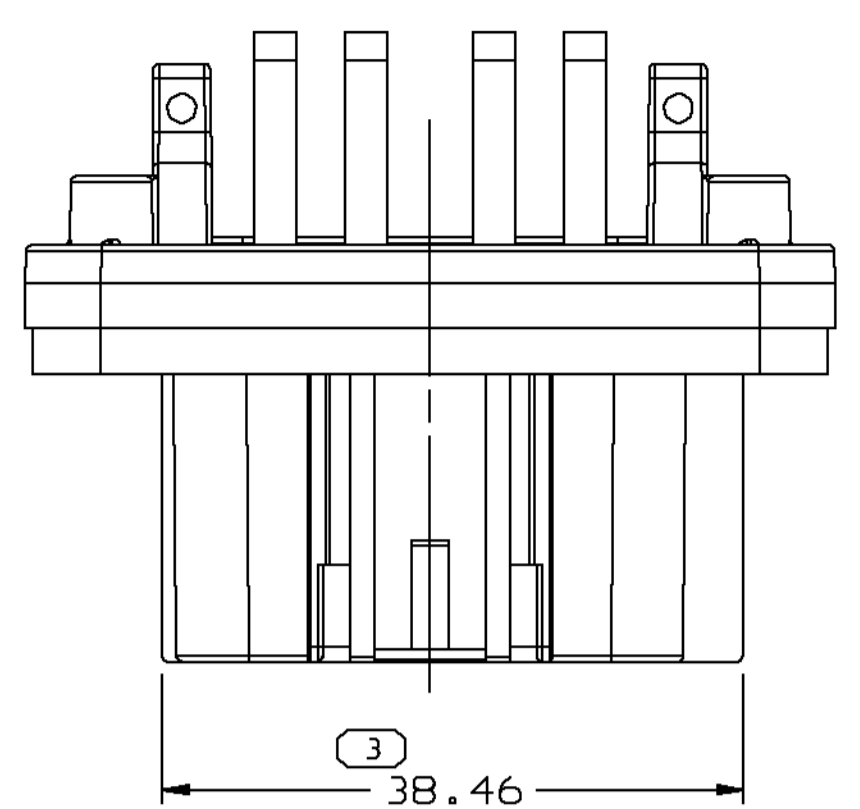

NOTES

- UNLESS OTHERWISE SPECIFIED AND/OR INDICATED: DIMENSIONS ARE TO FACE OF VIEW SHOWN AND AUTOMATICALLY ROUNDED BY COMPUTER FOR INSPECTION. (SEE MATH MODEL FOR PRECISE DIMENSIONS.) FOR ALL OTHER DIMENSIONS NOT SHOWN BUT REQUIRED FOR TOOL BUILD, SEE MATH MODEL FOR PRECISE TOOL PATH DATA.
- SEALING CODE 3 - DESIGN WILL PASS SALT FOG AND IMMERSION TEST AFTER CONDITIONING AS SPECIFIED IN ESA-644 (WEATHER-PACK), ESA-710 (METRI-PACK), ESA-650 (UNDERHOOD MICRO-PACK), C-4006 (WORLD CONNECTOR), ETC. - WHEN MATED TO MATING PART OR EQUIVALENT
- MATING COMPONENTS OR EQUIVALENT: CONNECTOR 15317304
- MATERIAL RECYCLING CODE ">PBT-GF30<" PER SAE J1344 TO APPEAR ON PART.

FROM TO	DIMENSIONAL RANGE (MM)								CHART E1
	0-20	>20-30	>30-70	>70-100	>100-150	>150-200	>200-250	>250-300	
TOLERANCE UNLESS OTHERWISE SPECIFIED									
±0.15 ±0.2 ±0.3 ±0.4 ±0.5 ±0.6 ±0.8 ±1 ±1.2									
ANGULAR TOLERANCE ± 2°									

**DELPHI**  
Automotive Systems

MATERIAL SPEC  
SEE DRAWING

SUBSTANCES OF CONCERN AND RECYCLED CONTENT PER DELPHI-A 10949001  
DISTR CODE

**PART DRAWING**

CODE NUMBER 6901	DWG DATE 09AU00	SCALE 2:1	D
QC SPEC	STYLE	VOLUME cm <sup>3</sup>	

PART GEOMETRY 3D SOLID VIRTUAL ASM

UNLESS OTHERWISE SPECIFIED:  
THIS DOCUMENT IS IN ACCORDANCE WITH ASME Y14.5M - 1994 AS AMENDED BY THE GM GLOBAL DIMENSIONING AND TOLERANCING ADDENDUM - 1997. ALL GEOMETRIC TOLERANCES AND RELATED DATUMS APPLY RFS. RULE #1 (PERFECT FORM AT MMC) DOES NOT APPLY WHEN RELATIONSHIP BETWEEN FEATURES IS ESTABLISHED BY ORIENTATION OR LOCATION TOLERANCES. SEPARATE POSITION CALLOUTS MAY BE GAGED SEPARATELY REGARDLESS OF DATUM REFERENCES.

CHANGE RESTRICTED NO MANUAL CHANGES	DATE

COPY OF MATH DATA DO NOT SCALE

REFERENCE	DR	DATE
APVD1	MICHAEL LAWRENCE	09AU00
APVD2	JUDY CUPIT	14AU00
APVD3	SHAHID MERCHANT	14AU00
APVD4		
APVD5		

METRIC UNLESS OTHERWISE SPECIFIED, ALL DIMENSIONS ARE IN MILLIMETERS

THIRD ANGLE PROJECTION

DRAWING NAME  
ASM HD CONN 8M GT 280

SHEET NUMBER 1 OF 1	DRAWING NUMBER 15374211	DWG STATUS R 003 AA	SIZE A1
------------------------	----------------------------	------------------------	------------