

SYMBOL DEFINITION		
A DIMENSION WITHOUT AN INSPECTION REPORT SYMBOL  DOES NOT REQUIRE INSPECTION. IT MAY BE CONTROLLED ON THE INDIVIDUAL COMPONENT DRAWING.	TOTAL NO OF INSPECTIONS REQUIRED	4
	LAST NO. USED	4

MISSING SYMBOLS	
NO MISSING SYMBOL NUMBER	

DWG STATUS					ZONE	REVISION HISTORY				AUTH	DR	APVD 1	APVD 2
DATE	STG	REV	N/P	CHG									
10MY02	R	02	-	-		CLEARED REVISION COLUMN. ADDED APPROACH RAMP TO DETENT & INCREASED SLOT LENGTH.				225262	RJD	RJD	BA
12DE02	R	03	-	-		REVISED DIM 4				234577	DME	DME	BA
210C03	R	03	AA	-		CORRECTED MAT'L "M2965008" WAS R0100201 PPA IM - BLU.				247683	LMB	LMB	BGA

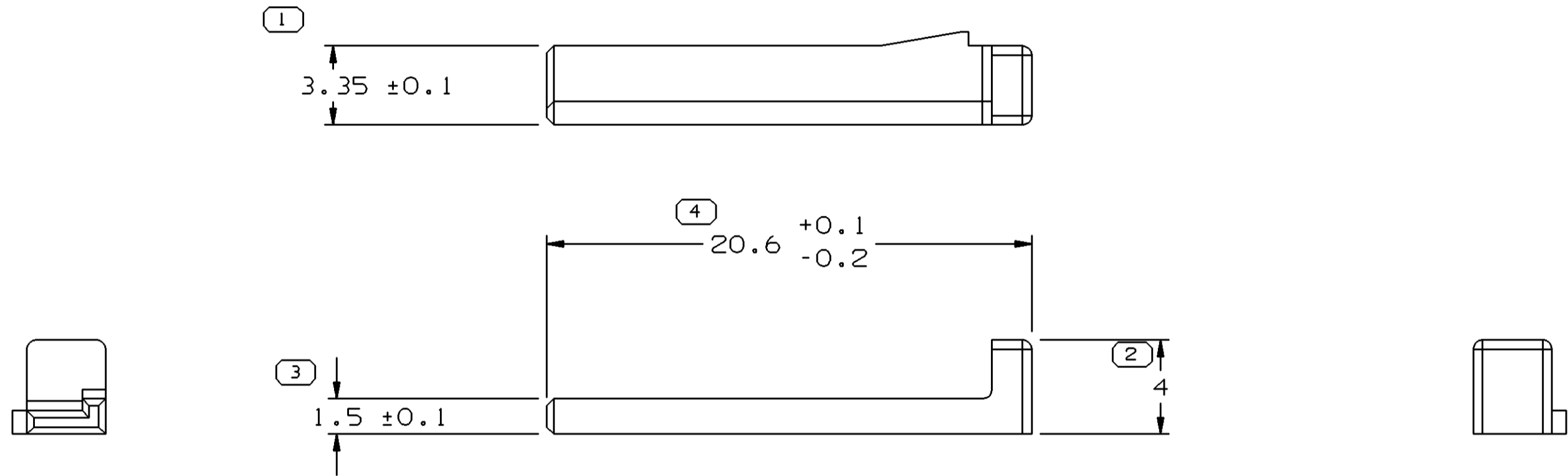

- NOTES
- UNLESS OTHERWISE SPECIFIED AND/OR INDICATED: DIMENSIONS ARE TO FACE OF VIEW SHOWN AND AUTOMATICALLY ROUNDED BY COMPUTER FOR INSPECTION (SEE MATH MODEL FOR PRECISE DIMENSIONS). FOR ALL OTHER DIMENSIONS NOT SHOWN BUT REQUIRED FOR TOOL BUILD, SEE MATH MODEL FOR PRECISE TOOL PATH DATA.
 - MATING COMPONENTS OR EQUIVALENT: CONNECTOR - 15419391

DWG TYPE		PART DRAWING	
STYLE			
VOLUME (CM ³)	0.095	DISTR CODE	D
ROUTING	6900		
UNLESS OTHERWISE SPECIFIED			
THIS DOCUMENT IS IN ACCORDANCE WITH ASME Y14.5M-1994 AS AMENDED BY THE GM GLOBAL DIMENSIONING AND TOLERANCING ADDENDUM - 1997. ALL GEOMETRIC TOLERANCES AND RELATED DATUMS APPLY RFS. RULE #1 (PERFECT FORM AT MMC) DOES NOT APPLY WHEN RELATIONSHIP BETWEEN FEATURES IS ESTABLISHED BY ORIENTATION OR LOCATION TOLERANCES. SEPARATE POSITION CALLOUTS MAY BE GAGED SEPARATELY, REGARDLESS OF DATUM REFERENCE.			
ALL DIMENSIONS ARE IN MILLIMETERS			
REFERENCE			

DELPHI

DELPHI PACKARD ELECTRIC SYSTEMS
WARREN, OH

DATE	
DR B. ANGELO	100C01
APVD1 JOE SUDIK	190C01
APVD2 JOE SUDIK	190C01
APVD3 B. ANGELO	220C01
APVD4	
APVD5	

SUBSTANCES OF CONCERN AND RECYCLED CONTENT PER DELPHI 10949001

MATERIAL
M2965008

DRAWING NAME
LOCK TPA M/P 480 2 BLU

DRAWING NUMBER
15419807

SIZE	SCALE	FRAME NO	SHEET NO	STG	REV	N/P
A2	5:1	1 OF 1	1 OF 1	R	03	AA

 PROCESS SENSITIVE DIMENSION																																												
DIMENSIONS ENCLOSED IN () INDICATE REFERENCE DIMENSIONS AND NO TOLERANCE LIMITS ARE ESTABLISHED																																												
<table border="1"> <thead> <tr> <th colspan="2">DIMENSIONAL RANGE (MM)</th> <th colspan="2">CHART E1</th> </tr> <tr> <th>FROM</th> <th>TO</th> <th>TOLERANCE UNLESS OTHERWISE SPECIFIED</th> <th>ANGULAR TOLERANCE ±2°</th> </tr> </thead> <tbody> <tr> <td>> 0</td> <td>> 20</td> <td>±0.15</td> <td></td> </tr> <tr> <td>> 20</td> <td>> 30</td> <td>±0.2</td> <td></td> </tr> <tr> <td>> 30</td> <td>> 70</td> <td>±0.3</td> <td></td> </tr> <tr> <td>> 70</td> <td>> 100</td> <td>±0.4</td> <td></td> </tr> <tr> <td>> 100</td> <td>> 150</td> <td>±0.5</td> <td></td> </tr> <tr> <td>> 150</td> <td>> 200</td> <td>±0.6</td> <td></td> </tr> <tr> <td>> 200</td> <td>> 250</td> <td>±0.8</td> <td></td> </tr> <tr> <td>> 250</td> <td>> 300</td> <td>±1</td> <td></td> </tr> <tr> <td>> 300</td> <td>> 400</td> <td>±1.2</td> <td></td> </tr> </tbody> </table>	DIMENSIONAL RANGE (MM)		CHART E1		FROM	TO	TOLERANCE UNLESS OTHERWISE SPECIFIED	ANGULAR TOLERANCE ±2°	> 0	> 20	±0.15		> 20	> 30	±0.2		> 30	> 70	±0.3		> 70	> 100	±0.4		> 100	> 150	±0.5		> 150	> 200	±0.6		> 200	> 250	±0.8		> 250	> 300	±1		> 300	> 400	±1.2	
DIMENSIONAL RANGE (MM)		CHART E1																																										
FROM	TO	TOLERANCE UNLESS OTHERWISE SPECIFIED	ANGULAR TOLERANCE ±2°																																									
> 0	> 20	±0.15																																										
> 20	> 30	±0.2																																										
> 30	> 70	±0.3																																										
> 70	> 100	±0.4																																										
> 100	> 150	±0.5																																										
> 150	> 200	±0.6																																										
> 200	> 250	±0.8																																										
> 250	> 300	±1																																										
> 300	> 400	±1.2																																										

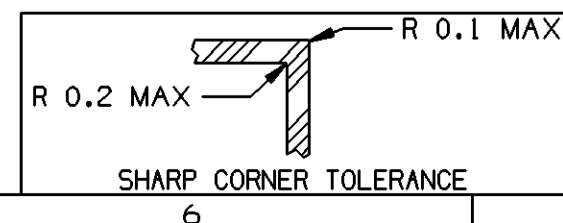

THIRD ANGLE PROJECTION

DO NOT SCALE

USE MATH DATA

