

SYMBOL DEFINITION		MISSING SYMBOLS	
A DIMENSION WITHOUT AN INSPECTION REPORT SYMBOL DOES NOT REQUIRE INSPECTION. IT MAY BE CONTROLLED ON THE INDIVIDUAL COMPONENT DRAWING.	TOTAL NO OF INSPECTIONS REQUIRED	NO MISSING SYMBOL NUMBER	
	18		
	LAST NO. USED		
	14		

DWG STATUS					REVISION HISTORY				AUTH	DR	APVD	APVD
DATE	STG	REV	N/P	CHG	ZONE							
19SE03	R	01	-	-		12064863 - WAS SEPARATE DWG: 15479379 - RELEASED		246122	ARA	RVP	GMC	
10DE03	R	02	-	-		12064863 MATERIAL SPEC WAS M3596012 TOD ONLY		249941	RH	RH	BG	

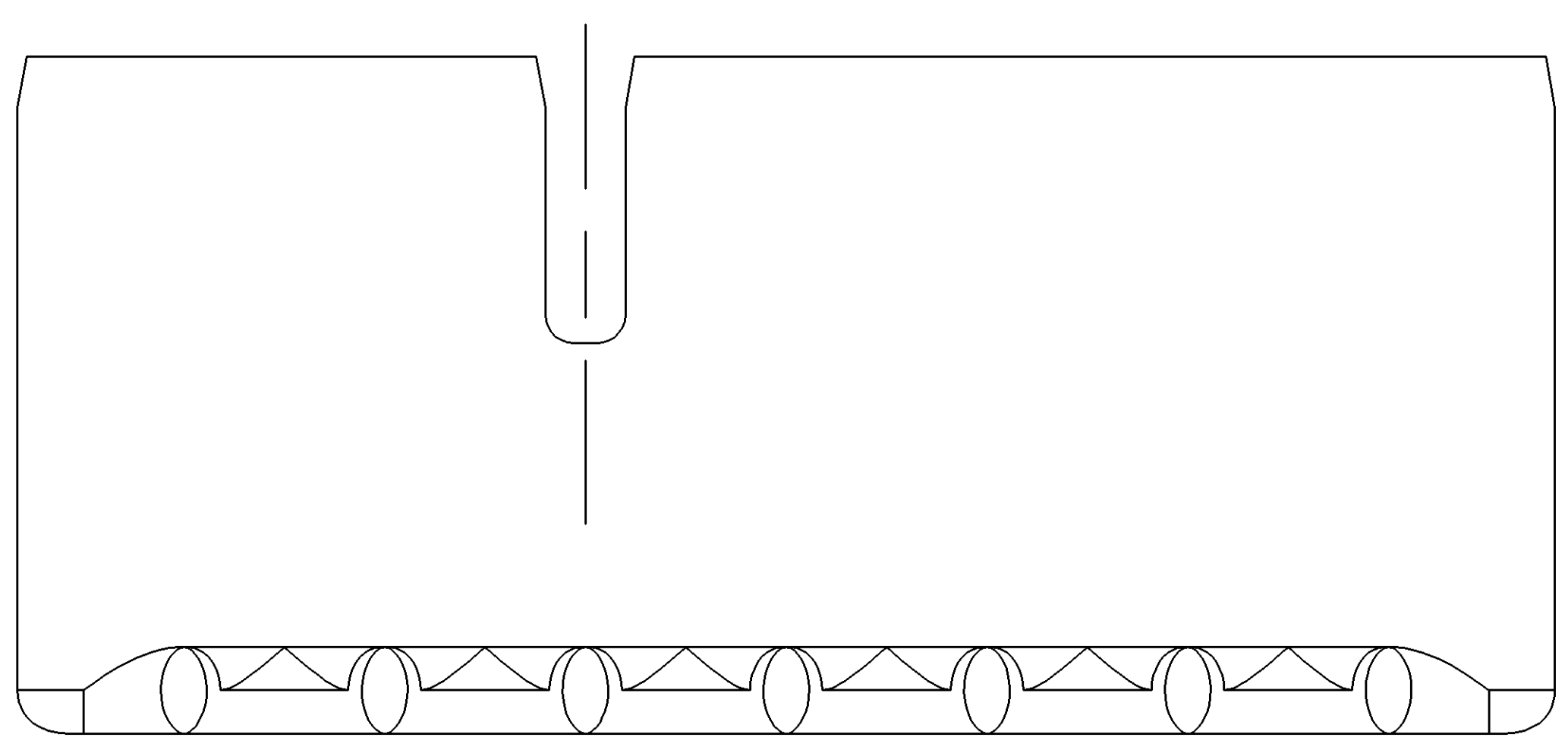
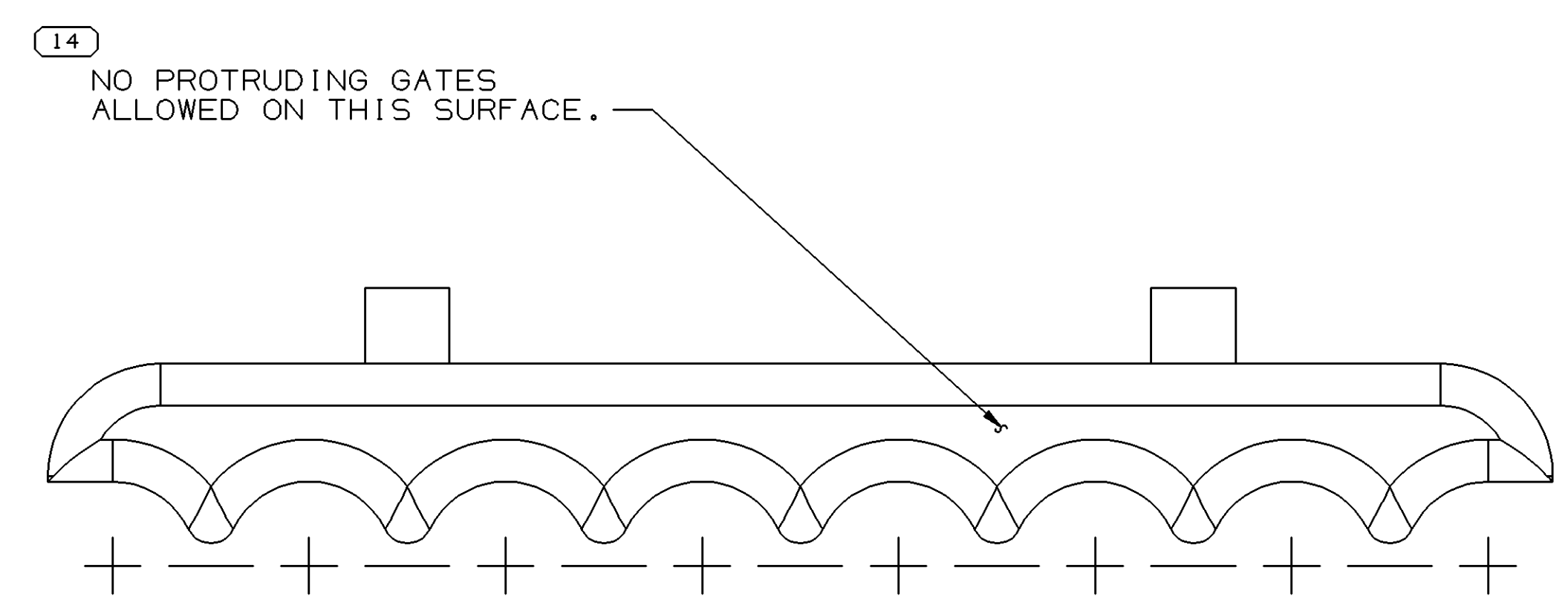
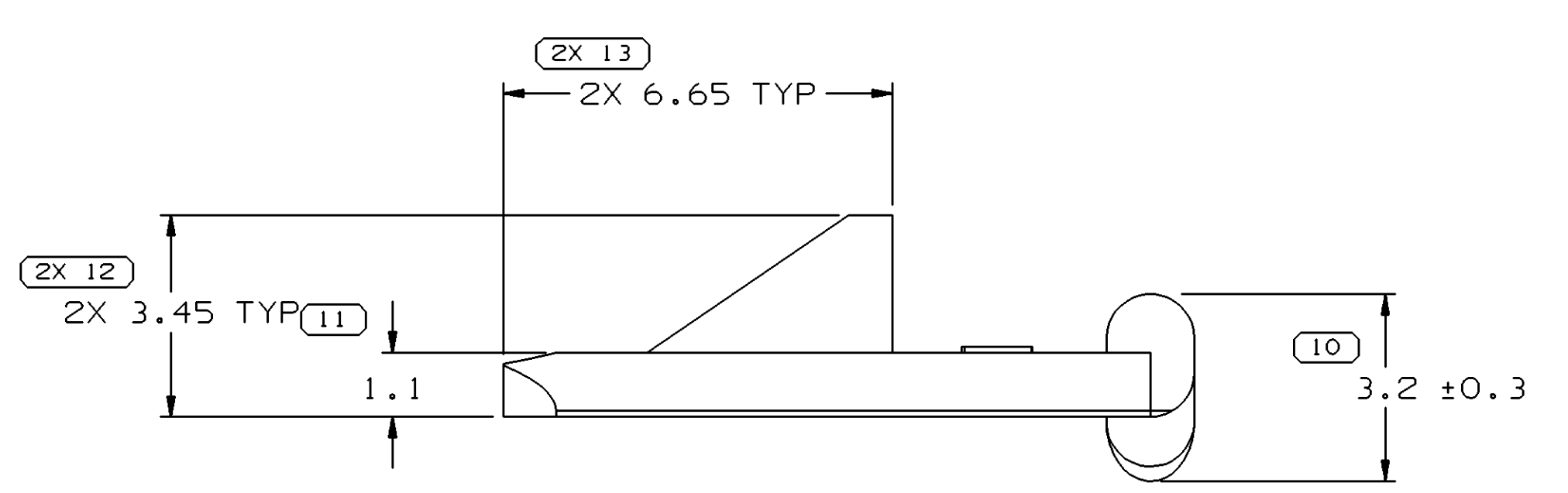
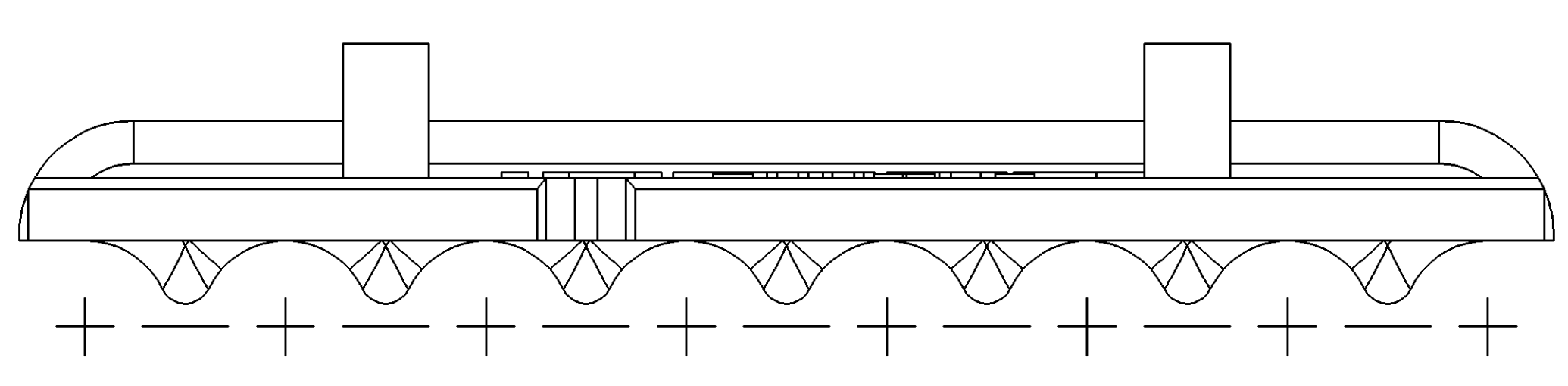
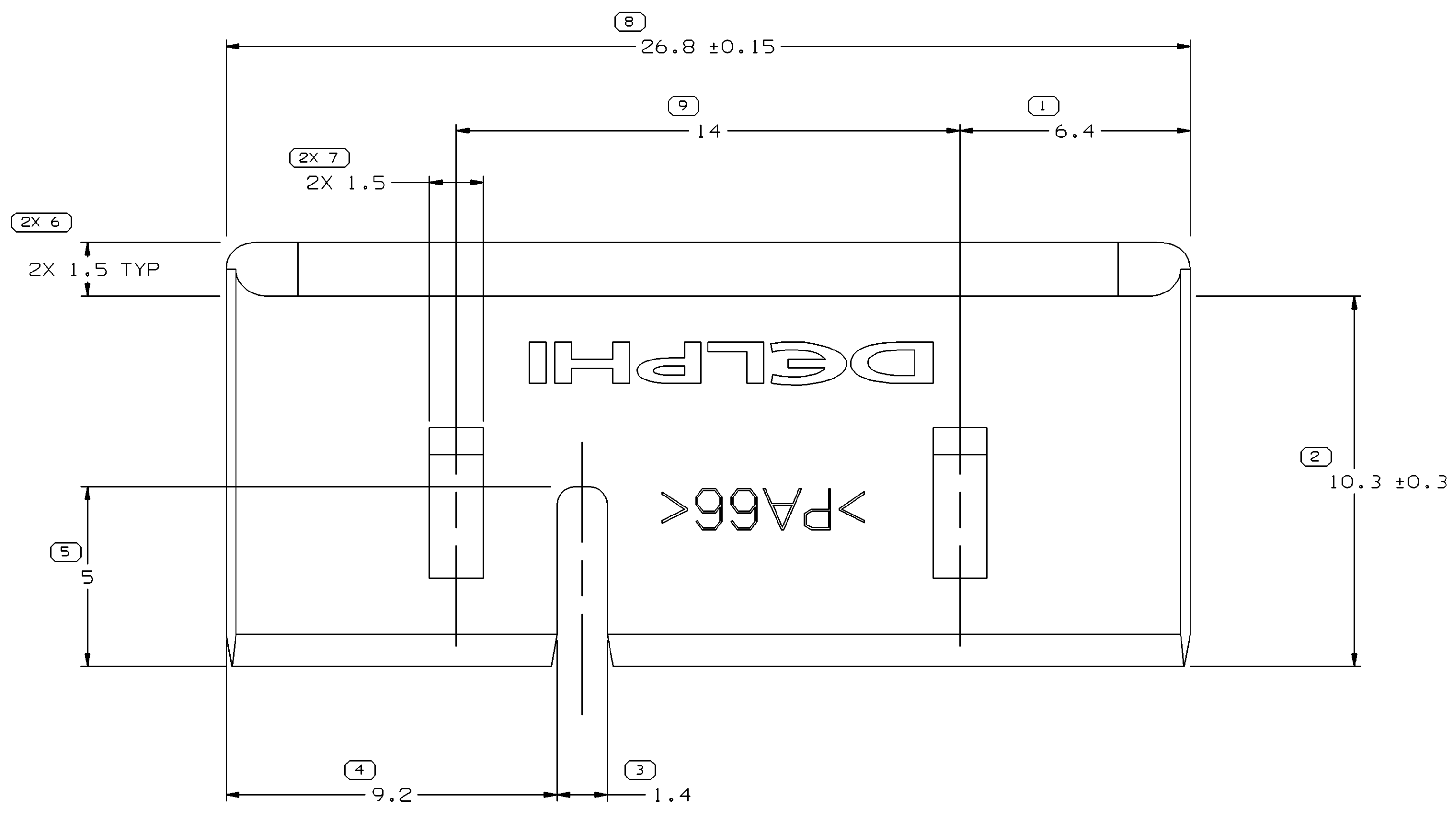

- NOTES
- UNLESS OTHERWISE SPECIFIED AND/OR INDICATED: DIMENSIONS ARE TO FACE OF VIEW SHOWN AND AUTOMATICALLY ROUNDED BY COMPUTER FOR INSPECTION (SEE MATH MODEL FOR PRECISE DIMENSIONS). FOR ALL OTHER DIMENSIONS NOT SHOWN BUT REQUIRED FOR TOOL BUILD, SEE MATH MODEL FOR PRECISE TOOL PATH DATA.
  - MATERIAL RECYCLING CODE PER ISO 11469. (2.31X(0.1) RAISED CHARACTERS AS SHOWN TO BE LOCATED ON ANY EXTERIOR SURFACE. OPTIONAL CONSTRUCTION TO BE NO MATERIAL RECYCLING CODE.
  - THIS PART IS NOT CONTROLLED FOR AUTOMATIC FEEDING.
  - MATING COMPONENTS OR EQUIVALENT: CONNECTOR 12064862
  - (2.31X(0.1) RAISED DELPHI CORPORATE BRAND TO BE LOCATED ON ANY EXTERIOR SURFACE, PREFERABLY VISIBLE AT FINAL ASSEMBLY. OPTIONAL CONSTRUCTION TO BE "PED" OR NO LOGO.

PART NO	REV	N/P	STATUS	MATERIAL SPECIFICATION AND COLOR	VOLUME CM <sup>3</sup>
15479379	01	-		M3592001 PA66 HS IM BLK	0.394
12064863	02	AB		M3592012 PA66 HS IM GRA LT	0.394

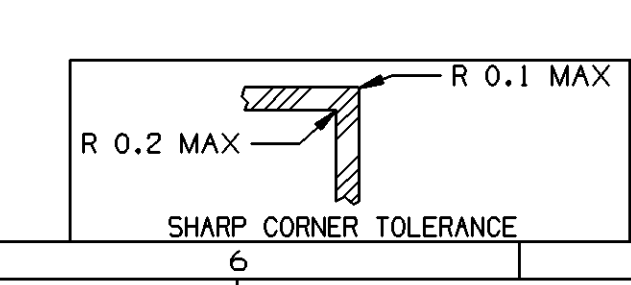

DIMENSIONAL RANGE (MM)	TOLERANCE UNLESS OTHERWISE SPECIFIED
FROM 0 TO > 20	±0.3
> 20 TO > 30	±0.3
> 30 TO > 70	±0.4
> 70 TO > 100	±0.5
> 100 TO > 150	±0.6
> 150 TO > 200	±0.8
> 200 TO > 250	±1
> 250 TO > 300	±1.2
> 300 TO > 400	±1.5

DWG TYPE		PART DRAWING	
STYLE	SEE CHART	DISTR CODE	D
VOLUME (00 <sup>3</sup> )	6900		
ROUTING			
UNLESS OTHERWISE SPECIFIED			
THIS DOCUMENT IS IN ACCORDANCE WITH ASME Y14.5M-1994 AS MODIFIED BY THE 2003 DIMENSIONING AND TOLERANCING ADDENDUM (2003). SEPARATE PATTERNING OF FEATURES MAY BE OBTAINED SEPARATELY REGARDLESS OF DATUM REFERENCE.			
ALL DIMENSIONS ARE IN MILLIMETERS			
REFERENCE			

**DELPHI**  
DELPHI PACKARD ELECTRIC SYSTEMS  
WARREN, OH

DR	DATE
APVD1 A. ALVIDREZ	19SE03
APVD2 R. VILLANUEVA	23SE03
APVD3 G. MACIAS	26SE03
APVD4	
APVD5	

SUBSTANCES OF CONCERN AND RECYCLED CONTENT PER DELPHI 10949001

MATERIAL

SEE CHART

DRAWING NAME  
TAXI LOCK TPA M/P 150 BLK

DRAWING NUMBER  
15479380

SIZE	SCALE	FRAME NO	SHEET NO	STG	REV	N/P
A0	5:1	1	1	1	R	02