

SYMBOL DEFINITION	
A DIMENSION WITHOUT AN INSPECTION REPORT SYMBOL () DOES NOT REQUIRE INSPECTION. IT MAY BE CONTROLLED ON THE INDIVIDUAL COMPONENT DRAWING.	TOTAL NO OF INSPECTIONS REQUIRED
	6
	LAST NO. USED
	6

MISSING SYMBOLS					DWG STATUS					REVISION HISTORY			AUTH	DR	APVD 1	APVD 2
DATE	STG	REV	N/P	CHG	ZONE	DATE	REV	BY	REASON							
02AU04	R	01	-	-					RELEASED				257551	MDH	AUG	SAN
140C05	R	01	AA	-					DIM 10.2 ±1 WAS 10.2 ±0.3				273569	GFS	JAA	TP

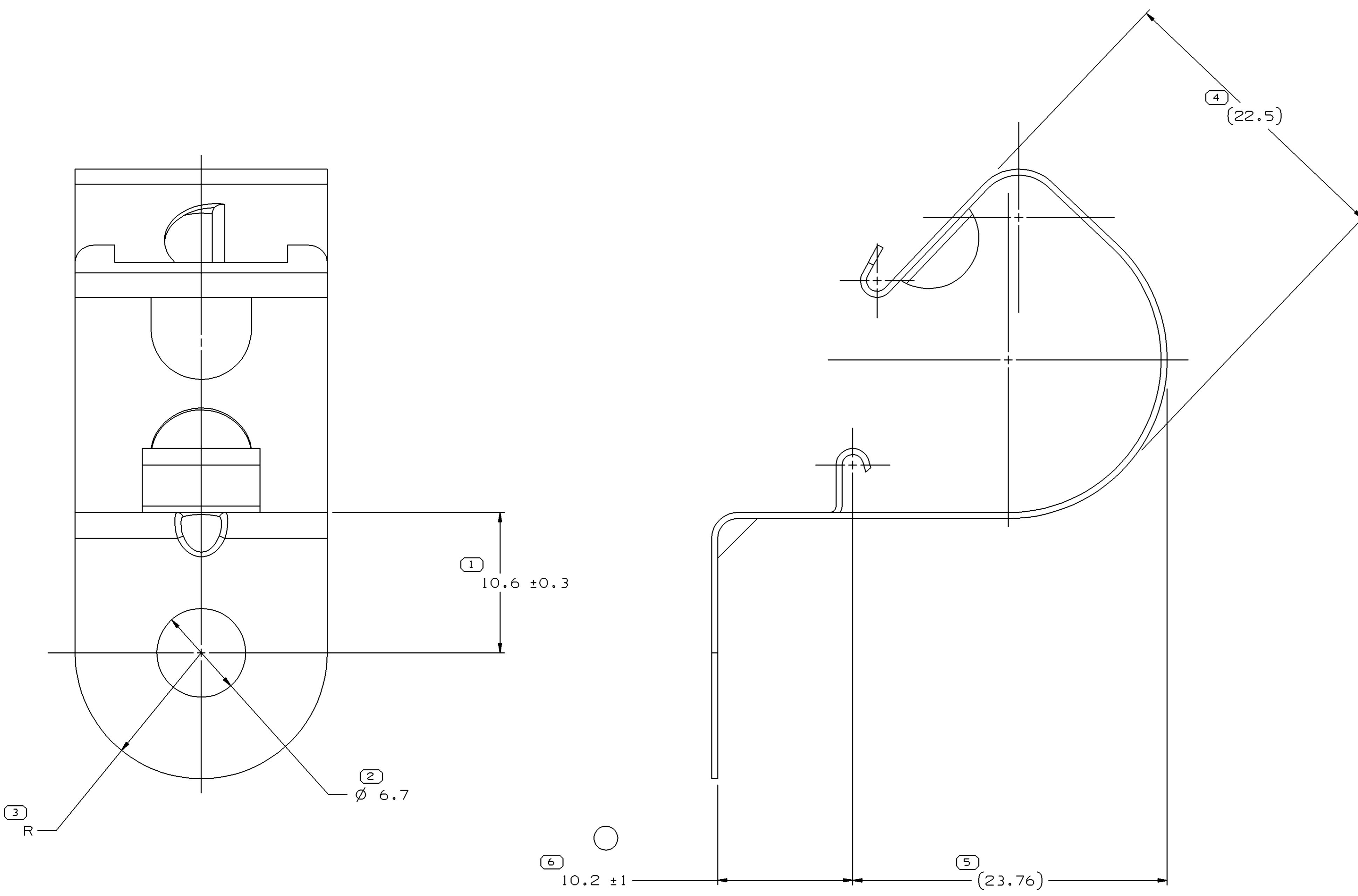

NOTES

- UNLESS OTHERWISE SPECIFIED AND/OR INDICATED:
DIMENSIONS ARE TO FACE OF VIEW SHOWN AND AUTOMATICALLY ROUNDED BY COMPUTER FOR INSPECTION (SEE MATH MODEL FOR PRECISE DIMENSIONS). FOR ALL OTHER DIMENSIONS NOT SHOWN BUT REQUIRED FOR TOOL BUILD, SEE MATH MODEL FOR PRECISE TOOL PATH DATA.
- (2.3)X(0.1) DELPHI CORPORATE BRAND TO BE LOCATED ON ANY EXTERIOR SURFACE, PREFERABLY VISIBLE AT FINAL ASSEMBLY. OPTIONAL CONSTRUCTION TO BE "PED".
- ALL FORMED DIMENSIONS ARE TO BE CHECKED AFTER HEAT TREATING.
- ANGULAR TOLERANCE ±3°

NOTES

- TEMPER TO ROCKWELL 15N 81.5-83.5
- PLATE PER DX551245-P ZINC WITH CLEAR TRIVALENT CHROME & TOPCOAT

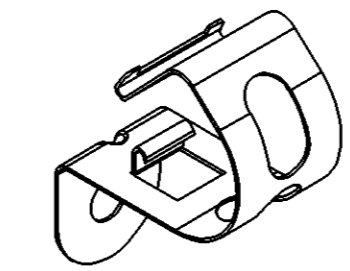

(6)	PROCESS SENSITIVE DIMENSION
DIMENSIONS ENCLOSED IN () INDICATE REFERENCE DIMENSIONS AND NO TOLERANCE LIMITS ARE ESTABLISHED	
DIMENSIONAL RANGE (MM)	CHART 6
FROM 0 TO 12	> 12
TOLERANCE UNLESS OTHERWISE SPECIFIED ±0.15	±0.3
ANGULAR TOLERANCE ±2°	

DWG TYPE		PART DRAWING	
STYLE			
VOLUME (CM³)		DISTR CODE	
		D	
UNLESS OTHERWISE SPECIFIED			
THIS DOCUMENT IS IN ACCORDANCE WITH ASME Y14.5M-1994 AS AMENDED BY THE GM GLOBAL DIMENSIONING AND TOLERANCING ADDENDUM-2001. SEPARATE PATTERNS OF FEATURES MAY BE GAGED SEPARATELY REGARDLESS OF DATUM REFERENCES.			
ALL DIMENSIONS ARE IN MILLIMETERS			
REFERENCE			
THIRD ANGLE PROJECTION		DO NOT SCALE	
USE MATH DATA		UNIGRAPHICS	

DELPHI			
DELPHI PACKARD ELECTRIC SYSTEMS WARREN, OH			
DR		DATE	
APVD1	M. DE JESUS	25AU04	
APVD2	A. UGALDE	27AU04	
APVD3	S. NORLING	29AU04	
APVD4			
APVD5			
SUBSTANCES OF CONCERN AND RECYCLED CONTENT PER DELPHI 10949001			
MATERIAL 0.455 THK. SAE 1050 C.R. STEEL			
DRAWING NAME MOUN CLAMP CDT 13MM			
DRAWING NUMBER 15495892			
SIZE	SCALE	FRAME NO	SHEET NO
A1	5:1	1 OF 1	1 OF 1
STG	REV	N/P	AA
R	01		