

SYMBOL DEFINITION		MISSING SYMBOLS	
A DIMENSION WITHOUT AN INSPECTION REPORT SYMBOL  DOES NOT REQUIRE INSPECTION. IT MAY BE CONTROLLED ON THE INDIVIDUAL COMPONENT DRAWING.	TOTAL NO OF INSPECTIONS REQUIRED	6	1 3-10 12-13 16-19
	LAST NO. USED	20	

DWG STATUS				ZONE	REVISION HISTORY	AUTH	DR	APVD1	APVD2
DATE	STG	REV	N/P						
04AU04	R	03	-	-	CLEARED REV COL AND 15496311 - RELEASED	257692	RTV	JVM	SAN
26JA05	R	04	-	-	15496311 - REVISED PROCESS NOTE #3	263856	EES	EES	TP
15AP05	R	05	-	-	15496311 - ADDED DIM #20 AND ADDED PROCESS NOTE #4	266999	CCV	FRG	TP
190C05	R	06	-	-	12129847 - OBSOLETE	273757	JTZ	JAA	PGD
28FE06	R	07	-	-	12129846 - OBSOLETE; 15496311 - REMOVED DIMS AND ADDED DIMPLES	276746	RMG	FRG	TP

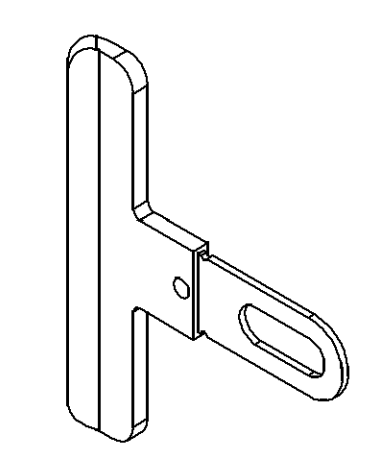
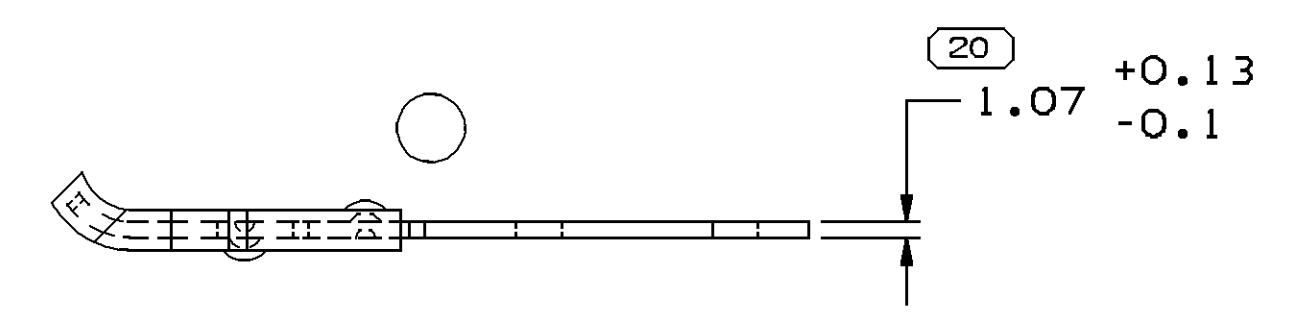
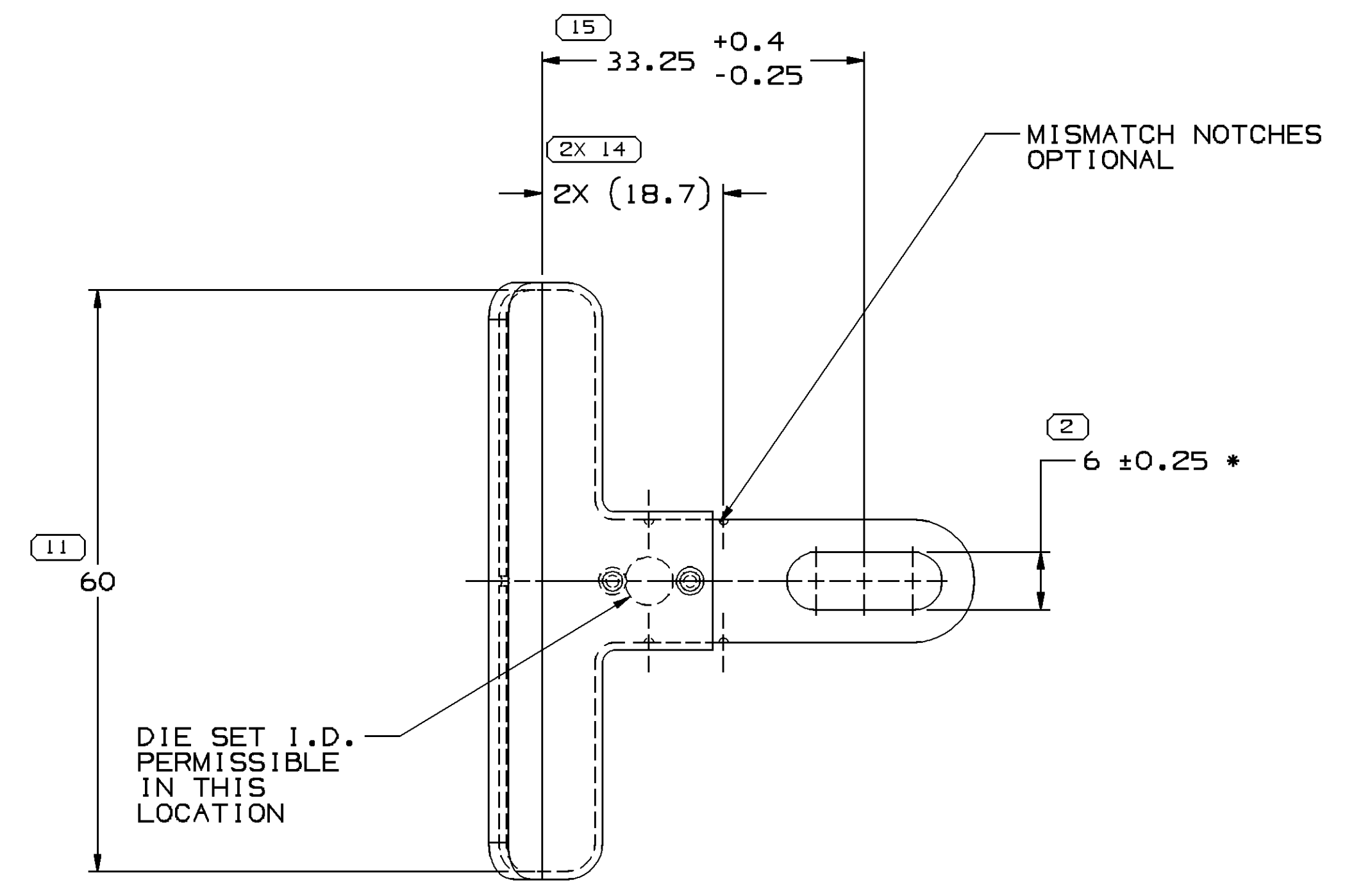

NOTES

- UNLESS OTHERWISE SPECIFIED AND/OR INDICATED:
DIMENSIONS ARE TO FACE OF VIEW SHOWN AND AUTOMATICALLY ROUNDED BY COMPUTER FOR INSPECTION (SEE MATH MODEL FOR PRECISE DIMENSIONS). FOR ALL OTHER DIMENSIONS NOT SHOWN BUT REQUIRED FOR TOOL BUILD, SEE MATH MODEL FOR PRECISE TOOL PATH DATA.
- "*" INDICATES AREA MUST BE VOID OF VINYL.

PROCESS NOTES

- MATERIAL IS PRE-PLATED GALVANIZED, G90, WITH 0.00072" MIN COATING PER SIDE. PLATING TO WITHSTAND 300 HRS MIN TO RED RUST IN NEUTRAL SALT FOG, EXCEPT FOR "SHARP" EDGES
- BLACK VINYL COATING TO BE 1.2/0.4 THICK AS SHOWN.
- PRE-PLATED G90 MATERIAL PER SPEC M4869 ASTM A653 SS GRD 50 MATERIAL THICKNESS: 1.07MM
- PLATING TO WITHSTAND 300 HOURS MIN TO RED RUST IN NEUTRAL SALT FOG, EXCEPT FOR SHARP EDGES.

PART NO.	REV	N/P	STATUS	SIZE	SPEC.	MATERIAL	PART NO.	REV	N/P	STATUS	PROCESS NOTES
12129846	D1		OBSOLETE	1.07 THK	1008-21 #2T	15496311 02	12129847	D1		OBSOLETE	2, 3 & 4
UNPLATED						VINYL COATED					

(N/A) PROCESS SENSITIVE DIMENSION	
DIMENSIONS ENCLOSED IN () INDICATE REFERENCE DIMENSIONS AND NO TOLERANCE LIMITS ARE ESTABLISHED	
DIMENSIONAL RANGE (MM)	CHART
FROM 0	> 12
TO 12	
TOLERANCE UNLESS OTHERWISE SPECIFIED	
±0.15	±0.3
ANGULAR TOLERANCE #2*	

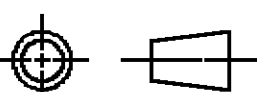
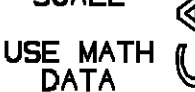
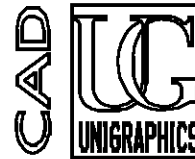
DWG TYPE PART DRAWING	
STYLE	
VOLUME (QTY)	DISTR CODE
	D
UNLESS OTHERWISE SPECIFIED THIS DOCUMENT IS IN ACCORDANCE WITH ASME Y14.5M-1994 AS AMENDED BY THE 3M GLOBAL DIMENSIONING AND TOLERANCING ADDENDUM-2001. SEPARATE PATTERNS OF FEATURES MAY BE BAGGED SEPARATELY REGARDLESS OF DATUM REFERENCES.	
ALL DIMENSIONS ARE IN MILLIMETERS	
THIRD ANGLE PROJECTION	DO NOT SCALE
	
USE MATH DATA	

DELPHI	
DELPHI PACKARD ELECTRIC SYSTEMS WARREN, OH	
DR	DATE
APVD1 JOE SUDIK	10AP92
APVD2 T. MUDREY	28AP92
APVD3 A. RASCHILLA	29AP92
APVD4	
APVD5	
SUBSTANCES OF CONCERN AND RECYCLED CONTENT PER DELPHI 10949001	
MATERIAL SEE CHART	
DRAWING NAME TAXI MOUN CLIP TAPE ON OVAL HOLE	
DRAWING NUMBER 12129845	
SIZE A1	SCALE 2:1
FRAME NO 1 OF 1	SHEET NO 1 OF 1
STG R	REV 07
N/P -	