

SCREW => 160-580-9.7SCRW

1. MATERIAL :
- 1-1. SCREW : BRASS
 - 1-2. WASHER : STEEL, ZINC PLATED
 - 1-3. NUT : STEEL, ZINC PLATED
2. FINISH :
- 2-1. SCREW :100u" NICKEL PLATED

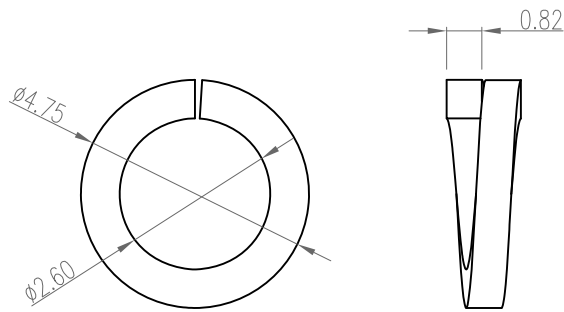

LOCK WASHER => LW3Z

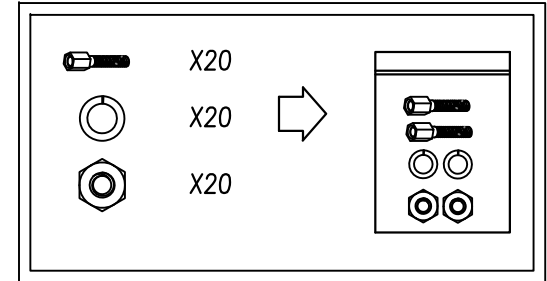
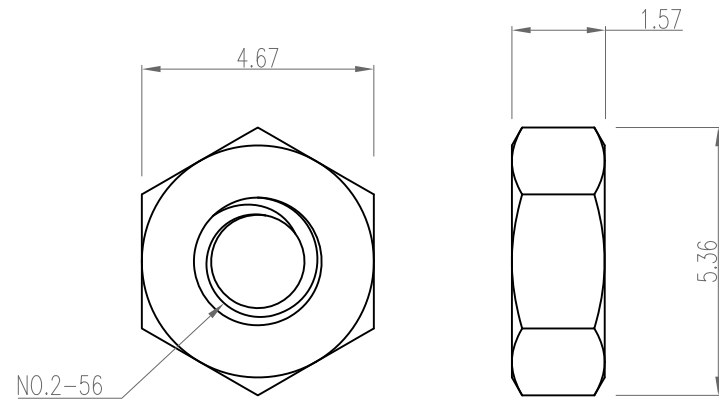

NUT => N256Z

RoHS COMPLIANT

UNITS = mm

DO NOT SCALE FROM DRAWING



THESE DRAWINGS AND SPECIFICATIONS ARE THE PROPERTY OF NorComp AND SHALL NOT BE REPRODUCED, COPIED OR USED AS THE BASIS FOR THE MANUFACTURE OR SALE OF APPARATUS WITHOUT WRITTEN PERMISSION.

DRAWN:

J. KADEL

DATE:

08/24/2020

NorComp

SCALE:
NTS

SHEET OF
1 OF 1

REV
0

DWG NO.

160-580-JSLRKT1