



Features

- Fits single or dual conduit ports
- Weatherproof
- Long life, high operational reliability
- Stainless steel construction
- RoHS compliant*

1669 Series – Transient Protector

Used for full weather protection of field transmitters and instrumentation operating on 12-28 V systems, the 1669 Series protects sensitive I/O circuitry from surges of any polarity or magnitude. Principal use is on 4-20 mA control loops and can be used on grounded (+ or -) or ungrounded circuits. Able to survive and protect even from direct lightning strikes to the transmitter ground or field wiring. Automatic recovery after passage of the surge. Long life, high operational reliability.

Construction is hybrid 3-stage design, using a high surge capacity Balanced Trigard® Gas Tube protector, coordination impedance and silicon suppressors to provide differential and common mode protection with very low clamping levels for delicate loads. The housing is thick walled schedule 40, type 303 stainless steel. Wiring is #20 (.5 mm²) 1000 V, PVC insulated. Solid red and black colors are used for the input; striped colors signify the protected output. The protector ground wire (green) is electrically bonded to the metallic housing; it is for connection to the grounding screw within the field device. Use Model 1669-02/-03/-06 for standard ground resistance conditions.

Use Model 1669-01/-05 with higher voltage isolation to ground for sites with high resistance soil conditions or where significant ground potential differences are known to exist.

Characteristics

	Model 1669-01 Model 1669-05	Model 1669-02 Model 1669-06	Model 1669-03
Warranty	3 years.....	3 years.....	3 years
Maximum Signal Voltage.....	30 Vpk.....	30 Vpk.....	13 Vpk
DC Clamping Voltage			
L-L.....	36 V.....	36 V.....	15 V
L-G.....	250 V.....	36 V.....	15 V
Capacitance, 1 MHz, max			
L-L.....	1200 pF.....	2000 pF.....	5000 pF
L-G.....	40 pF.....	2000 pF.....	5000 pF
Series Resistance, per line.....	22 Ω.....	22 Ω.....	22 Ω
Inductance, per line, max.....	1 μH.....	1 μH.....	1 μH
DC Leakage, max.....	1 μA @ 24 V.....	1 μA @ 24 V.....	1 μA @ 12 V
Impulse Clamping Voltage: L-L.....	50 V.....	50 V.....	22 V
1 kA (L+L)-G, 10/1000 μs, 500 V/μs: L-G.....	750 V.....	70 V.....	22 V
Ambient Temperature Range, Storage.....	-65 °C to +130 °C.....	-65 °C to +130 °C.....	-65 °C to +130 °C
Operating Temperature			
Non-hazardous Areas.....	-40 °C to +100 °C.....	-40 °C to +100 °C.....	-40 °C to +100 °C
Hazardous Areas.....	-20 °C to + 55 °C.....	-20 °C to + 55 °C.....	-20 °C to + 55 °C
Maximum Load Current.....	150 mA.....	150 mA.....	150 mA
- Except when limited for T5 conditions (.73 W).....	129 mA.....	129 mA.....	129 mA
Humidity	0 - 95 % Condensing.....	0 - 95 % Condensing.....	2 - 95 % Condensing
Altitude, Operating	6,000 m.....	6,000 m.....	6,000 m
Weight			
1669-01 / 02	150 g.....	150 g.....	150 g
1669-05 / 06	220 g.....	220 g.....	220 g
Surge Life (L+L)-G			
20 kA 8/20 μs.....	20 times.....	20 times.....	20 times
1 kA 10/1000 μs.....	1000 times.....	1000 times.....	1000 times



WARNING Cancer and Reproductive Harm - www.P65Warnings.ca.gov

*RoHS Directive 2015/863, Mar 31, 2015 and Annex.

Specifications are subject to change without notice.

Users should verify actual device performance in their specific applications.

The products described herein and this document are subject to specific legal disclaimers as set forth on the last page of this document, and at www.bourns.com/docs/legal/disclaimer.pdf.

1669 Series – Transient Protector

BOURNS®

Product Dimensions

1669-01, 1669-02, 1669-03

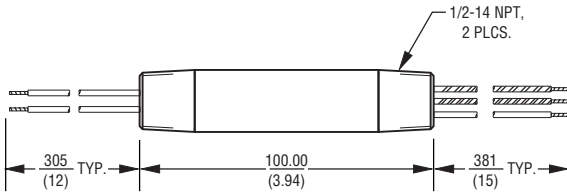

This 'double ended' type is used when the field instrument has only a single conduit entry port; the protector attaches to the instrument, and the connection to the field wiring is made inside an external, appropriately rated box connected to the other end of the protector.

1669-05, 1669-06

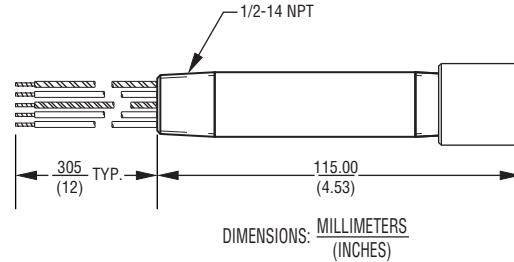

The 'single ended' protectors are useful for field devices with dual conduit ports; the field wiring connects to one port while the 1669 protector connects into the second - all connections are made within the instrument's wiring cavity. This installation simplifies the task of maintenance or of adding a protector into an existing loop.

Installation Diagrams

1669-01, 1669-02, 1669-03
(For control room protector use 1820-28-A1/A3)

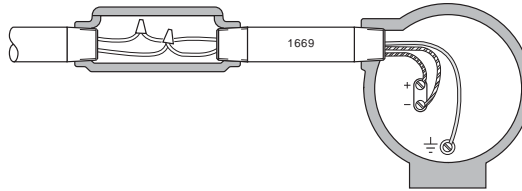

1669-05, 1669-06
(For control room protector use 1820-28-A1/A3)

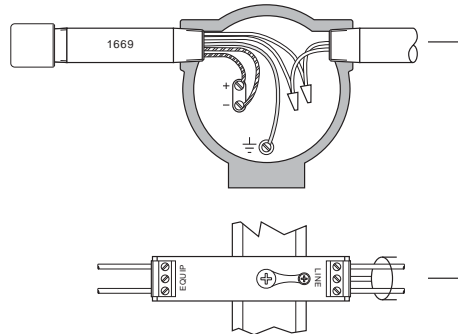

How To Order

1669 - XX

Model Number Designator

01	05
02	06
03	

REV. K 10/19

Specifications are subject to change without notice.

Users should verify actual device performance in their specific applications.

The products described herein and this document are subject to specific legal disclaimers as set forth on the last page of this document, and at www.bourns.com/docs/legal/disclaimer.pdf.