

- NOTES:
- MATERIALS:
 - CAGE: STAINLESS STEEL
 - EMI SPRINGS: COPPER ALLOY
 - HEAT SINK: NICKEL PLATED ALUMINUM
 - HEAT SINK CLIP: STAINLESS STEEL
 - FOR USE WITH IFT MODULE 172604-0002 AND -1002
 - No RoHS EXEMPTIONS.
 - PACKAGING: TRAY PACK

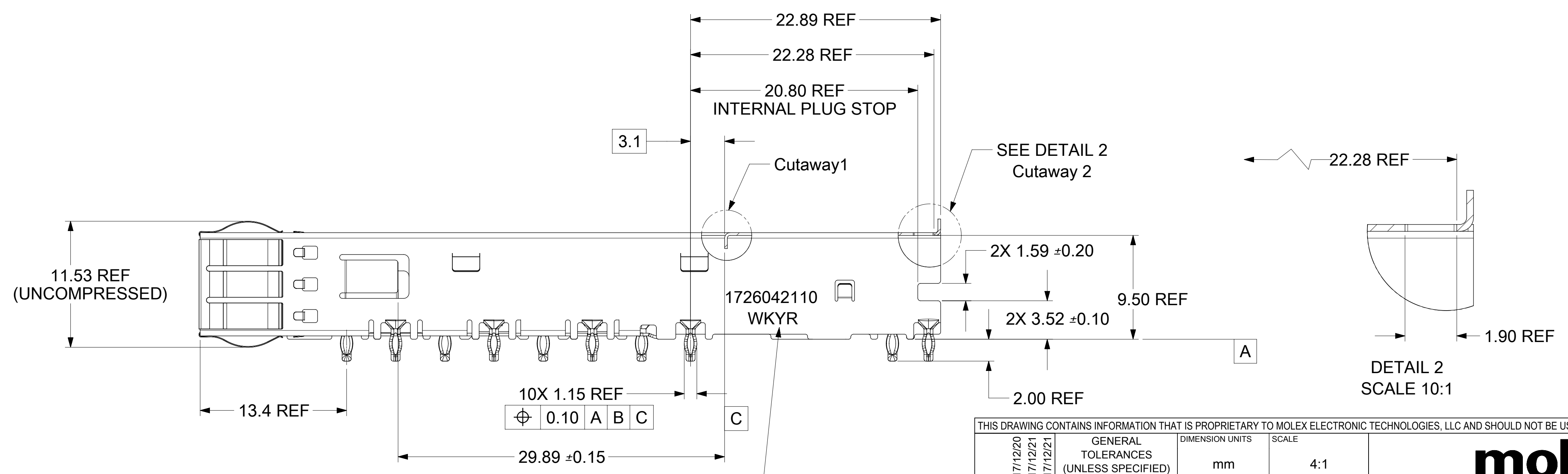
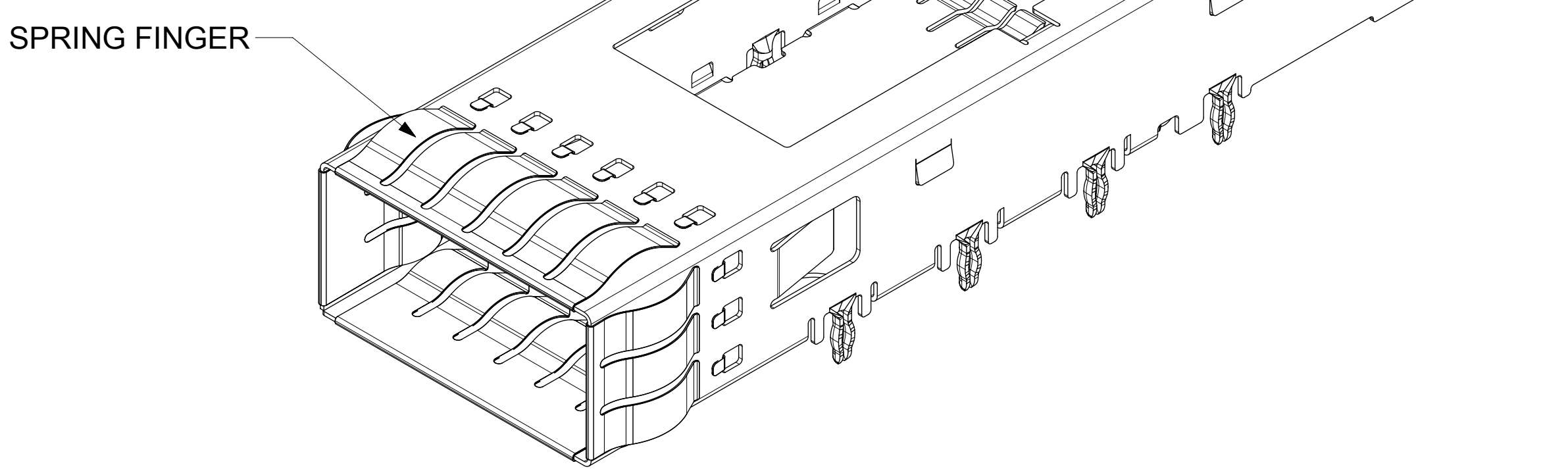

P/N AND WEEK/YEAR DATE CODE TO BE PRINTED ON SIDE OF COMPLETED CAGE ASSEMBLY APPROXIMATELY AS SHOWN SEE TABLE ABOVE FOR DATE CODE INFORMATION.

WEEK/YEAR DATE CODE TABLE	
WK	WEEK OF THE YEAR 01 THRU 52 (EXAMPLE:01=FIRST WEEK OF YEAR 52=LAST WEEK OF YEAR)
YR	17,18,19 ETC, (EXAMPLE: YEAR 2017=17)

THIS DRAWING CONTAINS INFORMATION THAT IS PROPRIETARY TO MOLEX ELECTRONIC TECHNOLOGIES, LLC AND SHOULD NOT BE USED WITHOUT WRITTEN PERMISSION

EC NO: 169860 DRWN: PGSHETTY CHKD: DSUN15 REV APPR: RCHEN08 2017/12/20 2017/12/21 2017/12/21	GENERAL TOLERANCES (UNLESS SPECIFIED) ANGULAR TOL ± 0.5 ° 4 PLACES ± 3 PLACES ± 2 PLACES ± 0.13 1 PLACE ± 0.25 0 PLACES ±	DIMENSION UNITS: mm SCALE: 4:1 DRWN BY: PGSHETTY DATE: 2017/12/20 CHKD BY: DSUN15 DATE: 2017/12/21 APPR BY: RCHEN08 DATE: 2017/12/21	PRODUCT CUSTOMER DRAWING T-CONNECTOR EMI CAGES W/HEAT SINK
	DRAFT WHERE APPLICABLE MUST REMAIN WITHIN DIMENSIONS	DRAWING SIZE: D THIRD ANGLE PROJECTION	SERIES: 172604 MATERIAL NUMBER: 1726042100 CUSTOMER:
	SEE P/N TABLE	DIMENSION UNITS: mm SCALE: 4:1	PRODUCT CUSTOMER DRAWING T-CONNECTOR EMI CAGES W/HEAT SINK
	DIMENSION UNITS: mm SCALE: 4:1	DIMENSION UNITS: mm SCALE: 4:1	PRODUCT CUSTOMER DRAWING T-CONNECTOR EMI CAGES W/HEAT SINK
DOCUMENT NUMBER: 1726042100 DOC TYPE: PSD DOC PART: ASY SHEET NUMBER: 1 OF 5			

MEZZANINE CARD CONFIGURATION

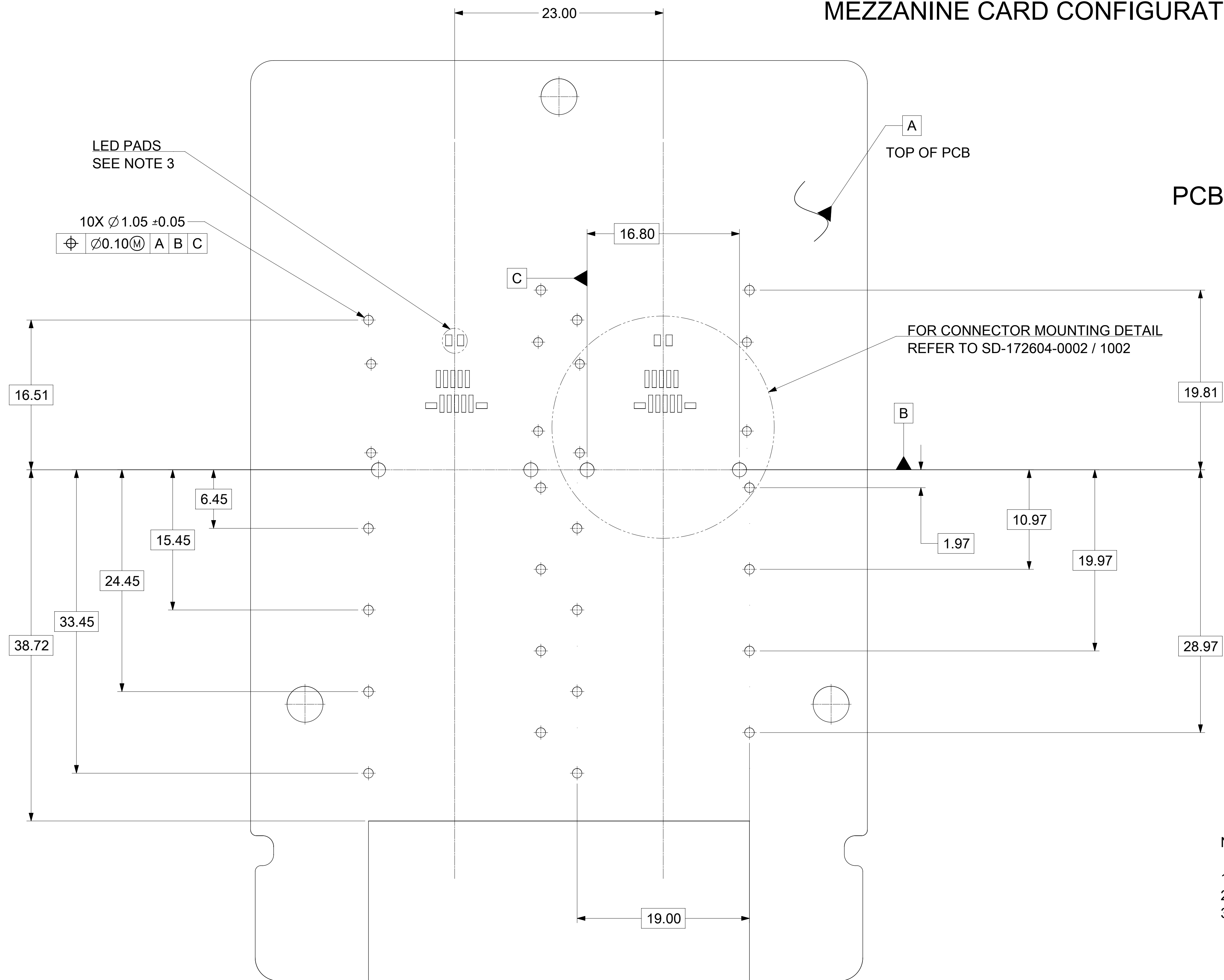

PCB HOLE LAYOUT FOR PRESS-IN CAGE

SINGLE SIDED APPLICATION HOLE PATTERN SHOWN

NOTES:

- 1) MINIMUM PCB THICKNESS: 1.83 mm FOR DOUBLE SIDED (BELLY-TO-BELLY) APPLICATIONS.
- 2) MINIMUM PCB THICKNESS: 1.57 mm FOR SINGLE SIDED APPLICATIONS.
- 3) RECOMMENDED LED PACKAGE: 1608/0603 0.4mm HIGH MAX.

THIS DRAWING CONTAINS INFORMATION THAT IS PROPRIETARY TO MOLEX ELECTRONIC TECHNOLOGIES, LLC AND SHOULD NOT BE USED WITHOUT WRITTEN PERMISSION

SEE P/N TABLE EC NO: 169860 DRWN: PGSHETTY CHKD: DSUN15 REV APPR: RCHEN08	2017/12/20	GENERAL TOLERANCES (UNLESS SPECIFIED)	DIMENSION UNITS	SCALE	molex T-CONNECTOR EMI CAGES W/HEAT SINK PRODUCT CUSTOMER DRAWING	
	2017/12/21		mm	4:1		
	2017/12/21		ANGULAR TOL ± 0.5 °	DRWN BY		DATE
	4 PLACES ±		PGSHETTY	2017/12/20		
	3 PLACES ±		CHKD BY	DATE		
	2 PLACES ± 0.13		DSUN15	2017/12/21		
1 PLACE ± 0.25	APPR BY	DATE	SERIES MATERIAL NUMBER CUSTOMER			
0 PLACES ±	RCHEN08	2017/12/21	172604 1726042100			
DRAFT WHERE APPLICABLE MUST REMAIN WITHIN DIMENSIONS	DRAWING SIZE	THIRD ANGLE PROJECTION	DOCUMENT NUMBER DOC TYPE DOC PART SHEET NUMBER			
	D		1726042100 PSD ASY 2 OF 5			

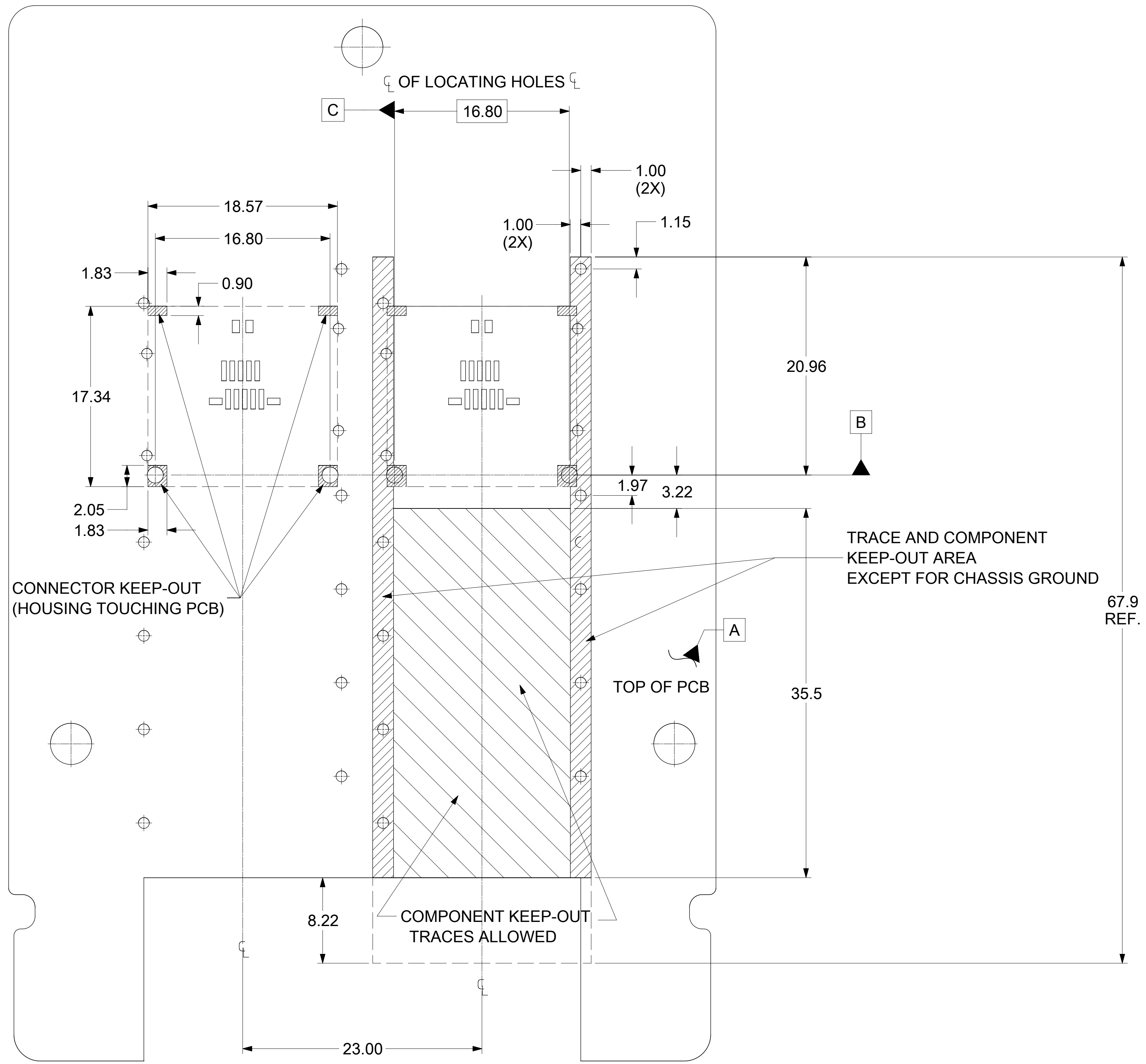

CONNECTOR AND CAGE KEEP-OUT ZONES

THIS DRAWING CONTAINS INFORMATION THAT IS PROPRIETARY TO MOLEX ELECTRONIC TECHNOLOGIES, LLC AND SHOULD NOT BE USED WITHOUT WRITTEN PERMISSION

SEE P/N TABLE	EC NO: 169860	2017/12/20	GENERAL TOLERANCES (UNLESS SPECIFIED)	DIMENSION UNITS	SCALE			
	DRWN: PGSHETTY	2017/12/21		mm	4:1			
	CHKD: DSUN15	2017/12/21		ANGULAR TOL ± 0.5 °	DRWN BY		DATE	
	REV/ APPR: RCHEN08	2017/12/21		4 PLACES ±	PGSHETTY		2017/12/20	
				3 PLACES ±	CHKD BY		DATE	
				2 PLACES ± 0.13	DSUN15		2017/12/21	
		1 PLACE ± 0.25	APPR BY	DATE				
		0 PLACES ±	RCHEN08	2017/12/21				
		DRAFT WHERE APPLICABLE MUST REMAIN WITHIN DIMENSIONS	DRAWING SIZE	THIRD ANGLE PROJECTION	SERIES	MATERIAL NUMBER	CUSTOMER	
			D		172604	1726042100		
					DOCUMENT NUMBER	DOC TYPE	DOC PART	SHEET NUMBER
					1726042100	PSD	ASY	3 OF 5

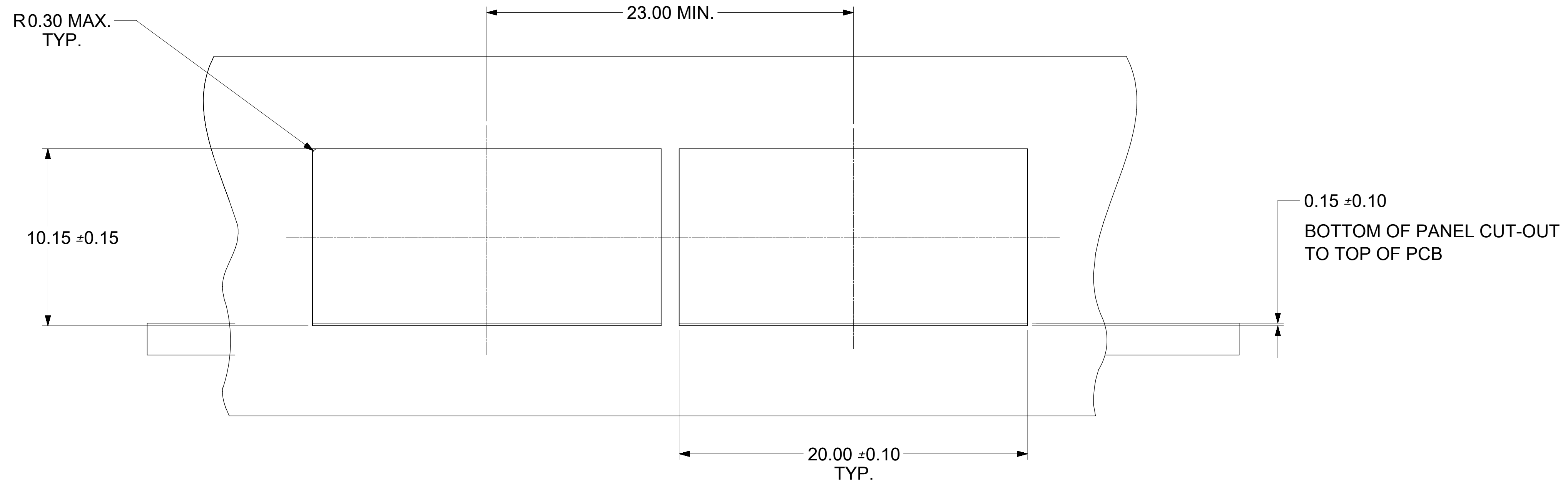

PANEL CUT-OUT FOR SINGLE SIDED MOUNTING

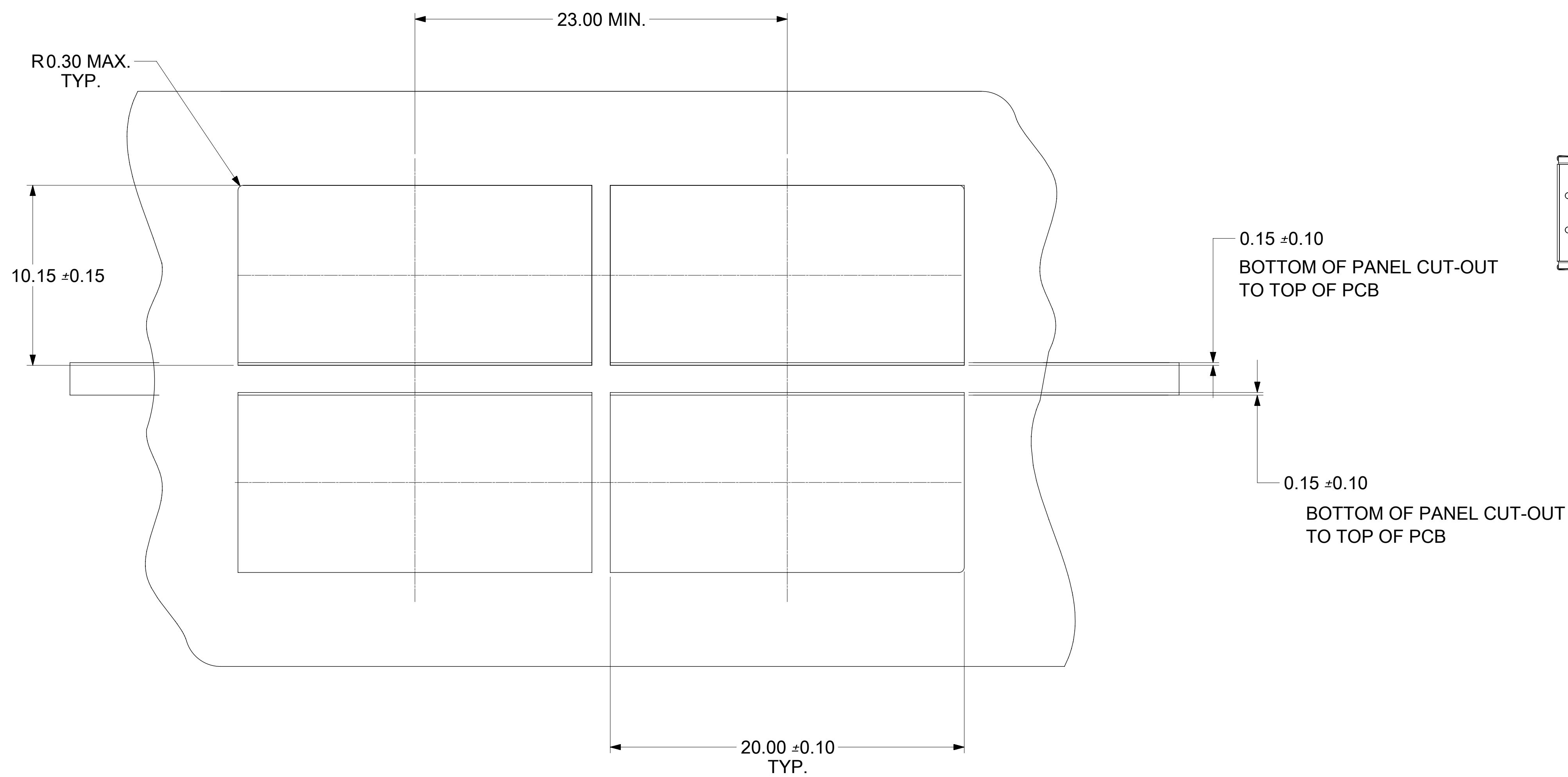

PANEL CUT-OUT FOR BELLY-TO-BELLY MOUNTING

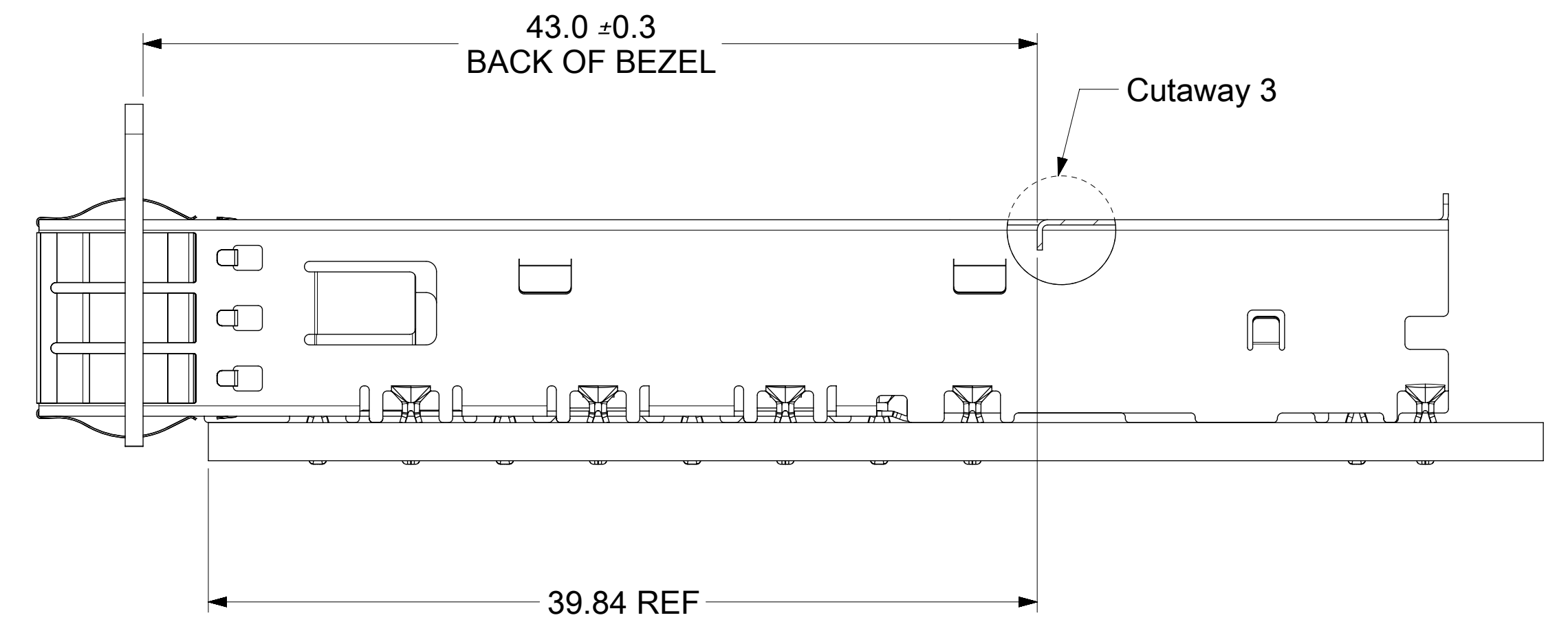

THIS DRAWING CONTAINS INFORMATION THAT IS PROPRIETARY TO MOLEX ELECTRONIC TECHNOLOGIES, LLC AND SHOULD NOT BE USED WITHOUT WRITTEN PERMISSION

SEE P/N TABLE EC NO: 169860 DRWN: PGSHETTY CHKD: DSUN15 REV APPR: RCHEN08	2017/12/20	GENERAL TOLERANCES (UNLESS SPECIFIED)	DIMENSION UNITS	SCALE			
	2017/12/21		mm	6:1			
	2017/12/21		ANGULAR TOL ± 0.5 °	DRWN BY		DATE	
	4 PLACES ±		PGSHETTY	2017/12/20			
3 PLACES ±	CHKD BY	DATE	T-CONNECTOR EMI CAGES W/HEAT SINK				
2 PLACES ± 0.13	DSUN15	2017/12/21					
1 PLACE ± 0.25	APPR BY	DATE	PRODUCT CUSTOMER DRAWING				
0 PLACES ±	RCHEN08	2017/12/21	DRAWING SIZE	THIRD ANGLE PROJECTION	SERIES	MATERIAL NUMBER	CUSTOMER
DRAFT WHERE APPLICABLE MUST REMAIN WITHIN DIMENSIONS	D		172604		1726042100		
			DOCUMENT NUMBER	DOC TYPE	DOC PART	SHEET NUMBER	
			1726042100	PSD	ASY	4 OF 5	

REV	DATE	DESCRIPTION
A	2017/10/2	INITIAL RELEASED
B	2017/11/30	SHEET 1: D6: ADDED 2X1.59+/-0.20 AND 2X3.52+/-0.10
C	2017/12/20	SHEET 3 : J13 : CORRECTED TYPO TO REMOVE HOLE

THIS DRAWING CONTAINS INFORMATION THAT IS PROPRIETARY TO MOLEX ELECTRONIC TECHNOLOGIES, LLC AND SHOULD NOT BE USED WITHOUT WRITTEN PERMISSION

SEE P/N TABLE	EC NO: 169860	2017/12/20	GENERAL TOLERANCES (UNLESS SPECIFIED)	DIMENSION UNITS	SCALE	molex [®]	
	DRWN: PGSHETTY	2017/12/21		mm	1:1		
	CHKD: DSUN15	2017/12/21		ANGULAR TOL ± 0.5 °	DRWN BY		DATE
	REV APPR: RCHEN08	2017/12/21		4 PLACES ±	PGSHETTY		2017/12/20
				3 PLACES ±	CHKD BY		DATE
				2 PLACES ± 0.13	DSUN15		2017/12/21
				1 PLACE ± 0.25	APPR BY		DATE
				0 PLACES ±	RCHEN08		2017/12/21
				DRAFT WHERE APPLICABLE MUST REMAIN WITHIN DIMENSIONS	DRAWING SIZE		THIRD ANGLE PROJECTION
					D		
RELEASE STATUS	P1	RELEASE DATE	21.12.2017 09:48:43	SERIES	MATERIAL NUMBER	CUSTOMER	
				172604	1726042100		
				DOCUMENT NUMBER	DOC TYPE	DOC PART SHEET NUMBER	
				1726042100	PSD	ASY 5 OF 5	

molex[®]

T-CONNECTOR EMI CAGES
W/HEAT SINK

PRODUCT CUSTOMER DRAWING

SERIES MATERIAL NUMBER CUSTOMER

172604 1726042100

DOCUMENT NUMBER DOC TYPE DOC PART SHEET NUMBER

1726042100 PSD ASY 5 OF 5

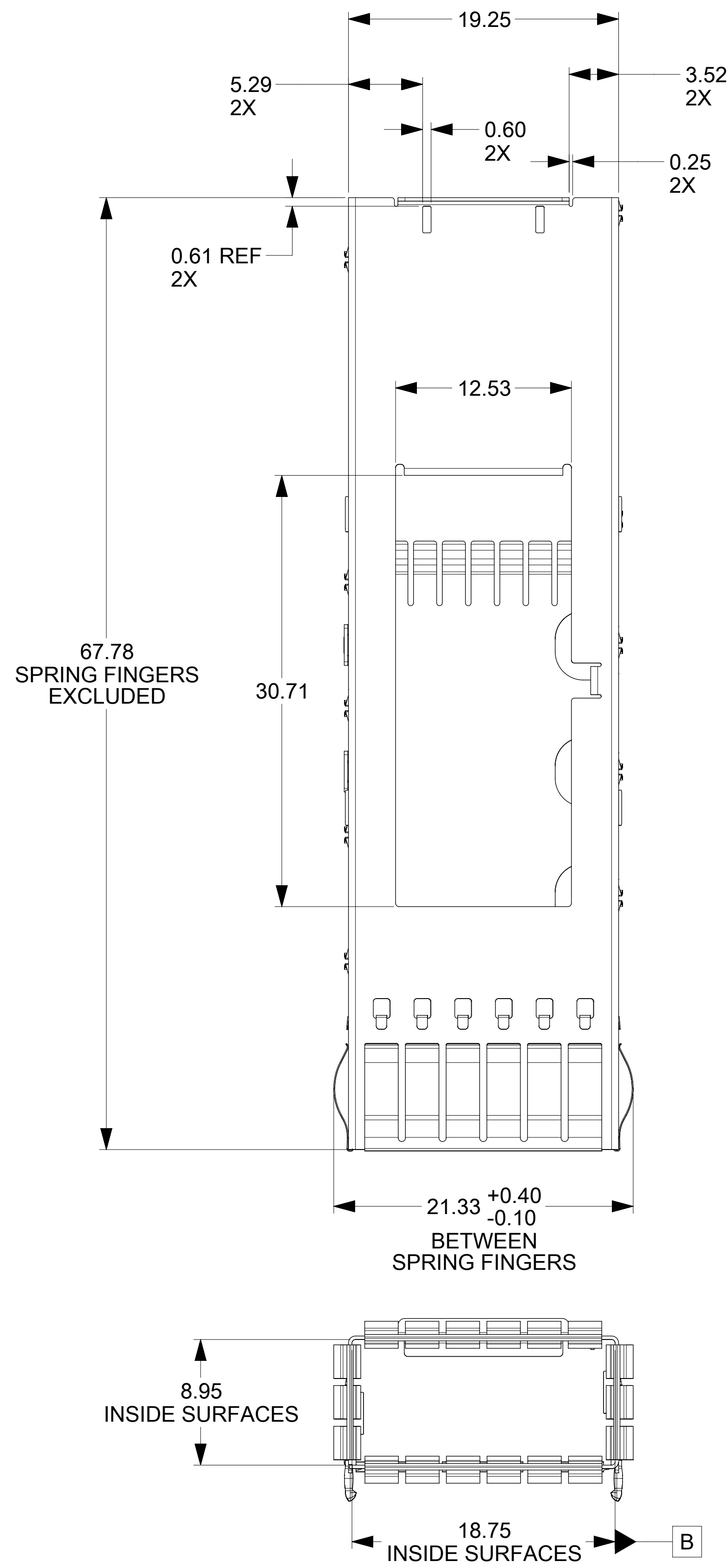

PART NUMBER	DESCRIPTION	HEAT SINK	HEAT SINK CLIP
172604-2100	CONNECTOR CAGE (ACCEPTS STANDARD HEAT SINK, STANDARD CLIP)	100013-0338	100013-0181
172604-2101	CONNECTOR CAGE (DOES NOT ACCEPT HEAT SINK OR CLIP)	N/A	N/A

* HEAT SINK AND CLIP SOLD SEPARATELY

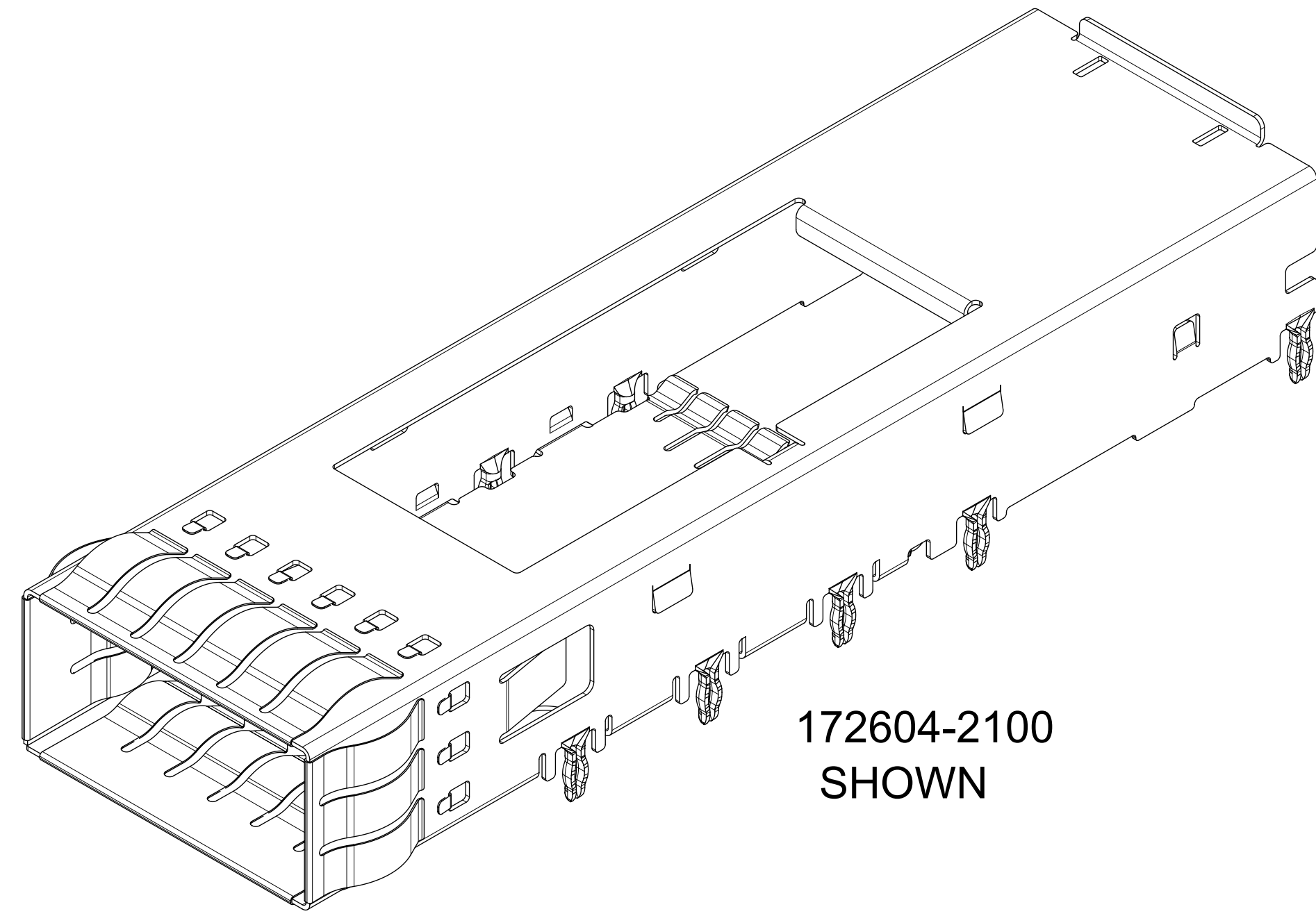

172604-2100 SHOWN

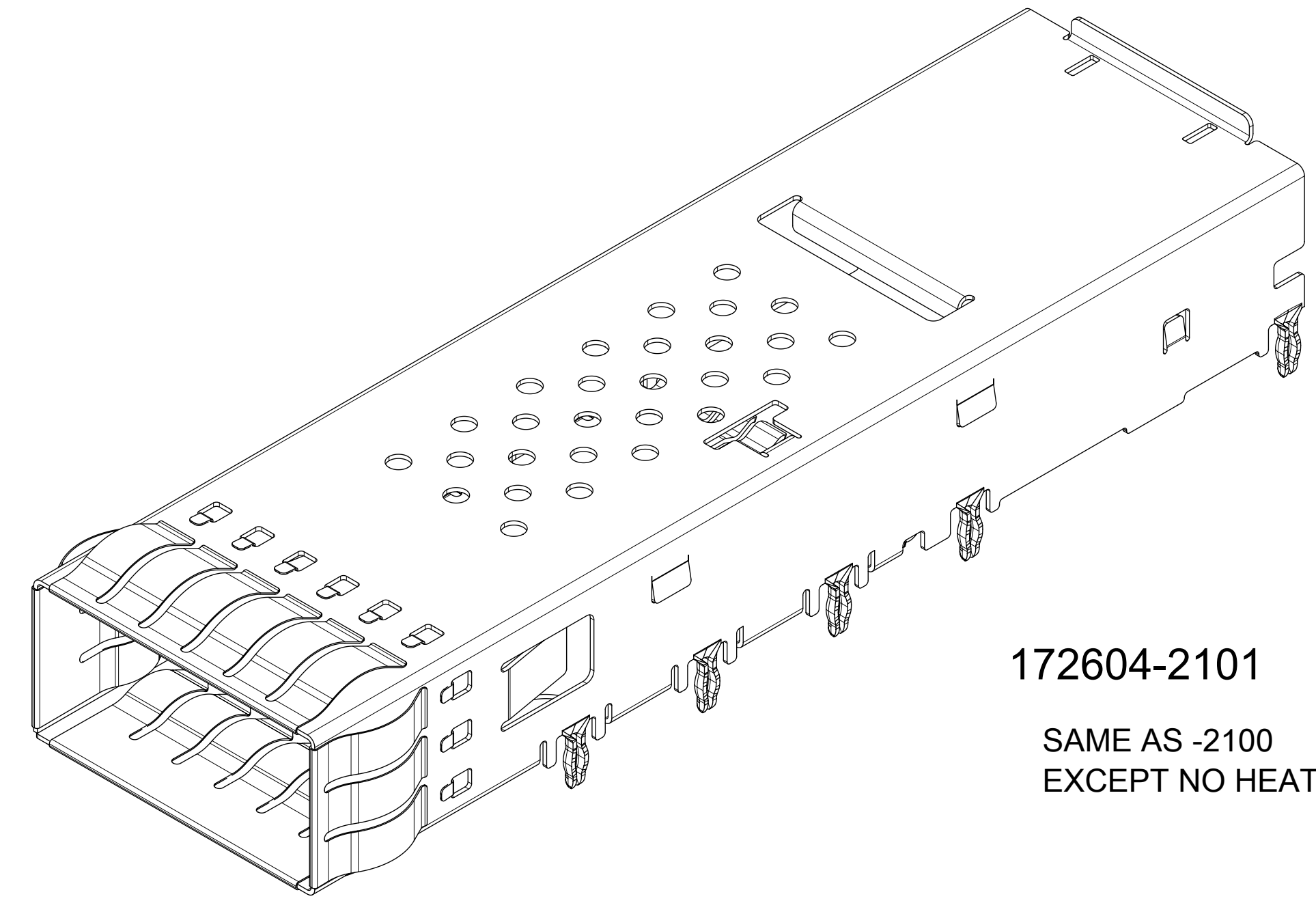

172604-2101
SAME AS -2100 EXCEPT NO HEAT SINK

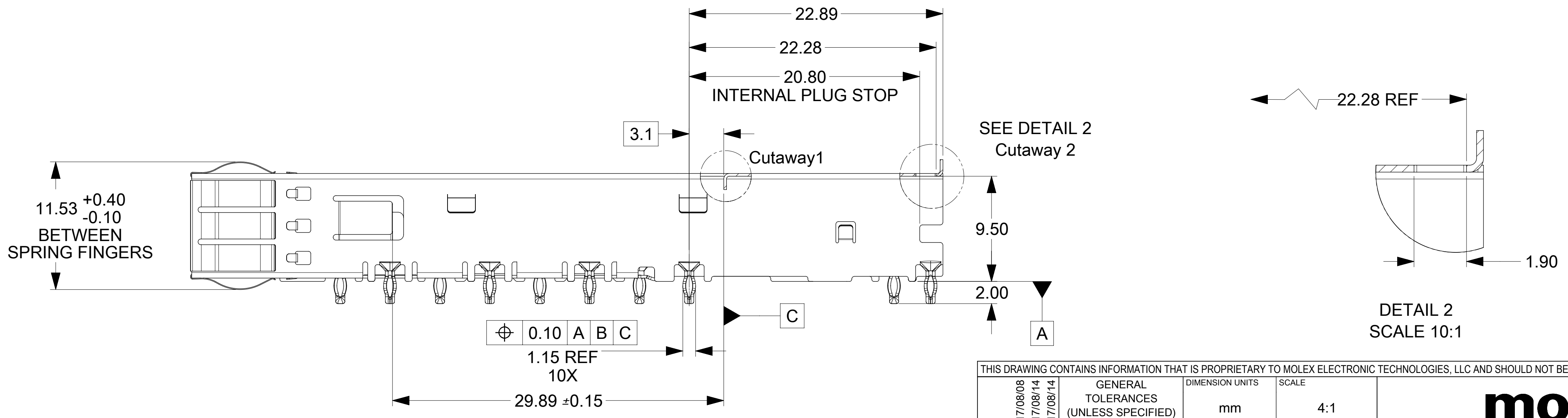

DETAIL 2 SCALE 10:1

- NOTES:
- MATERIALS:
 - CAGE: STAINLESS STEEL
 - EMI SPRINGS: COPPER ALLOY
 - FOR USE WITH IFT MODULE 172604-0002 AND -1002
 - COMPONENTS ARE RoHS COMPLIANT
 - PACKAGING: TRAY PACK

THIS DRAWING CONTAINS INFORMATION THAT IS PROPRIETARY TO MOLEX ELECTRONIC TECHNOLOGIES, LLC AND SHOULD NOT BE USED WITHOUT WRITTEN PERMISSION

MIGRATED TO INXECTR EC NO: 120648 DRWN: ABN CHKD: MCAIN REV APPR: SMILLER	2017/08/08	GENERAL TOLERANCES (UNLESS SPECIFIED)	DIMENSION UNITS	SCALE	
	2017/08/14	ANGULAR TOL ± 0.5 °	mm	4:1	
	2017/08/14	4 PLACES ±	DRWN BY	DATE	
		3 PLACES ±	MWOLFE	2017/01/06	
		2 PLACES ± 0.13	CHKD BY	DATE	
	1 PLACE ± 0.25	MCAIN	2017/08/14		
	0 PLACES ±	APPR BY	DATE		
		SMILLER	2017/08/14		
		DRAFT WHERE APPLICABLE MUST REMAIN WITHIN DIMENSIONS	DRAWING SIZE	THIRD ANGLE PROJECTION	
			D		

PRODUCT CUSTOMER DRAWING		
SERIES	MATERIAL NUMBER	CUSTOMER
172604	172604-21**	GENERAL MARKET
DOCUMENT NUMBER	DOC TYPE	DOC PART SHEET NUMBER
SD-172604-2100	PSD	001 1 OF 4

MEZZANINE CARD CONFIGURATION

PCB HOLE LAYOUT FOR PRESS-IN CAGE

SINGLE SIDED APPLICATION HOLE PATTERN SHOWN

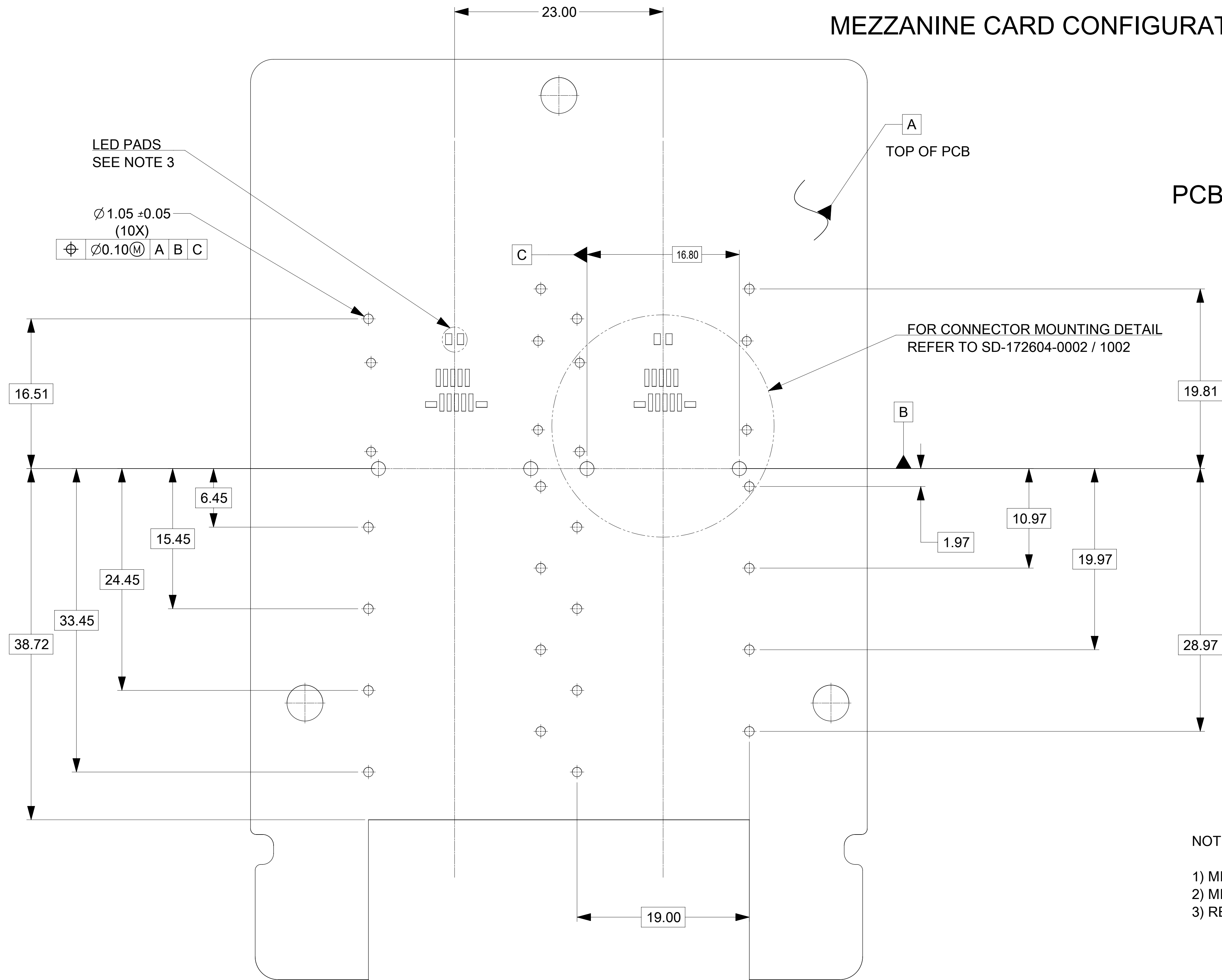

NOTES:

- 1) MINIMUM PCB THICKNESS: 1.83 mm / .072 in. FOR DOUBLE SIDED (BELLY-TO-BELLY) APPLICATIONS.
- 2) MINIMUM PCB THICKNESS: 1.57 mm / .063 in. FOR SINGLE SIDED APPLICATIONS.
- 3) RECOMMENDED LED PACKAGE: 1608/0603 0.4mm HIGH MAX.

THIS DRAWING CONTAINS INFORMATION THAT IS PROPRIETARY TO MOLEX ELECTRONIC TECHNOLOGIES, LLC AND SHOULD NOT BE USED WITHOUT WRITTEN PERMISSION											
MIGRATED TO INXECTR EC NO: 120648 DRWN: ABN CHKD: MCAIN REV APPR: SMILLER	2017/08/08	GENERAL TOLERANCES (UNLESS SPECIFIED)		DIMENSION UNITS	SCALE						
	2017/08/14	ANGULAR TOL ± 0.5 °		mm	4:1						
	2017/08/14	4 PLACES ±	DRWN BY	DATE							
			3 PLACES ±	MWOLFE	2017/01/06	IFT CONNECTOR EMI CAGES					
			2 PLACES ± 0.13	CHKD BY	DATE						
			1 PLACE ± 0.25	MCAIN	2017/08/14						
		0 PLACES ±	APPR BY	DATE	PRODUCT CUSTOMER DRAWING						
		DRAFT WHERE APPLICABLE MUST REMAIN WITHIN DIMENSIONS	SMILLER	2017/08/14	SERIES	MATERIAL NUMBER	CUSTOMER				
A			DRAWING SIZE	THIRD ANGLE PROJECTION	172604	172604-21**	GENERAL MARKET				
			D		DOCUMENT NUMBER	DOC TYPE	DOC PART	SHEET NUMBER			
					SD-172604-2100	PSD	001	2 OF 4			

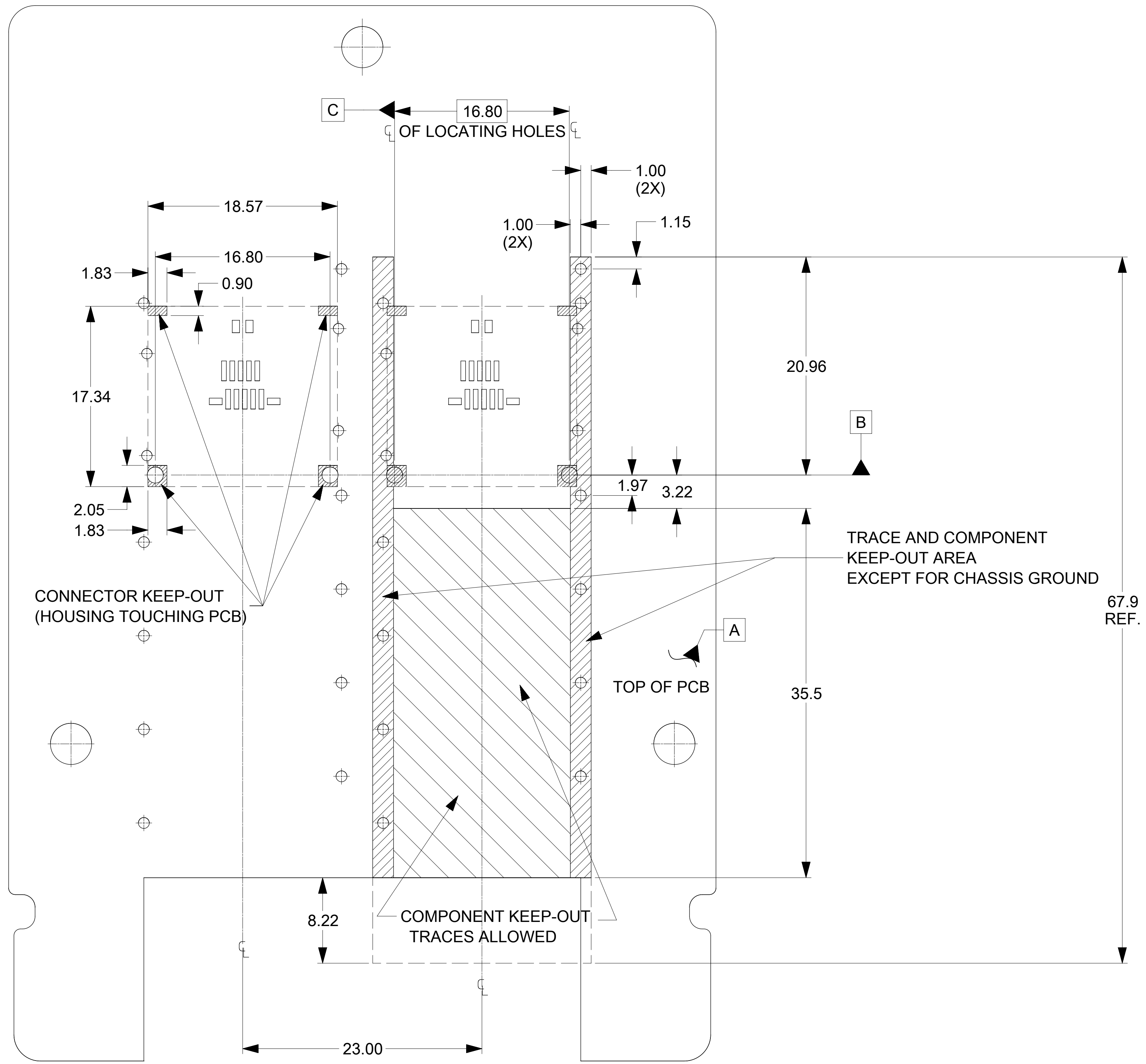

CONNECTOR AND CAGE KEEP-OUT ZONES

THIS DRAWING CONTAINS INFORMATION THAT IS PROPRIETARY TO MOLEX ELECTRONIC TECHNOLOGIES, LLC AND SHOULD NOT BE USED WITHOUT WRITTEN PERMISSION											
MIGRATED TO INXECTR EC NO: 120648 DRWN: ABN CHKD: MCAIN REV APPR: SMILLER	2017/08/08	GENERAL TOLERANCES (UNLESS SPECIFIED)		DIMENSION UNITS	SCALE	molex IFT CONNECTOR EMI CAGES					
	2017/08/14	ANGULAR TOL ± 0.5 °		mm	4:1						
	2017/08/14	4 PLACES ±	DRWN BY	DATE		PRODUCT CUSTOMER DRAWING					
		3 PLACES ±	MWOLFE	2017/01/06							
		2 PLACES ± 0.13	CHKD BY	DATE		SERIES MATERIAL NUMBER CUSTOMER					
		1 PLACE ± 0.25	MCAIN	2017/08/14							
	0 PLACES ±	APPR BY	DATE		DOCUMENT NUMBER DOC TYPE DOC PART SHEET NUMBER						
	DRAFT WHERE APPLICABLE MUST REMAIN WITHIN DIMENSIONS	SMILLER	2017/08/14								
A	D	THIRD ANGLE PROJECTION		172604	172604-21**	GENERAL MARKET					
				SD-172604-2100	PSD	001	3 OF 4				