

THIS DRAWING IS UNPUBLISHED. RELEASED FOR PUBLICATION 20  
 © COPYRIGHT 20 BY - ALL RIGHTS RESERVED.

REVISIONS				
P	LTR	DESCRIPTION	DATE	APVD
E		REV PER ECO 16-009873	7-1-16	CT DM

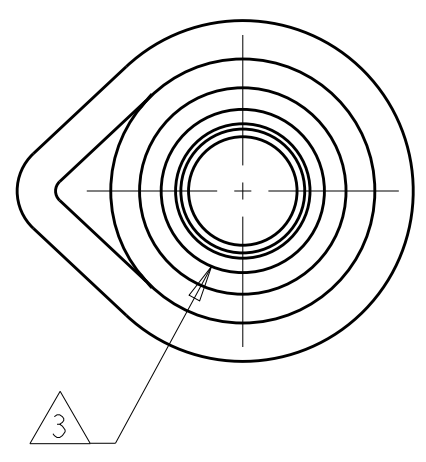
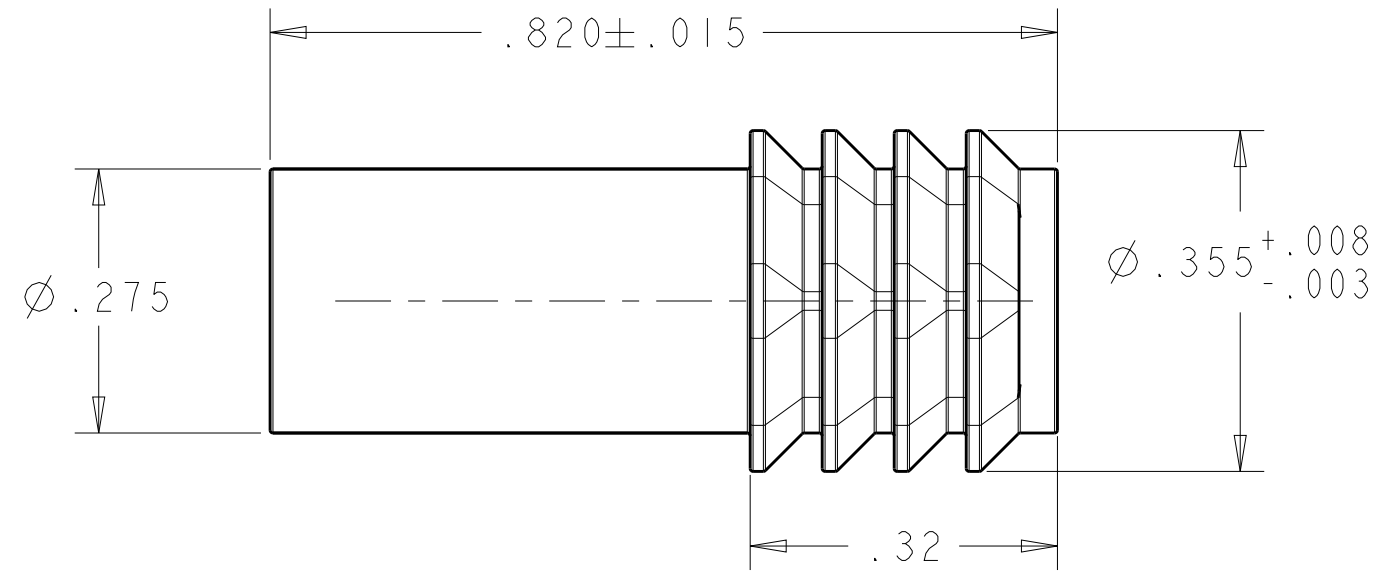
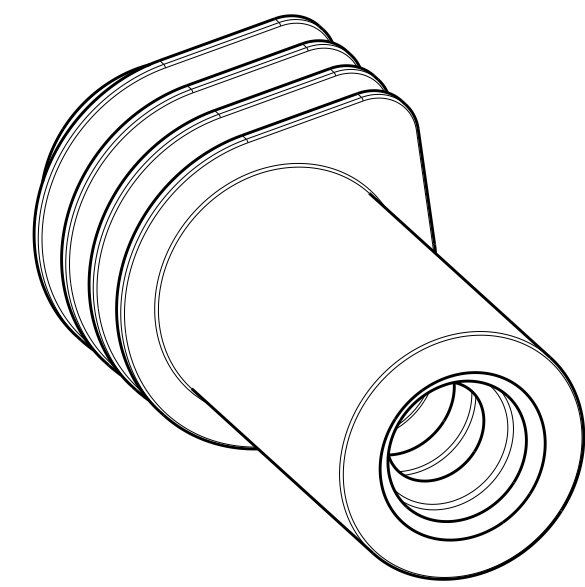
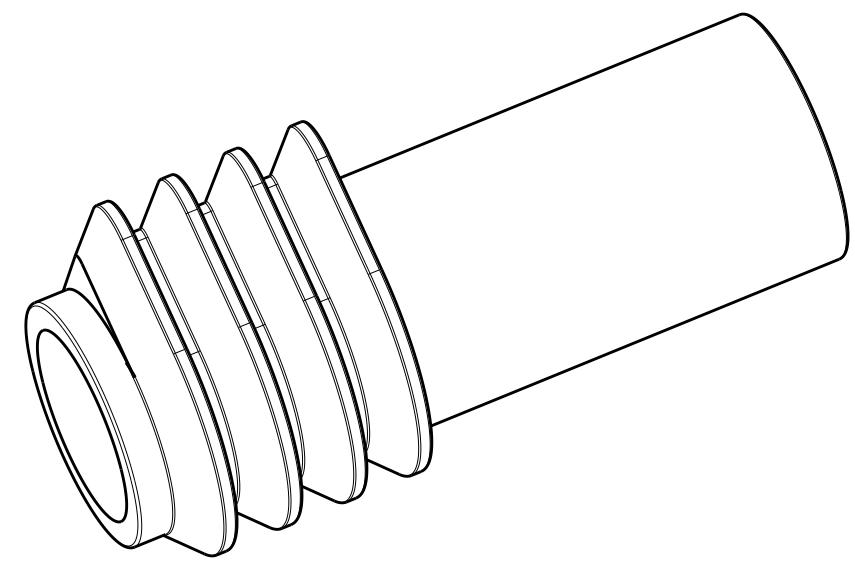

	1	△5	1811481-5
OBSOLETE	500	WIRE SEAL FOR QUAD CABLE	1811481-4
OBSOLETE	100	WIRE SEAL FOR QUAD CABLE	1811481-3
OBSOLETE	10	WIRE SEAL FOR QUAD CABLE	1811481-2
	-	-	1811481-1
	△4	PACKAGE QTY	DESCRIPTION PART NUMBER

- △1 MATERIAL: SELF LUBRICATING SILICONE PER ASTM D2000
- 2. COLOR: BLUE
- △3 INSIDE DIAMETER TO SEAL OFF ON .145-.175 INCH OUTSIDE DIAMETER CABLE
- △4 INDIVIDUAL SEAL, PN 1811481-1 PACKAGED IN POLY BAGS IN QUANTITY PER TABLE.
- △5 PACKAGE ONE PER BAG AND MARK WITH BACS45E1, TE CONNNECTIVITY, 00779, DATE CODE AND DO NOT REMOVE FROM PACKAGE UNTIL READY FOR USE. (WHEN INSPECTION REQUIRED, REPACKAGE AND RESEAL).

THIS DRAWING IS A CONTROLLED DOCUMENT.

DIMENSIONS: IN	TOLERANCES UNLESS OTHERWISE SPECIFIED: 0 PLC ± 1 PLC ± 2 PLC ±.01 3 PLC ±.005 4 PLC ± ANGLES ± FINISH	DWN 03JAN2005 Brent D. Yohn CHK 03JAN2005 R.P. WALTER APVD 03JAN2005 R.P. WALTER	TE Connectivity	
MATERIAL - △1		PRODUCT SPEC - APPLICATION SPEC -	NAME BOOT, SEAL, WIRE, QUADRA	
		WEIGHT -	SIZE A200779	CAGE CODE C-1811481
		CUSTOMER DRAWING	SCALE 5:1	SHEET OF 1 1

RESTRICTED TO  
REV E