

| LOC | | DIST | | REVISONS | | | |
|-----|-----|---------------------------|-----------|----------|------|--|--|
| P | LTN | DESCRIPTION | DATE | DWN | APVD | | |
| B2 | | REVISED PER ECO-11-004835 | 11MAR2011 | RK | HMR | | |
| B3 | | REVISED PER ECO-19-002570 | 26DEC2018 | JY | SH | | |
| B4 | | REVISED PER ECO-20-004397 | 26MAR2020 | TX | DZ | | |

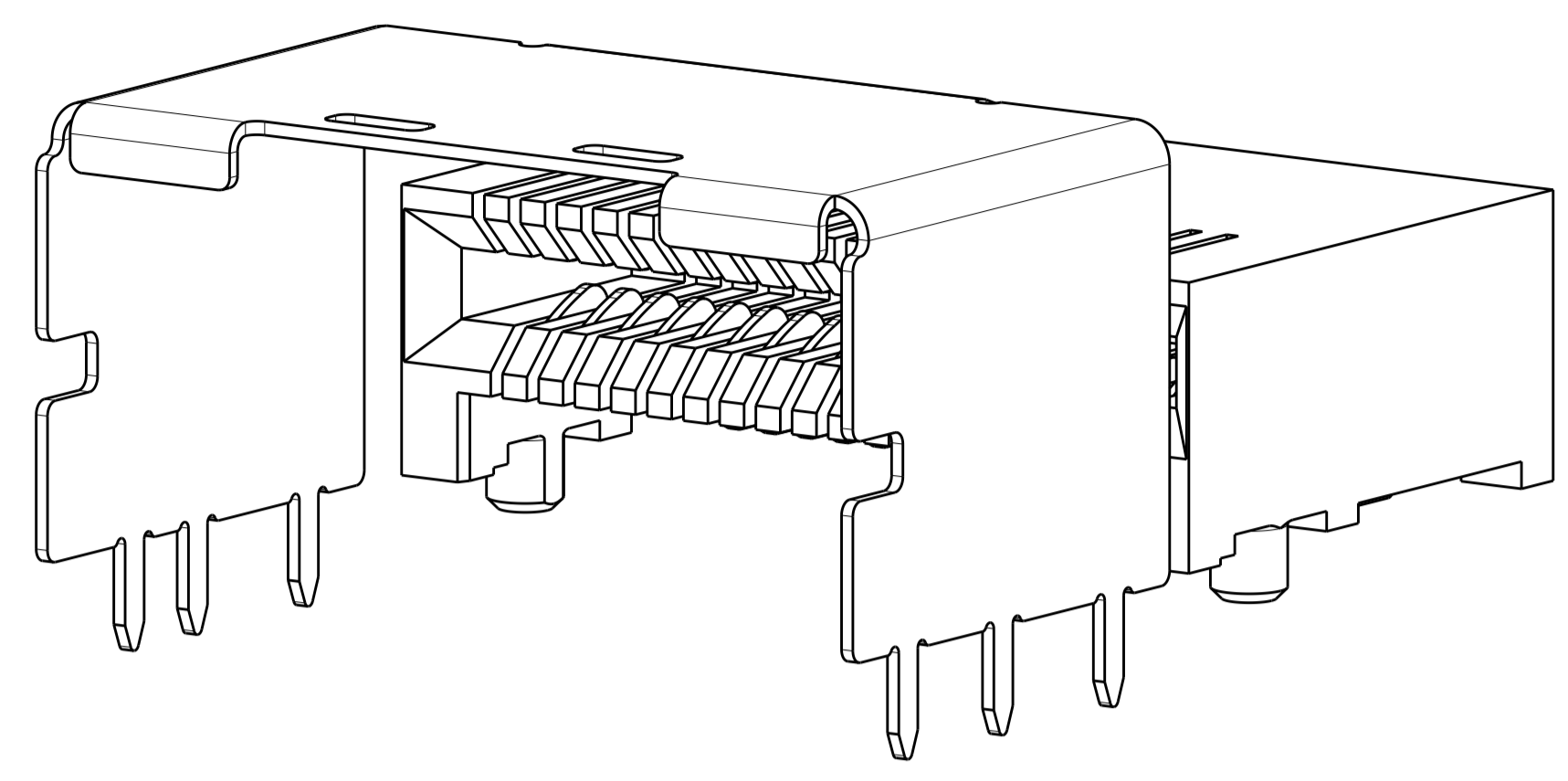

1888019-2
 SHOWN WITHOUT PICK AND PLACE DEVICE
 SCALE 8:1

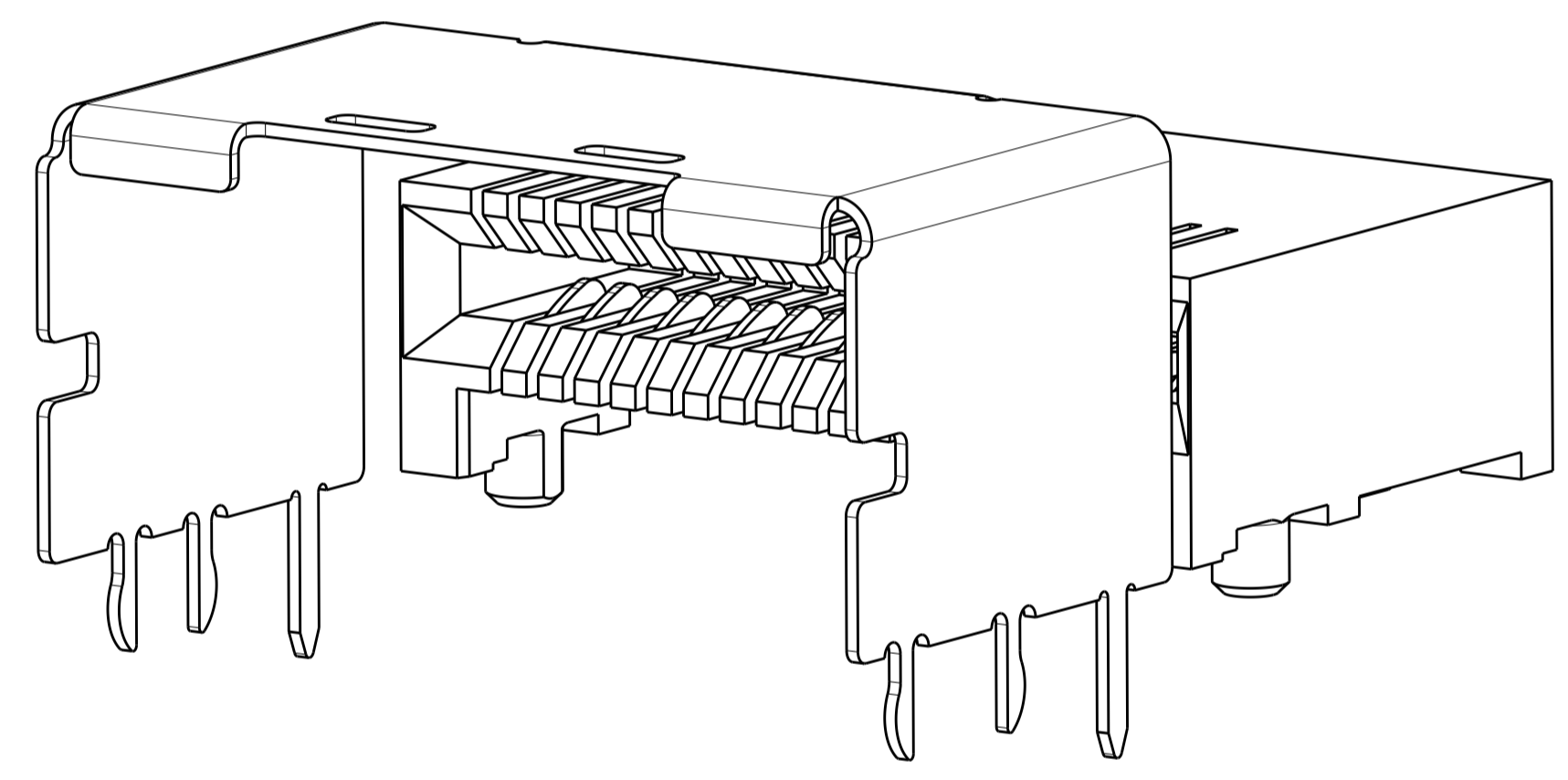

1888019-4
 SHOWN WITHOUT PICK AND PLACE DEVICE
 SCALE 8:1

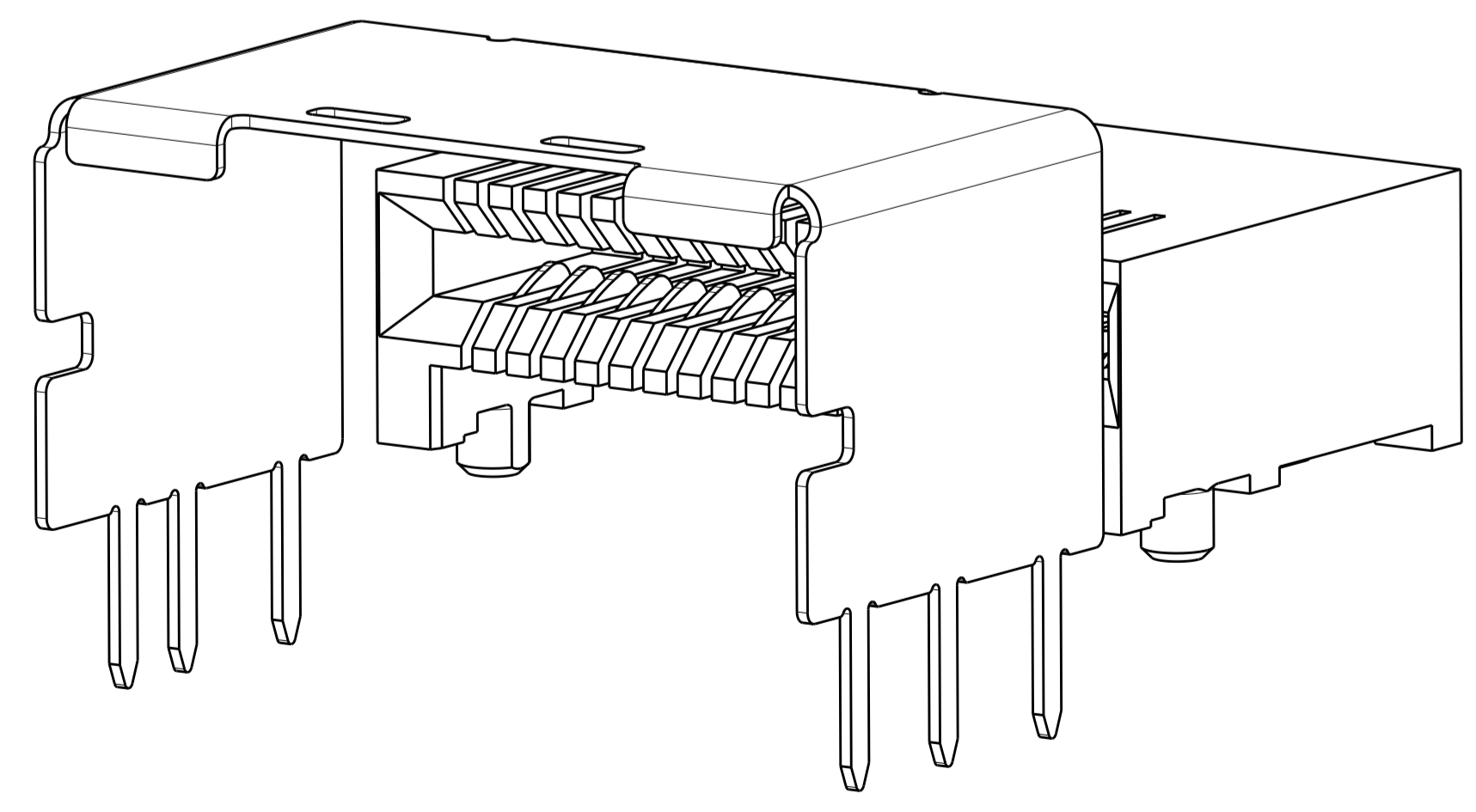

1888019-8
 SHOWN WITHOUT PICK AND PLACE DEVICE
 SCALE 8:1

- ① MATERIAL: LCP, BLACK, UL94 V0.
- ② MATERIAL: PHOSPHOR BRONZE PER ASTM B 103.
- ③ FINISH: 0.76µm MIN GOLD PLATE PER ASTM B 488, APPLIES TO INTERFACE AREA AND 2.03µm MIN TIN PLATE SOLDER TAILS, ALL OVER 3.81µm MIN NICKEL PLATE PER QQ-N-290.
- ④ MATERIAL: NICKEL-SILVER PER ASTM B 122.
- ⑤ DATUM AND BASIC DIMENSION ESTABLISHED BY CUSTOMER.
- 6. REFER TO CUSTOMER DRAWING 1761987 FOR CONNECTOR DETAILS.
- 7. PACKAGED IN TAPE AND REEL PER EIA-481.
- ⑧ FINISH: 0.38µm MIN GOLD PLATE PER ASTM B 488, APPLIES TO INTERFACE AREA AND 2.03µm MIN TIN PLATE SOLDER TAILS, ALL OVER 3.81µm MIN NICKEL PLATE PER QQ-N-290.
- ⑨ CUSTOMIZED PACKAGE SPEC FOR 1-1888019-3 AND 1-1888019-4

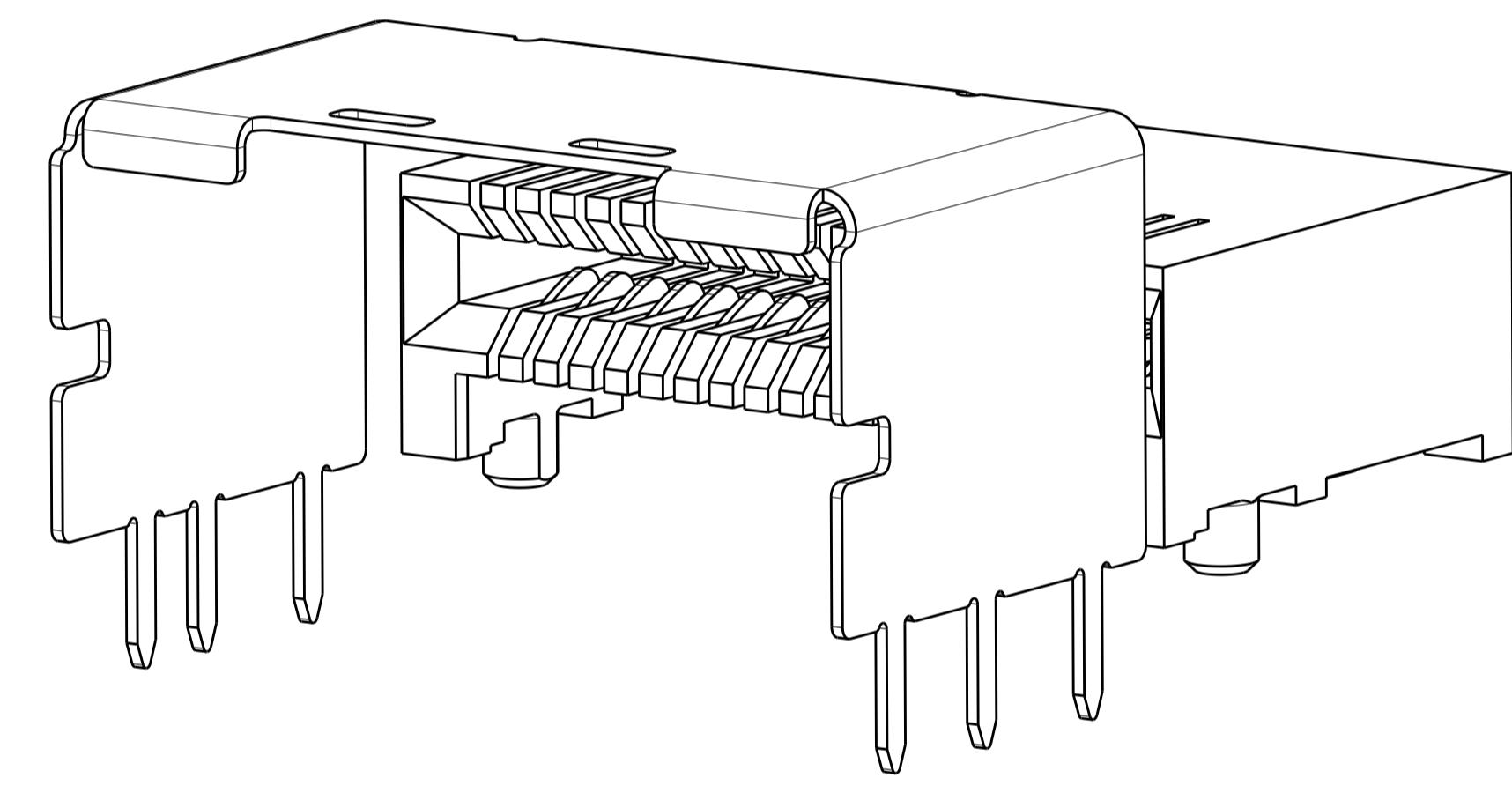

1888019-6, 1-1888019-3 AND 1-1888019-4
 SHOWN WITHOUT PICK AND PLACE DEVICE
 SCALE 8:1

| | | | | | | | | | |
|--------|------------|-----|------|----|----|----|-------|------|---------------|
| ⑧ | THRU HOLE | 3.5 | 17.8 | 16 | 16 | 36 | 18.05 | 36 | 1-1888019-2 |
| | THRU HOLE | 2.8 | 17.8 | 16 | 16 | 36 | 18.05 | 36 | 1-1888019-1 |
| | PRESS FIT | - | 17.8 | 16 | 16 | 36 | 18.05 | 36 | 1-1888019-0 |
| ③ | THRU HOLE | 2 | 17.8 | 16 | 16 | 36 | 18.05 | 36 | 1888019-9 |
| | THRU HOLE | 2.8 | 17.8 | 16 | 16 | 36 | 18.05 | 36 | 1-1888019-4 ⑨ |
| | THRU HOLE | 2.8 | 17.8 | 16 | 16 | 36 | 18.05 | 36 | 1-1888019-3 ⑨ |
| | THRU HOLE | 3.5 | 17.8 | 16 | 16 | 36 | 18.05 | 36 | 1888019-8 |
| | THRU HOLE | 2.8 | 17.8 | 16 | 16 | 36 | 18.05 | 36 | 1888019-6 |
| | PRESS FIT | - | 17.8 | 16 | 16 | 36 | 18.05 | 36 | 1888019-4 |
| | THRU HOLE | 2 | 17.8 | 16 | 16 | 36 | 18.05 | 36 | 1888019-2 |
| FINISH | SHELL TYPE | G | E | D | C | B | A | POSN | PART NUMBER |

THIS DRAWING IS A CONTROLLED DOCUMENT. DWN M.E. CONNER 18JUL2005
 CHK R.R. HENRY 18JUL2005
 APVD R.R. HENRY 18JUL2005

STE TE Connectivity

NAME: EVERCLEAR Mini-SAS RIGHT ANGLE INTERNAL RECEPTACLE ASSEMBLY WITH DUAL KEYED SHELL

PRODUCT SPEC: 108-2234
 APPLICATION SPEC: -

SIZE: A1 CAGE CODE: 100779 DRAWING NO: 1888019
 WEIGHT: -
 MATERIAL: SEE NOTES FINISH: SEE TABLE

CUSTOMER DRAWING SCALE: 8:1 SHEET 1 OF 4 REV: B4

| LOC | | DIST | | REVISIONS | | | |
|-----|----|------|-----|-------------|------|-----|------|
| GP | 00 | P | LTN | DESCRIPTION | DATE | DMN | APVD |
| | | - | | SEE SHEET 1 | | | |

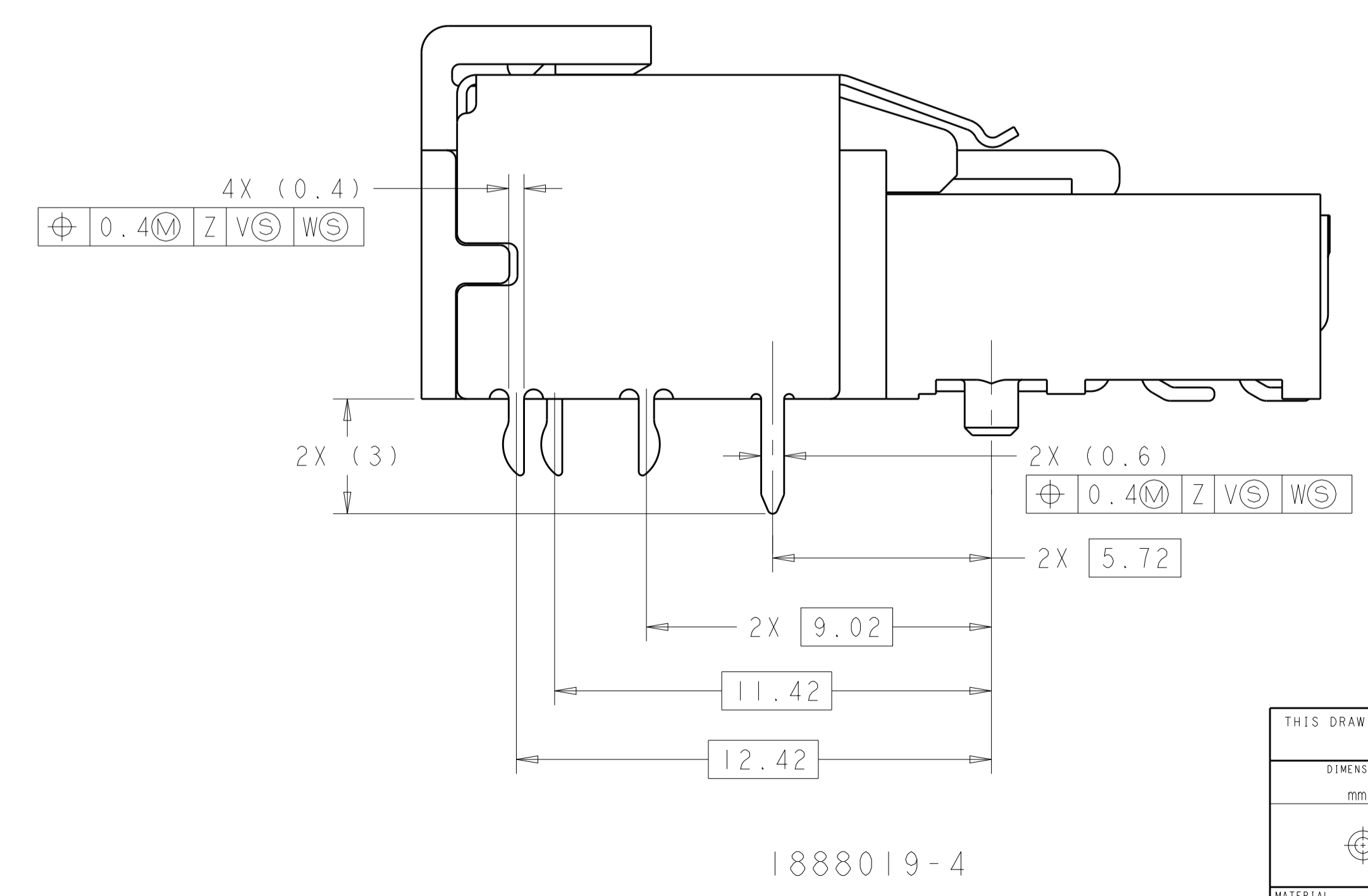
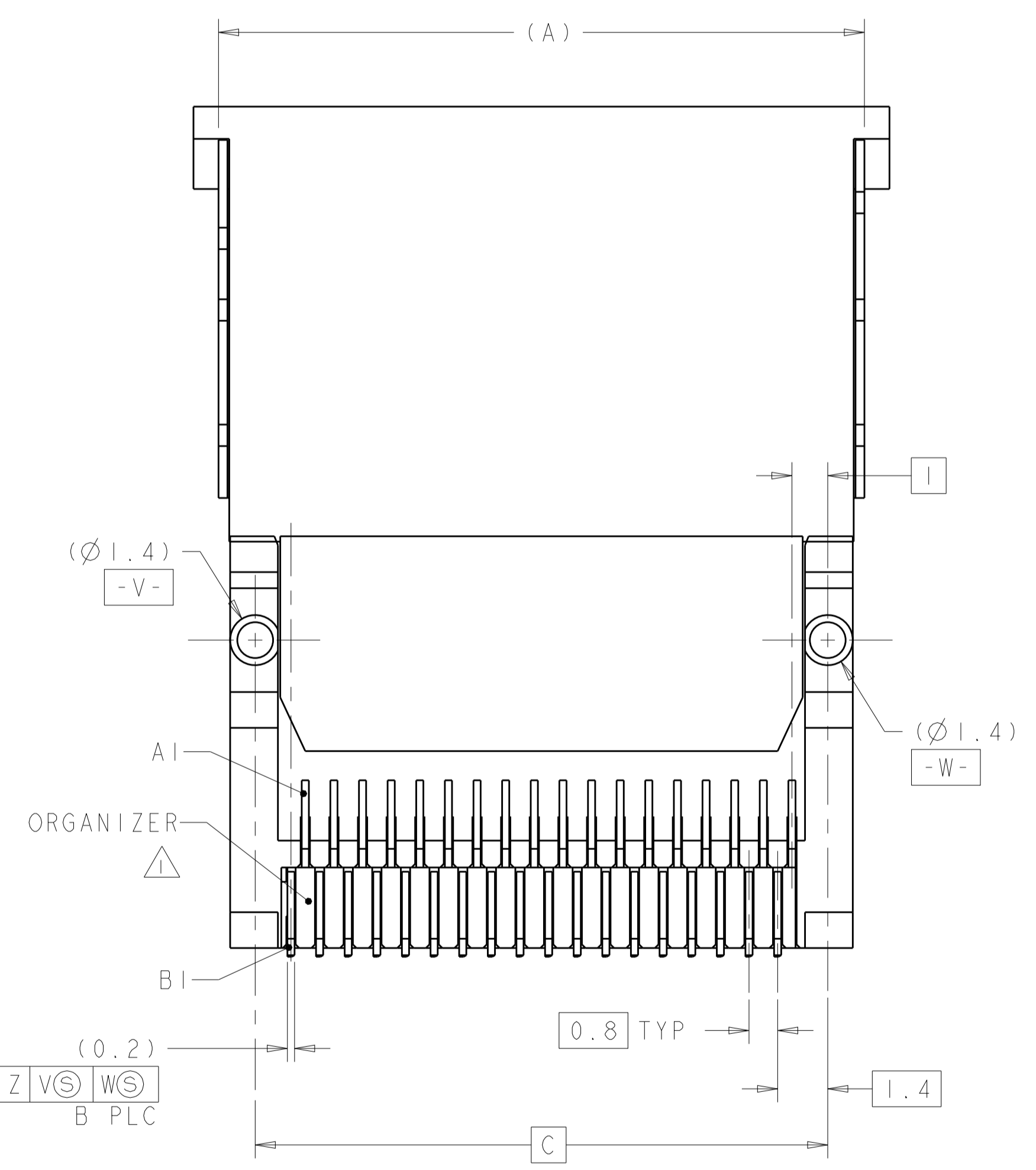
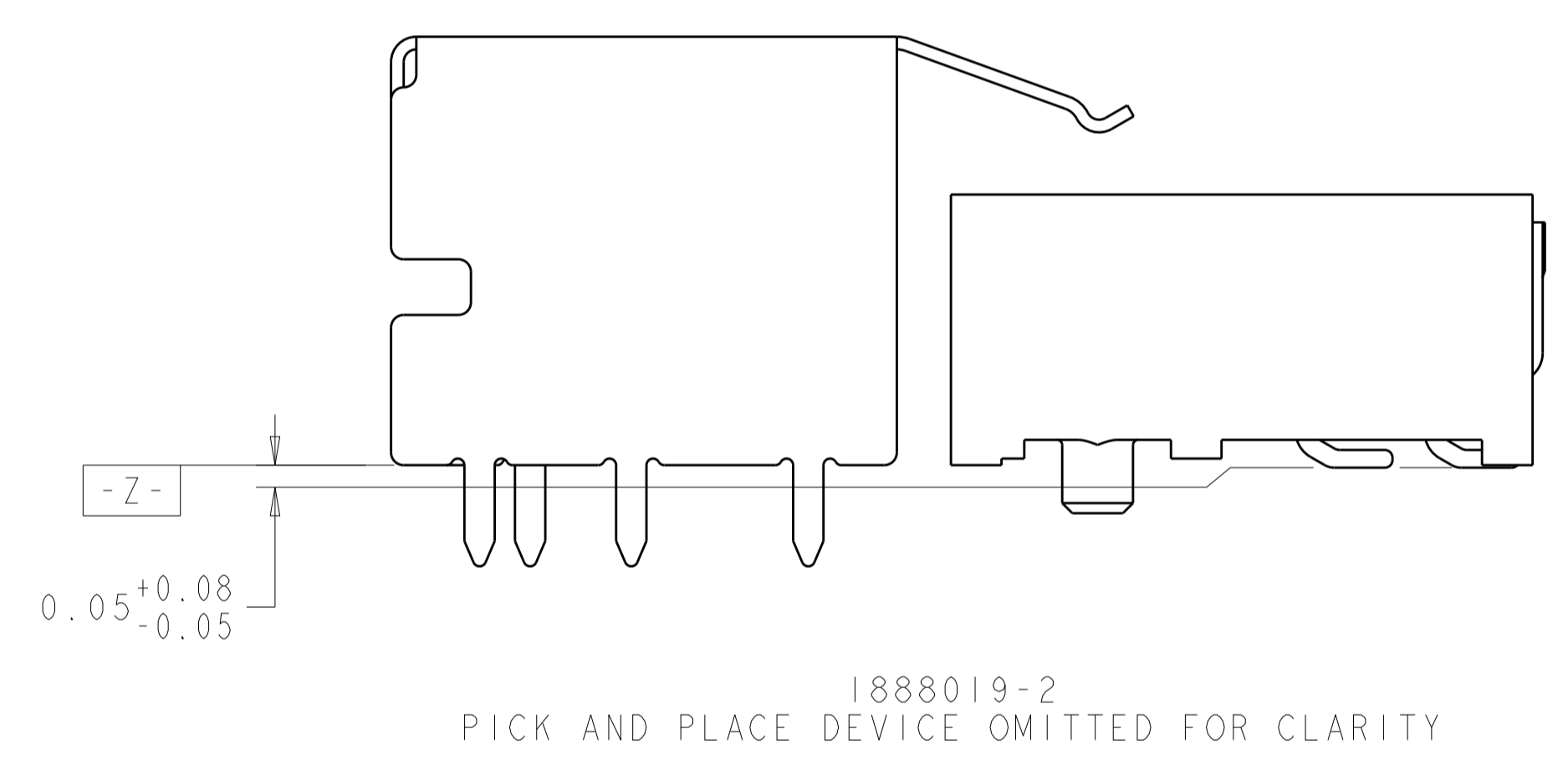
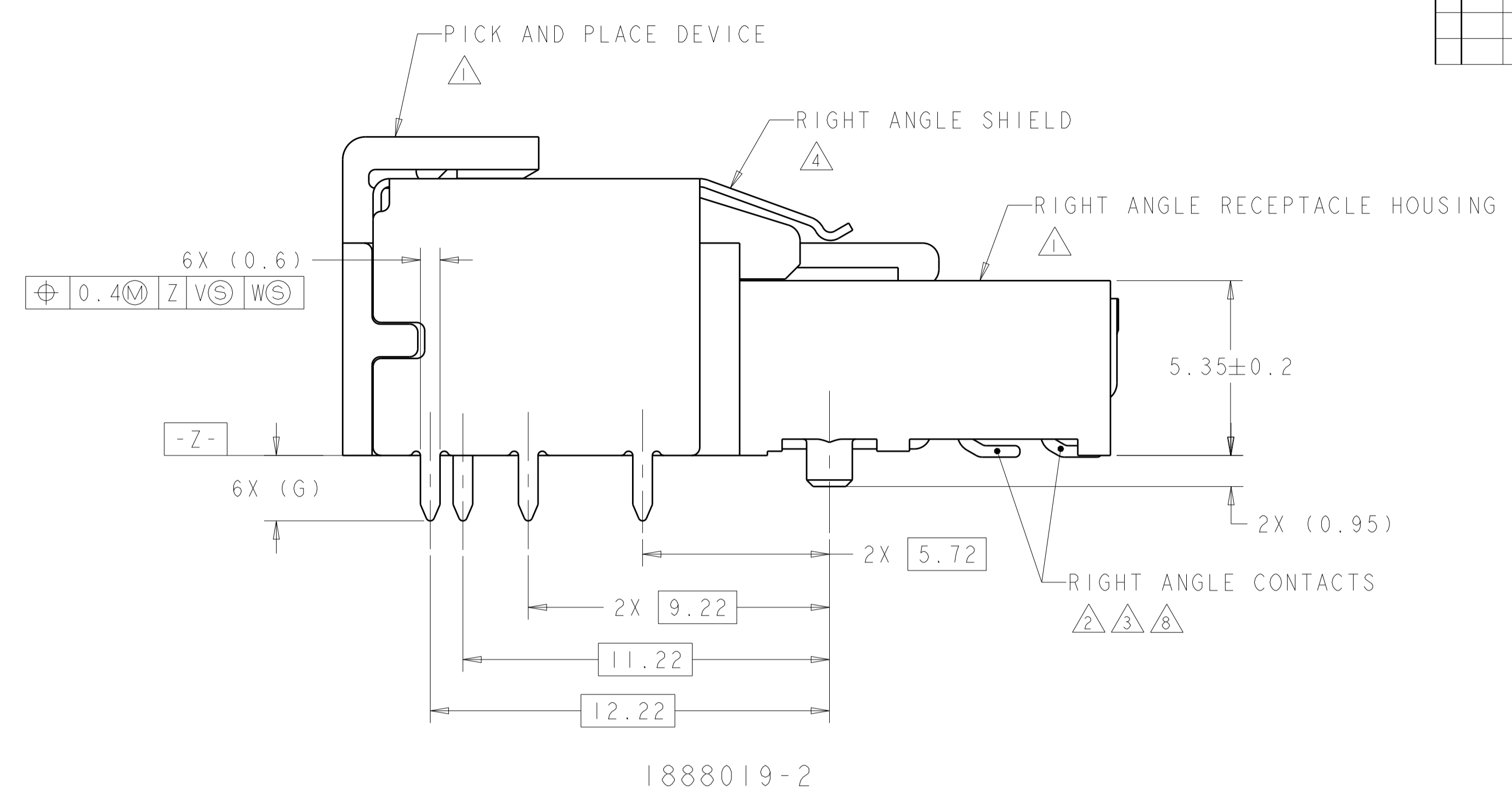
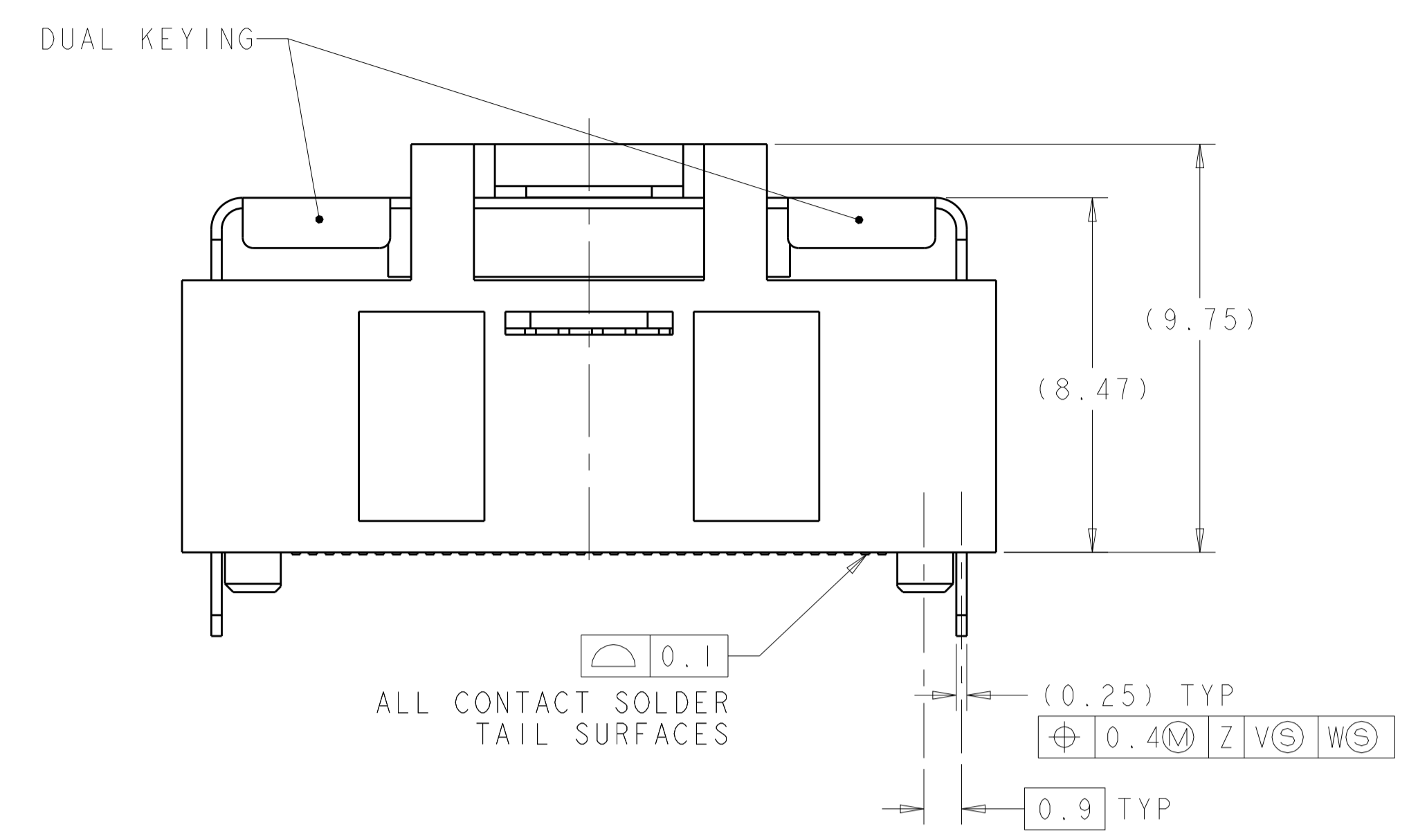

| | | | |
|--|------------------|---------------------------|---|
| THIS DRAWING IS A CONTROLLED DOCUMENT. | | DMN M.E. CONNER 18JUL2005 | TE Connectivity |
| DIMENSIONS: mm | | CHK R.R. HENRY 18JUL2005 | |
| TOLERANCES UNLESS OTHERWISE SPECIFIED: | | APVD R.R. HENRY 18JUL2005 | NAME |
| 0 PLC ± | 1 PLC ± | PRODUCT SPEC | EVERCLEAR Mini-SAS RIGHT ANGLE INTERNAL RECEPTACLE ASSEMBLY WITH DUAL KEYED SHELL |
| 2 PLC ± | 3 PLC ± | APPLICATION SPEC | SIZE CAGE CODE DRAWING NO RESTRICTED TO |
| 4 PLC ± | ANGLES ± | WEIGHT | A100779C=1888019 |
| MATERIAL SEE NOTES | FINISH SEE TABLE | CUSTOMER DRAWING | SCALE 8:1 SHEET 2 OF 4 REV B4 |

| LOC | | DIST | | REVISIONS | | | |
|-----|----|------|-----|-------------|------|-----|------|
| GP | 00 | P | LTN | DESCRIPTION | DATE | DMN | APVD |
| | | - | | SEE SHEET 1 | | | |

1-1888019-4 AS SHOWN

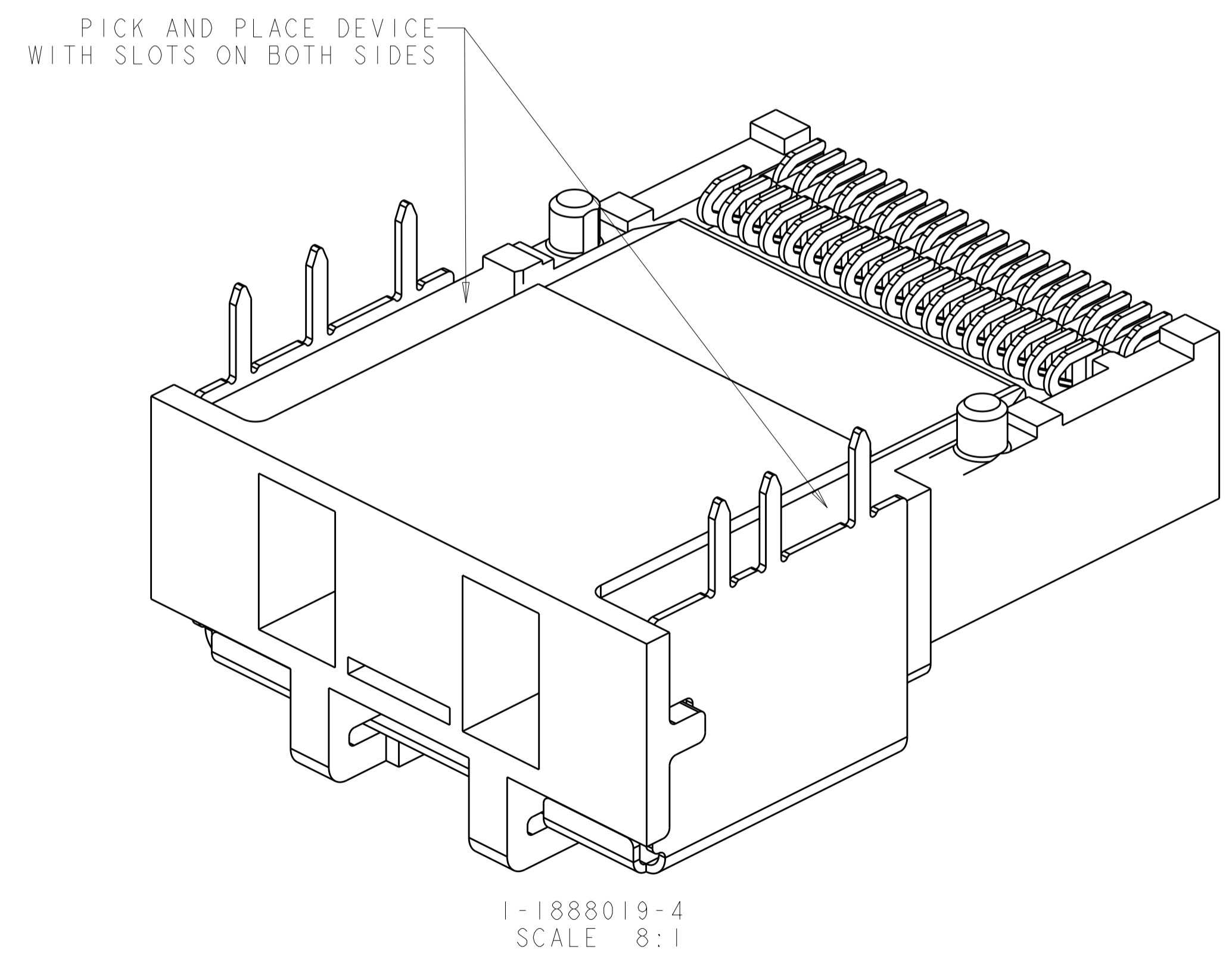
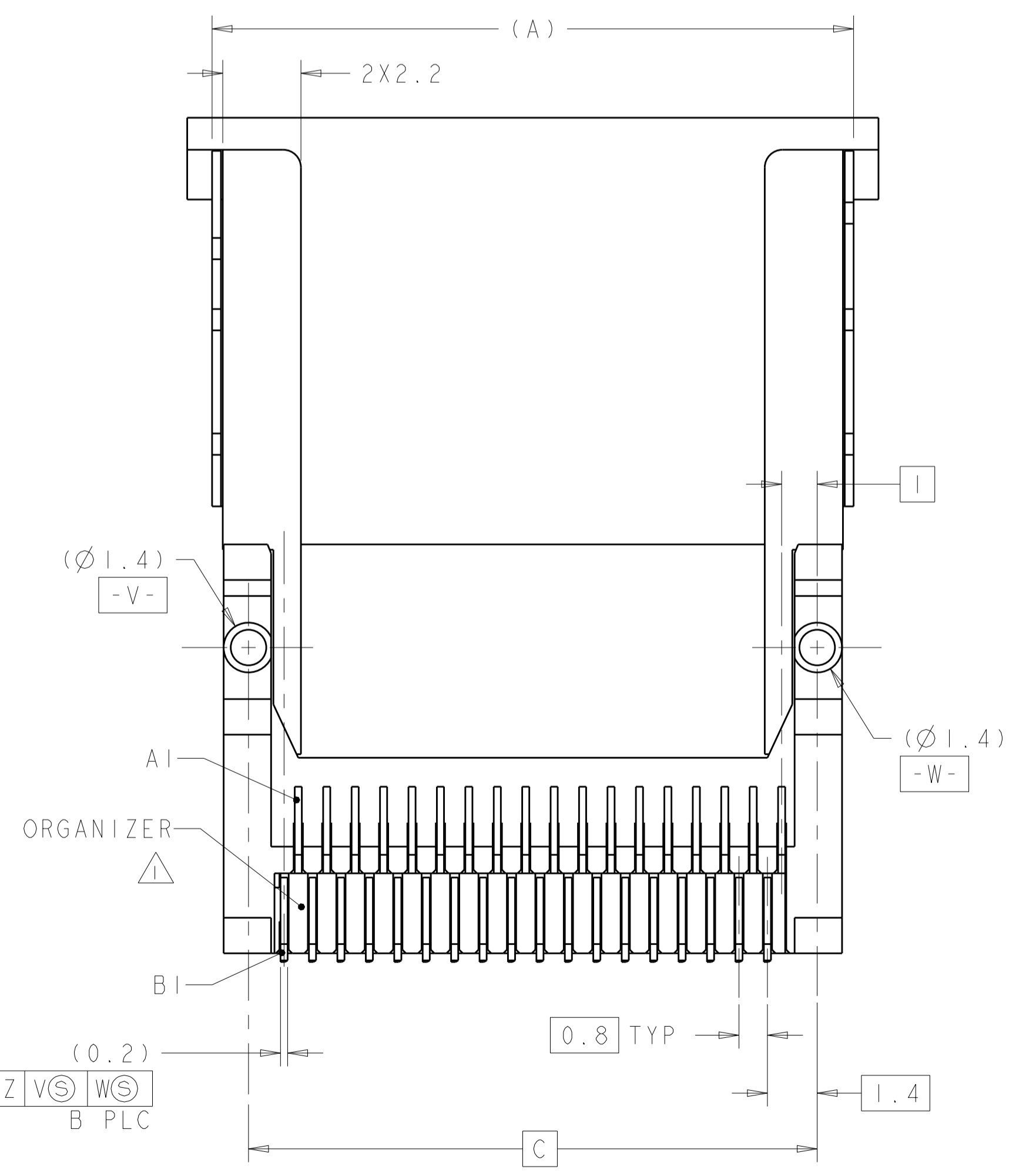
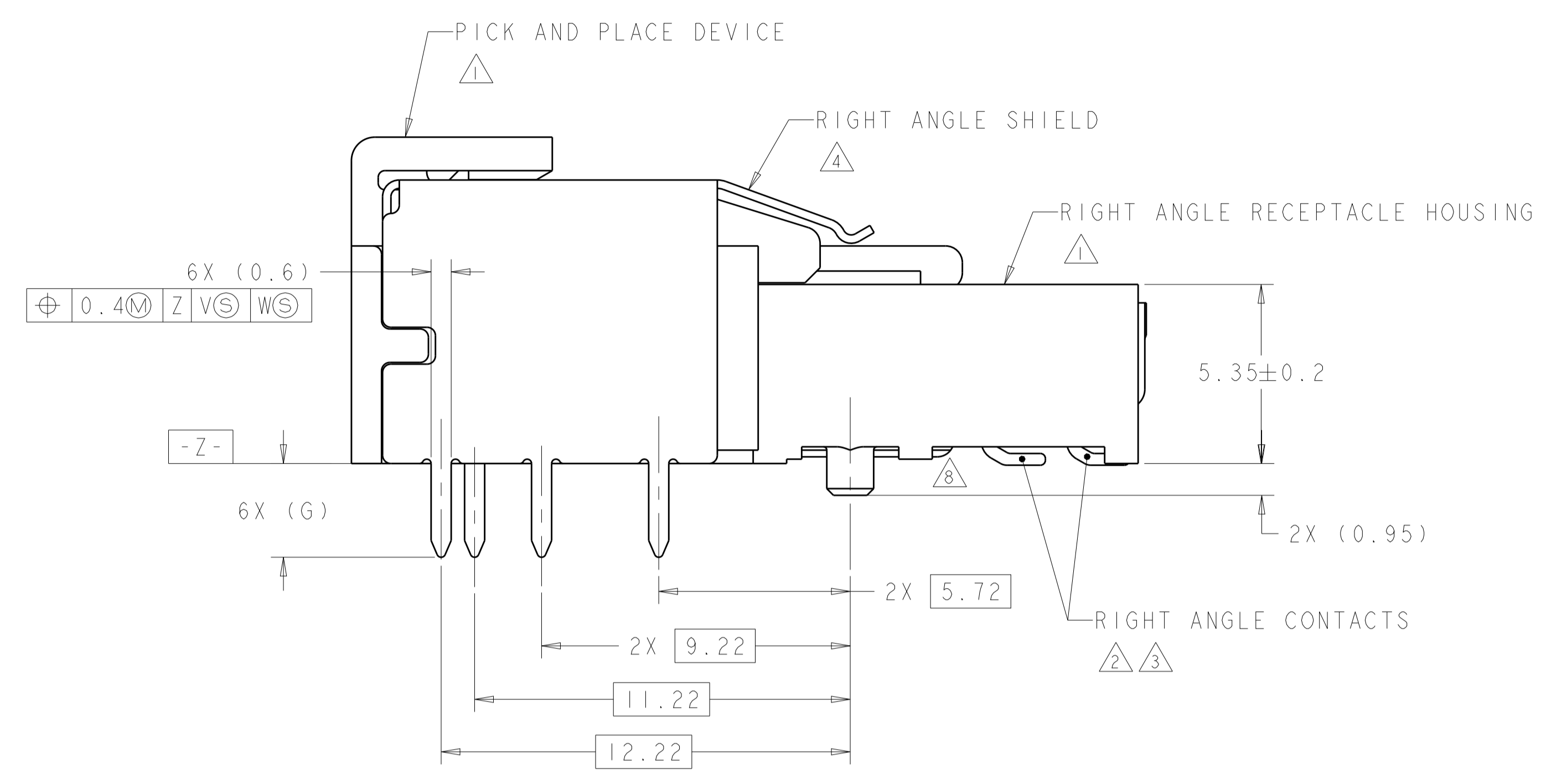
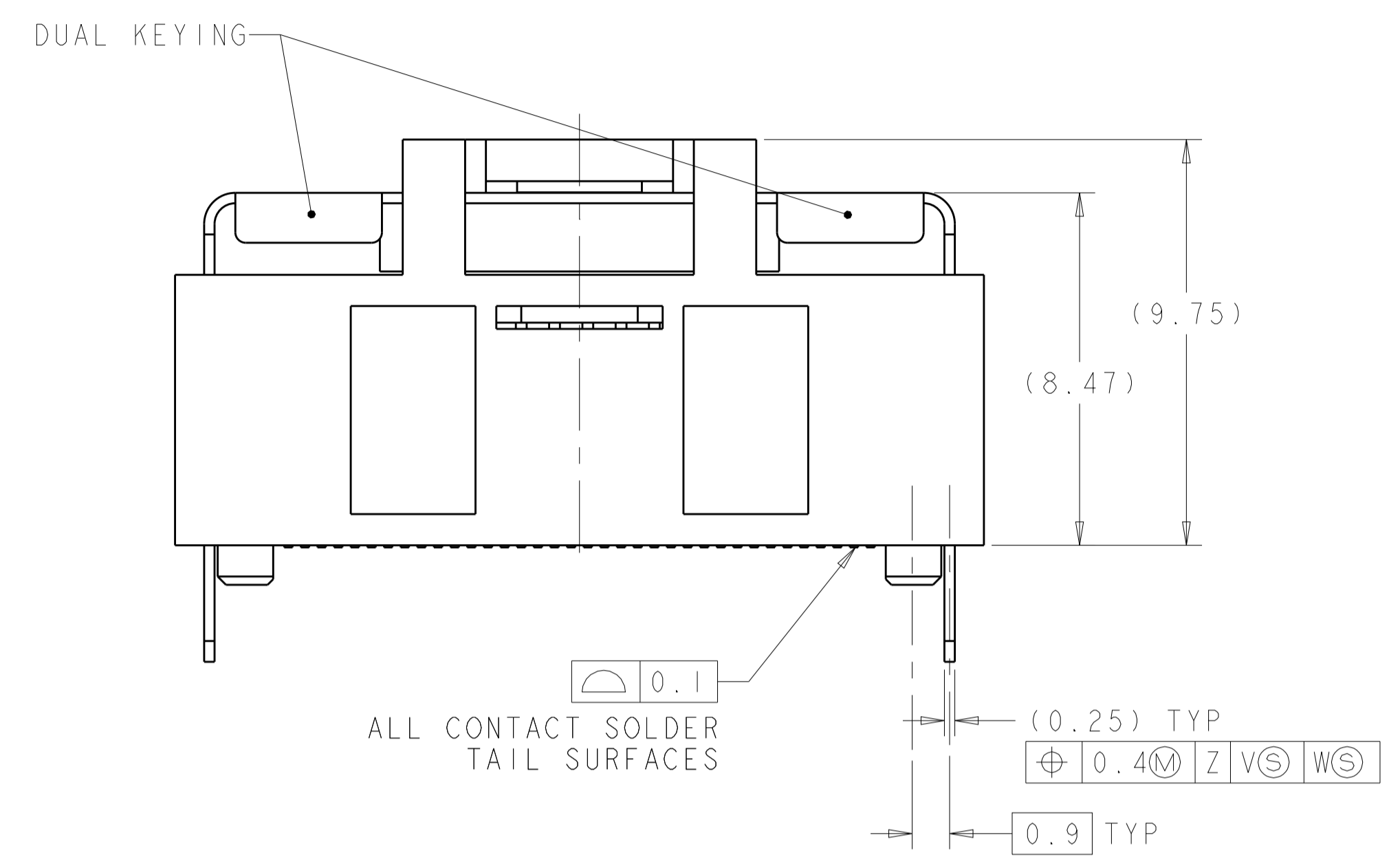

| | | | |
|---|--|-----------------------------|---|
| THIS DRAWING IS A CONTROLLED DOCUMENT. | | DMN: M. E. CONNER 18JUL2005 | TE Connectivity NAME: EVERCLEAR Mini-SAS RIGHT ANGLE INTERNAL RECEPTACLE ASSEMBLY WITH DUAL KEYED SHELL PRODUCT SPEC: 108-2234 APPLICATION SPEC: SIZE: A1 CAGE CODE: 00779 DRAWING NO: C=1888019 RESTRICTED TO: CUSTOMER DRAWING |
| DIMENSIONS: mm | | CHK: R. R. HENRY 18JUL2005 | |
| TOLERANCES UNLESS OTHERWISE SPECIFIED: 0 PLC ± 1 PLC ± 2 PLC ± 3 PLC ± 4 PLC ± ANGLES ± | | APVD: R. R. HENRY 18JUL2005 | |
| MATERIAL: SEE NOTES FINISH: SEE TABLE | | WEIGHT: - | |
| SCALE: 8:1 | | SHEET: 3 OF 4 | REV: B4 |