

GSD

1945-19-102

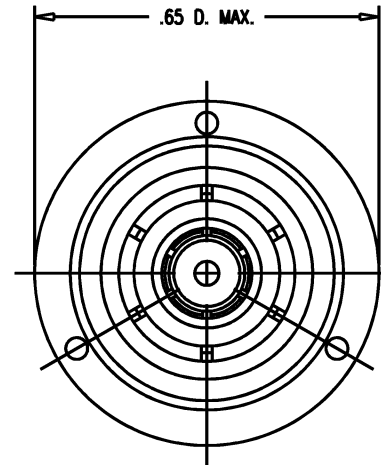
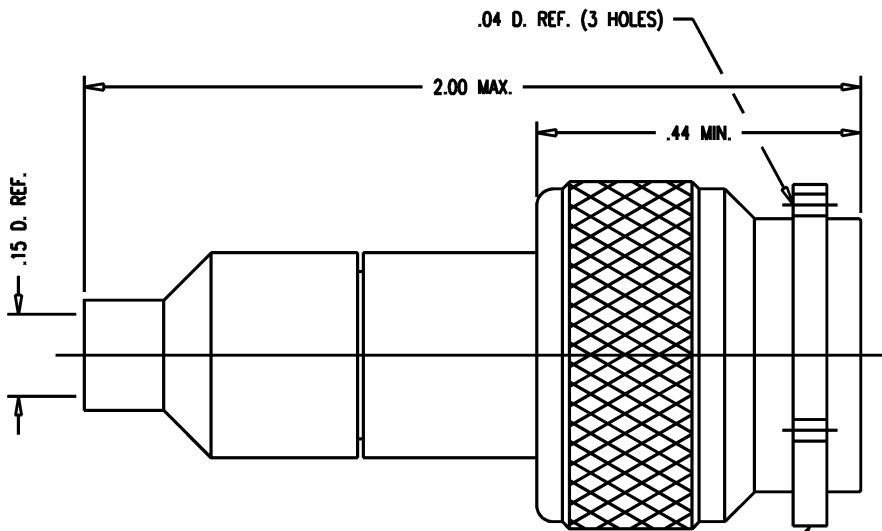

STAMP: KINGS 1945-19-102
YRWK (DATE CODE)

NOTES:

1. FOR USE WITH MIL 17/176-00002 CABLE.
2. FOR CABLING INSTRUCTIONS SEE 3-400.
3. FOR CRIMPING USE DIE KTH-2175.
4. INTERFACE PER MIL-STD-348, FIG. 202-1.
5. PACKAGE MARKED: 500135-1 CONNECTOR, PLUG, TRIAXIAL
1945-19-102 SERIES TRT
6. PACKAGE MARKED: PAT. 4804344
7. MATERIALS:
 - INSULATORS: ASTM-D-1457
 - K-GRIP SLEEVE: COM. BRONZE, ALLOY 220
 - GASKET: SILICONE RUBBER, ZZ-R-765
 - C-RING: PHOS. BRONZE, QQ-B-750
 - INTER. CONTACT } BER. COPPER, ASTM-B-196
 - OUTER CONTACT }
 - SPRING WASHER }
 - ALL OTHER METAL PARTS: BRASS, ASTM-B16
8. FINISHES:
 - TRB INTER. CONTACT } HARD GOLD PLATE PER MIL-G-45024
 - TRB CRIMP CONTACT M }
 - ALL OTHER METAL PARTS: SILVER PLATE PER QQ-S-365
9. ELECTRICAL CHARACTERISTICS:
 - WORKING VOLTAGE: 400 VRMS
 - FREQUENCY RANGE: DC TO 500 MHz

REVISIONS

ISSUE	CHANGES
2	CN 34016 E REDRAWN JCA 08/20/92
3	CN 38252 C BDH 03/14/01
4	CN 38988 E TML 12/22/03

JCA3025

SCALE 4:1	
APPROX SURFACE AREA	
USED ON	
REF: McDONNELL DOUGLAS 500135 REV. B	
PLUG, TRT (MONOCRIMP)	
DRAWN JCA	DATE 08/20/92
DESIGN VLS	DATE 08/21/92
APPR. VLS	DATE 08/24/92

KINGS
ELECTRONICS CO., INC.
ROCK HILL, SOUTH CAROLINA 29730

1945-19-102

GSD