

THIS DRAWING IS UNPUBLISHED. RELEASED FOR PUBLICATION		
© COPYRIGHT - By - ALL RIGHTS RESERVED.		
HOUSING CLAMP NUT INNER SLEEVE WASHER WEDGE	BRASS PER QQ-B-626 COMP. 360	GOLD PLATED PER ASTM-B-488 OVER NICKEL PLATE PER AMS-QQ-N-290 COPPER PLATE PER AMS-2418
DIELECTRIC	TFE FLUOROCARBON PER ASTM-D-1457, MIL-P-19468, AND FED. SPEC L-P-403	N/A
CENTER CONTACT	BERYLLIUM COPPER PER ASTM B196, ALLOY 173	GOLD PLATED PER ASTM-B-488 OVER NICKEL PLATE PER AMS-QQ-N-290 COPPER PLATE PER AMS-2418
RETAINING RING	BERYLLIUM COPPER PER ASTM B194	GOLD PLATE PER ASTM-B-488 OVER COPPER PLATE PER AMS-2418
SLEEVE CAP	BRASS PER QQ-B-626 COMP. 360	GOLD PLATE PER ASTM-B-488 OVER COPPER PLATE PER AMS-2418
COMPONENT	MATERIAL	FINISH

LOC		DIST		REVISIONS			
-	-	P	LTR	DESCRIPTION	DATE	DWN	APVD
		A		RELEASED PER ECO 13-00249	2-6-13	CT	DW

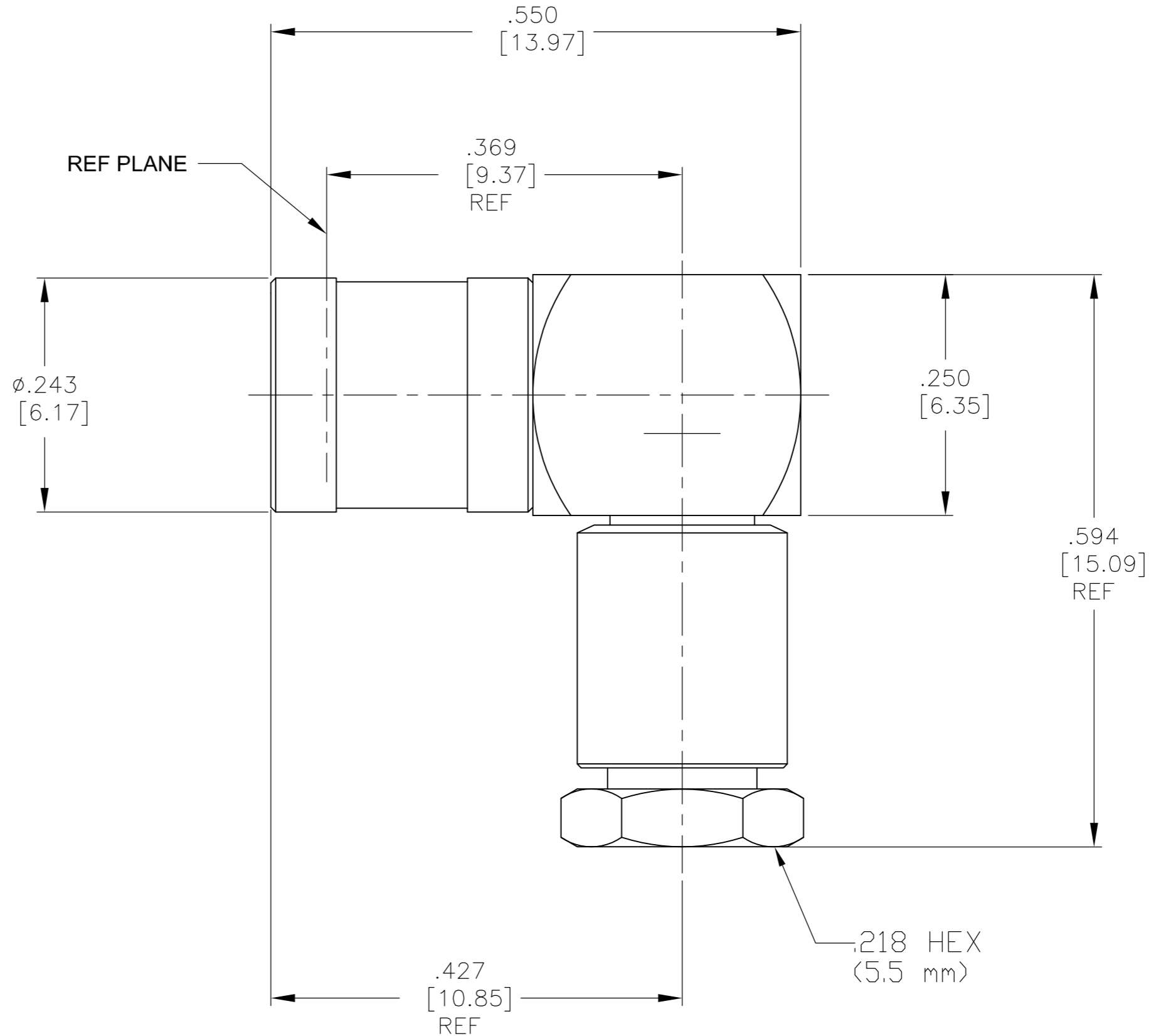

1. CAPTURED CENTER CONTACT.

DESIGNED TO USE MIS-20057/5-001 CABLE CABLE ENTRY DIAMETER MIN
INNER SLEEVE: .065 [1.65]
CONTACT: .028 [0.71]
CLAMP NUT: .112 [2.84]

1996185-1  
PART NUMBER

THIS DRAWING IS A CONTROLLED DOCUMENT. DIMENSIONING AND TOLERANCING PER ASME Y14.5M (ISO STANDARDS)		DWN C.C.THOMAS 06FEB2013	TE Connectivity	
DIMENSIONS: INCHES [mm]		CHK D.WILSON 2-6-13	NAME	
TOLERANCES UNLESS OTHERWISE SPECIFIED: 0 PLC ± - 1 PLC ± - 2 PLC ± - 3 PLC ± .005 [0.13] 4 PLC ± - ANGLES ± -		APVD D.WILSON 2-6-13	SMB RT ANGLE SNAP ON CABLE PLUG ASSY, CLAMP ATTACHMENT	
MATERIAL SEE TABLE	FINISH SEE TABLE	APPLICATION SPEC 408-4729	SIZE A2	CAGE CODE 00779
		WEIGHT -	DRAWING NO C=1996185	RESTRICTED TO -
		CUSTOMER DRAWING	SCALE 8:1	SHEET 1 of 1
			REV A	