

SMP

Short Circuit
Jack

19K12S-000D3

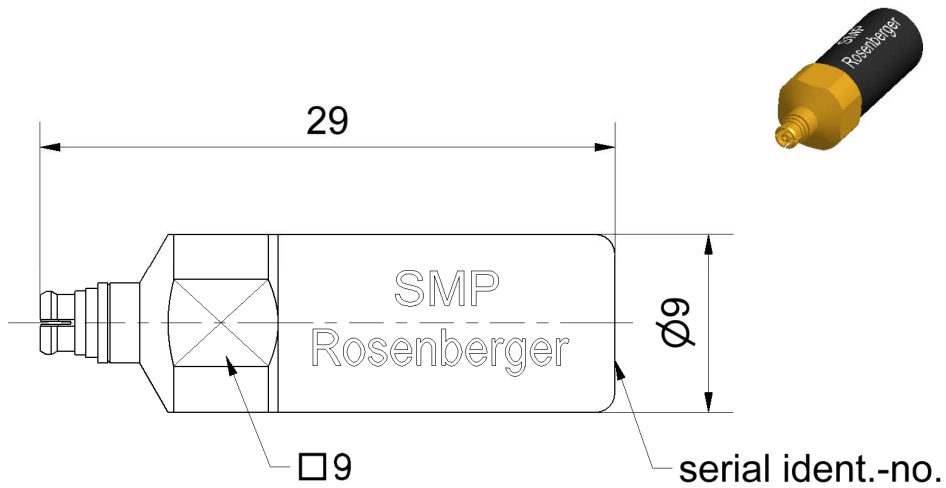

All dimensions are in mm; tolerances according to ISO 2768 m-H

Interface

According to

MIL-STD-348

Documents

Application note

AN001 "Calibration Services"

Material and plating

Connector parts

Center conductor
Outer conductor

Material

CuBe
CuBe

Plating

Gold, min. 1.27 µm, over nickel
Gold, min. 1.27 µm, over nickel

Dieses Dokument ist urheberrechtlich geschützt • This document is protected by copyright • Rosenberger Hochfrequenztechnik GmbH & Co. KG

RF_35/09.14/6.2

Electrical data

Frequency range	DC to 40 GHz
Return loss	≤ 0.20 dB, DC to 4 GHz ≤ 0.40 dB, 4 GHz to 18 GHz ≤ 0.80 dB, 18 GHz to 40 GHz
Error from nominal phase ¹	≤ 2.5°, DC to 4 GHz ≤ 6.0°, 4 GHz to 18 GHz ≤ 8.0°, 18 GHz to 40 GHz

¹ The nominal phase is defined by the Offset Delay, the Offset Loss and the Short Inductance

Mechanical data

Mating cycles	
if mating part is Smooth bore	≥ 1000
if mating part is Limited detent	≥ 500
if mating part is Full detent	≥ 100
Engagement force	
- Smooth bore	9 N
- Limited detent	45 N
- Full detent	68 N
Disengagement force	
- Smooth bore	2.2 N
- Limited detent	9 N
- Full detent	22 N
Gauge	0.00 mm to 0.05 mm

General standard definition

For proper operation the vector network analyzer (VNA) needs a model describing the electrical behaviour of this calibration standard. The different models, units, and terms used will depend on the VNA type and they will have to be entered into the VNA. All values are based on typical geometry and plating.

Offset Z_o / Impedance / Z_o	50 Ω
Offset Delay	21.6816 ps
Length (electrical) / Offset Length	6.50 mm
Offset Loss	3.50 G Ω /s
Loss	0.0131 dB/ $\sqrt{\text{GHz}}$
Short Inductance ²	

² Short Inductances are determined individually for each Short circuit and are documented in a Calibration Certificate.

Environmental data

Operating temperature range ³	+20 °C to +26 °C
Rated temperature range of use ⁴	0 °C to +50 °C
Storage temperature range	- 40 °C to +85 °C

RoHS compliant

³ Temperature range over which these specification are valid.

⁴ This range is underneath and above the operating temperature range, within the short circuit is fully functional and could be used without damage.