

**GLASS PASSIVATED JUNCTION PLASTIC RECTIFIER**

**VOLTAGE RANGE 50 to 1000 Volts CURRENT 1.0 Ampere**

**FEATURES**

- \* High reliability
- \* Low leakage
- \* Low forward voltage drop
- \* High current capability
- \* Glass passivated junction
- \* P/N suffix V means AEC-Q101 qualified
- \* P/N suffix V means Halogen-free

**MECHANICAL DATA**

- \* Case: Molded plastic black body
- \* Epoxy: Device has UL flammability classification 94V-O
- \* Lead: MIL-STD-202E method 208C guaranteed
- \* Mounting position: Any
- \* Weight: 0.19 gram



R-1

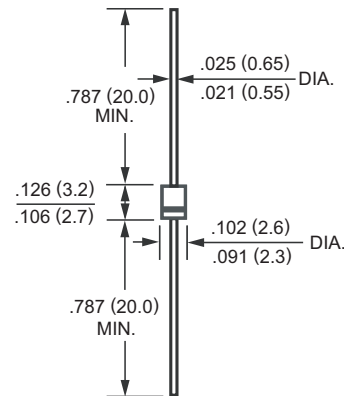

Dimensions in inches and (millimeters)

**MAXIMUM RATINGS AND ELECTRICAL CHARACTERISTICS**

Ratings at 25 °C ambient temperature unless otherwise specified.  
Single phase, half wave, 60 Hz, resistive or inductive load.  
For capacitive load, derate current by 20%.

**MAXIMUM RATINGS** (At TA = 25°C unless otherwise noted)

RATINGS	SYMBOL	1A1G	1A2G	1A3G	1A4G	1A5G	1A6G	1A7G	UNITS
Maximum Recurrent Peak Reverse Voltage	VRRM	50	100	200	400	600	800	1000	Volts
Maximum RMS Voltage	VRMS	35	70	140	280	420	560	700	Volts
Maximum DC Blocking Voltage	VDC	50	100	200	400	600	800	1000	Volts
Maximum Average Forward Rectified Current at TA = 25°C	IO	1.0							Amps
Peak Forward Surge Current 8.3 ms single half sine-wave superimposed on rated load (JEDEC method)	IFSM	25							Amps
Typical Current Squared Time	I <sup>2</sup> T	2.59							A <sup>2</sup> S
Typical Junction Capacitance (Note)	CJ	15							pF
Typical Thermal Resistance	RθJA	60							°C/W
Operating and Storage Temperature Range	TJ, TSTG	-55 to + 150							°C

**ELECTRICAL CHARACTERISTICS** (At TA = 25°C unless otherwise noted)

CHARACTERISTICS	SYMBOL	1A1G	1A2G	1A3G	1A4G	1A5G	1A6G	1A7G	UNITS
Maximum Instantaneous Forward Voltage at 1.0A DC	VF	1.0							Volts
Maximum DC Reverse Current at Rated DC Blocking Voltage	@TA = 25°C	1.0							uAmps
	@TA = 150°C	800							
Maximum Full Load Reverse Current Full Cycle Average .375" (9.5mm) lead length at TL = 75°C	IR	100							uAmps

NOTES : Measured at 1 MHz and applied reverse voltage of 4.0 volts

# RATING AND CHARACTERISTIC CURVES ( 1A1G THRU 1A7G )

FIG. 1 - TYPICAL FORWARD CURRENT DERATING CURVE

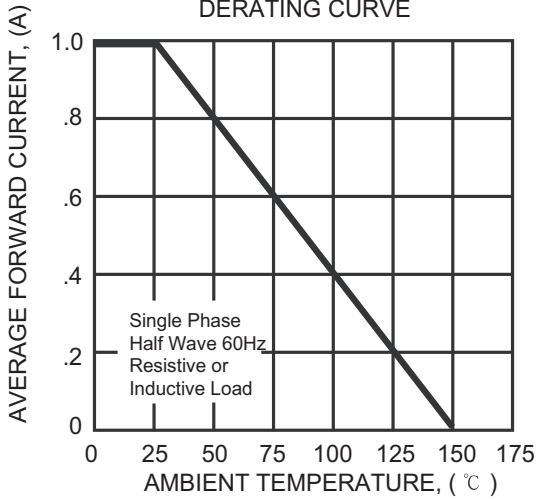

FIG. 2 - MAXIMUM INSTANTANEOUS FORWARD CHARACTERISTICS

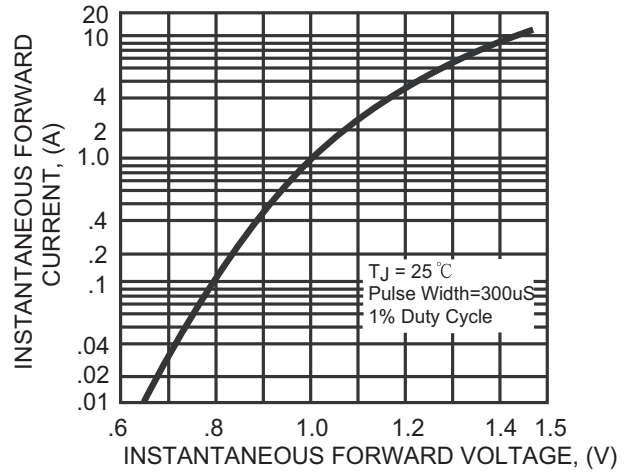

FIG. 3 - MAXIMUM NON-REPETITIVE FORWARD SURGE CURRENT

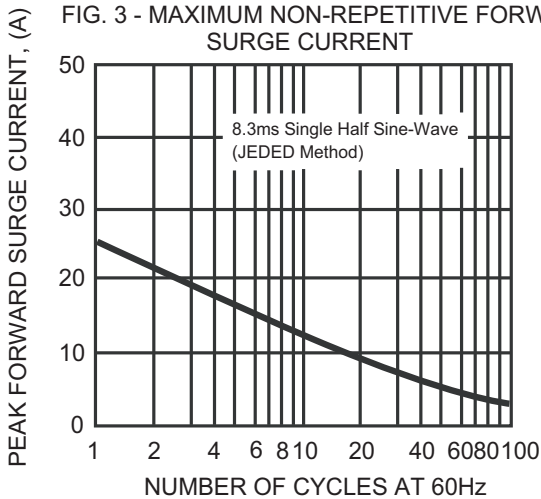

FIG. 4 - MAXIMUM REVERSE CHARACTERISTICS

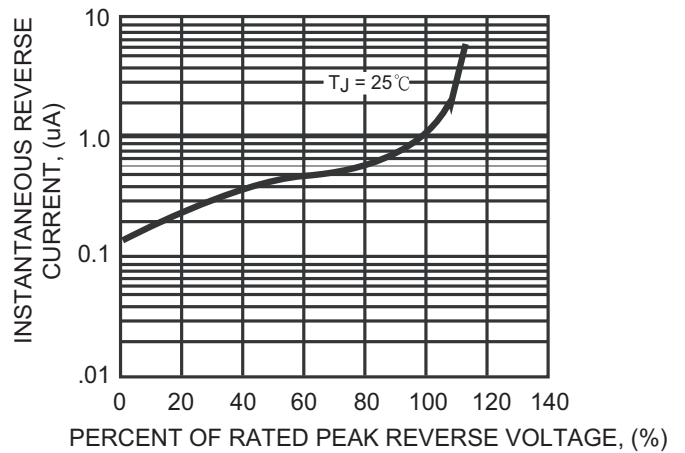
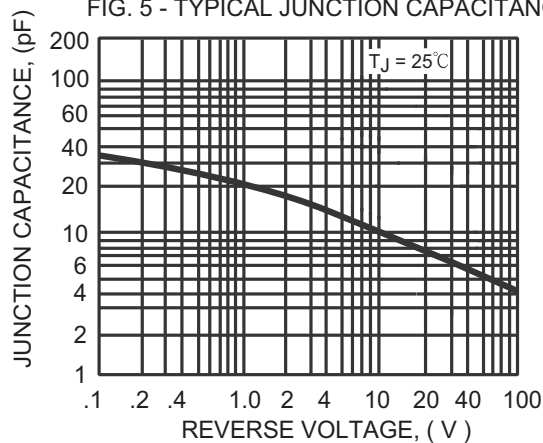

FIG. 5 - TYPICAL JUNCTION CAPACITANCE



# AXIAL LEAD TAPING SPECIFICATIONS FOR RECTIFIERS

Axial lead devices are packed in accordance with EIA standard RS-296-D and specifications given below.

COMPONENT OUTLINE	COMPONENT PITCH A	INNER TAPE PITCH B		CUMULATIVE PITCH TOLERANCE
	$\pm 0.5\text{mm} (.020")$	$\pm 0.5\text{mm} (.020")$	$\pm 1.5\text{mm} (.059")$	
T-1	5.0mm	26.0mm		2.0mm/20pitch
R-1	5.0mm	26.0mm		2.0mm/20pitch
A-405	5.0mm	26.0mm		2.0mm/20pitch
A-405	5.0mm		52.4mm	2.0mm/20pitch
DO-41	5.0mm	26.0mm		2.0mm/20pitch
DO-41	5.0mm		52.4mm	2.0mm/10pitch
DO-15	5.0mm		52.4mm	2.0mm/10pitch
R-3	5.0mm		52.4mm	2.0mm/10pitch
DO-201AD	10.0mm		52.4mm	2.0mm/10pitch
R-6	10.0mm		52.4mm	2.0mm/10pitch

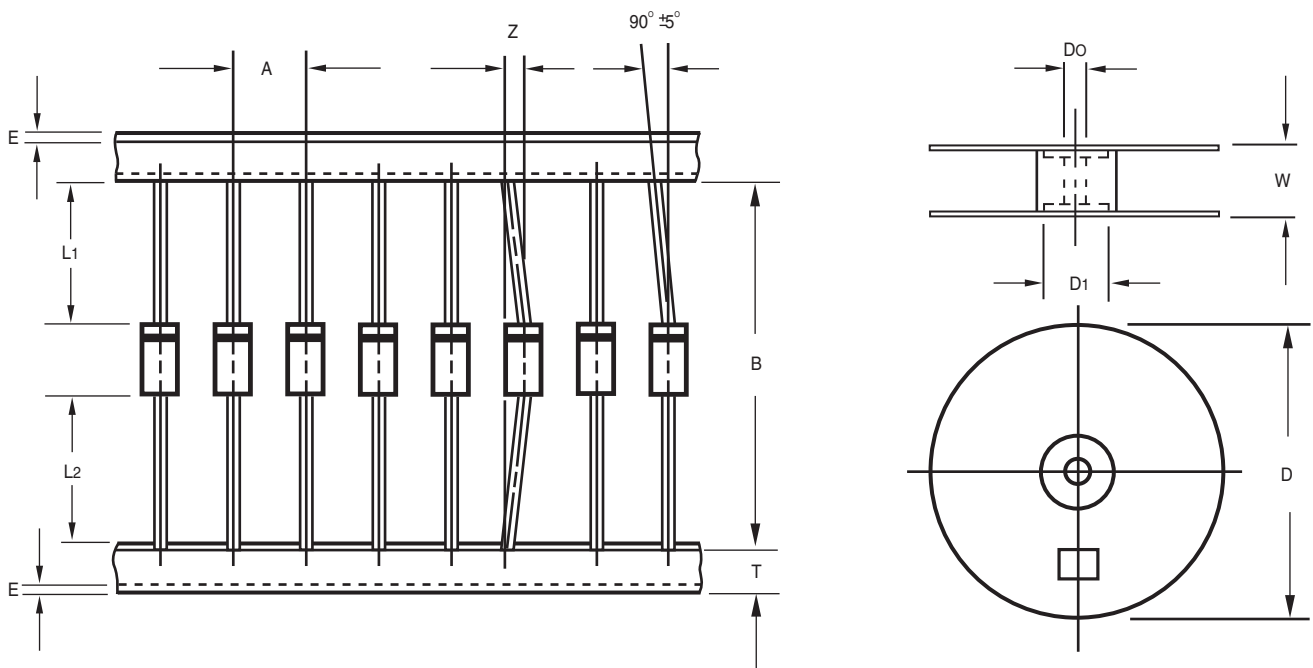

Fig.: Configuration of AXIAL LEAD TAPING

ITEM	SYMBOL	SPECIFICATIONS (mm)	SPECIFICATIONS (inch)
Component alignment	Z	1.2 Max.	0.047 Max.
Tape width	T	$6.0 \pm 0.4$	$0.236 \pm 0.016$
Exposed adhesive	E	0.8 Max.	0.032 Max.
Body eccentricity	$ L1-L2 $	1.0 Max.	0.039 Max.
Reel outside diameter	D	330.0	13.0
Reel inner diameter	D1	$85.7 \pm 0.3$	$3.374 \pm 0.012$
Feed hole diameter	Do	$30.5 \pm 0.4$	$1.201 \pm 0.016$
Reel width	W	$79.0 \pm 1.0$	$3.110 \pm 0.039$

Notes : 1. Each component lead shall be sandwiched between tapes for a minimum of 3.2mm (0.126").  
2. The reel width "W" for 26mm taping is  $50.0 \pm 1.0\text{mm} (1.97" \pm 0.040")$ .

# RADIAL-TAPING SPECIFICATIONS FOR RECTIFIERS-I TAPING

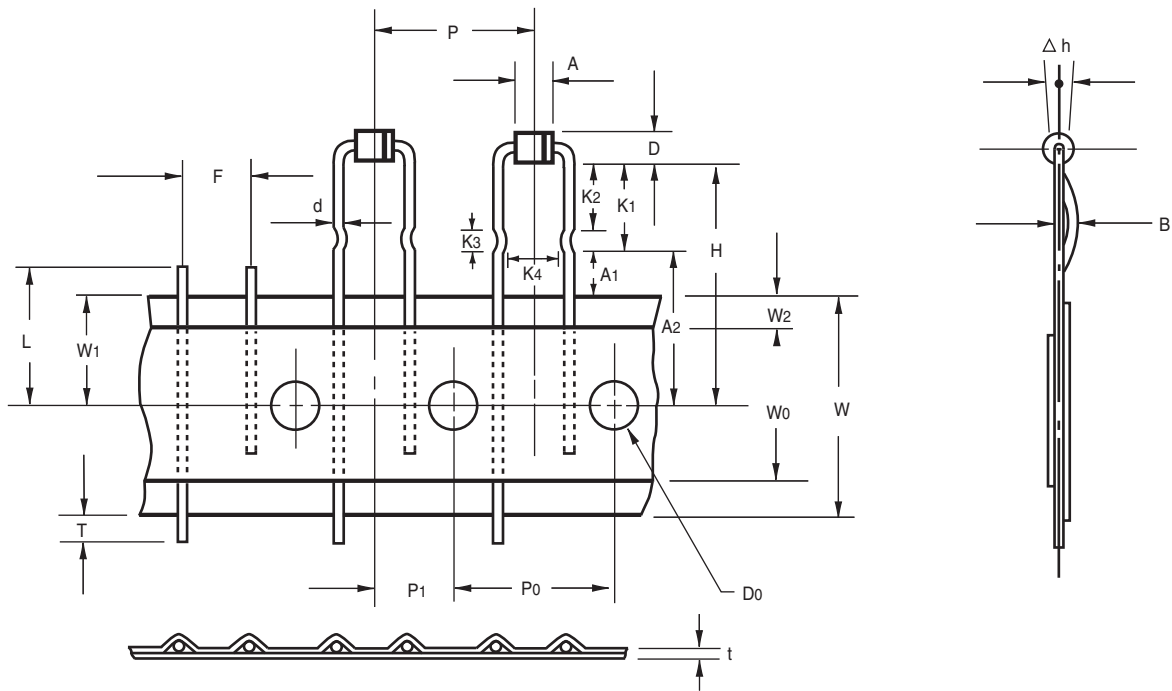

Fig.: Configuration of I-TAPING

ITEM	SYMBOL	SPECIFICATIONS(mm)	SPECIFICATIONS(inch)
Lead-wire clinch height	A2	15.5± 0.2	0.610± 0.008
Kinker height	K1	5.0± 1.0	0.197± 0.039
Kinker position	K2	3.0± 1.0	0.118± 0.039
Lead kinker length	K3	3.0± 1.0	0.118± 0.039
Component kinker spacing	K4	2.5± 1.0	0.098± 0.039
Adhesive tape position	A1	6.0 Min.	0.236 Min.
Body diameter	D	2.5± 0.2	0.098± 0.008
Body length	A	3.1± 0.3	0.122± 0.012
Lead-wire diameter	d	0.6± 0.1	0.024± 0.004
Component pitch	P	12.7± 1.0	0.500± 0.039
Feed hole pitch	P0	12.7± 1.0	0.500± 0.039
Component lead spacing	F	5.0± 0.8	0.197± 0.031
Deflection	Δh	0.0± 2.0	0.0± 0.079
Tape width	W	18.0+1.0/-0.5	0.709+0.039/-0.020
Hole-down tape width	W0	12.5 Min.	0.492 Min.
Hole position	W1	9.0+0.7/-0.5	0.354+0.028/-0.020
Length from seating plane	H	20.0± 0.5	0.787± 0.020
Feed hole diameter	D0	4.0± 0.3	0.157± 0.012
Total tape thickness	t	0.7± 0.2	0.028± 0.008
Cut out length	L	11.0 Max.	0.433 Max.
Lead protrusion	T	2.0 Max.	0.079 Max.
Center of seating plane location	P1	6.35± 0.7	0.250± 0.028
Adhesive tape position	W2	3.0 Max.	0.118 Max.
Lead bend	B	1.0 Max.	0.039 Max.

- Notes :
- 1.Devices are pecked in accordance with EIA standard RS-468and specifications listed above. Available only for R-1 product utilizing 0.6mm diameter leads.
  - 2.Maximum cumulative pitchtolerance : 1.0mm/20pitch.
  - 3.Standard packing code is "I"

# RADIAL-TAPING SPECIFICATIONS FOR RECTIFIERS-J TAPING

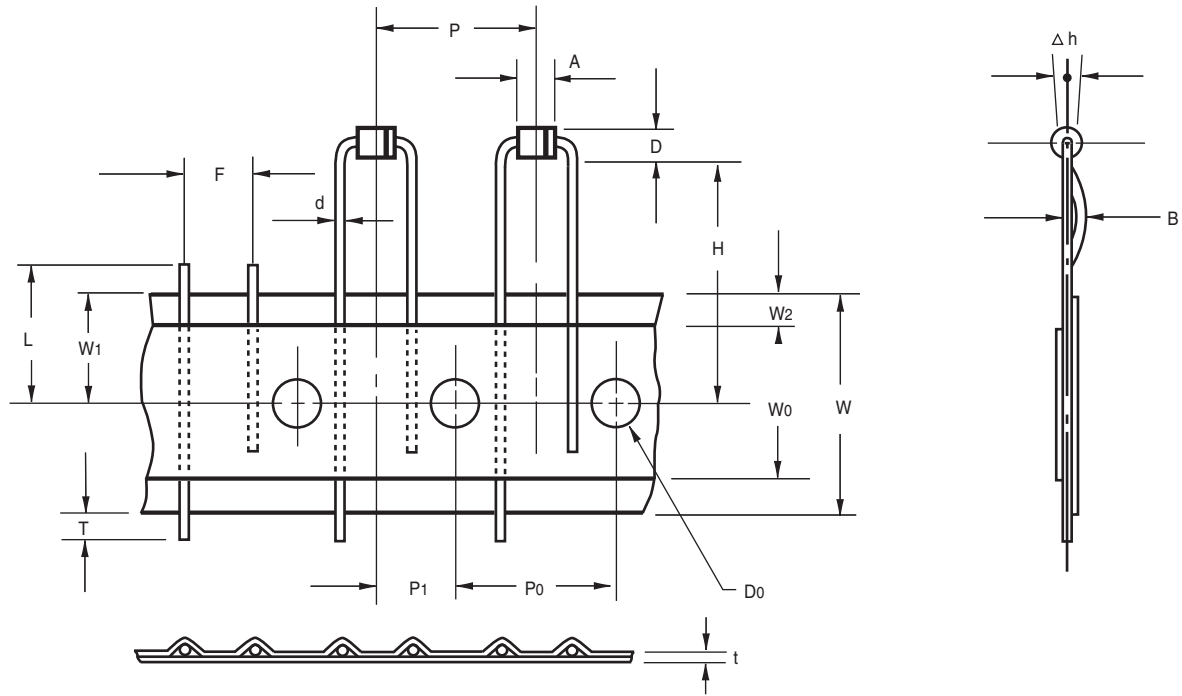

Fig.: Configuration of J-TAPING

ITEM	SYMBOL	SPECIFICATIONS(mm)	SPECIFICATIONS(inch)
Body diameter	D	2.5± 0.2	0.098± 0.008
Body height	A	3.1± 0.3	0.122± 0.012
Lead-wire diameter	d	0.6± 0.1	0.024± 0.004
Component pitch	P	12.7± 1.0	0.500± 0.039
Feed hole pitch	P0	12.7± 1.0	0.500± 0.039
Component lead spacing	F	5.0± 0.8	0.197± 0.032
Deflection	Δ h	0.0± 2.0	0.000± 0.079
Tape width	W	18.0+1.0/-0.5	0.709+0.039/-0.020
Hold-down tape width	W0	12.5 Min.	0.492 Min.
Hold-position	W1	9.0+0.7/-0.50	0.354+0.028/-0.020
Length from seating plane	H	20.0± 0.5	0.787± 0.020
Feed hole diameter	D0	4.0± 0.3	0.157± 0.012
Overall tape thickness	t	0.7± 0.2	0.028± 0.008
Cut out length	L	11.0 Max.	0.433 Max.
Lead protrusion	T	1.0 Max.	0.039 Max.
Center of seating plane location	P1	6.35± 0.7	0.250± 0.028
Adhesive tape border	W2	30 Max.	1.181 Max.
Lead bend	B	1.0 Max.	0.039 Max.

- Notes :
- 1.Devices are packed in accordance with EIA standard RS-468 and specification given above. Available only for R-1 product utilizing 0.6mm diameter leads.
  - 2.Maximum cumulative pitch tolerance:1.0mm/20pitch.
  - 3.Standard packing code is "J".

## 1. Internal Circuit



## 2. Marking on the body

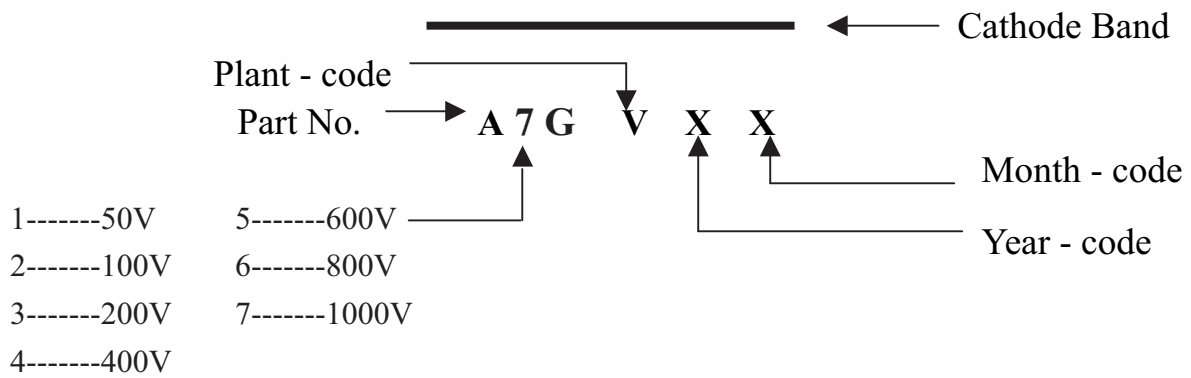

## PACKAGING OF DIODE AND BRIDGE RECTIFIERS

### REEL PACK

PACKAGE	PACKING CODE	EA PER REEL	EA PER INNER BOX	COMPONENT SPACE (mm)	TAPE SPACE (mm)	REEL DIA (mm)	CARTON SIZE (mm)	EA PER CARTON	GROSS WEIGHT(Kg)
R-1	-T	5,000	5,000	5.0	52	330	355*350*335	20,000	7.37

### AMMO PACK

PACKAGE	PACKING CODE	REEL ( EA )	COMPONENT SPACE(mm)	TAPE SPACE (mm)	BOX SIZE (mm)	CARTON SIZE(mm)	CARTON ( EA )	GROSS WEIGHT (Kg)
R-1	-F	3,000	5.0	52	255*73*100	400*268*225	30,000	8.5
R-1	-E	3,000	5.0	26	256*48*94	365*270*217	42,000	8.35
R-1	-J	3,000	12.7	---	325*170*40	355*350*335	42,000	13.93
R-1	-I	2,000	12.7	---	325*170*40	355*350*335	28,000	9.69

### BULK PACK

PACKAGE	PACKING CODE	EA PER BOX	INNER BOX SIZE (mm)	CARTON SIZE (mm)	EA PER CARTON	GROSS WEIGHT(Kg)
R-1	-B	1000	192*75*21	415*220*255	50,000	11.74