

## Installation Instructions for the 1AV Series 2 Vane Sensor

ISSUE 3

PK 87573

### WARNING

#### PERSONAL INJURY

- DO NOT USE these products as safety or emergency stop devices, or in any other application where failure of the product could result in personal injury.

**Failure to comply with these instructions could result in death or serious injury.**

#### GENERAL INFORMATION

1AV Series Hall-effect vane sensors include a Hall-effect sensor and a magnet in a common package. They are operated by passing a ferrous vane through the gap between magnet and sensor.

The vane is a low carbon cold rolled steel, type AISI, 1018 or lower in carbon content. Minimum recommended vane dimensions of 0.30 inch (7,6 mm) tooth width and .40 inch (10,1 mm) window width are required to assure appropriate operating characteristics.

#### ACTUATION

1. With no vane in gap - output is conducting (Sinking is Low).
2. Vane movement Left to Right - when leading edge reaches "b", the output voltage stops conducting (Sinking goes High).
3. After leading edge reaches "b", assuming vane moves on through the gap; as trailing edge reaches "d", the output voltage will be conducting.
4. For vane movement from Right to Left, output is nonconducting when leading edge reaches "c", and conducting when trailing edge reaches "a".

#### WIRING DIAGRAMS

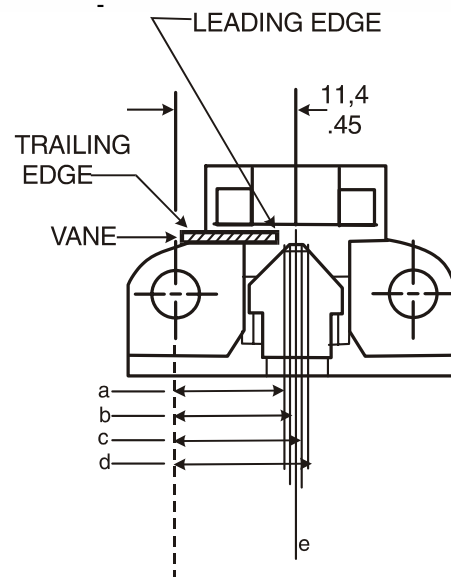
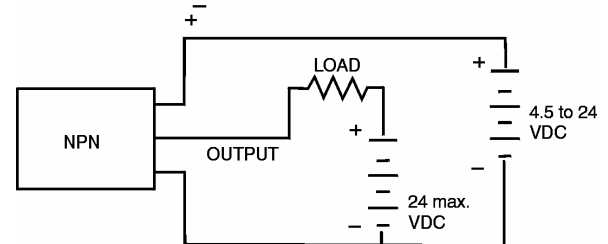
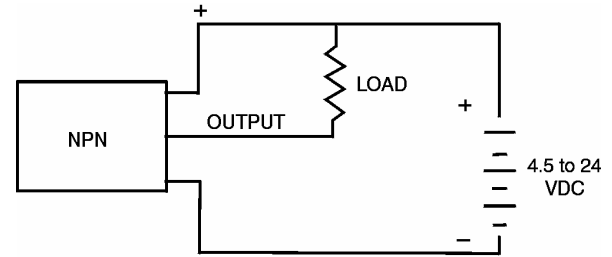

#### ELECTRICAL CHARACTERISTICS

Supply voltage	4.5 to 24 Vdc (11 ± 5 typ.)
Supply current	16.0 mA max. @ 25 °C 18.5 mA max. @ -40 °C
Output voltage	Current sinking: 0.4 V max. @ 20mA
Load current	40 mA max.
Temperature range	-40 to +125 °C (-40 to +257 °F)

#### MECHANICAL CHARACTERISTICS

Operating Range	Left			Right			Differential L-R, R-L (c-a), (d-b)
	Operate (a)	Release (b)	Diff. (b-a)	Operate (d)	Release (c)	Diff. (d-c)	
12 VDC, 25°C	.39 ± .03	.41 ± .03	.02 ± .014	.51 ± .03	.49 ± .03	.02 ± .014	.10 ± .04

## MOUNTING DIMENSIONS (for reference only)

mm  
in.

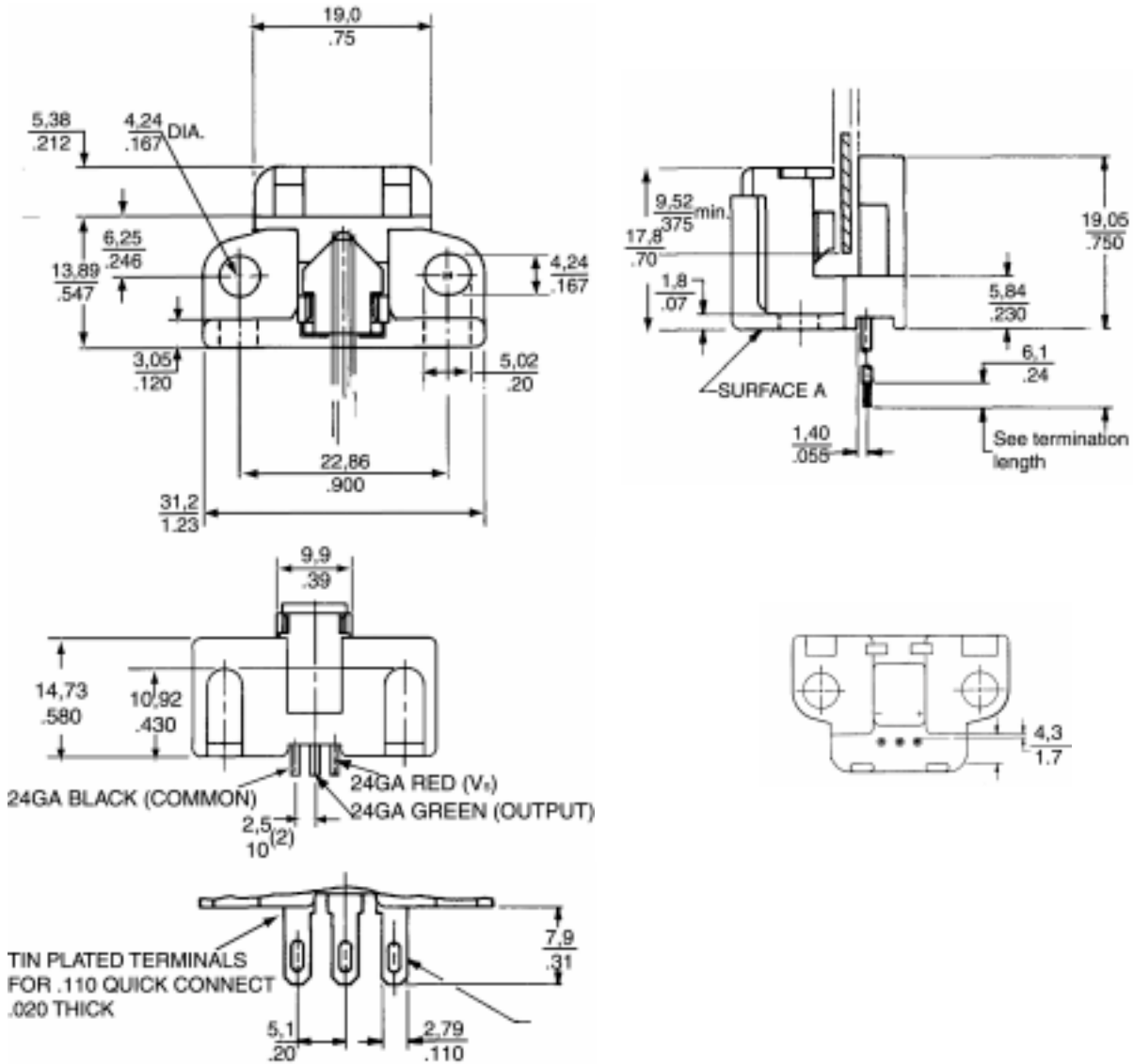

## VANE DIMENSIONS

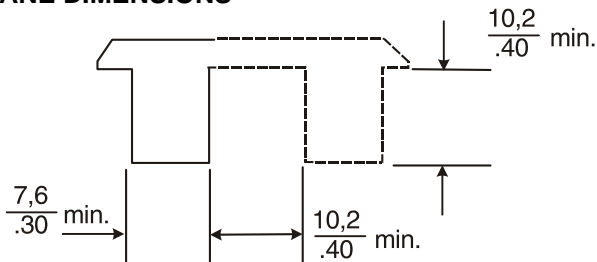

## TERMINALS

1	Vs
2	Output
3	Common

## LEADWIRES

Red	Vs
Green	Output
Black	Common

## CATALOG LISTINGS

Listing	Type	Termination Style	Lead Length (inches)
1AV11F	Open Collector	Terminal	0.31 ± 0.05
1AV12F	NPN	Leadwire	7.00 ± 0.50
1AV13F	Current Sinking	Leadwire	24.50 ± 1.00

## CIRCUIT DIAGRAM NPN (SINKING)

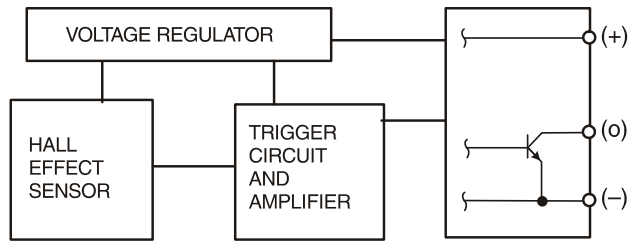

## TROUBLESHOOTING

If sensor does not operate, follow these steps:

1. Make certain all wiring is correct (load must be connected).
2. Measure supply voltage across positive and ground (leads/terminals) to verify that proper supply voltage is present.
3. Connect positive lead of voltmeter to output (lead/terminal). Readings should be:

No vane in gap	0.4 V max.
Vane in gap	Vs