

SILICON MIXER DIODE

DESCRIPTION:

The **ASI 1N21WE** is a Silicon Mixer Diode Designed for Applications Operating From 8.0 to 12.4 GHz.

FEATURES:

- High burnout resistance
- Low noise figure
- Hermetically sealed package

MAXIMUM RATINGS

I_F	20 mA
V_R	1.0 V
P_{DISS}	5.0 (ERGS) @ T _C = 25 °C
T_J	-55 °C to +150 °C
T_{STG}	-55 °C to +150 °C

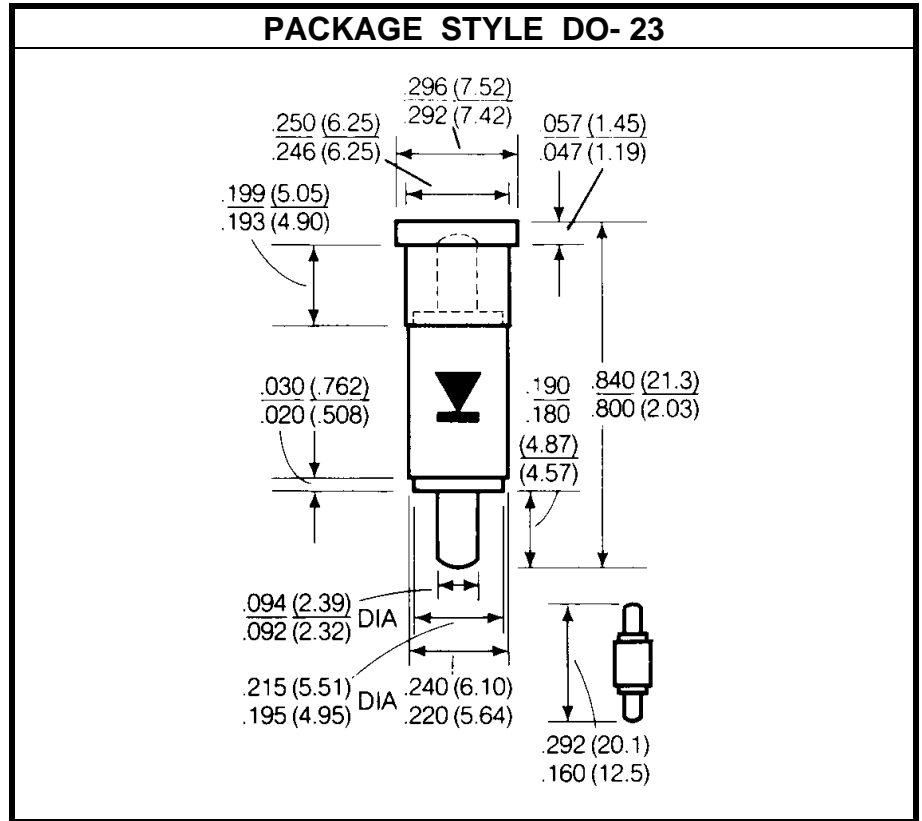
CHARACTERISTICS T_C = 25 °C

SYMBOL	TEST CONDITIONS	MINIMUM	TYPICAL	MAXIM	UNITS
N_F	F = 3060 MHz R _L = 100 Ω P _{io} = 0.5 mW I _F = 30 MHz N _{Fif} = 1.5 dB			7.0	dB
V_{SWR}				1.3	
Z_{IF}	R _L = 22 Ω f = 1000 Hz	350		450	Ω
frange		8.0		12.4	GHz