

Small Signal Diode

1N5282

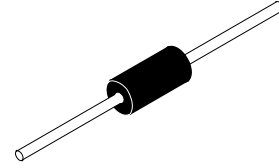

**AXIAL LEAD (DO-35)
CASE 017AG**
(Color Band Denotes Cathode)

ABSOLUTE MAXIMUM RATINGS ($T_A = 25^\circ\text{C}$ unless otherwise noted)

Symbol	Parameter	Value	Unit
V_{RRM}	Maximum Repetitive Reverse Voltage	80	V
$I_{F(AV)}$	Average Rectified Forward Current	200	mA
I_{FSM}	Non-repetitive Peak Forward Surge Current Pulse Width = 1.0 s Pulse Width = 1.0 μs	1.0	A
		4.0	A
T_{STG}	Storage Temperature Range	-65 to +200	$^\circ\text{C}$
T_J	Operating Junction Temperature	175	$^\circ\text{C}$

Stresses exceeding those listed in the Maximum Ratings table may damage the device. If any of these limits are exceeded, device functionality should not be assumed, damage may occur and reliability may be affected.

- These ratings are based on a maximum junction temperature of 200°C .
- These are steady state limits. The factory should be consulted on applications involving pulsed or low duty cycle operations.

THERMAL CHARACTERISTICS

Symbol	Parameter	Value	Unit
P_D	Power Dissipation	500	mW
$R_{\theta JA}$	Thermal Resistance, Junction to Ambient	300	$^\circ\text{C}/\text{W}$

ELECTRICAL CHARACTERISTICS ($T_A = 25^\circ\text{C}$ unless otherwise noted)

Symbol	Parameter	Test Conditions	Min	Typ	Max	Unit
V_R	Breakdown Voltage	$I_R = 5 \mu\text{A}$	80	-	-	V
V_F	Forward Voltage	$I_F = 0.1 \text{ mA}$	0.45	-	0.49	V
		$I_F = 1.0 \text{ mA}$	0.55	-	0.60	
		$I_F = 10 \text{ mA}$	0.67	-	0.725	
		$I_F = 100 \text{ mA}$	0.80	-	0.90	
		$I_F = 300 \text{ mA}$	0.92	-	1.1	
		$I_F = 500 \text{ mA}$	1.05	-	1.3	
I_R	Reverse Current	$V_R = 55 \text{ V}$ $V_R = 55 \text{ V}, T_A = 150^\circ\text{C}$	-	-	100 100	nA μA
C_T	Total Capacitance	$V_R = 0, f = 1.0 \text{ MHz}$	-	-	2.5	pF
t_{rr1}	Reverse Recovery Time	$I_F = I_R = 10 \text{ mA}, R_L = 100 \Omega$ $I_{rr} = 1.0 \text{ mA}$	-	-	4	ns
t_{rr2}	Reverse Recovery Time	$I_F = I_R = 200 \text{ mA}, R_L = 100 \Omega$ $I_{rr} = 20 \text{ mA}$	-	-	4	ns

Product parametric performance is indicated in the Electrical Characteristics for the listed test conditions, unless otherwise noted. Product performance may not be indicated by the Electrical Characteristics if operated under different conditions.

MARKING DIAGRAM

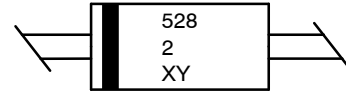

5282 = Specific Device Code
XY = Date Code

ORDERING INFORMATION

Device	Package	Shipping†
1N5282	AXIAL LEAD (Pb-Free, Halide Free)	5000 Units / Bulk
1N5282TR		10000 / Tape & Reel

†For information on tape and reel specifications, including part orientation and tape sizes, please refer to our Tape and Reel Packaging Specification Brochure, [BRD8011/D](#).

AXIAL LEAD
CASE 017AG
ISSUE 0

DATE 31 AUG 2016

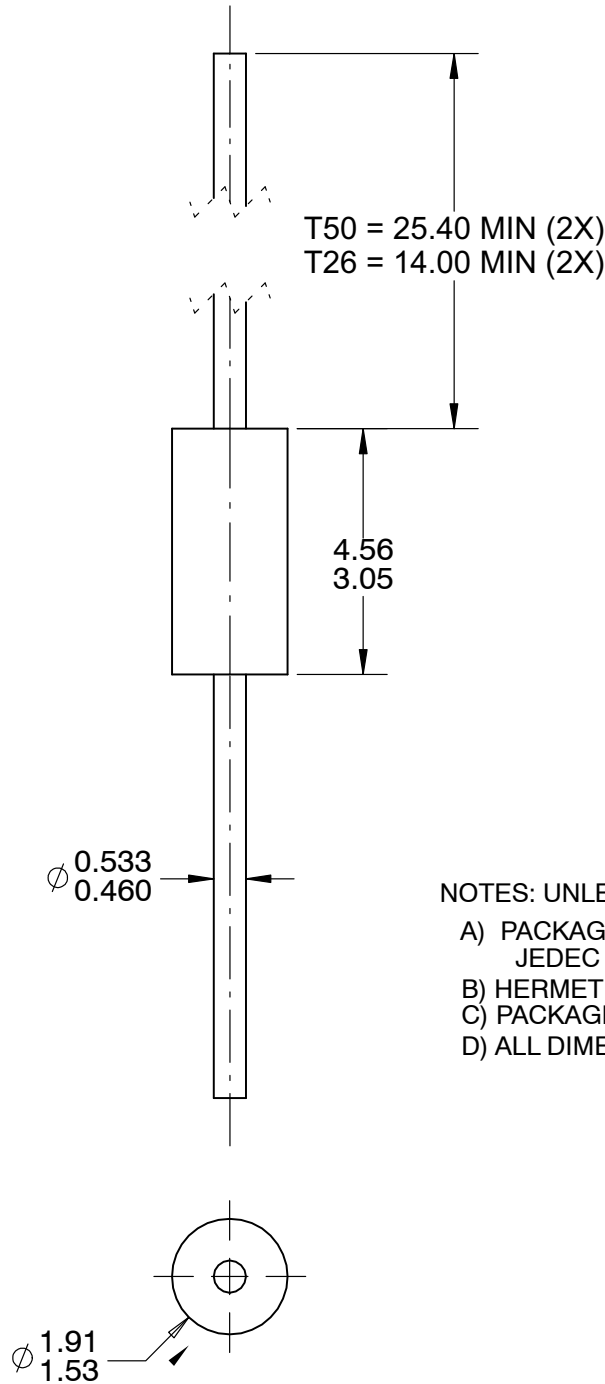

- NOTES: UNLESS OTHERWISE SPECIFIED
- A) PACKAGE STANDARD REFERENCE: JEDEC DO-204, VARIATION AH.
 - B) HERMETICALLY SEALED GLASS PACKAGE.
 - C) PACKAGE WEIGHT IS 0.137 GRAM.
 - D) ALL DIMENSIONS ARE IN MILLIMETERS.

DOCUMENT NUMBER:	98AON13443G	Electronic versions are uncontrolled except when accessed directly from the Document Repository. Printed versions are uncontrolled except when stamped "CONTROLLED COPY" in red.
DESCRIPTION:	AXIAL LEAD	PAGE 1 OF 1

ON Semiconductor and  are trademarks of Semiconductor Components Industries, LLC dba ON Semiconductor or its subsidiaries in the United States and/or other countries. ON Semiconductor reserves the right to make changes without further notice to any products herein. ON Semiconductor makes no warranty, representation or guarantee regarding the suitability of its products for any particular purpose, nor does ON Semiconductor assume any liability arising out of the application or use of any product or circuit, and specifically disclaims any and all liability, including without limitation special, consequential or incidental damages. ON Semiconductor does not convey any license under its patent rights nor the rights of others.