

1N5400-G Thru. 1N5408-G

Voltage: 50 to 1000 V

Current: 3.0 A

RoHS Device

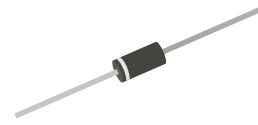

Features

- Open junction chip.
- Low reverse leakage.
- High forward surge current capability.
- High temperature soldering guaranteed 250°C/10 seconds at terminals.

Mechanical data

- Epoxy: UL 94V-0 rate flame retardant.
- Case: DO-27, molded plastic.
- Terminals: Solder plated, solderable per MIL-STD-750, method 2026.
- Polarity: Color band denotes cathode.
- Mounting position: Any.

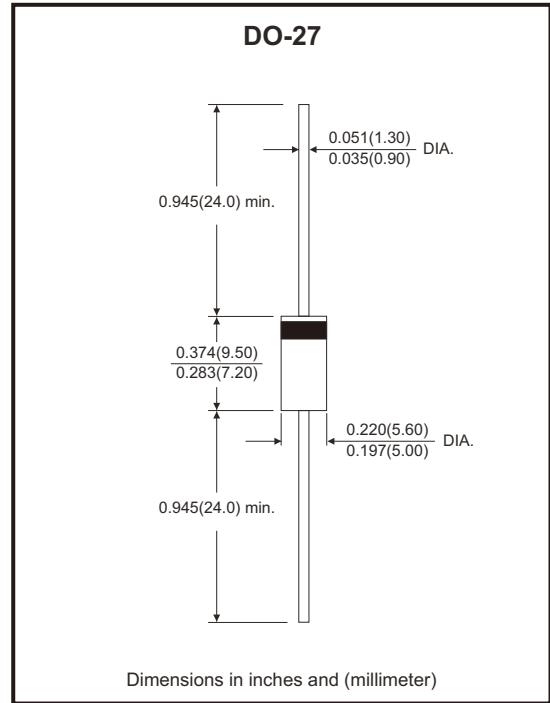

Circuit Diagram



Maximum Ratings and Electrical Characteristics

Ratings at 25°C ambient temperature unless otherwise specified.
Single phase, half wave, 60Hz, resistive or inductive load.
For capacitive load, derate current by 20%.

| Parameter | Symbol | 1N5400 -G | 1N5401 -G | 1N5402 -G | 1N5404 -G | 1N5406 -G | 1N5407 -G | 1N5408 -G | Unit |
|--|---------------------------|--------------|--------------|--------------|--------------|--------------|--------------|--------------|--------------------|
| Maximum repetitive peak reverse voltage | V_{RRM} | 50 | 100 | 200 | 400 | 600 | 800 | 1000 | V |
| Maximum RMS voltage | V_{RMS} | 35 | 70 | 140 | 280 | 420 | 560 | 700 | V |
| Maximum DC blocking voltage | V_{DC} | 50 | 100 | 200 | 400 | 600 | 800 | 1000 | V |
| Maximum average forward rectified current at $T_L=100^\circ\text{C}$ | $I_{F(AV)}$ | 3.0 | | | | | | | A |
| Peak forward surge current, 8.3ms single half sine-wave superimposed on rated load | I_{FSM} | 150 | | | | | | | A |
| Maximum instantaneous forward voltage at 3.0A | V_F | 1.10 | | | | | | | V |
| Maximum DC reverse current at rated DC blocking voltage | @ $T_A=25^\circ\text{C}$ | 10.0 | | | | | | | μA |
| | @ $T_A=125^\circ\text{C}$ | 500 | | | | | | | |
| Typical junction capacitance (Note 1) | C_J | 50 | | | | | | | pF |
| Typical thermal resistance | $R_{\theta JA}$ | 45 | | | | | | | $^\circ\text{C/W}$ |
| Operating junction and storage temperature range | T_J, T_{STG} | -55 to +150 | | | | | | | $^\circ\text{C}$ |

Notes: 1. Measured at 1MHz and applied reverse voltage of 4.0V D.C.

Company reserves the right to improve product design, functions and reliability without notice.

REV:C

Rating and Characteristic Curves (1N5400-G Thru. 1N5408-G)

Fig.1 - Derating Curve Output Rectified Current

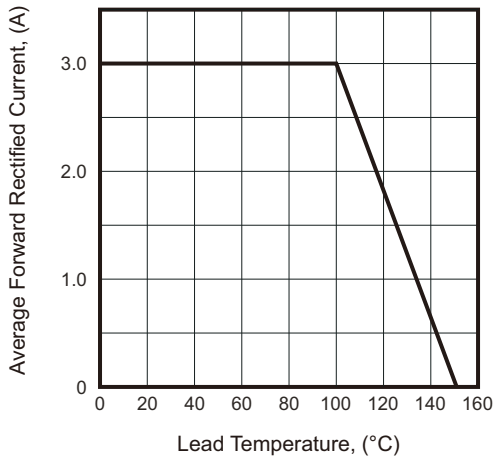

Fig.2 - Max. Non-Repetitive Peak Forward Surge Current Per Leg

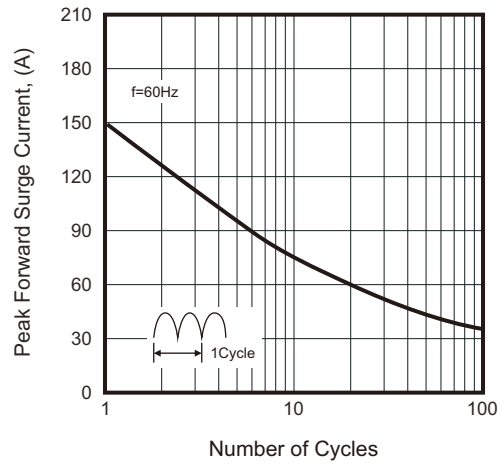

Fig.3 - Typical Forward Voltage Characteristics

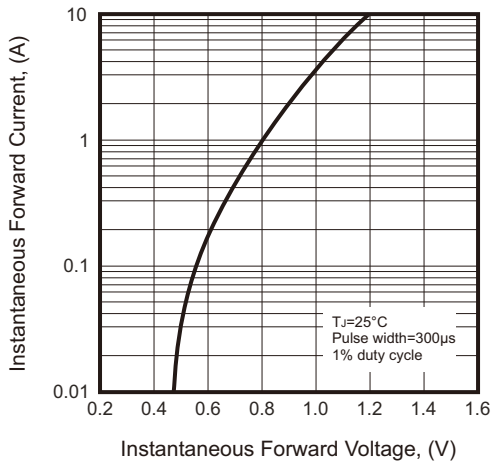
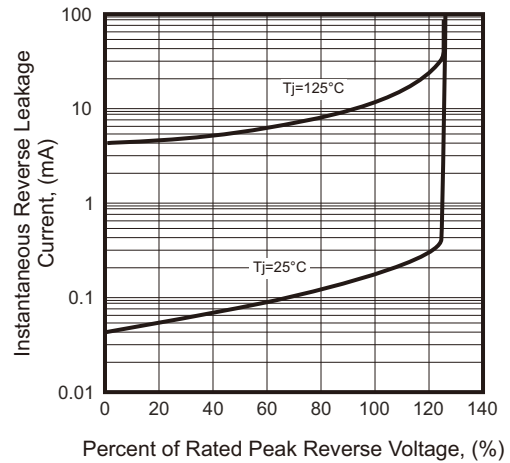
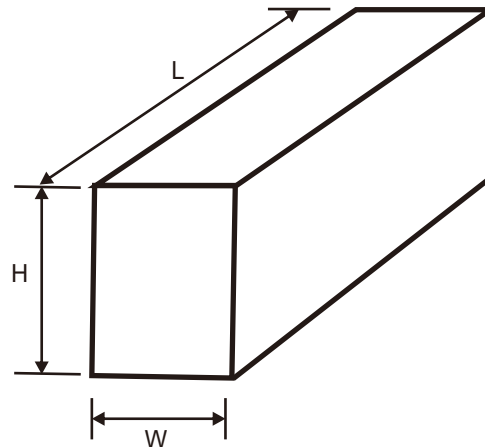
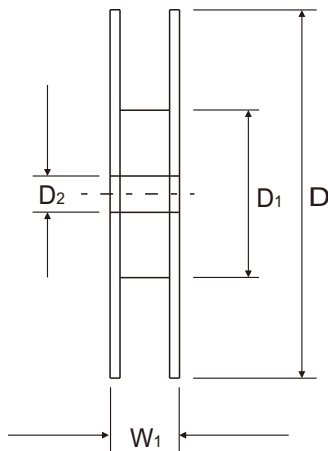
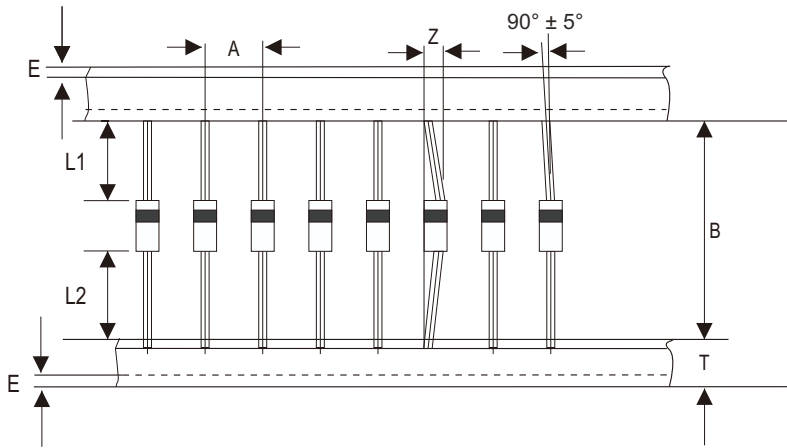

Fig.4 - Typical Reverse Leakage Characteristics



Taping Specification For Axial Lead Diodes



| DO-27 | SYMBOL | A | B | Z | T | E | L1-L2 |
|-------|--------|---------------|--------------------------|-------------|---------------|-------------|-------------|
| | (mm) | 10.00 ± 0.50 | 52.40 + 1.50 - 0.40 | 1.20 (max) | 6.00 ± 0.40 | 0.80 (max) | 1.00 (max) |
| | (inch) | 0.394 ± 0.020 | 2.063 + 0.059 - 0.016 | 0.047 (max) | 0.236 ± 0.016 | 0.031 (max) | 0.039 (max) |

| DO-27 | SYMBOL | L | W | H | D | D1 | D2 | W1 |
|-------|--------|----------------|---------------|---------------|--------|---------------|---------------|---------------|
| | (mm) | 255.00 ± 5.00 | 75.00 ± 5.00 | 150.00 ± 5.00 | 330 | 85.70 ± 0.30 | 16.60 ± 0.40 | 79.00 ± 1.00 |
| | (inch) | 10.039 ± 0.197 | 2.953 ± 0.197 | 5.906 ± 0.197 | 12.992 | 3.374 ± 0.012 | 0.654 ± 0.016 | 3.110 ± 0.039 |

Company reserves the right to improve product design , functions and reliability without notice.

REV:C