

THIS DRAWING IS UNPUBLISHED. RELEASED FOR PUBLICATION 20
 © COPYRIGHT 20 BY - ALL RIGHTS RESERVED.

LOC		DIST		REVISIONS			
P	LTR	DESCRIPTION		DATE	DWN	APVD	
	A	REVISED PER ECR-15-007373		31 JUL 2015	RS	DD	
	A1	REVISED PER ECR-18-010414		11 JUL 2018	SR	DD	
	A2	REVISED PER ECR-18-012133		01 AUG 2018	SR	DD	
	A3	REVISED PER ECR-19-000093		08 JAN 2019	SR	DD	

NOTES:

- 1. MATERIALS AND FINISH:
 - HOUSING: PBT-GF, COLOR: NATURAL
 - CONTACTS: COPPER ALLOY
 - FINISH: SEE TABLE
 - THERMAL SPRING: STAINLESS STEEL
- 2. MUST COMPLY WITH DIRECTIVE 2002/95/EC (ROHS)
- 3. REFER TO LED MANUFACTURER'S DATASHEET FOR LED DIMENSIONS
- 4. REFER TO LED DATASHEET FOR RECOMMENDED THERMAL INTERFACE MATERIALS
- 5. RECOMMENDED SCREW SIZE: M3 OR #4.
TORQUE SCREWS TO 2.5 in-lbf TO 4.0 in-lbf
- 6. WIRE TYPES AND SIZES ACCEPTED
 - 18, 20 AND 22 AWG SOLID WIRE
 - 18 AND 20 AWG PREBOND STRANDED WIRE
 - 18 AWG STRANDED WIRE (16 STRAND COUNT)
 - MAX INSULATION OD: 2.10 MM
 - STRIP LENGTH: 7.5±1.0
- 7. IN APPLICATIONS WHERE THE LED SUBSTRATE IS LESS THAN 1.50MM THICK A THERMAL SPRING IS REQUIRED. AS NOTED IN THE TABLE THE THERMAL SPRINGS WILL BE INSTALLED PRIOR TO SHIPMENT FROM THE TE FACTORY.
- 8. REQUIRES THE USE OF LED WITH GOLD PLATED PADS
- 9. RECOMMENDED PCB PAD AND HEAT SINK LAYOUT FOR LED PANEL APPLICATIONS. THE RECOMMENDED LED HOLDER FOR THESE APPLICATIONS IS PART NUMBER 1-2154857-3. IN APPLICATIONS WHERE THE LED PANEL IS LESS THAN 1.5MM THICK USE 3-2154857-3 WITH THERMAL SPRINGS IF THERMAL PRESSURE FROM THE HOLDER IS REQUIRED.
- 10. IN APPLICATIONS WHERE THE LED SUBSTRATE IS LESS THAN 1.50MM THICK AND A THERMAL SPRING IS NOT USED IT IS THE RESPONSIBILITY OF THE END USER TO ENSURE THAT ADEQUATE SYSTEM THERMAL PERFORMANCE IS ACHIEVED. THE LED HOLDER ALONE WILL NOT PROVIDE ENOUGH FORCE BY ITSELF TO GENERATE A RELIABLE AND STABLE THERMAL SOLUTION FOR THE LED.
- 11. FOR COB-TO-HOLDER CROSS REFERENCE, REFER TO APPLICATION SPECIFICATION 114-32208.

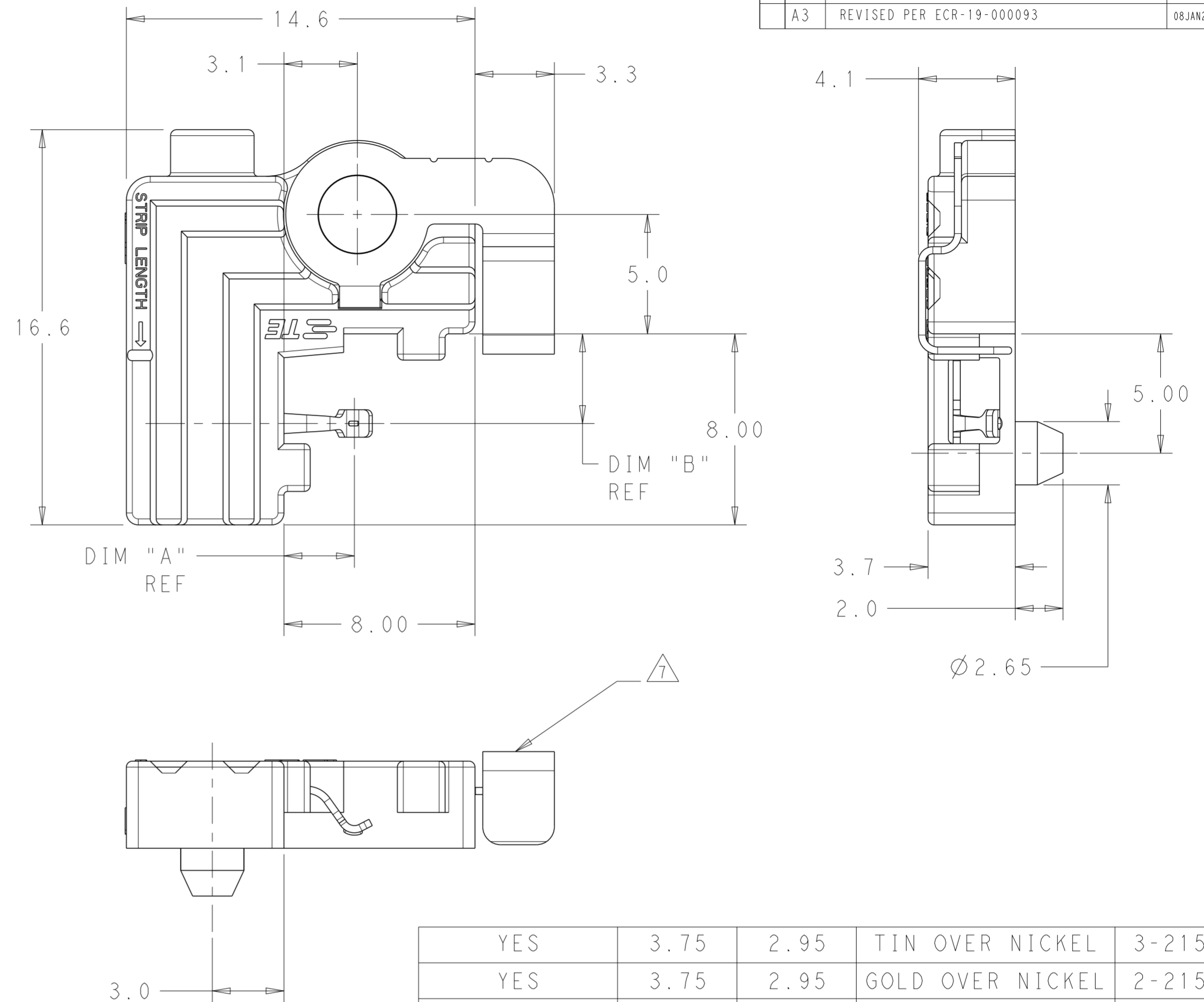

YES	3.75	2.95	TIN OVER NICKEL	3-2154857-3
YES	3.75	2.95	GOLD OVER NICKEL	2-2154857-3
YES	2.25	2.00	GOLD OVER NICKEL	2-2154857-2
YES	1.85	1.55	GOLD OVER NICKEL	2-2154857-1
NO	3.75	2.95	TIN OVER NICKEL	1-2154857-3
NO	2.25	2.00	TIN OVER NICKEL	1-2154857-2
NO	3.75	2.95	GOLD OVER NICKEL	2154857-3
THERMAL SPRING	DIM "B"	DIM "A"	CONTACT PLATING	PART NUMBER

THIS DRAWING IS A CONTROLLED DOCUMENT.

DWN: M. MOSTOLLER 16MAR2012	TE Connectivity TWO PIECE ASSEMBLY LUMAWISE LED HOLDER, SCALABLE
CHK: M. MOSTOLLER 16MAR2012	
APVD: M. MOSTOLLER 16MAR2012	
DIMENSIONS: mm	PRODUCT SPEC: 108-133005
TOLERANCES UNLESS OTHERWISE SPECIFIED:	APPLICATION SPEC: 114-32043
0 PLC ±	SIZE: A2
1 PLC ±0.2	CAGE CODE: 00779
2 PLC ±0.13	DRAWING NO: C-2154857
3 PLC ±0.001	RESTRICTED TO: -
4 PLC ±0.0001	SCALE: 6:1
ANGLES ±2	SHEET: 1 OF 3
FINISH	REV: A3

Customer Drawing

THIS DRAWING IS UNPUBLISHED. RELEASED FOR PUBLICATION 20
 © COPYRIGHT 20 BY - ALL RIGHTS RESERVED.

LED DIMENSION	DIM "C"	DIM "D"	DIM "E"	DIM "F"	RECOMMENED SOCKET PART NUMBER
25.5 X 22.3	9.70	16.30	6.30	15.80	1-2154857-2
17.5 X 13.3	5.83	11.83	1.83	11.93	1-2154857-3
15.8 X 15.80	4.95	13.05	3.05	11.05	2-2154857-1
21.0 X 21.0	7.55	15.65	5.65	13.65	2-2154857-1
13.5 X 13.5	3.80	11.90	1.90	9.90	2-2154857-1
19.0 X 19.0	6.55	14.65	4.65	12.65	2-2154857-1
28.0 X 28.0	11.05	19.15	9.15	17.15	2-2154857-2
38.0 X 38.0	16.05	24.15	14.15	22.15	2-2154857-2
28.0 X 19.0	11.05	14.65	4.65	17.15	2-2154857-3
28.5 X 28.5	11.30	19.40	9.40	17.40	2-2154857-3
22.0 X 22.0	8.05	16.15	6.15	14.15	1-2154857-3
13.35 X 13.35	3.73	11.83	1.83	9.83	2-2154857-2
15.85 X 15.85	4.98	13.08	3.08	11.08	2-2154857-2
17.85 X 17.85	5.98	14.08	4.08	12.08	2-2154857-2
17.85 X 17.85	5.98	14.08	4.08	12.08	2-2154857-2
17.85 X 17.85	5.98	14.08	4.08	12.08	2-2154857-1
23.85 X 23.85	8.98	17.08	7.08	15.08	2-2154857-2
27.35 X 27.35	10.73	18.83	8.83	16.83	2-2154857-2
34.85 x 34.85	14.48	22.58	12.58	20.58	2154857-3
13.5 X 13.5	3.80	11.90	1.90	9.90	2-2154857-1
19.0 X 19.0	6.55	14.65	4.65	12.65	2-2154857-1
24.4 X 18.0	9.25	14.15	4.15	15.35	2-2154857-2
19.0 X 16.0	6.55	13.15	3.15	12.65	2-2154857-1
24.0 X 19.0	9.05	14.65	4.65	15.15	2-2154857-1
30.0 X 30.0	12.05	20.15	10.15	18.15	3-2154857-3
19.0 X 16.0	6.55	13.15	3.15	12.65	2-2154857-2
24.0 X 20.0	9.05	15.15	5.15	15.15	2-2154857-3
17.0 X 17.0	5.55	13.65	3.65	11.65	2-2154857-3
21.5 X 21.5	7.80	15.90	5.90	13.90	2-2154857-3
28 X 28	11.05	19.15	9.15	17.15	2-2154857-2
15.0 X 12.0	4.55	11.15	1.15	10.65	2-2154857-1
24.0 X 20.0	9.05	15.15	5.15	15.15	2-2154857-3
13.25 X 13.25	3.68	11.78	1.78	9.78	2-2154857-1
17.75 X 17.75	5.93	14.03	4.03	12.03	2-2154857-2

LOC	DIST	P	LTR	DESCRIPTION	DATE	DWN	APVD
-	-	-	-	SEE SHEET 1	-	-	-

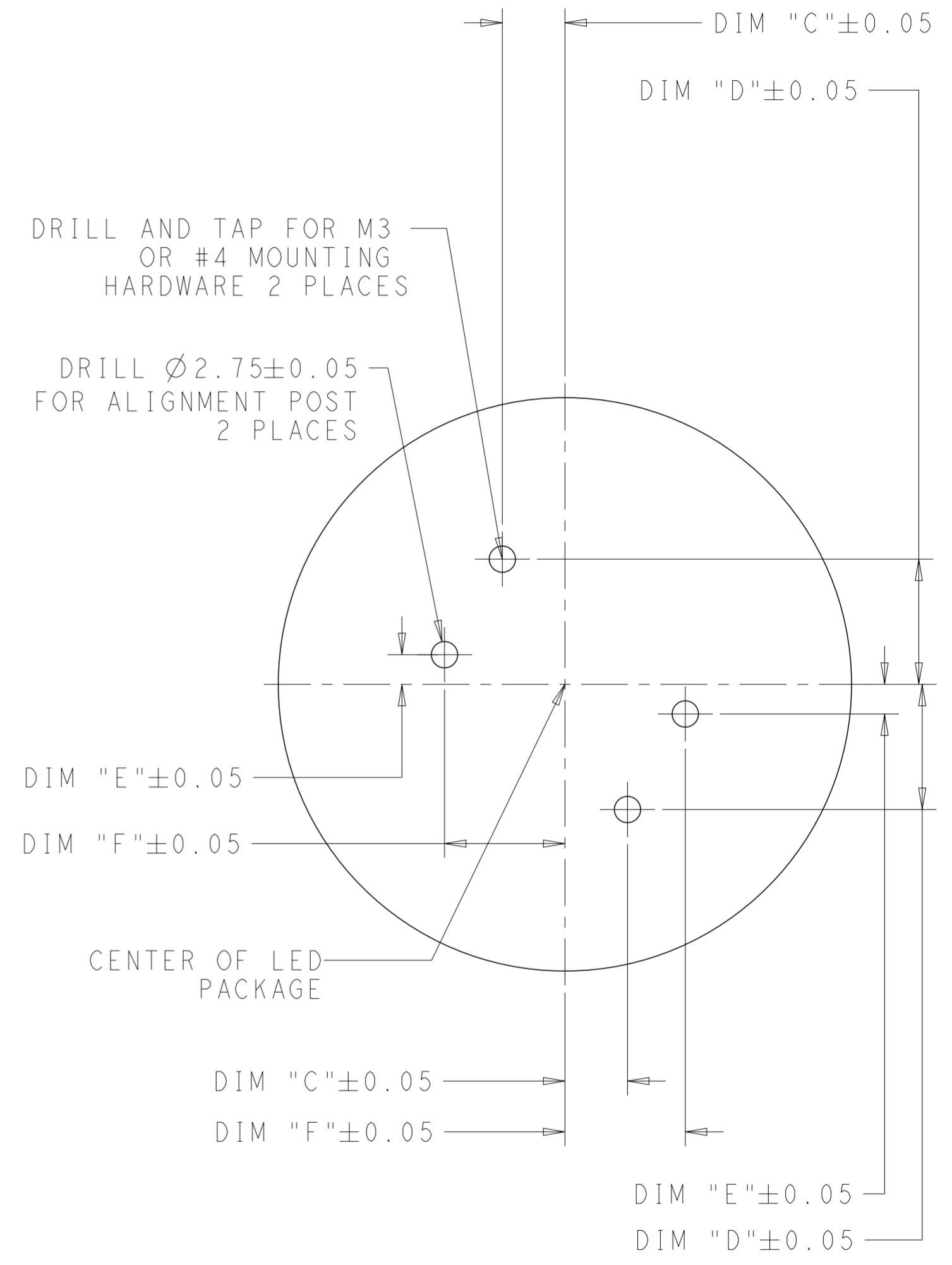

RECOMMENDED MOUNTING HOLE PATTERN

THIS DRAWING IS A CONTROLLED DOCUMENT.		DWN M. MOSTOLLER 16MAR2012	TE Connectivity	
DIMENSIONS: mm		CHK M. MOSTOLLER 16MAR2012		
TOLERANCES UNLESS OTHERWISE SPECIFIED:		APVD M. MOSTOLLER 16MAR2012	NAME TWO PIECE ASSEMBLY LUMAWISE LED HOLDER, SCALABLE	
0 PLC ±- 1 PLC ±0.2 2 PLC ±0.13 3 PLC ±0.001 4 PLC ±0.0001 ANGLES ±2 FINISH		PRODUCT SPEC 108-133005	RESTRICTED TO	
MATERIAL		APPLICATION SPEC 114-32043	SIZE A2	CAGE CODE 00779
		WEIGHT	DRAWING NO C-2154857	SCALE 6:1
		Customer Drawing	SHEET 2	OF 3 REV A3