

LOC		DIST		REVISIONS			
P	LTR	DESCRIPTION	DATE	DWN	APVD		
	A1	ECO-18-014097	06SEP2018	GCM	DD		
	A2	ECR-18-016855	26OCT2018	SR	DD		
	A3	ECR-18-017279	06NOV2018	SR	DD		
	B	REVISED PER ECR-21-118984	11NOV2021	SD	MM		

SEE SHEET 2 FOR WIRING COLOR CODE

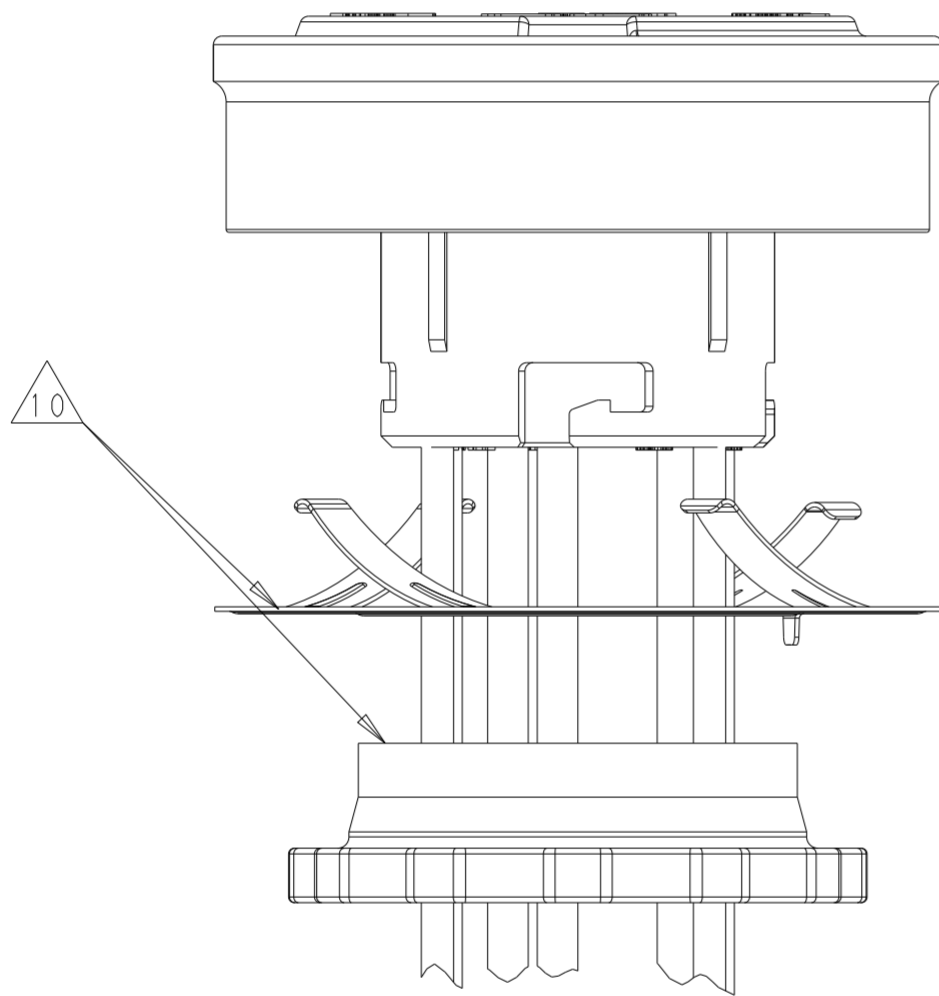
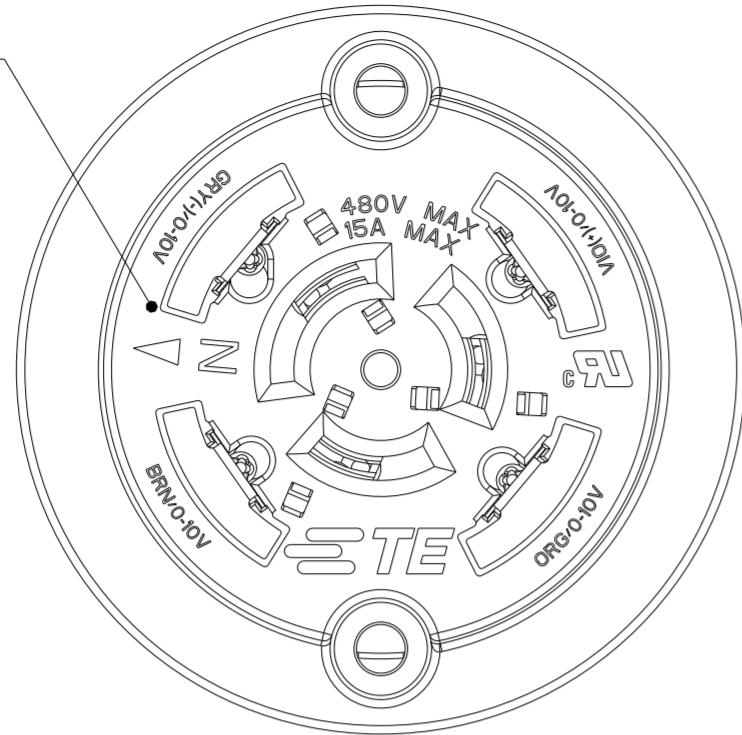

NOTES:

1. MATERIALS:
 HOUSING: GLASS-FILLED THERMOPLASTIC, UL 94V-0 RATED
 DIMMING CONTACTS (2 OR 4): COPPER ALLOY
 LINE VOLTAGE CONTACTS (3): COPPER ALLOY
 SPRING PLATE: STAINLESS STEEL
 LOCKING RING: PBT
2. FINISH:
 DIMMING CONTACTS (2 OR 4): NICKEL UNDERPLATE ENTIRE CONTACT
 0.127 μm MIN THICK. GOLD PLATE CONTACT PAD AREA (MATING FACE SIDE ONLY) 0.76 μm MIN THICK. MATTE TIN PLATE TAB ON BOTH SIDES
 0.30 μm MIN THICK.
 LINE VOLTAGE CONTACTS (3): TIN PLATE.
3. LINE VOLTAGE CONDUCTORS (3):
 14 AWG, 600V, 150°C RATED, COPPER 41/30 STRANDED
 PER UL STYLE AWM 3321.
4. MATING INTERFACE PER ANSI C136.41-2013.
5. OPTIONAL DIMMING CONTACTS (2) SUPPLIED.
6. DIMMING CONDUCTORS (2 OR 4):
 18 AWG, 600V, 150°C RATED, 16/30 STRANDED,
 PER UL STYLE AWM 3321.
7. LINE VOLTAGE CONDUCTORS (3):
 14 AWG, 600V, 105°C RATED, COPPER 41/30 STRANDED.
 PER UL STYLE AWM 1015.
8. DIMMING CONDUCTORS (2 OR 4):
 18 AWG, 600V, 105°C RATED, COPPER 16/30 STRANDED.
 PER UL STYLE AWM 1015.
9. MUST COMPLY WITH DIRECTIVE 2002/95/EC (ROHS)
10. LOCKING RING (REF P/N: 2333095-1) AND
 SPRING PLATE (REF P/N: 2333094-1) NOT ASSEMBLED,
 SHIPPED BULK PACKED
11. MUST BE USED WITH GASKET (REF P/N: 2332473-1) SOLD SEPARATELY

304.8	291.3	7 AND 8	4 5	2-2332966-4
304.8	291.3	7 AND 8	2	2-2332966-3
304.8	291.3	3 AND 6	4 5	2-2332966-2
304.8	291.3	3 AND 6	2	2-2332966-1
A	B	WIRE STYLE	QUANTITY OF DIMMING CONTACTS	PART NO.
WIRE LENGTH				

THIS DRAWING IS A CONTROLLED DOCUMENT.		DWN C. DAILY 15MAR2018	TE Connectivity	
		CHK E. HOWARD 15MAR2018		
DIMENSIONS: mm	TOLERANCES UNLESS OTHERWISE SPECIFIED:	APVD -	NAME RECEPTACLE ASSEMBLY, LUMAWISE ENDURANCE N TOOL-LESS ROTATABLE	
	0 PLC ±	PRODUCT SPEC 108-133114	SIZE A2	CAGE CODE 00779
	1 PLC ±0.2	APPLICATION SPEC 114-133114	DRAWING NO C-2332966	RESTRICTED TO -
MATERIAL	FINISH	WEIGHT -	SCALE 1:1	SHEET 1 OF 3
CUSTOMER DRAWING			REV B	

THIS DRAWING IS UNPUBLISHED. RELEASED FOR PUBLICATION 20
 © COPYRIGHT 20 BY - ALL RIGHTS RESERVED.

REVISIONS				
P	LTR	DESCRIPTION	DATE	APVD
-	-	SEE SHEET 1	-	-

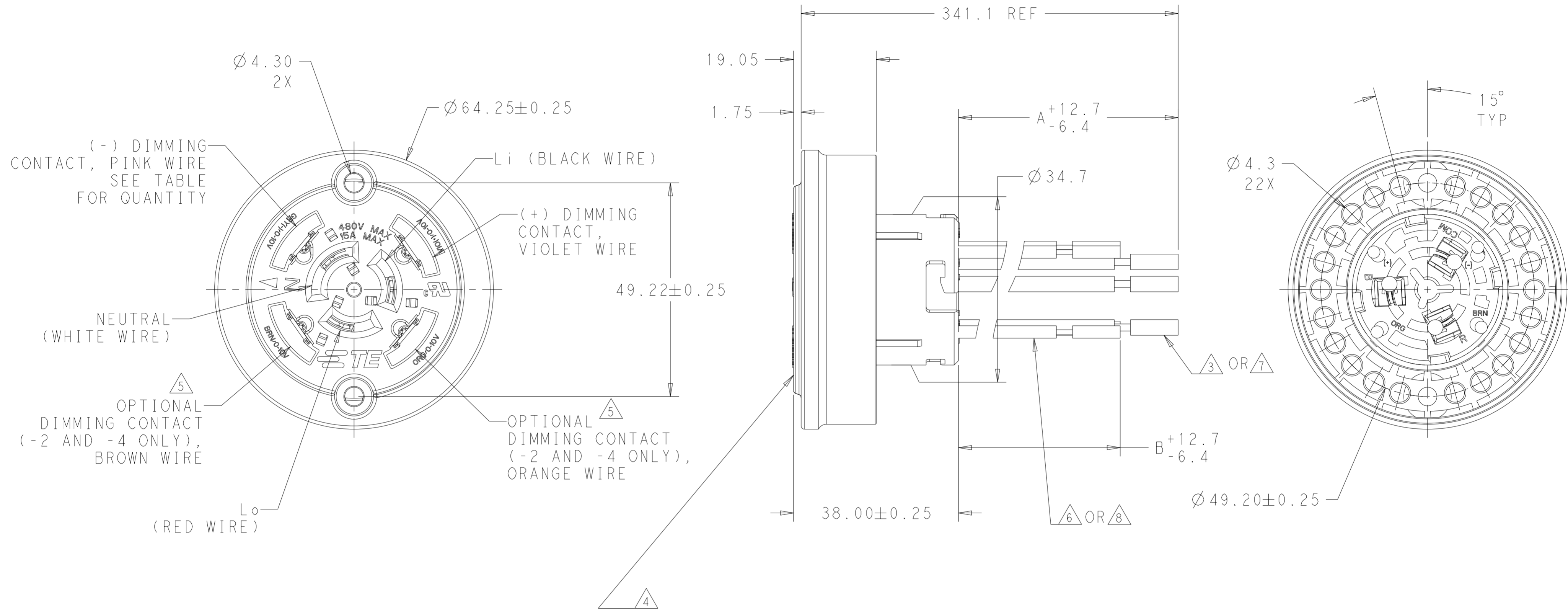

THIS DRAWING IS A CONTROLLED DOCUMENT.		DWN C. DAILY 15MAR2018	 TE Connectivity	
		CHK E. HOWARD 15MAR2018		
DIMENSIONS: mm		TOLERANCES UNLESS OTHERWISE SPECIFIED: 0 PLC ± 1 PLC ±0.2 2 PLC ±0.13 3 PLC ± 4 PLC ± ANGLES ±1° FINISH		NAME RECEPTACLE ASSEMBLY, LUMAWISE ENDURANCE N TOOL-LESS ROTATABLE
MATERIAL		APVD -	PRODUCT SPEC 108-133114	RESTRICTED TO
		APPLICATION SPEC 114-133114	SIZE A2	CAGE CODE 00779
		WEIGHT -	DRAWING NO C-2332966	SCALE 1:1
		CUSTOMER DRAWING	SHEET 2	OF 3
			REV B	