

Description

Single pole thermal circuit breaker with press-to-reset, tease-free, trip-free, snap action mechanism. Type 2-5000 is available with optional manual release (-H), type 2-5700 can be supplied as a push-push switch/circuit breaker (R-type TO CBE to EN 60934 in press-to-reset configuration; M-type when fitted with manual release -H; S-type with push-push operation). Fitted with flange or threadneck for panel mounting. Options include an additional unprotected circuit tap (-A3). Approved to CBE standard EN 60934 (IEC 60934).

Typical applications

Motors, transformers, solenoids, battery chargers, power supplies, appliances, machinery, extra low voltage systems.

Ordering information

Type No.

2-5000 flange mounting

2-5700 threadneck panel mounting

Threadneck design – type 2-5700 only

iG1 moulded threadneck 3/8"-27UNS-2A with metal hexnut and plastic knurled nut (hardware bulk shipped with 5 pcs plus)

iG2 moulded threadneck M12x1 with metal hexnut and plastic knurled nut (hardware bulk shipped with 5 pcs plus)

Terminal design

P10 blade terminals 6.3-0.8 mm (QC .250)

K10 screw terminals M4x6

Manual release (optional)

H manual release facility (type 2-5000 only)

DD push to release/push to reset (type 2-5700 only)

Current ratings

0.05...25 A

2-5700 -iG1 - P10 - DD - 8 A ordering example

Please be informed that we have minimum ordering quantities to be observed.

Preferred types

Preferred types	Standard current ratings (A)												
	1	2	3	4	5	6	8	10	12	15	16	20	25
2-5700-IG1-P10-	x	x	x	x	x	x	x	x	x	x	x	x	x
2-5700-IG1-P10-DD			x	x	x	x	x	x	x	x	x	x	x
2-5700-IG2-P10-			x	x	x	x	x	x	x	x	x	x	x
2-5700-IG2-P10-DD			x	x	x	x	x	x	x	x	x	x	x

Approvals

Authority	Standard	Rated voltage	Current ratings
VDE	IEC/EN 60934	AC 250 V DC 28 V	0.05 A...25 A 0.05 A...25 A
UL	UL 1077	AC 250 V DC 50 V	0.05 A...20 A 0.05 A...25 A
CSA	C22.2 No 235	AC 250 V DC 50 V	0.05 A...20 A 0.05 A...25 A
CQC	GB 17701	AC 250 V DC 28 V	0.05 A...25 A 0.05 A...25 A



Technical data

For further details please see: www.e-t-a.de/ti_e

Voltage rating	AC 250 V; DC 28 V (UL: AC 250 V; DC 50 V)	
Current rating range	0.05...25 A	
Typical life	AC 250 V / DC 28 V: 0.05...16 A 5,000 operations at 2 x I _N , inductive 17...25 A 5,000 operations at 2 x I _N , resistive	
Ambient temperature	-20...+60 °C (-4...+140 °F)	
Insulation co-ordination (IEC 60664 and 60664 A)	rated impulse withstand voltage 2.5 kV reinforced insulation in operating area	pollution degree 2
Dielectric strength (IEC 60664 and 60664A) operating area	test voltage AC 3,000 V	
Insulation resistance	> 100 MΩ (DC 500 V)	
Interrupting capacity I _{cn}	0.05...2.5 A 3...5 A 6...12 A 13...25 A	8 x I _N 20 x I _N 200 A 300 A (higher interrupting capacity available to special order)
Interrupting capacity (UL 1077)	I _N 0.05...20 A 0.05...25 A	U _N AC 250 V 2,000 A DC 50 V 2,500 A (higher values upon request)
Degree of protection (IEC 60529/DIN 40050)	operating area IP40 terminal area IP00	
Vibration	8 g (57-500 Hz) ± 0.61 mm (10-57 Hz), to IEC 60068-2-6, test Fc, 10 frequency cycles/axis	
Shock	25 g (11 ms) to IEC 60068-2-27, test Ea	
Corrosion	96 hours at 5 % salt mist, to IEC 60068-2-11, test Ka	
Humidity	240 hours at 95 % RH to IEC 60068-2-78, test Cab	
Mass	approx. 29 g	

Dimensions

2-5000-P10

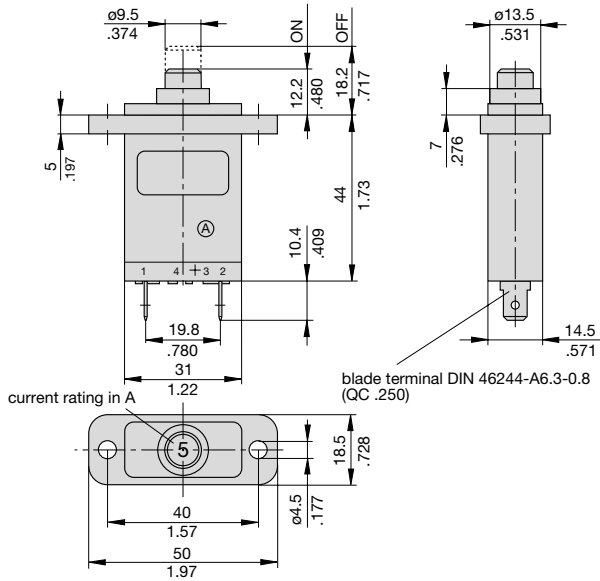

2-5700-P10

3/8

iG1=3/8-27UNS-2A tightening torque max. 1 Nm
iG2=M12x1 tightening torque max. 1.5 Nm

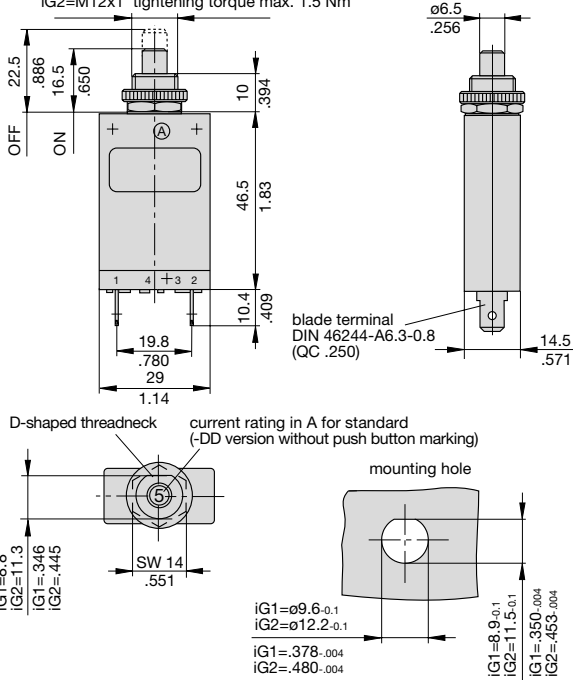

Installation drawings

2-5000-P10

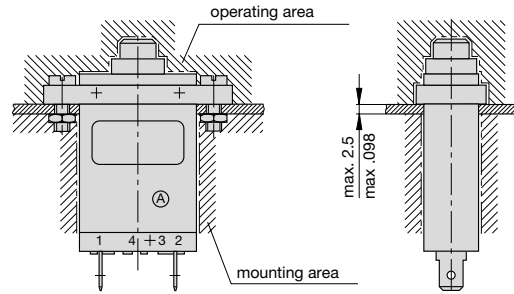

2-5700-P10

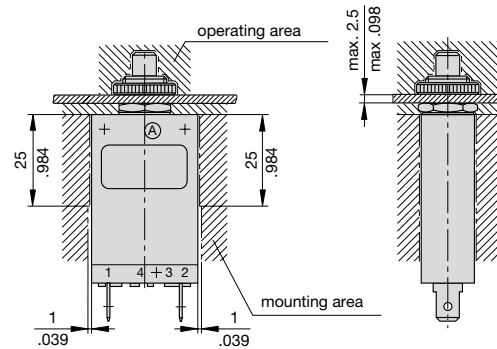

Standard current ratings and typical internal resistance values

Current rating (A)	Internal resistance (Ω)	Current rating (A)	Internal resistance (Ω)
0.05	280	3	0.1
0.08	100	3.5	0.06
0.1	110	4	0.06
0.2	29	4.5	0.05
0.3	14	5	0.05
0.4	7	6	0.02
0.5	4.9	7	0.02
0.6	3.4	8	0.02
0.7	2.5	10	< 0.02
0.8	1.8	12	< 0.02
1	1.2	13	< 0.02
1.2	0.8	15	< 0.02
1.5	0.6	16	< 0.02
1.8	0.4	20	< 0.02
2	0.3	22	< 0.02
2.5	0.2	25	< 0.02

Terminal design

-K10

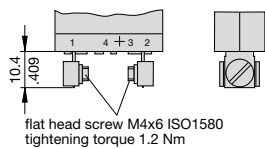

This is a metric design and millimeter dimensions take precedence (mm/inch)

Typical time/current characteristics at +23 °C/+73.4 °F

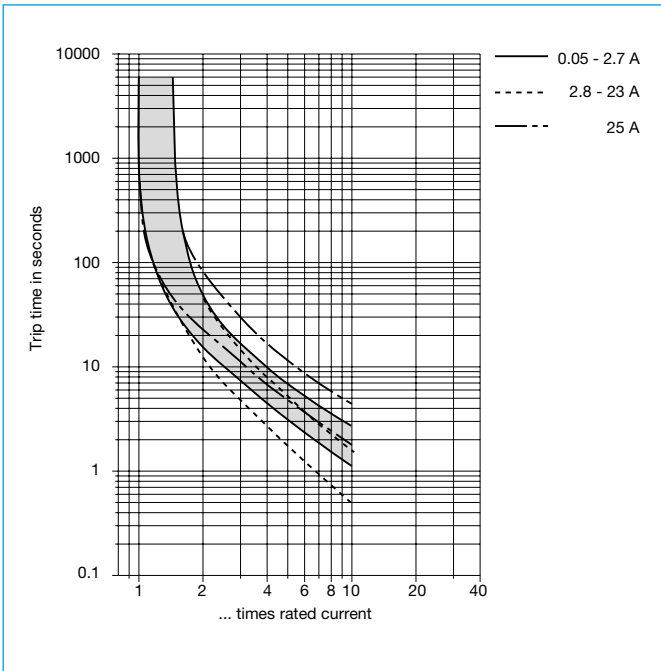

The time/current characteristic curve depends on the ambient temperature prevailing. In order to eliminate nuisance tripping, please multiply the circuit breaker current ratings by the derating factor shown below. See also section Technical information.

Ambient temperature °F	-4	+14	+32	+73.4	+104	+122	+140
°C	-20	-10	0	+23	+40	+50	+60
Derating factor	0.76	0.84	0.92	1	1.08	1.16	1.24

Internal connection diagrams

