

emFile

CPU-independent file system
for embedded applications

User Guide & Reference Manual

Document: UM02001
Software Version: 5.26.0
Revision: 0
Date: November 28, 2023



A product of SEGGER Microcontroller GmbH

www.segger.com

Disclaimer

The information written in this document is assumed to be accurate without guarantee. The information in this manual is subject to change for functional or performance improvements without notice. SEGGER Microcontroller GmbH (SEGGER) assumes no responsibility for any errors or omissions in this document. SEGGER disclaims any warranties or conditions, express, implied or statutory for the fitness of the product for a particular purpose. It is your sole responsibility to evaluate the fitness of the product for any specific use.

Copyright notice

You may not extract portions of this manual or modify the PDF file in any way without the prior written permission of SEGGER. The software described in this document is furnished under a license and may only be used or copied in accordance with the terms of such a license.

© 2002-2023 SEGGER Microcontroller GmbH, Monheim am Rhein / Germany

Trademarks

Names mentioned in this manual may be trademarks of their respective companies.

Brand and product names are trademarks or registered trademarks of their respective holders.

Contact address

SEGGER Microcontroller GmbH

Ecolab-Allee 5
D-40789 Monheim am Rhein

Germany

Tel. +49 2173-99312-0
Fax. +49 2173-99312-28
E-mail: support@segger.com*
Internet: www.segger.com

*By sending us an email your (personal) data will automatically be processed. For further information please refer to our privacy policy which is available at <https://www.segger.com/legal/privacy-policy/>.

Manual versions

This manual describes the current software version. If any error occurs, inform us and we will try to assist you as soon as possible. Contact us for further information on topics or routines not yet specified.

Print date: November 28, 2023

Software	Revision	Date	By	Description
5.26.0	0	231117	MD	<p>Added section for the Storage Image Creator utility.</p> <p>Added FS_GetFileSizeEx() function.</p> <p>Added FS_STORAGE_SyncEx() function.</p> <p>Added FS_STORAGE_FindVolumeByDevice() function.</p> <p>Added FS_STORAGE_FindVolumeByIndex() function.</p> <p>Added FS_STORAGE_FreeSectorsEx() function.</p> <p>Added FS_STORAGE_CleanEx() function.</p> <p>Added FS_STORAGE_CleanOneEx() function.</p> <p>Added FS_STORAGE_GetCleanCntEx() function.</p> <p>Added FS_STORAGE_GetSectorUsageEx() function.</p> <p>Added FS_STORAGE_RefreshSectorsEx() function.</p> <p>Added FS_STORAGE_SyncSectorsEx() function.</p> <p>Added FS_STORAGE_Mount() function.</p> <p>Added FS_STORAGE_MountEx() function.</p> <p>Added FS_STORAGE_SetAutoMountType() function.</p> <p>Added FS_STORAGE_GetAutoMountType() function.</p> <p>Added FS_STORAGE_GetMountType() function.</p> <p>Added FS_STORAGE_SetAutoMountTypeEx() function.</p> <p>Added FS_STORAGE_GetAutoMountTypeEx() function.</p> <p>Added FS_STORAGE_GetMountTypeEx() function.</p> <p>Added FS_STORAGE_SUPPORT_MOUNT configuration define.</p>
5.24.0	0	230828	MD	<p>Updated section about Encryption usage.</p> <p>Updated the list of supported NAND flash devices.</p> <p>Added FS_MMC_CM_ReadSectors() function.</p> <p>Added FS_MMC_CM_WriteSectors() function.</p> <p>Added FS_LOGVOL_SUPPORT_CLEAN configuration define.</p> <p>Added FS_LOGVOL_SUPPORT_TRIM configuration define.</p> <p>Added FS_MMC_CM_ReadCSD() function.</p> <p>Added section for the File Disk driver.</p> <p>Added FS_NOR_OPTIMIZE_EMPTY_CHECK configuration define.</p> <p>Added exportimage command to NOR Image Creator.</p> <p>Updated the list of supported NOR flash devices.</p> <p>Updated the list of supported FRAM devices.</p> <p>Added exportfolder command to NAND Image Creator.</p> <p>Added /R option to rd command of the NAND Image Creator.</p> <p>Added /S option to addfolder command of the NAND Image Creator.</p>
5.22.0	0	230216	MD	<p>Added section for Universal RAM Disk driver</p> <p>Updated the list of supported NAND flash devices.</p> <p>Updated the list of supported NOR flash devices.</p> <p>Added FS_NOR_DMB() configuration define.</p> <p>Added FS_NOR_REVERSE_ENDIANNESS configuration define.</p> <p>Added FS_STORAGE_FillSectors() API function.</p> <p>Added FS_STORAGE_FillSectorsEx() API function.</p> <p>Added FS_MMC_CM_ReadGeneral() API function.</p> <p>Added FS_MMC_CM_WriteGeneral() API function.</p>
5.20.0	0	221114	MD	<p>Updated the list of supported NOR flash devices.</p> <p>Added section for partitioning functions.</p> <p>Updated the list of supported NAND flash devices.</p> <p>Added FS_FGets() function.</p> <p>Added FS_CreateGPT() function.</p> <p>Added FS_SUPPORT_GPT configuration define.</p> <p>Added FS_GetPartitioningScheme() function.</p> <p>Added FS_GetGPTInfo() function.</p> <p>Added FS_GPT_INFO structure.</p> <p>Added FS_GetPartitionInfoGPT() function.</p> <p>Added FS_PARTITION_INFO_GPT structure.</p> <p>Renamed FS_GetPartitionInfo() function to FS_GetPartitionInfoMBR()</p> <p>Renamed FS_PARTITION_INFO structure to FS_PARTITION_INFO_MBR.</p> <p>Added FS_SUPPORT_SECTOR_BUFFER_BURST configuration define.</p> <p>Added FS_MMC_DISABLE_DAT3_PULLUP configuration define.</p> <p>Added missing configuration defines for Card Mode MMC/SD driver.</p>

Software	Revision	Date	By	Description
5.18.0	0	220727	MD	Added FS_MMC_CM_AllowCacheActivation() function. Added FS_NOR_SPIFI_AllowDTRMode() function. Added FS_NOR_HW_TYPE_SPIFI_MAP_EX, FS_NOR_HW_TYPE_SPIFI_MAP_EX, FS_NOR_HW_TYPE_SPIFI_READ_EX, FS_NOR_HW_TYPE_SPIFI_WRITE_EX and FS_NOR_HW_TYPE_SPIFI_POLL_EX functions. Added FS_NOR_SPIFI_AllowOctalMode() function. Updated the list of supported NOR flash devices.
5.16.2	0	220725	MD	Changed the name of BigFile component to BigFAT.
5.16.0	0	220428	MD	Added sample for disk checking in the background. Added FS_Fputs() function. Added FS_NAND_UNI_SetMaxPageSize() function. Added FS_NAND_UNI_SetMaxSpareAreaSize() function. Added FS_FPrintf() function. Added FS_OPTIMIZATION_TYPE configuration define. Added extended the Storage layer API. Updated the list of supported NAND flash devices. Added FS_NOR_ErasePhySector() function. Added FS_NOR_WriteOff() function. Added FS_NOR_OPTIMIZE_DATA_WRITE configuration define. Added FS_NOR_SUPPORT_TRIM configuration define.
5.14.0	0	220307	MD	Added FS_NOR_HW_TYPE_SPI_READ_EX and FS_NOR_HW_TYPE_SPI_WRITE_EX functions. Added FS_FAT_CHECK_UNUSED_DIR_ENTRIES configuration define. Added FS_BIGFILE_CheckDisk() function. Updated the list of supported NOR flash devices. Added FS_NAND_2048X8_SetDeviceList() function. Added FS_MMC_GetCardInfo() function. Updated the list of supported NAND flash devices. Added FS_JOURNAL_OPTIMIZE_SPACE_USAGE configuration define. Added FS_NOR_SUPPORT_FORMAT configuration define.
5.12.0	0	211130	MD	Added FS_FAT_GetLFNConverter() function. Updated the list of features. Added FS_GetAutoMount() function. Added FS_FAT_GetConfig() function. Added FS_EFS_GetConfig() function. Added FS_NOR_SPIFI_ExecCmd() function.
5.10.0	0	210824	MD	Updated the list of supported NAND flash devices. Added setnumworkblocks command to NOR Image Creator.
5.8.1	0	210618	MD	Added FS_NAND_QSPI_SetDeviceList() function. Added information about the compile time and runtime configuration of the NAND physical layers. Added information about resource usage of NAND physical layers.
5.8.0	0	210517	MD	Added FS_CACHE_GetType() function. Added FS_NAND_UNI_GetBlockInfoEx() function. Added FS_NAND_ONFI_SetDeviceList() function. Updated the list of supported NOR flash devices. Updated the list of supported NAND flash devices. Added information about the compile time configuration of the NOR physical layers. Added information about creating a custom device or logical driver. Updated the list of file system configuration defines.
5.6.0	0	210127	MD	Added FS_NOR_BM_Mount() function. Added FS_MMC_CM_SetDriverStrength() function. Added information about the compile time configuration of the Block Map NOR driver. Added information about the compile time configuration of the Sector Map NOR driver. Updated the list of supported NOR flash devices. Added FS_NOR_BM_EnableECC() function. Added FS_NOR_BM_DisableECC() function. Added FS_NOR_BM_SetECCHook() function. Added FS_NOR_BM_IsECCEnabled() function. Added FS_NOR_ECC_HOOK structure. Added FS_NOR_ECC_HOOK_CALC function. Added FS_NOR_ECC_HOOK_APPLY function. Improved the section about the RAM usage of the file system.
5.4.0	0	201029	MD	Added FS_GetVolumeAlias() function. Added FS_NOR_SFDP_Configure() function.

Software	Revision	Date	By	Description
				Added FS_MMC_CM_AllowAccessModeDDR50() function. Added FS_MMC_CM_AllowAccessModeHS200() function. Added FS_MMC_CM_AllowAccessModeHS400() function. Added FS_MMC_CM_AllowAccessModeHS_DDR() function. Added FS_MMC_CM_AllowAccessModeSDR104() function. Added FS_MMC_CM_AllowAccessModeSDR50() function. Added FS_MMC_CM_AllowVoltageLevel1V8() function. Added FS_MMC_CM_SetHS200Tuning() function. Added FS_MMC_CM_SetSDR104Tuning() function. Added FS_MMC_CM_SetSDR50Tuning() function. Added information about the compile time configuration of the Card Mode MMC/SD driver.
5.2.0	1	200630	MD	Added FS_NAND_UNI_Mount() function.
5.2.0	0	200527	MD	Improved wording of the FAQs chapter. Added description of the BigFileMerger utility. Added FS_NOR_BM_SetInvalidSectorError() function.
5.1.0	1	200411	MD	Updated the resource usage of EFS.
5.1.0	0	200504	MD	Added FS_GetMountType() function. Added FS_NOR_SPIFI_SetSectorSize() function. Updated the list of supported NOR flash devices. Added FS_EFS_SUPPORT_FREE_CLUSTER_CACHE configuration define. Added FS_SUPPORT_SECTOR_BUFFER_CACHE configuration define. Added FS_GetMemInfo() function. Added more information about the fail-safety of the NOR drivers. Added compile time configuration information for the Block Map NOR driver.
5.0.1	1	200317	MD	Corrected a sample.
5.0.1	0	200316	MD	Corrected structure member names.
5.0.0	0	200301	MD	Reworked version of the manual.

About this document

Assumptions

This document assumes that you already have a solid knowledge of the following:

- The software tools used for building your application (assembler, linker, C compiler).
- The C programming language.
- The target processor.
- DOS command line.

If you feel that your knowledge of C is not sufficient, we recommend *The C Programming Language* by Kernighan and Ritchie (ISBN 0--13--1103628), which describes the standard in C programming and, in newer editions, also covers the ANSI C standard.

How to use this manual

This manual explains all the functions and macros that the product offers. It assumes you have a working knowledge of the C language. Knowledge of assembly programming is not required.

Typographic conventions for syntax

This manual uses the following typographic conventions:

Style	Used for
Body	Body text.
Keyword	Text that you enter at the command prompt or that appears on the display (that is system functions, file- or pathnames).
Parameter	Parameters in API functions.
Sample	Sample code in program examples.
Sample comment	Comments in program examples.
Reference	Reference to chapters, sections, tables and figures or other documents.
GUIElement	Buttons, dialog boxes, menu names, menu commands.
Emphasis	Very important sections.

Table of contents

1	Introduction to emFile	34
1.1	What is emFile	35
1.2	Features	36
1.3	Basic concepts	37
1.3.1	emFile structure	37
1.3.1.1	API layer	38
1.3.1.2	File system layer	38
1.3.1.3	Storage layer	38
1.3.1.4	Driver layer	38
1.3.1.5	Hardware layer	38
1.3.2	Choice of file system type: FAT vs. EFS	38
1.3.3	Fail safety	39
1.3.4	Wear leveling	39
1.4	Implementation notes	40
1.4.1	File system configuration	40
1.4.2	Runtime memory requirements	40
1.4.3	Initializing the file system	40
1.4.4	Development environment (compiler)	40
2	Getting started	41
2.1	Package content and installation	42
2.2	Using the Windows sample application	43
2.2.1	Building the sample application	43
2.2.2	Overview of the sample application	43
2.2.3	Stepping through the sample application	44
2.3	Further source code examples	49
2.4	Recommended project structure	50
3	Running emFile on target hardware	51
3.1	Integrating emFile	52
3.2	Procedure to follow	53
3.3	Step 1: Creating a simple project without emFile	54
3.4	Step 2: Adding emFile to the start project	55
3.4.1	Configuring the include path	55
3.4.2	Select the start application	56
3.4.3	Build the project and test it	56
3.5	Step 3: Adding the device driver	57
3.5.1	Adding the device driver source to project	57
3.5.2	Adding hardware routines to project	58

3.6	Step 4: Activating the driver	59
3.6.1	Modifying the runtime configuration	59
3.7	Step 5: Adjusting the RAM usage	62
4	API functions	63
4.1	General information	64
4.1.1	Volume, file and directory names	64
4.2	API function overview	65
4.3	File system control functions	73
4.3.1	FS_Init()	74
4.3.2	FS_DeInit()	75
4.3.3	FS_Mount()	76
4.3.4	FS_MountEx()	77
4.3.5	FS_SetAutoMount()	78
4.3.6	FS_Sync()	79
4.3.7	FS_Unmount()	80
4.3.8	FS_UnmountForced()	81
4.3.9	Volume mounting modes	82
4.4	File system configuration functions	83
4.4.1	FS_AddDevice()	84
4.4.2	FS_AddPhysDevice()	85
4.4.3	FS_AssignMemory()	86
4.4.4	FS_ConfigFileBufferDefault()	87
4.4.5	FS_LOGVOL_Create()	88
4.4.6	FS_LOGVOL_AddDevice()	89
4.4.7	FS_SetFileBufferFlags()	90
4.4.8	FS_SetFileBufferFlagsEx()	91
4.4.9	FS_SetFileWriteMode()	92
4.4.10	FS_SetFileWriteModeEx()	93
4.4.11	FS_SetMemHandler()	94
4.4.12	FS_SetMaxSectorSize()	95
4.4.13	FS_MEM_ALLOC_CALLBACK	96
4.4.14	FS_MEM_FREE_CALLBACK	97
4.4.15	FS_WRITEMODE	98
4.5	File access functions	99
4.5.1	FS_FClose()	100
4.5.2	FS_FGets()	101
4.5.3	FS_FOpen()	102
4.5.4	FS_FOpenEx()	104
4.5.5	FS_FPrintf()	105
4.5.6	FS_FPuts()	106
4.5.7	FS_FRead()	107
4.5.8	FS_FSeek()	108
4.5.9	FS_FWrite()	110
4.5.10	FS_FTell()	111
4.5.11	FS_GetFileSize()	112
4.5.12	FS_GetFileSizeEx()	113
4.5.13	FS_Read()	114
4.5.14	FS_SetEndOfFile()	115
4.5.15	FS_SetFileSize()	116
4.5.16	FS_SyncFile()	117
4.5.17	FS_Truncate()	118
4.5.18	FS_Verify()	119
4.5.19	FS_Write()	120
4.5.20	File positioning reference	121
4.6	Operations on files	122
4.6.1	FS_CopyFile()	123
4.6.2	FS_CopyFileEx()	124
4.6.3	FS_GetFileAttributes()	125

4.6.4	FS_GetFileInfo()	126
4.6.5	FS_GetFileTime()	127
4.6.6	FS_GetFileTimeEx()	128
4.6.7	FS_ModifyFileAttributes()	129
4.6.8	FS_Move()	131
4.6.9	FS_Remove()	133
4.6.10	FS_Rename()	134
4.6.11	FS_SetFileAttributes()	135
4.6.12	FS_SetFileBuffer()	136
4.6.13	FS_SetFileTime()	138
4.6.14	FS_SetFileTimeEx()	139
4.6.15	FS_WipeFile()	140
4.6.16	File attributes	141
4.6.17	FS_FILE_INFO	142
4.6.18	File time types	143
4.7	Directory functions	144
4.7.1	FS_CreateDir()	145
4.7.2	FS_DeleteDir()	146
4.7.3	FS_FindClose()	147
4.7.4	FS_FindFirstFile()	148
4.7.5	FS_FindNextFile()	150
4.7.6	FS_FindNextFileEx()	151
4.7.7	FS_MkDir()	152
4.7.8	FS_RmDir()	153
4.7.9	FS_FIND_DATA	154
4.8	Formatting functions	155
4.8.1	FS_Format()	156
4.8.2	FS_FormatLLIfRequired()	157
4.8.3	FS_FormatLow()	158
4.8.4	FS_IsHLFormatted()	159
4.8.5	FS_IsLLFormatted()	160
4.8.6	FS_FORMAT_INFO	161
4.9	Partitioning functions	162
4.9.1	FS_CreateGPT()	163
4.9.2	FS_CreateMBR()	166
4.9.3	FS_GetGPTInfo()	168
4.9.4	FS_GetPartitionInfoMBR()	170
4.9.5	FS_GetPartitionInfoGPT()	172
4.9.6	FS_GetPartitioningScheme()	174
4.9.7	FS_GPT_INFO	175
4.9.8	FS_PARTITION_INFO_MBR	176
4.9.9	FS_PARTITION_INFO_GPT	177
4.9.10	Partitioning schemes	178
4.10	File system structure checking	179
4.10.1	FS_CheckAT()	180
4.10.2	FS_CheckDir()	181
4.10.3	FS_CheckDisk()	182
4.10.4	FS_CheckDisk_ErrCode2Text()	185
4.10.5	FS_InitCheck()	186
4.11	File system extended functions	191
4.11.1	FS_ConfigEOFErrorSuppression()	192
4.11.2	FS_ConfigPOSIXSupport()	193
4.11.3	FS_ConfigWriteVerification()	194
4.11.4	FS_FileTimeToTimeStamp()	195
4.11.5	FS_FreeSectors()	196
4.11.6	FS_GetAutoMount()	197
4.11.7	FS_GetFileId()	198
4.11.8	FS_GetFileWriteMode()	199
4.11.9	FS_GetFileWriteModeEx()	200
4.11.10	FS_GetFSType()	201

4.11.11	FS_GetMaxSectorSize()	202
4.11.12	FS_GetMemInfo()	203
4.11.13	FS_GetMountType()	204
4.11.14	FS_GetNumFilesOpen()	205
4.11.15	FS_GetNumFilesOpenEx()	206
4.11.16	FS_GetNumVolumes()	207
4.11.17	FS_GetVolumeAlias()	208
4.11.18	FS_GetVolumeFreeSpace()	209
4.11.19	FS_GetVolumeFreeSpaceFirst()	210
4.11.20	FS_GetVolumeFreeSpaceKB()	212
4.11.21	FS_GetVolumeFreeSpaceNext()	213
4.11.22	FS_GetVolumeInfo()	214
4.11.23	FS_GetVolumeInfoEx()	216
4.11.24	FS_GetVolumeLabel()	218
4.11.25	FS_GetVolumeName()	219
4.11.26	FS_GetVolumeSize()	220
4.11.27	FS_GetVolumeSizeKB()	221
4.11.28	FS_GetVolumeStatus()	222
4.11.29	FS_IsVolumeMounted()	223
4.11.30	FS_Lock()	224
4.11.31	FS_LockVolume()	225
4.11.32	FS_SetBusyLEDCallback()	227
4.11.33	FS_SetCharSetType()	228
4.11.34	FS_SetFSType()	229
4.11.35	FS_SetMemCheckCallback()	230
4.11.36	FS_SetTimeDateCallback()	231
4.11.37	FS_SetVolumeAlias()	232
4.11.38	FS_SetVolumeLabel()	233
4.11.39	FS_TimeStampToFileTime()	234
4.11.40	FS_Unlock()	235
4.11.41	FS_UnlockVolume()	236
4.11.42	Disk checking error codes	237
4.11.43	Disk checking return values	238
4.11.44	Disk checking action codes	239
4.11.45	File system types	240
4.11.46	Format types	241
4.11.47	FS_BUSY_LED_CALLBACK	242
4.11.48	FS_CHECKDISK_ON_ERROR_CALLBACK	243
4.11.49	FS_CHS_ADDR	244
4.11.50	FS_DISK_INFO	245
4.11.51	FS_FILETIME	247
4.11.52	FS_FREE_SPACE_DATA	248
4.11.53	FS_MEM_CHECK_CALLBACK	249
4.11.54	FS_MEM_INFO	250
4.11.55	FS_TIME_DATE_CALLBACK	251
4.11.56	Volume information flags	252
4.12	Storage layer functions	253
4.12.1	FS_STORAGE_Clean()	254
4.12.2	FS_STORAGE_CleanEx()	256
4.12.3	FS_STORAGE_CleanOne()	257
4.12.4	FS_STORAGE_CleanOneEx()	258
4.12.5	FS_STORAGE_DeInit()	259
4.12.6	FS_STORAGE_FillSectors()	260
4.12.7	FS_STORAGE_FillSectorsEx()	261
4.12.8	FS_STORAGE_FindVolume()	262
4.12.9	FS_STORAGE_FindVolumeByDevice()	263
4.12.10	FS_STORAGE_FindVolumeByIndex()	264
4.12.11	FS_STORAGE_FormatLowEx()	265
4.12.12	FS_STORAGE_FreeSectors()	266
4.12.13	FS_STORAGE_FreeSectorsEx()	267

4.12.14	FS_STORAGE_GetAutoMountType()	268
4.12.15	FS_STORAGE_GetAutoMountTypeEx()	269
4.12.16	FS_STORAGE_GetCleanCnt()	270
4.12.17	FS_STORAGE_GetCleanCntEx()	271
4.12.18	FS_STORAGE_GetCounters()	272
4.12.19	FS_STORAGE_GetDeviceInfo()	273
4.12.20	FS_STORAGE_GetDeviceInfoEx()	274
4.12.21	FS_STORAGE_GetMountType()	275
4.12.22	FS_STORAGE_GetMountTypeEx()	276
4.12.23	FS_STORAGE_GetSectorUsage()	277
4.12.24	FS_STORAGE_GetSectorUsageEx()	278
4.12.25	FS_STORAGE_GetVolumeStatusEx()	279
4.12.26	FS_STORAGE_Init()	280
4.12.27	FS_STORAGE_IsLLFormattedEx()	281
4.12.28	FS_STORAGE_Mount()	282
4.12.29	FS_STORAGE_MountEx()	283
4.12.30	FS_STORAGE_ReadSector()	284
4.12.31	FS_STORAGE_ReadSectorEx()	285
4.12.32	FS_STORAGE_ReadSectors()	286
4.12.33	FS_STORAGE_ReadSectorsEx()	287
4.12.34	FS_STORAGE_RefreshSectors()	288
4.12.35	FS_STORAGE_RefreshSectorsEx()	289
4.12.36	FS_STORAGE_ResetCounters()	290
4.12.37	FS_STORAGE_SetAutoMountType()	291
4.12.38	FS_STORAGE_SetAutoMountTypeEx()	292
4.12.39	FS_STORAGE_SetOnDeviceActivityCallback()	293
4.12.40	FS_STORAGE_Sync()	294
4.12.41	FS_STORAGE_SyncEx()	295
4.12.42	FS_STORAGE_SyncSectors()	296
4.12.43	FS_STORAGE_SyncSectorsEx()	297
4.12.44	FS_STORAGE_Unmount()	298
4.12.45	FS_STORAGE_UnmountEx()	299
4.12.46	FS_STORAGE_UnmountForced()	300
4.12.47	FS_STORAGE_UnmountForcedEx()	301
4.12.48	FS_STORAGE_WriteSector()	302
4.12.49	FS_STORAGE_WriteSectorEx()	303
4.12.50	FS_STORAGE_WriteSectors()	304
4.12.51	FS_STORAGE_WriteSectorsEx()	305
4.12.52	FS_DEV_INFO	306
4.12.53	FS_ON_DEVICE_ACTIVITY_CALLBACK	307
4.12.54	FS_STORAGE_COUNTERS	308
4.12.55	Sector data type	309
4.12.56	Transfer direction	310
4.13	FAT related functions	311
4.13.1	FS_FAT_ConfigDirtyFlagUpdate()	312
4.13.2	FS_FAT_ConfigFATCopyMaintenance()	313
4.13.3	FS_FAT_ConfigFSInfoSectorUse()	314
4.13.4	FS_FAT_ConfigROFileMovePermission()	315
4.13.5	FS_FAT_DisableLFN()	316
4.13.6	FS_FAT_FormatSD()	317
4.13.7	FS_FAT_GetConfig()	318
4.13.8	FS_FAT_GetLFNConverter()	319
4.13.9	FS_FAT_GrowRootDir()	320
4.13.10	FS_FAT_SetLFNConverter()	321
4.13.11	FS_FAT_SupportLFN()	322
4.13.12	FS_FAT_CONFIG	323
4.14	EFS related functions	324
4.14.1	FS_EFS_ConfigCaseSensitivity()	325
4.14.2	FS_EFS_ConfigStatusSectorSupport()	326
4.14.3	FS_EFS_GetConfig()	327

4.14.4	FS_EFS_SetFileNameConverter()	328
4.14.5	FS_EFS_CONFIG	329
4.15	Error-handling functions	330
4.15.1	FS_ClearErr()	331
4.15.2	FS_ErrorNo2Text()	332
4.15.3	FS_FEOF()	333
4.15.4	FS_FError()	334
4.15.5	Error codes	335
4.16	Configuration checking functions	339
4.16.1	FS_CONF_GetDebugLevel()	340
4.16.2	FS_CONF_GetDirectoryDelimiter()	341
4.16.3	FS_CONF_GetMaxPath()	342
4.16.4	FS_CONF_GetNumVolumes()	343
4.16.5	FS_CONF_GetOSLocking()	344
4.16.6	FS_CONF_IsCacheSupported()	345
4.16.7	FS_CONF_IsDeInitSupported()	346
4.16.8	FS_CONF_IsEFSSupported()	347
4.16.9	FS_CONF_IsEncryptionSupported()	348
4.16.10	FS_CONF_IsFATSupported()	349
4.16.11	FS_CONF_IsFreeSectorSupported()	350
4.16.12	FS_CONF_IsJournalSupported()	351
4.16.13	FS_CONF_IsTrialVersion()	352
4.16.14	FS_GetVersion()	353
4.17	Obsolete functions	354
4.17.1	FS_AddOnExitHandler()	355
4.17.2	FS_CloseDir()	356
4.17.3	FS_ConfigOnWriteDirUpdate()	357
4.17.4	FS_DirEnt2Attr()	358
4.17.5	FS_DirEnt2Name()	359
4.17.6	FS_DirEnt2Size()	360
4.17.7	FS_DirEnt2Time()	361
4.17.8	FS_GetNumFiles()	362
4.17.9	FS_OpenDir()	363
4.17.10	FS_ReadDir()	364
4.17.11	FS_RewindDir()	365
5	Caching and buffering	366
5.1	Sector cache	367
5.1.1	Write cache and journaling	367
5.1.2	Types of caches	367
5.1.2.1	FS_CACHE_ALL	367
5.1.2.2	FS_CACHE_MAN	367
5.1.2.3	FS_CACHE_RW	367
5.1.2.4	FS_CACHE_RW_QUOTA	367
5.1.2.5	FS_CACHE_MULTI_WAY	368
5.1.3	Cache API functions	369
5.1.3.1	FS_AssignCache()	370
5.1.3.2	FS_CACHE_Clean()	372
5.1.3.3	FS_CACHE_GetNumSectors()	373
5.1.3.4	FS_CACHE_GetType()	374
5.1.3.5	FS_CACHE_Invalidate()	375
5.1.3.6	FS_CACHE_SetAssocLevel()	376
5.1.3.7	FS_CACHE_SetMode()	377
5.1.3.8	FS_CACHE_SetQuota()	379
5.1.3.9	Sector cache types	381
5.1.3.10	Sector cache modes	382
5.1.3.11	Sector cache size	383
5.1.3.12	Sector data flags	384
5.1.4	Performance and resource usage	384

5.1.4.1	Performance	384
5.2	File buffer	388
6	Device drivers	389
6.1	General information	390
6.1.1	Hardware layer	390
6.2	RAM Disk driver	393
6.2.1	General information	393
6.2.1.1	Theory of operation	393
6.2.1.2	Fail-safe operation	393
6.2.1.3	Wear leveling	393
6.2.1.4	Formatting	393
6.2.2	System RAM Disk driver	394
6.2.2.1	Supported hardware	394
6.2.2.2	Configuring the driver	394
6.2.2.2.1	Compile-time configuration	395
6.2.2.2.2	Runtime configuration	395
6.2.2.3	Performance and resource usage	397
6.2.2.3.1	ROM usage	397
6.2.2.3.2	Static RAM usage	397
6.2.2.3.3	Dynamic RAM usage	397
6.2.2.3.4	Performance	397
6.2.3	Universal RAM Disk driver	398
6.2.3.1	Supported hardware	398
6.2.3.2	Configuring the driver	398
6.2.3.2.1	Compile-time configuration	401
6.2.3.2.2	Runtime configuration	402
6.2.3.3	Additional driver functions	407
6.2.3.3.1	FS_RAMDISK_UNI_GetDiskInfo()	408
6.2.3.3.2	FS_RAMDISK_UNI_ReadOff()	409
6.2.3.3.3	FS_RAMDISK_UNI_WriteOff()	410
6.2.3.3.4	FS_RAMDISK_UNI_DISK_INFO	411
6.2.3.4	Performance and resource usage	412
6.2.3.4.1	ROM usage	412
6.2.3.4.2	Static RAM usage	412
6.2.3.4.3	Dynamic RAM usage	412
6.2.3.4.4	Performance	412
6.2.4	RAMDISK physical layer	413
6.2.4.1	General information	413
6.2.4.2	I2C physical layer	414
6.2.4.2.1	Runtime configuration	414
6.2.4.3	SPI physical layer	418
6.2.4.3.1	Runtime configuration	418
6.2.4.4	System physical layer	426
6.2.4.4.1	Runtime configuration	426
6.2.4.5	Physical layer API	428
6.2.4.5.1	FS_RAMDISK_PHY_TYPE	429
6.2.4.5.2	FS_RAMDISK_PHY_TYPE_INIT_GET_DEVICE_INFO	430
6.2.4.5.3	FS_RAMDISK_PHY_TYPE_READ_OFF	431
6.2.4.5.4	FS_RAMDISK_PHY_TYPE_WRITE_OFF	432
6.2.4.5.5	FS_RAMDISK_PHY_TYPE_DEINIT	433
6.2.4.5.6	FS_RAMDISK_DEVICE_INFO	434
6.2.4.6	Resource usage	435
6.2.4.6.1	ROM usage	435
6.2.4.6.2	Static RAM usage	435
6.2.4.6.3	Dynamic RAM usage	435
6.2.5	RAMDISK hardware layer	436
6.2.5.1	General information	436
6.2.5.2	Hardware layer API - FS_RAMDISK_HW_TYPE_I2C	437

6.2.5.2.1	FS_RAMDISK_HW_TYPE_I2C	438
6.2.5.2.2	FS_RAMDISK_HW_TYPE_I2C_INIT	439
6.2.5.2.3	FS_RAMDISK_HW_TYPE_I2C_START	440
6.2.5.2.4	FS_RAMDISK_HW_TYPE_I2C_STOP	441
6.2.5.2.5	FS_RAMDISK_HW_TYPE_I2C_READ	442
6.2.5.2.6	FS_RAMDISK_HW_TYPE_I2C_WRITE	443
6.2.5.2.7	Sample implementation	444
6.2.5.3	Hardware layer API - FS_RAMDISK_HW_TYPE_SPI	452
6.2.5.3.1	FS_RAMDISK_HW_TYPE_SPI	453
6.2.5.3.2	FS_RAMDISK_HW_TYPE_SPI_INIT	454
6.2.5.3.3	FS_RAMDISK_HW_TYPE_SPI_UNMAP	455
6.2.5.3.4	FS_RAMDISK_HW_TYPE_SPI_MAP	456
6.2.5.3.5	FS_RAMDISK_HW_TYPE_SPI_CONTROL	457
6.2.5.3.6	FS_RAMDISK_HW_TYPE_SPI_READ	458
6.2.5.3.7	FS_RAMDISK_HW_TYPE_SPI_WRITE	459
6.2.5.3.8	FS_RAMDISK_HW_TYPE_SPI_LOCK	460
6.2.5.3.9	FS_RAMDISK_HW_TYPE_SPI_UNLOCK	461
6.2.5.3.10	Sample implementation	462
6.3	NAND flash driver	481
6.3.1	General information	481
6.3.1.1	Selecting the correct NAND driver	481
6.3.1.2	Multiple driver configurations	481
6.3.1.3	Software structure	481
6.3.1.4	Bad block management	481
6.3.1.5	Garbage collection	482
6.3.1.6	Fail-safe operation	482
6.3.1.7	Wear leveling	483
6.3.1.8	Read disturb errors	483
6.3.1.9	Low-level format	483
6.3.1.10	NAND flash organization	483
6.3.1.11	Pin description - parallel NAND flash device	484
6.3.1.12	Pin description - DataFlash device	485
6.3.2	SLC1 NAND driver	486
6.3.2.1	Supported hardware	486
6.3.2.1.1	Tested and compatible NAND flash devices	486
6.3.2.2	Theory of operation	488
6.3.2.3	Error correction using ECC	489
6.3.2.4	Partial write operations	489
6.3.2.5	Configuring the driver	489
6.3.2.5.1	Compile time configuration	489
6.3.2.5.2	Runtime configuration	491
6.3.2.6	Additional driver functions	504
6.3.2.6.1	FS_NAND_Clean()	505
6.3.2.6.2	FS_NAND_EraseBlock()	506
6.3.2.6.3	FS_NAND_EraseFlash()	507
6.3.2.6.4	FS_NAND_FormatLow()	508
6.3.2.6.5	FS_NAND_GetBlockInfo()	509
6.3.2.6.6	FS_NAND_GetDiskInfo()	510
6.3.2.6.7	FS_NAND_GetStatCounters()	512
6.3.2.6.8	FS_NAND_IsBlockBad()	513
6.3.2.6.9	FS_NAND_IsLLFormatted()	514
6.3.2.6.10	FS_NAND_ReadPageRaw()	515
6.3.2.6.11	FS_NAND_ReadPhySector()	516
6.3.2.6.12	FS_NAND_ResetStatCounters()	517
6.3.2.6.13	FS_NAND_TestBlock()	518
6.3.2.6.14	FS_NAND_WritePage()	520
6.3.2.6.15	FS_NAND_WritePageRaw()	521
6.3.2.6.16	FS_NAND_DISK_INFO	522
6.3.2.6.17	FS_NAND_BLOCK_INFO	524
6.3.2.7	Performance and resource usage	525

6.3.2.7.1	ROM usage	525
6.3.2.7.2	Static RAM usage	525
6.3.2.7.3	Dynamic RAM usage	525
6.3.2.7.4	Performance	526
6.3.3	Universal NAND driver	528
6.3.3.1	Supported hardware	528
6.3.3.2	Theory of operation	531
6.3.3.3	Support for custom hardware	531
6.3.3.4	Partial write operations	532
6.3.3.5	High-reliability operation	532
6.3.3.6	Configuring the driver	532
6.3.3.6.1	Compile time configuration	532
6.3.3.6.2	Runtime configuration	536
6.3.3.7	Additional driver functions	561
6.3.3.7.1	FS_NAND_UNI_Clean()	562
6.3.3.7.2	FS_NAND_UNI_EraseBlock()	563
6.3.3.7.3	FS_NAND_UNI_EraseFlash()	564
6.3.3.7.4	FS_NAND_UNI_GetBlockInfo()	565
6.3.3.7.5	FS_NAND_UNI_GetBlockInfoEx()	566
6.3.3.7.6	FS_NAND_UNI_GetDiskInfo()	567
6.3.3.7.7	FS_NAND_UNI_GetStatCounters()	568
6.3.3.7.8	FS_NAND_UNI_IsBlockBad()	569
6.3.3.7.9	FS_NAND_UNI_Mount()	570
6.3.3.7.10	FS_NAND_UNI_ReadLogSectorPartial()	571
6.3.3.7.11	FS_NAND_UNI_ReadPageRaw()	572
6.3.3.7.12	FS_NAND_UNI_ReadPhySector()	573
6.3.3.7.13	FS_NAND_UNI_ResetStatCounters()	574
6.3.3.7.14	FS_NAND_UNI_TestBlock()	575
6.3.3.7.15	FS_NAND_UNI_WritePage()	577
6.3.3.7.16	FS_NAND_UNI_WritePageRaw()	578
6.3.3.7.17	Bad block marking types	579
6.3.3.7.18	Block info flags	580
6.3.3.7.19	ECC correction status	581
6.3.3.7.20	FS_NAND_MOUNT_INFO	582
6.3.3.7.21	FS_NAND_STAT_COUNTERS	583
6.3.3.7.22	FS_NAND_TEST_INFO	585
6.3.3.7.23	NAND block types	586
6.3.3.7.24	NAND test return values	587
6.3.3.8	Performance and resource usage	588
6.3.3.8.1	ROM usage	588
6.3.3.8.2	Static RAM usage	588
6.3.3.8.3	Dynamic RAM usage	588
6.3.3.8.4	Performance	588
6.3.4	NAND physical layer	590
6.3.4.1	General information	590
6.3.4.2	512x8 physical layer	591
6.3.4.2.1	Runtime configuration	591
6.3.4.3	2048x8 physical layer	593
6.3.4.3.1	Compile time configuration	593
6.3.4.3.2	Runtime configuration	593
6.3.4.4	Two plane 2048x8 physical layer	598
6.3.4.5	Small 2048x8 physical layer	599
6.3.4.6	2048x16 physical layer	600
6.3.4.6.1	Runtime configuration	600
6.3.4.7	4096x8 physical layer	602
6.3.4.7.1	Runtime configuration	602
6.3.4.8	DataFlash physical layer	604
6.3.4.8.1	Compile time configuration	604
6.3.4.8.2	Runtime configuration	604
6.3.4.9	ONFI physical layer	609

6.3.4.9.1	Compile time configuration	609
6.3.4.9.2	Runtime configuration	609
6.3.4.10	Read-only ONFI physical layer	612
6.3.4.11	Small ONFI physical layer	613
6.3.4.12	Quad-SPI physical layer	614
6.3.4.12.1	Compile time configuration	614
6.3.4.12.2	Runtime configuration	615
6.3.4.13	SPI physical layer	622
6.3.4.13.1	Compile time configuration	622
6.3.4.13.2	Runtime configuration	623
6.3.4.14	8/16-bit data bus physical layer	628
6.3.4.14.1	Compile time configuration	628
6.3.4.14.2	Runtime configuration	628
6.3.4.15	8-bit data bus physical layer	631
6.3.4.15.1	Compile time configuration	631
6.3.4.15.2	Runtime configuration	631
6.3.4.16	Physical layer API	633
6.3.4.16.1	FS_NAND_PHY_TYPE	634
6.3.4.16.2	FS_NAND_PHY_TYPE_ERASE_BLOCK	635
6.3.4.16.3	FS_NAND_PHY_TYPE_INIT_GET_DEVICE_INFO	636
6.3.4.16.4	FS_NAND_PHY_TYPE_IS_WP	637
6.3.4.16.5	FS_NAND_PHY_TYPE_READ	638
6.3.4.16.6	FS_NAND_PHY_TYPE_READ_EX	639
6.3.4.16.7	FS_NAND_PHY_TYPE_WRITE	640
6.3.4.16.8	FS_NAND_PHY_TYPE_WRITE_EX	641
6.3.4.16.9	FS_NAND_PHY_TYPE_ENABLE_ECC	642
6.3.4.16.10	FS_NAND_PHY_TYPE_DISABLE_ECC	643
6.3.4.16.11	FS_NAND_PHY_TYPE_CONFIGURE_ECC	644
6.3.4.16.12	FS_NAND_PHY_TYPE_COPY_PAGE	645
6.3.4.16.13	FS_NAND_PHY_TYPE_GET_ECC_RESULT	646
6.3.4.16.14	FS_NAND_PHY_TYPE_DEINIT	647
6.3.4.16.15	FS_NAND_PHY_TYPE_SET_RAW_MODE	648
6.3.4.16.16	FS_NAND_DEVICE_INFO	649
6.3.4.16.17	FS_NAND_ECC_INFO	650
6.3.4.16.18	FS_NAND_ECC_RESULT	651
6.3.4.17	Additional physical layer functions	651
6.3.4.17.1	FS_NAND_PHY_ReadDeviceId()	652
6.3.4.17.2	FS_NAND_PHY_ReadONFIPara()	654
6.3.4.17.3	FS_NAND_PHY_SetHWType()	656
6.3.4.18	Resource usage	656
6.3.4.18.1	ROM usage	656
6.3.4.18.2	Static RAM usage	656
6.3.4.18.3	Dynamic RAM usage	657
6.3.5	NAND hardware layer	658
6.3.5.1	General information	658
6.3.5.2	Hardware layer types	658
6.3.5.3	Hardware layer API - FS_NAND_HW_TYPE	659
6.3.5.3.1	FS_NAND_HW_TYPE	660
6.3.5.3.2	FS_NAND_HW_TYPE_INIT_X8	661
6.3.5.3.3	FS_NAND_HW_TYPE_INIT_X16	662
6.3.5.3.4	FS_NAND_HW_TYPE_DISABLE_CE	663
6.3.5.3.5	FS_NAND_HW_TYPE_ENABLE_CE	664
6.3.5.3.6	FS_NAND_HW_TYPE_SET_ADDR_MODE	665
6.3.5.3.7	FS_NAND_HW_TYPE_SET_CMD_MODE	666
6.3.5.3.8	FS_NAND_HW_TYPE_SET_DATA_MODE	667
6.3.5.3.9	FS_NAND_HW_TYPE_WAIT_WHILE_BUSY	668
6.3.5.3.10	FS_NAND_HW_TYPE_READ_X8	669
6.3.5.3.11	FS_NAND_HW_TYPE_WRITE_X8	670
6.3.5.3.12	FS_NAND_HW_TYPE_READ_X16	671
6.3.5.3.13	FS_NAND_HW_TYPE_WRITE_X16	672

6.3.5.3.14	Sample implementation	673
6.3.5.4	Hardware layer API - FS_NAND_HW_TYPE_DF	680
6.3.5.4.1	FS_NAND_HW_TYPE_DF	681
6.3.5.4.2	FS_NAND_HW_TYPE_DF_INIT	682
6.3.5.4.3	FS_NAND_HW_TYPE_DF_ENABLE_CS	683
6.3.5.4.4	FS_NAND_HW_TYPE_DF_DISABLE_CS	684
6.3.5.4.5	FS_NAND_HW_TYPE_DF_READ	685
6.3.5.4.6	FS_NAND_HW_TYPE_DF_WRITE	686
6.3.5.4.7	Sample implementation	687
6.3.5.5	Hardware layer API - FS_NAND_HW_TYPE_QSPI	693
6.3.5.5.1	FS_NAND_HW_TYPE_QSPI	694
6.3.5.5.2	FS_NAND_HW_TYPE_QSPI_INIT	695
6.3.5.5.3	FS_NAND_HW_TYPE_QSPI_EXEC_CMD	696
6.3.5.5.4	FS_NAND_HW_TYPE_QSPI_READ_DATA	697
6.3.5.5.5	FS_NAND_HW_TYPE_QSPI_WRITE_DATA	698
6.3.5.5.6	FS_NAND_HW_TYPE_QSPI_POLL	699
6.3.5.5.7	FS_NAND_HW_TYPE_QSPI_DELAY	701
6.3.5.5.8	FS_NAND_HW_TYPE_QSPI_LOCK	702
6.3.5.5.9	FS_NAND_HW_TYPE_QSPI_UNLOCK	703
6.3.5.5.10	SPI bus width decoding	704
6.3.5.5.11	Sample implementation	705
6.3.5.6	Hardware layer API - FS_NAND_HW_TYPE_SPI	718
6.3.5.6.1	FS_NAND_HW_TYPE_SPI	719
6.3.5.6.2	FS_NAND_HW_TYPE_SPI_INIT	720
6.3.5.6.3	FS_NAND_HW_TYPE_SPI_DISABLE_CS	721
6.3.5.6.4	FS_NAND_HW_TYPE_SPI_ENABLE_CS	722
6.3.5.6.5	FS_NAND_HW_TYPE_SPI_DELAY	723
6.3.5.6.6	FS_NAND_HW_TYPE_SPI_READ	724
6.3.5.6.7	FS_NAND_HW_TYPE_SPI_WRITE	725
6.3.5.6.8	FS_NAND_HW_TYPE_SPI_LOCK	726
6.3.5.6.9	FS_NAND_HW_TYPE_SPI_UNLOCK	727
6.3.6	Test hardware	728
6.3.7	FAQs	729
6.4	NOR flash driver	730
6.4.1	General information	730
6.4.1.1	Software structure	730
6.4.1.2	Garbage collection	730
6.4.1.3	Fail-safe operation	730
6.4.1.4	Wear leveling	731
6.4.1.5	Low-level format	731
6.4.1.6	CRC verification	731
6.4.1.7	Bit error correction	732
6.4.1.8	Supported hardware	732
6.4.1.8.1	Using the same NOR flash device for code and data	736
6.4.1.9	Interfacing with a NOR flash device	736
6.4.1.10	Common flash interface (CFI)	737
6.4.2	Sector Map NOR driver	738
6.4.2.1	Theory of operation	738
6.4.2.2	Configuring the driver	738
6.4.2.2.1	Compile time configuration	738
6.4.2.2.2	Runtime configuration	741
6.4.2.2.3	Additional sample configurations	756
6.4.2.3	Additional driver functions	759
6.4.2.3.1	FS_NOR_EraseDevice()	760
6.4.2.3.2	FS_NOR_ErasePhySector()	761
6.4.2.3.3	FS_NOR_FormatLow()	762
6.4.2.3.4	FS_NOR_GetDiskInfo()	763
6.4.2.3.5	FS_NOR_GetSectorInfo()	764
6.4.2.3.6	FS_NOR_GetStatCounters()	765
6.4.2.3.7	FS_NOR_IsLLFormatted()	766

6.4.2.3.8	FS_NOR_LogSector2PhySectorAddr()	767
6.4.2.3.9	FS_NOR_ReadOff()	768
6.4.2.3.10	FS_NOR_ResetStatCounters()	769
6.4.2.3.11	FS_NOR_WriteOff()	770
6.4.2.3.12	FS_NOR_DISK_INFO	771
6.4.2.3.13	FS_NOR_SECTOR_INFO	772
6.4.2.4	Performance and resource usage	773
6.4.2.4.1	ROM usage	773
6.4.2.4.2	Static RAM usage	773
6.4.2.4.3	Dynamic RAM usage	773
6.4.2.4.4	Performance	773
6.4.2.5	FAQs	775
6.4.3	Block Map NOR driver	776
6.4.3.1	Theory of operation	776
6.4.3.2	Configuring the driver	776
6.4.3.2.1	Compile time configuration	776
6.4.3.2.2	Runtime configuration	782
6.4.3.3	Additional driver functions	816
6.4.3.3.1	FS_NOR_BM_EraseDevice()	817
6.4.3.3.2	FS_NOR_BM_ErasePhySector()	818
6.4.3.3.3	FS_NOR_BM_FormatLow()	819
6.4.3.3.4	FS_NOR_BM_GetDiskInfo()	820
6.4.3.3.5	FS_NOR_BM_GetSectorInfo()	822
6.4.3.3.6	FS_NOR_BM_GetStatCounters()	824
6.4.3.3.7	FS_NOR_BM_IsCRCEnabled()	826
6.4.3.3.8	FS_NOR_BM_IsECCEnabled()	827
6.4.3.3.9	FS_NOR_BM_IsLLFormatted()	828
6.4.3.3.10	FS_NOR_BM_Mount()	829
6.4.3.3.11	FS_NOR_BM_ReadOff()	830
6.4.3.3.12	FS_NOR_BM_ResetStatCounters()	831
6.4.3.3.13	FS_NOR_BM_SuspendWearLeveling()	832
6.4.3.3.14	FS_NOR_BM_WriteOff()	833
6.4.3.3.15	FS_NOR_BM_DISK_INFO	834
6.4.3.3.16	FS_NOR_BM_MOUNT_INFO	835
6.4.3.3.17	FS_NOR_BM_SECTOR_INFO	836
6.4.3.4	Performance and resource usage	839
6.4.3.4.1	ROM usage	839
6.4.3.4.2	Static RAM usage	839
6.4.3.4.3	Dynamic RAM usage	839
6.4.3.4.4	Performance	839
6.4.4	NOR physical layer	840
6.4.4.1	General information	840
6.4.4.2	CFI 1x16 physical layer	841
6.4.4.2.1	Compile time configuration	841
6.4.4.2.2	Runtime configuration	842
6.4.4.3	CFI 2x16 physical layer	848
6.4.4.4	DSPI physical layer	849
6.4.4.4.1	Compile time configuration	849
6.4.4.4.2	Runtime configuration	849
6.4.4.5	SFDP physical layer	851
6.4.4.5.1	Compile time configuration	851
6.4.4.5.2	Runtime configuration	852
6.4.4.6	SPIFI physical layer	862
6.4.4.6.1	Compile configuration	862
6.4.4.6.2	Runtime configuration	863
6.4.4.6.3	Additional functions	872
6.4.4.7	ST M25 physical layer	874
6.4.4.7.1	Compile time configuration	874
6.4.4.7.2	Runtime configuration	875
6.4.4.7.3	Additional functions	883

6.4.4.8	Physical layer API	885
6.4.4.8.1	FS_NOR_PHY_TYPE	886
6.4.4.8.2	FS_NOR_PHY_TYPE_WRITE_OFF	887
6.4.4.8.3	FS_NOR_PHY_TYPE_READ_OFF	888
6.4.4.8.4	FS_NOR_PHY_TYPE_ERASE_SECTOR	889
6.4.4.8.5	FS_NOR_PHY_TYPE_GET_SECTOR_INFO	890
6.4.4.8.6	FS_NOR_PHY_TYPE_GET_NUM_SECTORS	891
6.4.4.8.7	FS_NOR_PHY_TYPE_CONFIGURE	892
6.4.4.8.8	FS_NOR_PHY_TYPE_ON_SELECT_PHY	893
6.4.4.8.9	FS_NOR_PHY_TYPE_DE_INIT	894
6.4.4.8.10	FS_NOR_PHY_TYPE_IS_SECTOR_BLANK	895
6.4.4.8.11	FS_NOR_PHY_TYPE_INIT	896
6.4.4.9	Resource usage	897
6.4.4.9.1	ROM usage	897
6.4.4.9.2	Static RAM usage	897
6.4.4.9.3	Dynamic RAM usage	897
6.4.5	NOR hardware layer	898
6.4.5.1	General information	898
6.4.5.2	Hardware layer API - FS_NOR_HW_TYPE_SPI	899
6.4.5.2.1	FS_NOR_HW_TYPE_SPI	900
6.4.5.2.2	FS_NOR_HW_TYPE_SPI_INIT	901
6.4.5.2.3	FS_NOR_HW_TYPE_SPI_ENABLE_CS	902
6.4.5.2.4	FS_NOR_HW_TYPE_SPI_DISABLE_CS	903
6.4.5.2.5	FS_NOR_HW_TYPE_SPI_READ	904
6.4.5.2.6	FS_NOR_HW_TYPE_SPI_WRITE	905
6.4.5.2.7	FS_NOR_HW_TYPE_SPI_READ_X2	906
6.4.5.2.8	FS_NOR_HW_TYPE_SPI_WRITE_X2	907
6.4.5.2.9	FS_NOR_HW_TYPE_SPI_READ_X4	908
6.4.5.2.10	FS_NOR_HW_TYPE_SPI_WRITE_X4	909
6.4.5.2.11	FS_NOR_HW_TYPE_SPI_DELAY	910
6.4.5.2.12	FS_NOR_HW_TYPE_SPI_LOCK	911
6.4.5.2.13	FS_NOR_HW_TYPE_SPI_UNLOCK	912
6.4.5.2.14	FS_NOR_HW_TYPE_SPI_READ_EX	913
6.4.5.2.15	FS_NOR_HW_TYPE_SPI_WRITE_EX	914
6.4.5.2.16	Sample implementation	915
6.4.5.3	Hardware layer API - FS_NOR_HW_TYPE_SPIFI	928
6.4.5.3.1	FS_NOR_HW_TYPE_SPIFI	929
6.4.5.3.2	FS_NOR_HW_TYPE_SPIFI_INIT	930
6.4.5.3.3	FS_NOR_HW_TYPE_SPIFI_UNMAP	931
6.4.5.3.4	FS_NOR_HW_TYPE_SPIFI_MAP	932
6.4.5.3.5	FS_NOR_HW_TYPE_SPIFI_CONTROL	933
6.4.5.3.6	FS_NOR_HW_TYPE_SPIFI_READ	934
6.4.5.3.7	FS_NOR_HW_TYPE_SPIFI_WRITE	936
6.4.5.3.8	FS_NOR_HW_TYPE_SPIFI_POLL	937
6.4.5.3.9	FS_NOR_HW_TYPE_SPIFI_DELAY	938
6.4.5.3.10	FS_NOR_HW_TYPE_SPIFI_LOCK	939
6.4.5.3.11	FS_NOR_HW_TYPE_SPIFI_UNLOCK	940
6.4.5.3.12	FS_NOR_HW_TYPE_SPIFI_MAP_EX	941
6.4.5.3.13	FS_NOR_HW_TYPE_SPIFI_CONTROL_EX	942
6.4.5.3.14	FS_NOR_HW_TYPE_SPIFI_READ_EX	943
6.4.5.3.15	FS_NOR_HW_TYPE_SPIFI_WRITE_EX	945
6.4.5.3.16	FS_NOR_HW_TYPE_SPIFI_POLL_EX	946
6.4.5.3.17	NOR HW layer flags	947
6.4.5.3.18	Sample implementation	948
6.5	MMC/SD card driver	962
6.5.1	General information	962
6.5.1.1	Fail-safe operation	962
6.5.1.2	Wear leveling	962
6.5.1.3	CRC verification	962
6.5.1.4	Power control	963

6.5.1.5	Supported hardware	963
6.5.1.6	Pin description - MMC/SD card in card mode	964
6.5.1.7	Pin description - MMC/SD card in SPI mode	966
6.5.1.8	Interfacing with an MMC/SD card	967
6.5.2	SPI MMC/SD driver	969
6.5.2.1	Theory of operation	969
6.5.2.2	Configuring the driver	969
6.5.2.2.1	Runtime configuration	969
6.5.2.3	Additional driver functions	972
6.5.2.3.1	FS_MMC_GetCardId()	973
6.5.2.3.2	FS_MMC_GetCardInfo()	975
6.5.2.3.3	FS_MMC_GetStatCounters()	977
6.5.2.3.4	FS_MMC_ResetStatCounters()	978
6.5.2.4	Performance and resource usage	979
6.5.2.4.1	ROM usage	979
6.5.2.4.2	Static RAM usage	979
6.5.2.4.3	Dynamic RAM usage	979
6.5.2.4.4	Performance	979
6.5.3	Card Mode MMC/SD driver	980
6.5.3.1	Configuring the driver	980
6.5.3.1.1	Compile time configuration	980
6.5.3.1.2	Runtime configuration	982
6.5.3.2	Additional driver functions	1005
6.5.3.2.1	FS_MMC_CM_EnterPowerSaveMode()	1007
6.5.3.2.2	FS_MMC_CM_Erase()	1008
6.5.3.2.3	FS_MMC_CM_GetCardId()	1009
6.5.3.2.4	FS_MMC_CM_GetCardInfo()	1011
6.5.3.2.5	FS_MMC_CM_GetStatCounters()	1013
6.5.3.2.6	FS_MMC_CM_ReadCSD()	1014
6.5.3.2.7	FS_MMC_CM_ReadExtCSD()	1015
6.5.3.2.8	FS_MMC_CM_ReadGeneral()	1016
6.5.3.2.9	FS_MMC_CM_ReadSectors()	1017
6.5.3.2.10	FS_MMC_CM_ResetStatCounters()	1018
6.5.3.2.11	FS_MMC_CM_UnlockCardForced()	1019
6.5.3.2.12	FS_MMC_CM_WriteExtCSD()	1020
6.5.3.2.13	FS_MMC_CM_WriteGeneral()	1021
6.5.3.2.14	FS_MMC_CM_WriteSectors()	1022
6.5.3.2.15	FS_MMC_CARD_ID	1023
6.5.3.2.16	FS_MMC_CARD_INFO	1024
6.5.3.2.17	FS_MMC_STAT_COUNTERS	1025
6.5.3.2.18	Data transfer types	1026
6.5.3.2.19	Storage card types	1027
6.5.3.3	Performance and resource usage	1028
6.5.3.3.1	ROM usage	1028
6.5.3.3.2	Static RAM usage	1028
6.5.3.3.3	Dynamic RAM usage	1028
6.5.3.3.4	Performance	1028
6.5.4	MMC/SD hardware layer	1029
6.5.4.1	Hardware layer types	1029
6.5.4.2	Hardware layer API - FS_MMC_HW_TYPE_SPI	1030
6.5.4.2.1	FS_MMC_HW_TYPE_SPI	1031
6.5.4.2.2	FS_MMC_HW_TYPE_SPI_ENABLE_CS	1032
6.5.4.2.3	FS_MMC_HW_TYPE_SPI_DISABLE_CS	1033
6.5.4.2.4	FS_MMC_HW_TYPE_SPI_IS_PRESENT	1034
6.5.4.2.5	FS_MMC_HW_TYPE_SPI_IS_WRITE_PROTECTED	1035
6.5.4.2.6	FS_MMC_HW_TYPE_SPI_SET_MAX_SPEED	1036
6.5.4.2.7	FS_MMC_HW_TYPE_SPI_SET_VOLTAGE	1037
6.5.4.2.8	FS_MMC_HW_TYPE_SPI_READ	1038
6.5.4.2.9	FS_MMC_HW_TYPE_SPI_WRITE	1039
6.5.4.2.10	FS_MMC_HW_TYPE_SPI_READ_EX	1040

- 6.5.4.2.11 FS_MMC_HW_TYPE_SPI_WRITE_EX 1041
- 6.5.4.2.12 FS_MMC_HW_TYPE_SPI_LOCK 1042
- 6.5.4.2.13 FS_MMC_HW_TYPE_SPI_UNLOCK 1043
- 6.5.4.2.14 Sample implementation 1044
- 6.5.4.3 Hardware layer API - FS_MMC_HW_TYPE_CM 1058
 - 6.5.4.3.1 FS_MMC_HW_TYPE_CM 1059
 - 6.5.4.3.2 FS_MMC_HW_TYPE_CM_INIT1061
 - 6.5.4.3.3 FS_MMC_HW_TYPE_CM_DELAY1062
 - 6.5.4.3.4 FS_MMC_HW_TYPE_CM_IS_PRESENT 1063
 - 6.5.4.3.5 FS_MMC_HW_TYPE_CM_IS_WRITE_PROTECTED 1064
 - 6.5.4.3.6 FS_MMC_HW_TYPE_CM_SET_MAX_SPEED1065
 - 6.5.4.3.7 FS_MMC_HW_TYPE_CM_SET_RESPONSE_TIMEOUT 1066
 - 6.5.4.3.8 FS_MMC_HW_TYPE_CM_SET_READ_DATA_TIMEOUT 1067
 - 6.5.4.3.9 FS_MMC_HW_TYPE_CM_SEND_CMD1068
 - 6.5.4.3.10 FS_MMC_HW_TYPE_CM_GET_RESPONSE1069
 - 6.5.4.3.11 FS_MMC_HW_TYPE_CM_READ_DATA 1071
 - 6.5.4.3.12 FS_MMC_HW_TYPE_CM_WRITE_DATA1072
 - 6.5.4.3.13 FS_MMC_HW_TYPE_CM_SET_DATA_POINTER 1073
 - 6.5.4.3.14 FS_MMC_HW_TYPE_CM_SET_BLOCK_LEN 1074
 - 6.5.4.3.15 FS_MMC_HW_TYPE_CM_SET_NUM_BLOCKS 1075
 - 6.5.4.3.16 FS_MMC_HW_TYPE_CM_GET_MAX_READ_BURST 1076
 - 6.5.4.3.17 FS_MMC_HW_TYPE_CM_GET_MAX_WRITE_BURST 1077
 - 6.5.4.3.18 FS_MMC_HW_TYPE_CM_GET_MAX_REPEAT_WRITE_BURST
..... 1078
 - 6.5.4.3.19 FS_MMC_HW_TYPE_CM_GET_MAX_FILL_WRITE_BURST
..... 1079
 - 6.5.4.3.20 FS_MMC_HW_TYPE_CM_SET_VOLTAGE 1080
 - 6.5.4.3.21 FS_MMC_HW_TYPE_CM_GET_VOLTAGE 1081
 - 6.5.4.3.22 FS_MMC_HW_TYPE_CM_SET_MAX_CLOCK1082
 - 6.5.4.3.23 FS_MMC_HW_TYPE_CM_ENABLE_TUNING 1083
 - 6.5.4.3.24 FS_MMC_HW_TYPE_CM_DISABLE_TUNING 1084
 - 6.5.4.3.25 FS_MMC_HW_TYPE_CM_START_TUNING 1085
 - 6.5.4.3.26 FS_MMC_HW_TYPE_CM_GET_MAX_TUNINGS 1086
 - 6.5.4.3.27 Card mode command flags 1087
 - 6.5.4.3.28 Card mode clock flags 1088
 - 6.5.4.3.29 Card mode error codes 1089
 - 6.5.4.3.30 Card mode response formats 1090
 - 6.5.4.3.31 Sample implementation 1091
- 6.5.5 Troubleshooting 1114
 - 6.5.5.1 SPI mode troubleshooting guide 1114
- 6.5.6 Test hardware 1117
- 6.6 CompactFlash card and IDE driver 1119
 - 6.6.1 General information 1119
 - 6.6.1.1 Fail-safe operation 1119
 - 6.6.1.2 Wear-leveling 1119
 - 6.6.1.3 Supported hardware1119
 - 6.6.1.3.1 Pin description - True IDE mode 1119
 - 6.6.1.3.2 Pin description - Memory card mode 1120
 - 6.6.1.4 Theory of operation 1122
 - 6.6.1.4.1 CompactFlash card1122
 - 6.6.1.5 IDE (ATA) Drives 1122
 - 6.6.1.6 Configuring the driver 1122
 - 6.6.1.7 Runtime configuration 1122
 - 6.6.1.7.1 FS_IDE_Configure() 1124
 - 6.6.1.7.2 FS_IDE_SetHWType() 1125
 - 6.6.2 CF/IDE hardware layer 1125
 - 6.6.2.1 Hardware layer API - FS_IDE_HW_TYPE 1126
 - 6.6.2.1.1 FS_IDE_HW_TYPE 1127
 - 6.6.2.1.2 FS_IDE_HW_TYPE_RESET 1128
 - 6.6.2.1.3 FS_IDE_HW_TYPE_IS_PRESENT1129

6.6.2.1.4	FS_IDE_HW_TYPE_DELAY_400NS	1130
6.6.2.1.5	FS_IDE_HW_TYPE_READ_REG	1131
6.6.2.1.6	FS_IDE_HW_TYPE_WRITE_REG	1132
6.6.2.1.7	FS_IDE_HW_TYPE_READ_DATA	1133
6.6.2.1.8	FS_IDE_HW_TYPE_WRITE_DATA	1134
6.6.3	Performance and resource usage	1135
6.6.3.1	ROM usage	1135
6.6.3.2	Static RAM usage	1135
6.6.3.2.1	Dynamic RAM usage	1135
6.6.3.3	Performance	1135
6.7	Windows Drive driver	1136
6.7.1	Supported hardware	1136
6.7.2	Theory of operation	1136
6.7.3	Fail-safe operation	1136
6.7.4	Wear-leveling	1136
6.7.5	Configuring the Windows Drive driver	1136
6.7.5.1	Compile time configuration	1136
6.7.5.1.1	FS_WINDRIVE_SECTOR_SIZE	1137
6.7.5.1.2	FS_WINDRIVE_NUM_UNITS	1137
6.7.5.2	Runtime configuration	1137
6.7.5.2.1	FS_WINDRIVE_Configure()	1138
6.7.5.2.2	FS_WINDRIVE_ConfigureEx()	1139
6.7.5.2.3	FS_WINDRIVE_SetGeometry()	1140
6.8	File Disk driver	1142
6.8.1	Supported hardware	1142
6.8.2	Theory of operation	1142
6.8.3	Fail-safe operation	1142
6.8.4	Wear-leveling	1142
6.8.5	Configuring the File Disk driver	1142
6.8.5.1	Compile time configuration	1142
6.8.5.1.1	FS_FILEDISK_NUM_UNITS	1142
6.8.5.1.2	FS_FILEDISK_SUPPORT_TRIM	1142
6.8.5.2	Runtime configuration	1143
6.8.5.2.1	FS_FILEDISK_Configure()	1144
6.8.5.3	Additional driver functions	1145
6.8.5.3.1	FS_FILEDISK_GetDiskInfo()	1146
6.8.5.3.2	FS_FILEDISK_DISK_INFO	1147
7	Logical drivers	1148
7.1	General information	1149
7.2	Disk Partition driver	1150
7.2.1	Master Boot Record	1150
7.2.2	Configuring the driver	1150
7.2.2.1	Runtime configuration	1150
7.2.2.1.1	FS_DISKPART_Configure()	1151
7.2.3	Performance and resource usage	1153
7.2.3.1	ROM usage	1153
7.2.3.2	Static RAM usage	1153
7.2.3.3	Dynamic RAM usage	1153
7.3	Encryption driver	1154
7.3.1	Theory of operation	1154
7.3.2	Configuring the driver	1154
7.3.2.1	Runtime configuration	1154
7.3.2.1.1	FS_CRYPT_Configure()	1155
7.3.3	Performance and resource usage	1157
7.3.3.1	ROM usage	1157
7.3.3.2	Static RAM usage	1157
7.3.3.3	Dynamic RAM usage	1157
7.3.3.4	Performance	1157

7.4	Sector Read-Ahead driver	1158
7.4.1	Configuring the driver	1158
7.4.1.1	Runtime configuration	1158
7.4.1.1.1	FS_READAHEAD_Configure()	1159
7.4.2	Additional driver functions	1159
7.4.2.1	FS_READAHEAD_GetStatCounters()	1161
7.4.2.2	FS_READAHEAD_ResetStatCounters()	1162
7.4.2.3	FS_READAHEAD_STAT_COUNTERS	1163
7.4.3	Performance and resource usage	1164
7.4.3.1	ROM usage	1164
7.4.3.2	Static RAM usage	1164
7.4.3.3	Dynamic RAM usage	1164
7.4.3.4	Performance	1164
7.5	Sector Size Adapter driver	1165
7.5.1	Configuring the driver	1165
7.5.1.1	FS_SECSIZE_Configure()	1166
7.5.2	Performance and resource usage	1167
7.5.2.1	ROM usage	1167
7.5.2.2	Static RAM usage	1167
7.5.2.3	Dynamic RAM usage	1167
7.6	Sector Write Buffer driver	1168
7.6.1	Configuring the driver	1168
7.6.1.1	Runtime configuration	1168
7.6.1.1.1	FS_WRBUF_Configure()	1169
7.6.1.1.2	Write buffer size	1170
7.6.2	Performance and resource usage	1171
7.6.2.1	ROM usage	1171
7.6.2.2	Static RAM usage	1171
7.6.2.3	Dynamic RAM usage	1171
7.7	RAID1 driver	1172
7.7.1	Theory of operation	1172
7.7.2	NAND flash error recovery	1172
7.7.3	Sector data synchronization	1172
7.7.4	Configuring the driver	1172
7.7.4.1	Runtime configuration	1172
7.7.4.1.1	FS_RAID1_Configure()	1174
7.7.4.1.2	FS_RAID1_SetSectorRanges()	1176
7.7.4.1.3	FS_RAID1_SetSyncBuffer()	1177
7.7.4.1.4	FS_RAID1_SetSyncSource()	1179
7.7.5	Performance and resource usage	1181
7.7.5.1	ROM usage	1181
7.7.5.2	Static RAM usage	1181
7.7.5.3	Runtime RAM usage	1181
7.8	RAID5 driver	1182
7.8.1	Theory of operation	1182
7.8.2	NAND flash error recovery	1182
7.8.3	Configuring the driver	1182
7.8.3.1	Runtime configuration	1182
7.8.3.1.1	FS_RAID5_AddDevice()	1183
7.8.3.1.2	FS_RAID5_SetNumSectors()	1185
7.8.3.1.3	FS_RAID5_GetOperatingMode()	1186
7.8.3.1.4	RAID operating modes	1187
7.8.4	Performance and resource usage	1188
7.8.4.1	ROM usage	1188
7.8.4.2	Static RAM usage	1188
7.8.4.3	Dynamic RAM usage	1188
7.9	Logical Volume driver	1189
7.9.1	Configuring the driver	1189
7.9.1.1	Compile time configuration	1189
7.9.1.1.1	FS_LOGVOL_NUM_UNITS	1189

7.9.1.1.2	FS_LOGVOL_SUPPORT_CLEAN	1189
7.9.1.1.3	FS_LOGVOL_SUPPORT_DRIVER_MODE	1190
7.9.1.1.4	FS_LOGVOL_SUPPORT_TRIM	1190
7.9.1.2	Runtime configuration	1190
7.9.1.2.1	FS_LOGVOL_AddDeviceEx()	1191
7.9.2	Performance and resource usage	1194
7.9.2.1	ROM usage	1194
7.9.2.2	Static RAM usage	1194
7.9.2.3	Dynamic RAM usage	1194
8	Custom drivers	1195
8.1	General information	1196
8.2	Driver layer API	1197
8.2.1	FS_DEVICE_TYPE	1198
8.2.2	FS_DEVICE_TYPE_GET_NAME	1199
8.2.3	FS_DEVICE_TYPE_ADD_DEVICE	1200
8.2.4	FS_DEVICE_TYPE_READ	1201
8.2.5	FS_DEVICE_TYPE_WRITE	1202
8.2.6	FS_DEVICE_TYPE_IOCTL	1203
8.2.7	FS_DEVICE_TYPE_INIT_MEDIUM	1204
8.2.8	FS_DEVICE_TYPE_GET_STATUS	1205
8.2.9	FS_DEVICE_TYPE_GET_NUM_UNITS	1206
8.2.10	FS_ON_READ_ERROR_CALLBACK	1207
8.2.11	FS_READ_ERROR_DATA	1208
8.2.12	I/O command codes	1209
8.3	Template implementation	1212
9	Configuration of emFile	1218
9.1	General information	1219
9.2	Compile time configuration	1220
9.2.1	General file system configuration	1220
9.2.1.1	FS_BUFFER_SIZE_FILE_COPY	1222
9.2.1.2	FS_BUFFER_SIZE_FILE_PRINT	1222
9.2.1.3	FS_BUFFER_SIZE_FILE_WIPE	1222
9.2.1.4	FS_BUFFER_SIZE_TRUNCATE	1222
9.2.1.5	FS_BUFFER_SIZE_VERIFY	1222
9.2.1.6	FS_DIRECTORY_DELIMITER	1222
9.2.1.7	FS_DRIVER_ALIGNMENT	1222
9.2.1.8	FS_FILL_PATTERN_UNUSED_DATA	1222
9.2.1.9	FS_MAX_LEN_FULL_FILE_NAME	1223
9.2.1.10	FS_MAX_LEN_VOLUME_ALIAS	1223
9.2.1.11	FS_MAX_PATH	1223
9.2.1.12	FS_MULTI_HANDLE_SAFE	1223
9.2.1.13	FS_NUM_DIR_HANDLES	1223
9.2.1.14	FS_NUM_VOLUMES	1223
9.2.1.15	FS_OPTIMIZATION_TYPE	1223
9.2.1.15.1	Optimization types	1226
9.2.1.16	FS_OPTIMIZE	1226
9.2.1.17	FS_SUPPORT_BUSY_LED	1226
9.2.1.18	FS_SUPPORT_CACHE	1226
9.2.1.19	FS_SUPPORT_CHECK_MEMORY	1226
9.2.1.20	FS_SUPPORT_DEINIT	1226
9.2.1.21	FS_SUPPORT_EFS	1227
9.2.1.22	FS_SUPPORT_EXT_ASCII	1227
9.2.1.23	FS_SUPPORT_EXT_MEM_MANAGER	1227
9.2.1.24	FS_SUPPORT_FAT	1227
9.2.1.25	FS_SUPPORT_FILE_BUFFER	1227
9.2.1.26	FS_SUPPORT_FILE_NAME_ENCODING	1227
9.2.1.27	FS_SUPPORT_FREE_SECTOR	1227

9.2.1.28	FS_SUPPORT_GPT	1227
9.2.1.29	FS_SUPPORT_MBCS	1228
9.2.1.30	FS_SUPPORT_POSIX	1228
9.2.1.31	FS_SUPPORT_SECTOR_BUFFER_BURST	1228
9.2.1.32	FS_SUPPORT_SECTOR_BUFFER_CACHE	1228
9.2.1.33	FS_SUPPORT_VOLUME_ALIAS	1228
9.2.1.34	FS_SUPPRESS_EOF_ERROR	1228
9.2.1.35	FS_VERIFY_WRITE	1228
9.2.2	FAT configuration	1228
9.2.2.1	FS_FAT_CHECK_UNUSED_DIR_ENTRIES	1229
9.2.2.2	FS_FAT_LFN_LOWER_CASE_SHORT_NAMES	1229
9.2.2.3	FS_FAT_LFN_BIT_ARRAY_SIZE	1230
9.2.2.4	FS_FAT_LFN_MAX_SHORT_NAME	1230
9.2.2.5	FS_FAT_LFN_UNICODE_CONV_DEFAULT	1230
9.2.2.6	FS_FAT_OPTIMIZE_LINEAR_ACCESS	1230
9.2.2.7	FS_FAT_OPTIMIZE_DELETE	1230
9.2.2.8	FS_FAT_PERMIT_RO_FILE_MOVE	1230
9.2.2.9	FS_FAT_SUPPORT_FAT32	1230
9.2.2.10	FS_FAT_SUPPORT_FREE_CLUSTER_CACHE	1230
9.2.2.11	FS_FAT_UPDATE_DIRTY_FLAG	1231
9.2.2.12	FS_FAT_USE_FSINFO_SECTOR	1231
9.2.2.13	FS_MAINTAIN_FAT_COPY	1231
9.2.2.14	FS_UNICODE_UPPERCASE_EXT	1231
9.2.3	EFS configuration	1231
9.2.3.1	FS_EFS_CASE_SENSITIVE	1232
9.2.3.2	FS_EFS_MAX_DIR_ENTRY_SIZE	1232
9.2.3.3	FS_EFS_NUM_DIRENTRY_BUFFERS	1232
9.2.3.4	FS_EFS_OPTIMIZE_DELETE	1232
9.2.3.5	FS_EFS_OPTIMIZE_LINEAR_ACCESS	1232
9.2.3.6	FS_EFS_SUPPORT_STATUS_SECTOR	1232
9.2.3.7	FS_EFS_SUPPORT_DIRENTRY_BUFFERS	1233
9.2.3.8	FS_EFS_SUPPORT_FREE_CLUSTER_CACHE	1233
9.2.4	Storage layer configuration	1233
9.2.4.1	FS_STORAGE_ENABLE_STAT_COUNTERS	1233
9.2.4.2	FS_STORAGE_SUPPORT_DEVICE_ACTIVITY	1233
9.2.4.3	FS_STORAGE_SUPPORT_MOUNT	1233
9.2.5	Standard C function replacement	1234
9.2.5.1	FS_NO_CLIB	1234
9.2.6	Sample configuration	1235
9.3	Runtime configuration	1236
9.3.1	FS_X_AddDevices()	1237
9.3.2	FS_X_GetTimeDate()	1238
10	OS integration	1239
10.1	General information	1240
10.2	Compile time configuration	1241
10.2.1	FS_OS_LOCKING	1241
10.2.1.1	OS locking	1242
10.3	Runtime configuration	1243
10.3.1	FS_X_OS_Init()	1244
10.3.2	FS_X_OS_DeInit()	1245
10.3.3	FS_X_OS_Delay()	1246
10.3.4	FS_X_OS_Lock()	1247
10.3.5	FS_X_OS_Unlock()	1248
10.3.6	FS_X_OS_Wait()	1249
10.3.7	FS_X_OS_Signal()	1250
10.3.8	FS_X_OS_GetTime()	1251
10.3.9	Sample implementation	1252

11	Debugging	1255
11.1	General information	1256
11.2	Debug messages	1257
11.2.1	Debug output and error functions	1257
11.2.2	FS_X_ErrorOut()	1258
11.2.3	FS_X_Log()	1259
11.2.4	FS_X_Panic()	1260
11.2.5	FS_X_Warn()	1261
11.3	Configuration	1262
11.3.1	Compile time configuration	1262
11.3.1.1	FS_DEBUG_LEVEL	1262
11.3.1.1.1	Debug levels	1263
11.3.1.2	FS_DEBUG_MAX_LEN_MESSAGE	1263
11.3.1.3	FS_DEBUG_STATIC_MESSAGE_BUFFER	1263
11.3.1.4	FS_LOG_MASK_DEFAULT	1263
11.3.1.5	FS_X_PANIC()	1264
11.3.2	Runtime configuration	1264
11.3.2.1	FS_AddErrorFilter()	1265
11.3.2.2	FS_AddLogFilter()	1266
11.3.2.3	FS_AddWarnFilter()	1267
11.3.2.4	FS_GetErrorFilter()	1268
11.3.2.5	FS_GetLogFilter()	1269
11.3.2.6	FS_GetWarnFilter()	1270
11.3.2.7	FS_SetErrorFilter()	1271
11.3.2.8	FS_SetLogFilter()	1272
11.3.2.9	FS_SetWarnFilter()	1273
11.3.2.10	Debug message types	1274
11.4	Troubleshooting	1275
12	Profiling with SystemView	1277
12.1	General information	1278
12.2	Configuring profiling	1279
12.2.1	Compile time configuration	1279
12.2.1.1	FS_SUPPORT_PROFILE	1279
12.2.1.2	FS_SUPPORT_PROFILE_END_CALL	1279
12.2.2	Runtime configuration	1279
12.3	Recording and analyzing profiling information	1281
13	Performance and resource usage	1282
13.1	Resource usage	1283
13.1.1	ROM usage	1283
13.1.1.1	Test procedure	1283
13.1.1.2	Test results	1286
13.1.2	Static RAM usage	1286
13.1.3	Dynamic RAM usage	1287
13.2	Performance	1289
13.2.1	Test procedure	1289
13.2.2	How to improve performance	1295
14	Journaling	1297
14.1	General information	1298
14.1.1	Driver fail-safety	1298
14.1.2	Features	1298
14.2	Theory of operation	1299
14.3	Write optimization	1300
14.4	How to use the Journaling component	1301
14.4.1	Combining multiple write operations	1301
14.4.2	Preserving the consistency of a file	1301

14.4.3	Journaling and write caching	1302
14.5	Configuration	1304
14.5.1	Compile time configuration	1304
14.5.1.1	FS_SUPPORT_JOURNAL	1304
14.5.1.2	FS_JOURNAL_FILE_NAME	1304
14.5.1.3	FS_MAX_LEN_JOURNAL_FILE_NAME	1304
14.5.1.4	FS_JOURNAL_ENABLE_STATS	1304
14.5.1.5	FS_JOURNAL_SUPPORT_FREE_SECTOR	1305
14.5.1.6	FS_JOURNAL_SUPPORT_FAST_SECTOR_SEARCH	1305
14.5.1.7	FS_JOURNAL_OPTIMIZE_SPACE_USAGE	1305
14.5.2	Runtime configuration	1305
14.6	API functions	1306
14.6.1	FS_JOURNAL_Begin()	1307
14.6.2	FS_JOURNAL_Create()	1309
14.6.3	FS_JOURNAL_CreateEx()	1312
14.6.4	FS_JOURNAL_Disable()	1313
14.6.5	FS_JOURNAL_Enable()	1314
14.6.6	FS_JOURNAL_End()	1315
14.6.7	FS_JOURNAL_GetInfo()	1316
14.6.8	FS_JOURNAL_GetOpenCnt()	1317
14.6.9	FS_JOURNAL_GetStatCounters()	1318
14.6.10	FS_JOURNAL_Invalidate()	1319
14.6.11	FS_JOURNAL_IsEnabled()	1321
14.6.12	FS_JOURNAL_IsPresent()	1322
14.6.13	FS_JOURNAL_ResetStatCounters()	1323
14.6.14	FS_JOURNAL_SetFileName()	1324
14.6.15	FS_JOURNAL_SetOnOverflowExCallback()	1325
14.6.16	FS_JOURNAL_SetOnOverflowCallback()	1326
14.6.17	FS_JOURNAL_INFO	1327
14.6.18	FS_JOURNAL_ON_OVERFLOW_EX_CALLBACK	1328
14.6.19	FS_JOURNAL_ON_OVERFLOW_CALLBACK	1329
14.6.20	FS_JOURNAL_OVERFLOW_INFO	1330
14.6.21	FS_JOURNAL_STAT_COUNTERS	1331
14.7	Performance and resource usage	1332
14.7.1	ROM usage	1332
14.7.2	Static RAM usage	1332
14.7.3	Dynamic RAM usage	1332
14.7.4	Performance	1332
14.8	FAQs	1333
15	Encryption	1334
15.1	General information	1335
15.2	How to use encryption	1336
15.3	Additional information	1337
15.4	Compile time configuration	1338
15.5	API functions	1339
15.5.1	FS_CRYPT_Prepare()	1340
15.5.2	FS_CRYPT_Decrypt()	1341
15.5.3	FS_CRYPT_Encrypt()	1342
15.5.4	FS_SetEncryptionObject()	1343
15.5.5	FS_CRYPT_ALGO_TYPE	1344
15.5.6	FS_CRYPT_ALGO_TYPE_PREPARE	1345
15.5.7	FS_CRYPT_ALGO_TYPE_ENCRYPT	1346
15.5.8	FS_CRYPT_ALGO_TYPE_DECRYPT	1347
15.6	Encryption utility	1348
15.6.1	Using the file encryption utility	1348
15.6.2	Command line options	1348
15.6.2.1	-a	1349
15.6.2.2	-b	1349

15.6.2.3	-d	1350
15.6.2.4	-h	1350
15.6.2.5	-q	1351
15.6.2.6	-v	1351
15.6.3	Command line arguments	1351
15.6.3.1	<Key>	1351
15.6.3.2	<SrcFile>	1351
15.6.3.3	<DestFile>	1352
15.7	Performance and resource usage	1353
15.7.1	ROM usage	1353
15.7.2	Static RAM usage	1353
15.7.3	Dynamic RAM usage	1353
15.7.4	Performance	1353
16	BigFAT	1354
16.1	General information	1355
16.2	Theory of operation	1356
16.3	Configuration	1357
16.3.1	Compile time configuration	1357
16.4	API functions	1358
16.4.1	FS_BIGFAT_CheckDisk()	1359
16.4.2	FS_BIGFAT_Close()	1361
16.4.3	FS_BIGFAT_Copy()	1362
16.4.4	FS_BIGFAT_FindClose()	1363
16.4.5	FS_BIGFAT_FindFirst()	1364
16.4.6	FS_BIGFAT_FindNext()	1366
16.4.7	FS_BIGFAT_GetInfo()	1367
16.4.8	FS_BIGFAT_GetPos()	1368
16.4.9	FS_BIGFAT_GetSize()	1369
16.4.10	FS_BIGFAT_GetTime()	1370
16.4.11	FS_BIGFAT_ModifyAttr()	1371
16.4.12	FS_BIGFAT_Move()	1372
16.4.13	FS_BIGFAT_Open()	1373
16.4.14	FS_BIGFAT_Read()	1376
16.4.15	FS_BIGFAT_Remove()	1377
16.4.16	FS_BIGFAT_SetPos()	1378
16.4.17	FS_BIGFAT_SetSize()	1379
16.4.18	FS_BIGFAT_SetTime()	1380
16.4.19	FS_BIGFAT_Sync()	1381
16.4.20	FS_BIGFAT_Write()	1382
16.4.21	FS_BIGFAT_INFO	1383
16.4.22	FS_BIGFAT_FIND_DATA	1384
16.4.23	File open flags	1385
16.5	BigFAT converter utility	1386
16.5.1	Using the utility	1386
16.5.2	Command line options	1386
16.5.2.1	-d	1387
16.5.2.2	-h	1387
16.5.2.3	-q	1387
16.5.2.4	-s	1388
16.5.2.5	-v	1388
16.5.3	Command line arguments	1388
16.5.3.1	SrcFile	1388
17	NAND Image Creator	1389
17.1	General information	1390
17.2	Using the NAND Image Creator	1391
17.2.1	Sample script file	1392
17.3	Supported commands	1393

17.3.1	Image related commands	1395
17.3.1.1	createimage	1396
17.3.1.2	setdrvertype	1397
17.3.1.3	setsectorsize	1398
17.3.1.4	addpartition	1399
17.3.1.5	setecclevel	1401
17.3.1.6	setnumworkblocks	1402
17.3.1.7	showimageinfo	1403
17.3.1.8	init	1404
17.3.1.9	exportimage	1405
17.3.2	File and directory related commands	1406
17.3.2.1	cd	1407
17.3.2.2	md	1408
17.3.2.3	rd	1409
17.3.2.4	addfile	1410
17.3.2.5	addfolder	1411
17.3.2.6	type	1412
17.3.2.7	del	1413
17.3.2.8	dir	1414
17.3.2.9	ren	1415
17.3.2.10	move	1416
17.3.2.11	attr	1417
17.3.2.12	copy	1418
17.3.2.13	exportfile	1419
17.3.2.14	exportfolder	1420
17.3.3	Logical sector related commands	1421
17.3.3.1	storesectors	1422
17.3.3.2	dumpsector	1423
17.3.3.3	copysectors	1424
17.3.4	Volume specific commands	1425
17.3.4.1	formatlow	1426
17.3.4.2	format	1427
17.3.4.3	df	1428
17.3.4.4	diskinfo	1429
17.3.4.5	getdevinfo	1430
17.3.4.6	checkdisk	1431
17.3.4.7	creatembr	1432
17.3.4.8	listvolumes	1433
18	NOR Image Creator	1434
18.1	General information	1435
18.2	Using the NOR Image Creator	1436
18.2.1	Sample script file	1437
18.3	Supported commands	1438
18.3.1	Image related commands	1440
18.3.1.1	createimage	1441
18.3.1.2	addsectorblock	1442
18.3.1.3	setsectorsize	1443
18.3.1.4	setlinesize	1444
18.3.1.5	setrewritesupport	1445
18.3.1.6	setbyteorder	1446
18.3.1.7	settimesource	1447
18.3.1.8	setcrcsupport	1448
18.3.1.9	setnumworkblocks	1449
18.3.1.10	showimageinfo	1450
18.3.1.11	init	1451
18.3.1.12	exportimage	1452
18.3.2	File and directory related commands	1453
18.3.2.1	cd	1454

18.3.2.2	md	1455
18.3.2.3	rd	1456
18.3.2.4	addfile	1457
18.3.2.5	addfolder	1458
18.3.2.6	type	1459
18.3.2.7	del	1460
18.3.2.8	dir	1461
18.3.2.9	ren	1462
18.3.2.10	move	1463
18.3.2.11	attrib	1464
18.3.2.12	copy	1465
18.3.2.13	exportfile	1466
18.3.2.14	exportfolder	1467
18.3.3	Volume specific commands	1468
18.3.3.1	formatlow	1469
18.3.3.2	format	1470
18.3.3.3	df	1471
18.3.3.4	diskinfo	1472
18.3.3.5	getdevinfo	1473
18.3.3.6	checkdisk	1474
18.3.3.7	listvol	1475
18.3.3.8	clean	1476
18.3.3.9	createjournal	1477
19	Storage Image Creator	1478
19.1	General information	1479
19.2	Using the Storage Image Creator	1480
19.2.1	Example script file	1481
19.2.2	Example usage	1481
19.3	Supported commands	1482
19.3.1	Image related commands	1483
19.3.1.1	createimage	1484
19.3.1.2	addpartition	1485
19.3.1.3	showimageinfo	1486
19.3.1.4	init	1487
19.3.1.5	exportimage	1488
19.3.2	File and directory related commands	1490
19.3.2.1	cd	1491
19.3.2.2	md	1492
19.3.2.3	rd	1493
19.3.2.4	addfile	1494
19.3.2.5	addfolder	1495
19.3.2.6	type	1496
19.3.2.7	del	1497
19.3.2.8	dir	1498
19.3.2.9	ren	1499
19.3.2.10	move	1500
19.3.2.11	attr	1501
19.3.2.12	copy	1502
19.3.2.13	exportfile	1503
19.3.2.14	exportfolder	1504
19.3.3	Logical sector related commands	1505
19.3.3.1	storesectors	1506
19.3.3.2	dumpsector	1507
19.3.3.3	copysectors	1508
19.3.4	Volume specific commands	1509
19.3.4.1	format	1510
19.3.4.2	df	1511
19.3.4.3	diskinfo	1512

19.3.4.4	getdevinfo	1513
19.3.4.5	checkdisk	1514
19.3.4.6	creatembr	1515
19.3.4.7	listvolumes	1516
19.3.4.8	createjournal	1517
20	Porting emFile 2.x to 3.x	1518
20.1	Differences between version 2.x and 3.x	1519
20.2	API differences	1520
20.3	Configuration differences	1521
21	Porting emFile 3.x to 4.x	1522
21.1	Differences between version 3.x and 4.x	1523
21.2	Hardware layer API differences	1524
21.2.1	NAND device driver differences	1525
21.2.1.1	Porting without hardware layer modification	1525
21.2.1.2	Replacement functions	1526
21.2.2	NOR device driver differences	1528
21.2.2.1	Porting without hardware layer modification	1528
21.2.2.2	Replacement functions	1529
21.2.3	MMC/SD SPI device driver differences	1530
21.2.3.1	Porting without hardware layer modification	1530
21.2.3.2	Replacement functions	1530
21.2.4	MMC/SD card mode device driver differences	1532
21.2.4.1	Porting without hardware layer modification	1532
21.2.4.2	Replacement functions	1532
21.2.5	CompactFlash / IDE device driver differences	1534
21.2.5.1	Porting without hardware layer modification	1534
21.2.5.2	Replacement functions	1534
21.2.6	MMC / SD device driver for ATMEL MCUs	1535
21.2.6.1	Configuration changes	1535
21.2.6.2	Hardware layer changes	1535
22	Porting emFile 4.x to 5.x	1536
22.1	Differences between version 4.x and 5.x	1537
22.2	Function prototype differences	1538
22.3	File naming differences	1543
23	Support	1546
23.1	Contacting SEGGER support	1547
24	FAQs	1548
24.1	Questions and answers	1549
25	Glossary	1550
25.1	List of terms	1551

Chapter 1

Introduction to emFile

This section presents an overview of emFile, its structure, and its capabilities.

1.1 What is emFile

emFile is a file system design for embedded applications which supports NAND, DataFlash, NOR and SPI Flash, SD and MMC Memory Cards, RAM and USB mass storage devices. emFile is a high performance library optimized for high speed, versatility and a minimal memory footprint of both RAM and ROM. It is written in ANSI C and can be used on any CPU.

1.2 Features

The main features of emFile are:

- Two file systems variants: FAT or SEGGER's proprietary Embedded File System (EFS).
- FAT supports MS DOS/MS Windows-compatible FAT12, FAT16 and FAT32.
- EFS natively supports Long File Name (LFN). Add-on for FAT LFN available.
- Multiple device driver support; the same driver can support multiple storage media.
- Multiple media support; device drivers allow concurrent access to different storage media types.
- Cache support via RAM for optimized performance.
- Fail-safe and Task-safe, works with any operating system.
- ANSI C stdio.h-like API. Applications using standard C I/O library can easily be ported to emFile.
- Simple device driver structure, sample code trial versions and extensive API documentation.
- NAND Flash driver for SLC and MLC NAND and DataFlash with ECC and wear leveling.
- NOR Flash driver for NOR, SPI and QSPI Flash with wear leveling.
- Driver for Memory Card devices such as MMC, SD, SDHC, eMMC using bus and SPI mode.
- IDE Driver, Compact Flash, True-IDE and memory mapped mode.
- Journaling, RAID1 and RAID5 options to enhance data integrity.
- FAT Long File Name (LFN).
- Encryption (DES) and Extra Strong Encryption (DES and AES.)
- Profiling via SEGGER SystemView.
- Image creator tools for NOR and NAND.
- NAND flash evaluation board available.
- SQLite integration is available as sample upon request.
- MISRA C:2012 compliant.
- Support for Shift-JIS encoded Japanese file names.
- Support for GBK and Big5 encoded Chinese file names.
- Support for UHC encoded Korean file names.
- Support for files larger than 4 GBytes via BigFAT component.

1.3 Basic concepts

This section describes the software structure of emFile as well as other general concepts such as fail safety and wear leveling.

1.3.1 emFile structure

emFile is organized in different layers as illustrated in the following diagram. A short description of each layer's functionality follows below.

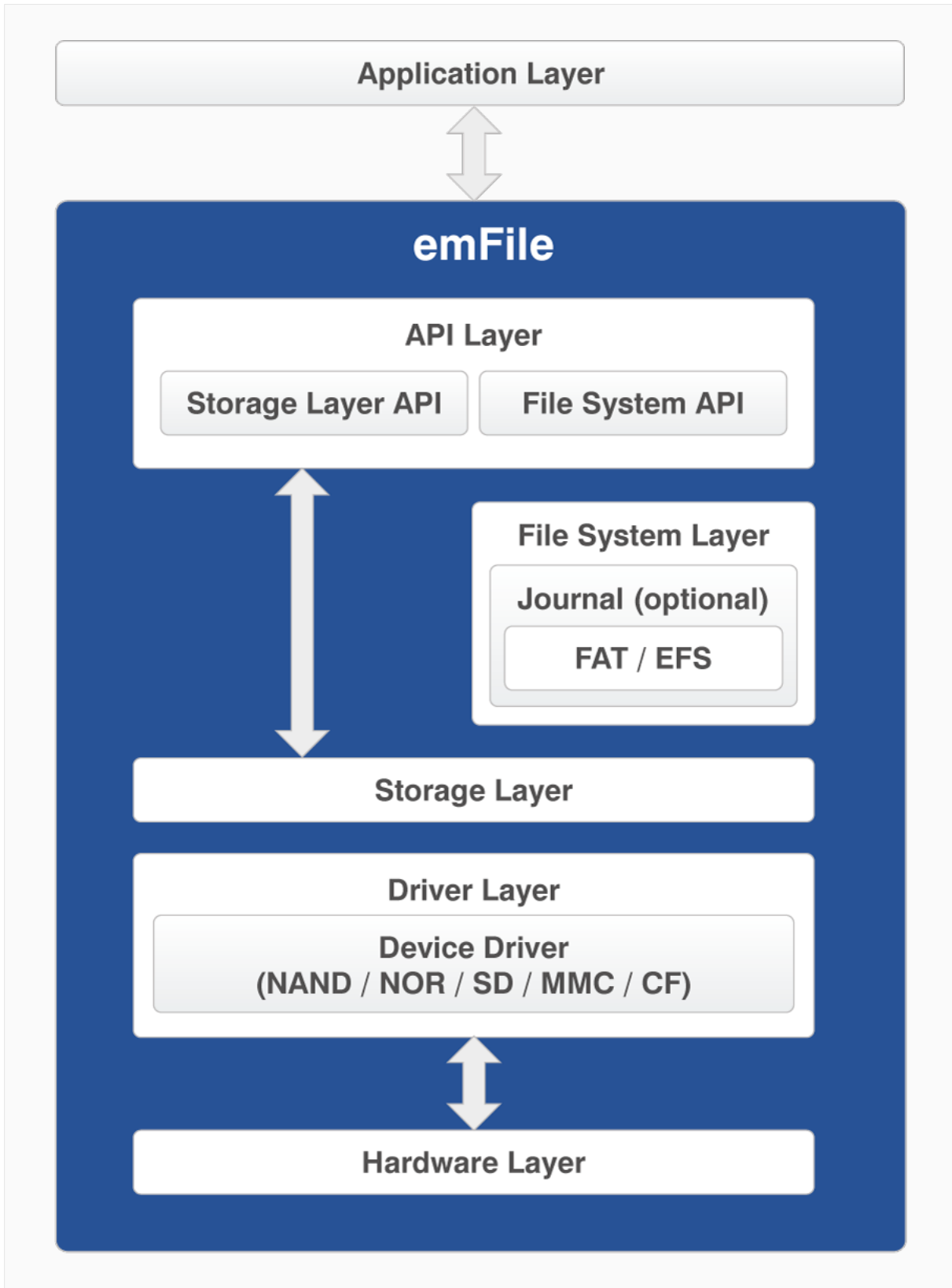

File system structure

1.3.1.1 API layer

The API layer is the interface between emFile and the user application. It is divided in two parts storage API and file system API. The file system API declares file functions in ANSI C standard I/O style, such as `FS_FOpen()`, `FS_FWrite()` etc. The API layer transfers any calls to these functions to the file system layer. Currently the FAT file system or an optional file system, called EFS, are available for emFile. Both file systems can be used simultaneously. The storage API declares the functions which are required to initialize and access a storage medium. The storage API allows sector read and write operations. The API layer transfers these calls to the storage layer. The storage API is optimized for applications which do not require file system functionality like file and directory handling. A typical application which uses the storage API could be a USB mass storage device, where data has to be stored on a medium, but all file system functionality is handled by the host PC.

1.3.1.2 File system layer

The file system layer translates file operations to logical block (sector) operations. After such a translation, the file system calls the logical block layer and specifies the corresponding device driver for a device.

1.3.1.3 Storage layer

The main purpose of the Storage Layer is to synchronize accesses to a device driver. Furthermore, it provides a simple interface for the File System API. The Storage Layer calls a device driver to perform a block operation. It also contains the cache mechanism.

1.3.1.4 Driver layer

Device drivers are low-level routines that are used to access sectors of the device and to check status. It is hardware independent but depends on the storage medium.

1.3.1.5 Hardware layer

These layer contains the low-level routines to access your hardware. These routines simply read and store fixed length sectors. The structure of the device driver is simple in order to allow easy integration of your own hardware.

1.3.2 Choice of file system type: FAT vs. EFS

Within emFile, there is a choice among two different file systems. The first, the FAT file system, is divided into three different sub types, FAT12, FAT16 and FAT32. The other file system EFS, is a proprietary file system developed by SEGGER. The choice of the suitable file system depends on the environment in which the end application is to operate.

The FAT file system was developed by Microsoft to manage file segments, locate available clusters and reassemble files for use. Released in 1976, the first version of the FAT file system was FAT12, which is no longer widely used. It was created for extremely small storage devices. (The early version of FAT12 did not support managing directories).

FAT16 is good for use on multiple operating systems because it is supported by all versions of Microsoft Windows, including DOS and Linux. The newest version, FAT32, improves upon the FAT16 file system by utilizing a partition/disk much more efficiently. It is supported by all Microsoft Windows versions newer than Windows 98 and as well on Linux based systems.

The EFS file system was added to emFile as an alternative to the FAT file system and was specifically designed for embedded devices. This file system uses the storage space dedicated to the file and directory names more efficiently while still offering faster access to embedded storage devices. Another benefit of EFS is that there are no issues concerning long file name (LFN) support. The FAT file system was not designed for long file name support, limiting names to twelve characters (8.3 format). LFN support may be added to any of the FAT file systems. Long file names are inherent to this proprietary file system.

1.3.3 Fail safety

Fail safety is the feature of emFile that ensures the consistency of data in case of unexpected loss of power during a write access to a storage medium. emFile will be fail-safe only when both the file system (FAT/EFS) and the device driver are fail-safe. The journaling add-on of emFile makes the FAT/EFS file systems fail-safe. The device drivers of emFile are all fail-safe by design. You can find detailed information about how the fail-safety works in chapter *Journaling* on page 1297 and as part of the description of individual device drivers.

1.3.4 Wear leveling

This is a feature of the NAND and NOR flash device drivers that increase the lifetime of a storage medium by ensuring that all the storage blocks are equally well used. The flash storage memories have a limited number of program/erase cycles, typically around 100,000. The manufacturers do not guarantee that the storage device will work properly once this limit is exceeded. The wear leveling logic implemented in the device drivers tries to keep the number of program-erase cycles of a storage block as low as possible. You can find additional information in the description of the respective device drivers.

1.4 Implementation notes

This section provides information about the implementation of emFile

1.4.1 File system configuration

The file system is designed to be configurable at runtime. This has various advantages. Most of the configuration is done automatically; the linker builds in only code that is required. This concept allows to put the file system in a library. The file system does not need to be recompiled when the configuration changes, e.g. a different driver is used. Compile time configuration is kept to a minimum, primarily to select the level of multitasking support and the level of debug information. For detailed information about configuration of emFile, refer to *Configuration of emFile* on page 1218.

1.4.2 Runtime memory requirements

Because the configuration is selected at runtime the amount of memory required is not known at compile-time. For this reason a mechanism for runtime memory assignment is required. Runtime memory is typically allocated when required during the initialization and in most embedded systems never freed.

1.4.3 Initializing the file system

The first thing that needs to be done after the system start-up and before any file system function can be used, is to call the function `FS_Init()`. This routine initializes the internals of the file system. While initializing the file system, you have to add your target device to the file system. The function `FS_X_AddDevices()` adds and initializes the device.

```
FS_Init()
|
+--> FS_X_AddDevices()
    |
    +--> FS_AssignMemory()
        |
        +--> FS_AddDevice()
            |
            +--> Optional: Other configuration functions
```

1.4.4 Development environment (compiler)

The CPU used is of no importance; only an ANSI-compliant C compiler complying with at least one of the following international standards is required:

- ISO/IEC/ANSI 9899:1990 (C90) with support for C++ style comments (//)
- ISO/IEC 9899:1999 (C99)
- ISO/IEC 14882:1998 (C++)

If your compiler has some limitations, let us know and we will inform you if these will be a problem when compiling the software. Any compiler for 16/32/64-bit CPUs or DSPs that we know of can be used; most 8-bit compilers can be used as well. A C++ compiler is not required, but can be used. The application program can therefore also be programmed in C++ if desired.

Chapter 2

Getting started

This chapter provides an introduction to using emFile. It explains how to use the Windows sample, which is an easy way to get a first project with emFile up and running.

2.1 Package content and installation

emFile is provided in source code and contains everything needed to compile it on any platform. The following table shows the contents of the emFile package:

Files	Description
Application	Sample applications.
BSP	Support files for different evaluation boards
Config	Configuration header files.
Doc	emFile documentation.
FS	emFile source code.
Inc	Global header files.
Linux	Utility applications for Linux.
Sample	Sample drivers and applications.
SEGGER	Utility source code.
Simulation	Support files for PC simulation.
Windows	Utility applications for Windows.
FS_Start.*	PC simulation project MS Visual Studio / C++ and FAT.
FS_EFS_Start.*	PC simulation project MS Visual Studio / C++ and EFS.
FS_STORAGE_Start.*	PC simulation project MS Visual Studio / C++ and storage layer.

emFile is shipped in electronic form in a `.zip` file. In order to install it, extract the `.zip` file to any folder of your choice, preserving the directory structure of the `.zip` file.

2.2 Using the Windows sample application

If you have MS Visual C++ 6.00 or any later version available, you will be able to work with a Windows sample project using emFile. Even if you do not have the Microsoft compiler, you should read this chapter in order to understand how an application can use emFile.

2.2.1 Building the sample application

Open the workspace `FS_Start.sln` with MS Visual Studio (for example double-clicking it). There is no further configuration necessary. You should be able to build the application without any error or warning message.

2.2.2 Overview of the sample application

The sample project uses the RAM disk driver for demonstration. The main function of the sample application `Start.c` calls the function `MainTask()`. `MainTask()` initializes the file system and executes some basic file system operations. The sample application `Start.c` step-by-step:

```
void main(void);
void main(void) {
    MainTask();
}
```

```
void MainTask(void) {
    U32      v;
    FS_FILE  * pFile;
    char     ac[256];
    char     acFileName[32];
    const char * sVolumeName = "";

    FS_X_Log("Start\n");
    //
    // Initialize file system
    //
    FS_Init();
    //
    // Check if low-level format is required
    //
    FS_FormatLLIfRequired(sVolumeName);
    //
    // Check if volume needs to be high level formatted.
    //
    if (FS_IsHLFormatted(sVolumeName) == 0) {
        FS_X_Log("High-level format\n");
        FS_Format(sVolumeName, NULL);
    }
    sprintf(ac, "Running sample on \"%s\"\n", sVolumeName);
    FS_X_Log(ac);
    v = FS_GetVolumeFreeSpaceKB(sVolumeName);
    if (v < 0x8000) {
        sprintf(ac, " Free space: %lu KBytes\n", v);
    } else {
        v >>= 10;
        sprintf(ac, " Free space: %lu MBytes\n", v);
    }
    FS_X_Log(ac);
    sprintf(acFileName, "%s\\File.txt", sVolumeName);
    sprintf(ac, " Write test data to file %s\n", acFileName);
    FS_X_Log(ac);
    pFile = FS_FOpen(acFileName, "w");
    if (pFile) {
        FS_Write(pFile, "Test", 4);
    }
}
```

```

    FS_FClose(pFile);
} else {
    sprintf(ac, "Could not open file: %s to write.\n", acFileName);
    FS_X_Log(ac);
}
v = FS_GetVolumeFreeSpaceKB(sVolumeName);
if (v < 0x8000) {
    sprintf(ac, "  Free space: %lu KBytes\n", v);
} else {
    v >>= 10;
    sprintf(ac, "  Free space: %lu MBytes\n", v);
}
FS_X_Log(ac);
FS_Unmount(sVolumeName);
FS_X_Log("Finished\n");
while (1) {
    ;
}
}
}

```

❶ Application start

main.c calls MainTask().

❷ File system initialization

MainTask() initializes and adds a device to emFile.

❸ Low-level formatting

Checks if volume is low-level formatted and formats if required.

❹ High-level formatting

Checks if volume is high-level formatted and formats if required.

❺ Volume name

Outputs the volume name.

❻ Free space before operation

Calls FS_GetVolumeFreeSpace() and outputs the return value - the available free space of the RAM disk - to console window.

❼ File creation

Creates and opens a file test with write access (File.txt) on the device.

❽ File write

Writes 4 bytes into the file and closes the file handle or outputs an error message.

❾ Free space after operation

Calls FS_GetVolumeFreeSpace() and outputs the return value - the available free space of the RAM disk - again to console window.

❿ End of application

Outputs a quit message and runs into an endless loop.

2.2.3 Stepping through the sample application

❶ Application start

After starting the debugger by stepping into the application, your screen should look like the screenshot below. The main function calls MainTask().

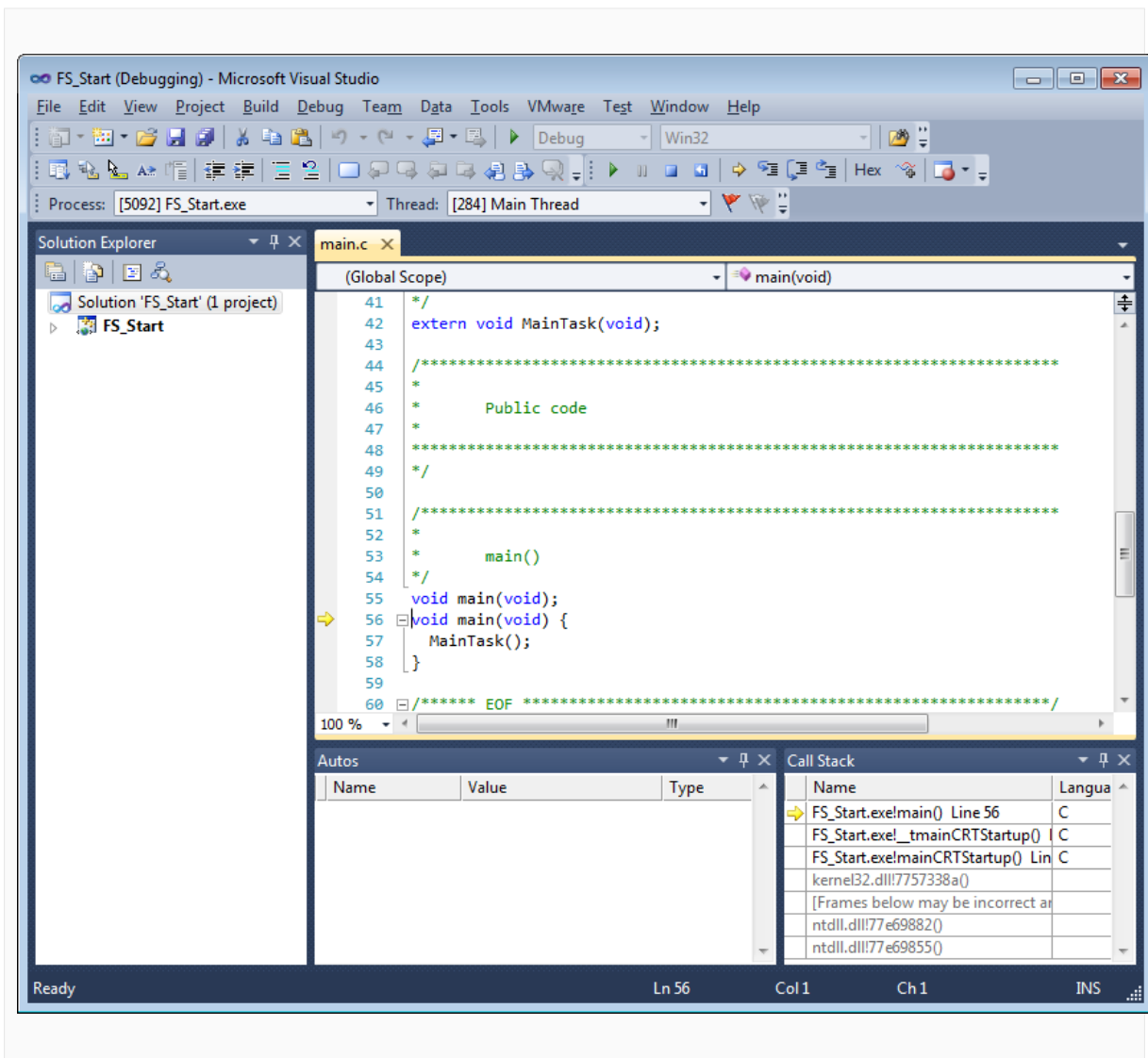

Application start

2 File system initialization

The first thing called from `MainTask()` is the emFile function `FS_Init()`. This function initializes the file system and calls `FS_X_AddDevices()`. The function `FS_X_AddDevices()` is used to add and configure the used device drivers to the file system. In the example configuration only the RAM disk driver is added. `FS_Init()` must be called before using any other emFile function. You should step over this function.

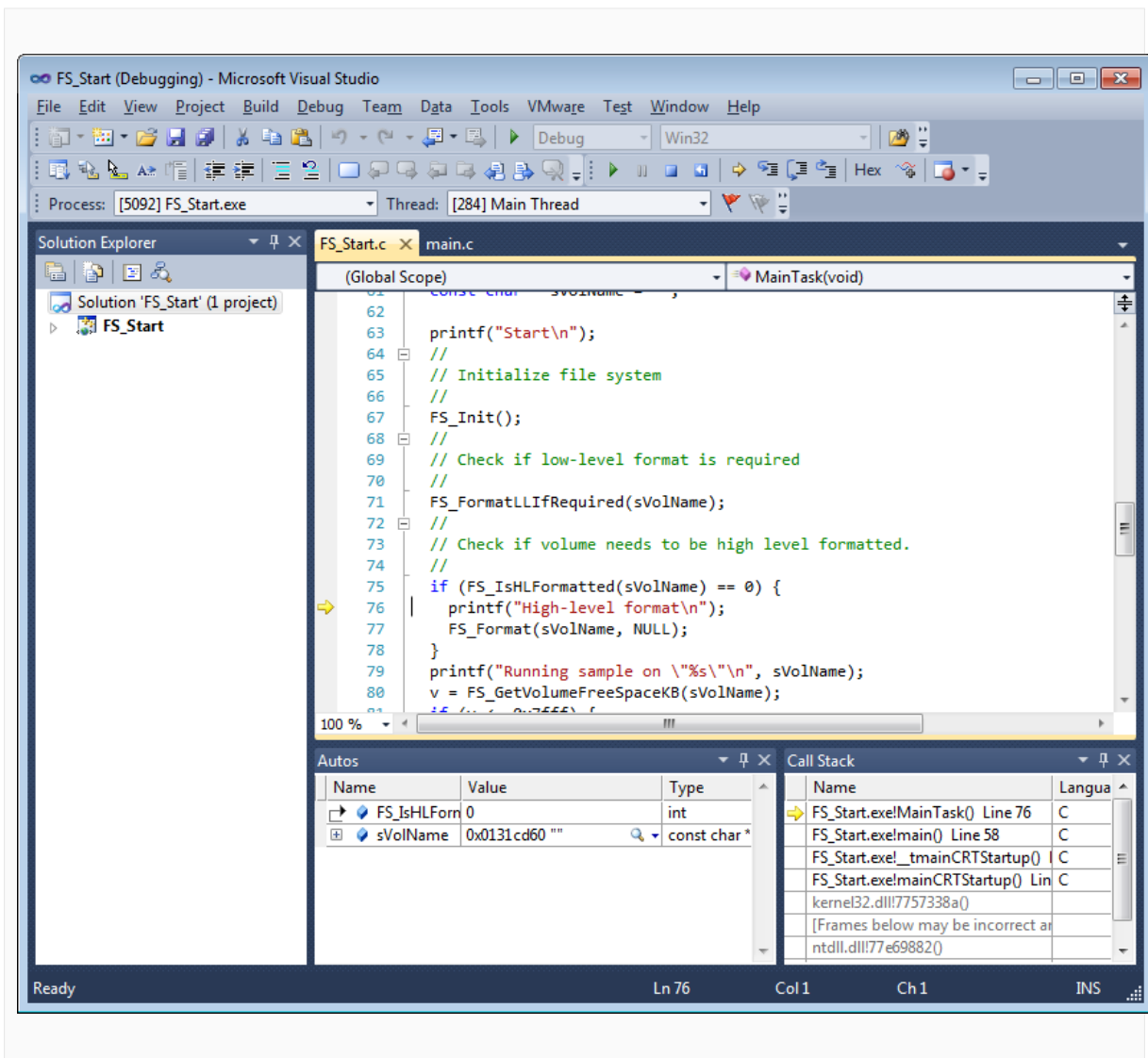

File system initialization

3 Low-level formatting

If the initialization was successful, `FS_FormatLLIfRequired()` is called. It checks if the volume is low-level formatted and formats the volume if required. You should step over this function.

4 High-level formatting

Afterwards `FS_IsHlFormatted()` is called. It checks if the volume is high-level formatted and formats the volume if required. You should step over this function.

5 Volume name

The volume name is printed in the console window.

6 Free space before operation

The `emFile` function `FS_GetVolumeFreeSpace()` is called and the return value is written into the console window.

7 File creation

Afterwards, you should get to the `emFile` function call `FS_FOpen()`. This function creates a file named `File.txt` in the root directory of your RAM disk. Stepping over this function should return the address of an `FS_FILE` structure. In case of any error, it would return 0, indicating that the file could not be created.

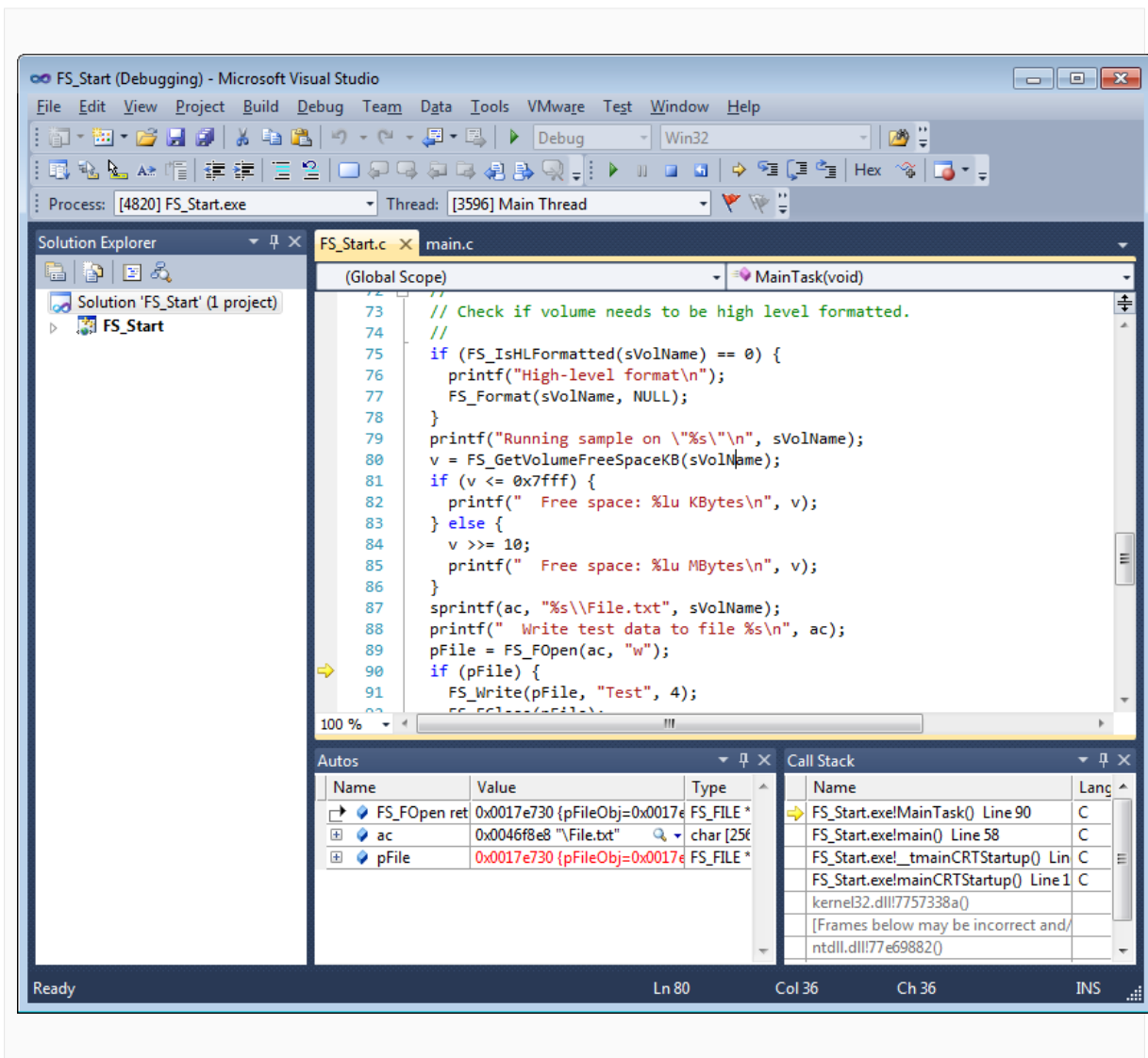

File creation

8 File write

If `FS_FOpen()` returns a valid pointer to an `FS_FILE` structure, the sample application will write a small ASCII string to this file by calling the emFile function `FS_Write()`. Step over this function. If a problem occurs, compare the return value of `FS_Write()` with the length of the ASCII string, which should be written. `FS_Write()` returns the number of elements which have been written. If no problem occurs the function emFile function `FS_FClose()` should be reached. `FS_FClose()` closes the file handle for `File.txt`. Step over this function.

9 Free space after operation

Continue stepping over until you reach the place where the function `FS_GetVolumeFreeSpace()` is called. The emFile function `FS_GetVolumeFreeSpace()` returns available free drive space in bytes. After you step over this function, the variable `v` should have a value greater than zero.

10 End of application

The return value is written in the console window.

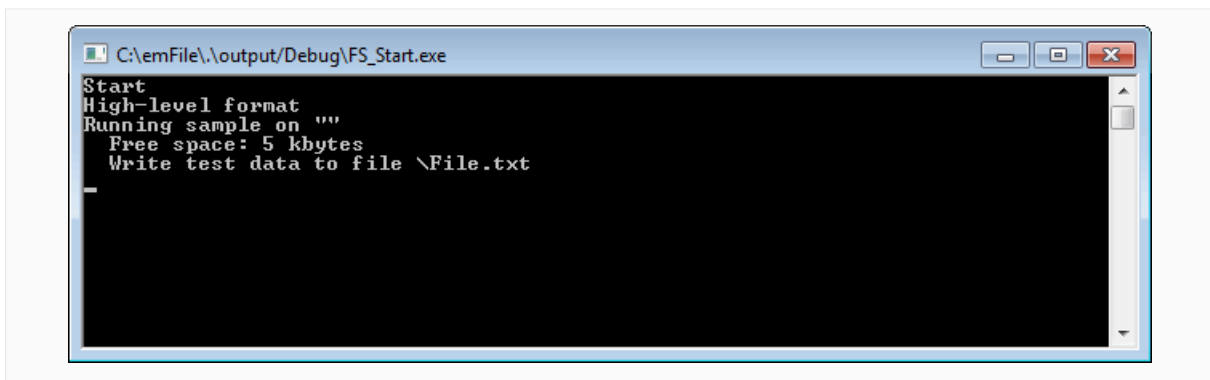
A screenshot of a Windows command prompt window. The title bar reads "C:\emFile\output\Debug\F5_Start.exe". The window contains the following text:

```
Start
High-level format
Running sample on ""
  Free space: 5 kbytes
  Write test data to file \File.txt
-
```

End of application

2.3 Further source code examples

Further source code examples which demonstrate directory operations and performance measuring are available. All emFile source code examples are located in the `Sample/FS/Application` folder of the emFile shipment.

2.4 Recommended project structure

We recommend keeping emFile separate from your application files. It is good practice to keep all the program files (including the header files) together in the `FS` subdirectory of your project's root directory. This practice has the advantage of being very easy to update to newer versions of emFile by simply replacing the `FS` directory. Your application files can be stored anywhere.

Warning

When updating to a newer emFile version as files may have been added, moved or deleted, the project directories may need to be updated accordingly.

Warning

Always make sure that you have only one version of each file!

It is frequently a major problem when updating to a new version of emFile if you have old files included and therefore mix different versions. If you keep emFile in the directories as suggested (and only in these), this type of problem cannot occur. When updating to a newer version, you should be able to keep your configuration files and leave them unchanged. For safety reasons, we recommend backing up (or at least renaming) the `FS` directories before updating.

Chapter 3

Running emFile on target hardware

This chapter explains how to integrate and run emFile on your target hardware. It explains this process step-by-step.

3.1 Integrating emFile

The default configuration of emFile contains a single storage device: a RAM disk. This should always be the first step to check if emFile functions properly on your target hardware. We assume that you are familiar with the tools you have selected for your development (compiler, project manager, linker, etc.). You should therefore be able to add files, add directories to the include search path, and so on. It is also assumed that you are familiar with the OS that you will be using on your target system (if you are using one). The SEGGER Embedded Studio IDE (<https://www.segger.com/embedded-studio.html>) is used in this document for all examples and screenshots, but every other ANSI C toolchain can also be used. It is also possible to use makefiles; in this case, when we say “add to the project”, this translates into “add to the makefile”.

3.2 Procedure to follow

Integration of emFile is a relatively simple process, which consists of the following steps:

- Step 1: Creating a start project without emFile.
- Step 2: Adding emFile to the start project.
- Step 3: Adding the device driver.
- Step 4: Activating the driver.
- Step 5: Adjusting the RAM usage.

3.3 Step 1: Creating a simple project without emFile

We recommend that you create a small "hello world" program for your system. That project should already use your OS and there should be a way to display text on a screen or serial port. If you are using the SEGGER embOS (<https://www.segger.com/products/rtos/embos/>), you can use the start project shipped with the embOS for this purpose.

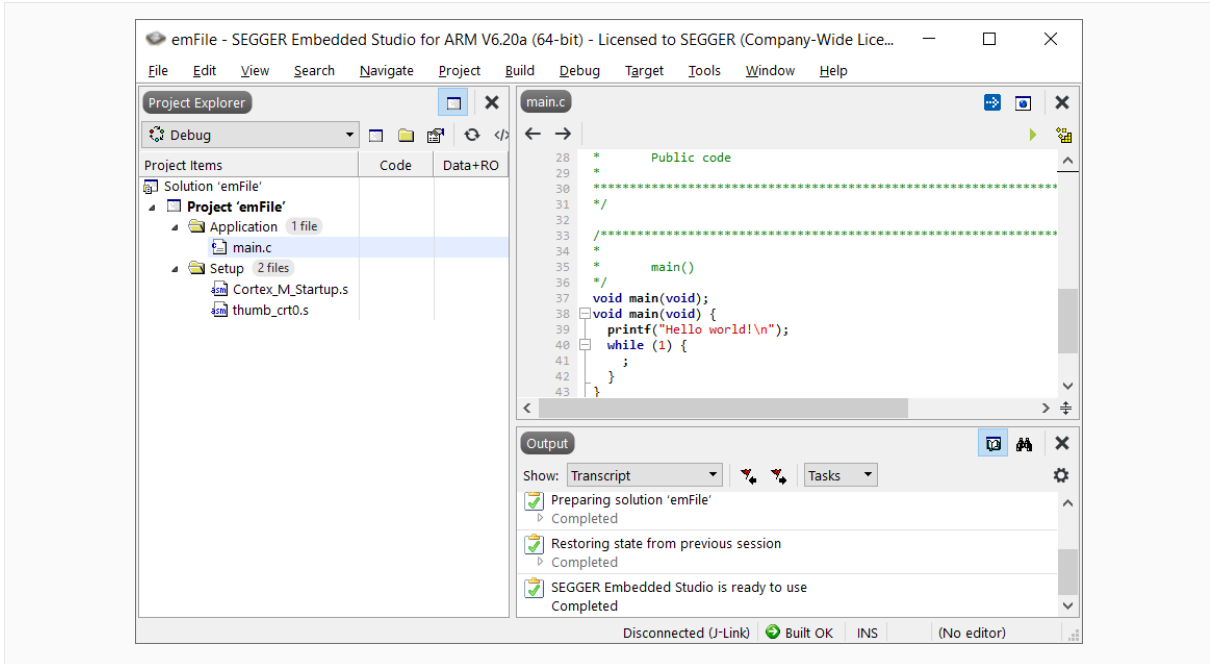

Start project

3.4 Step 2: Adding emFile to the start project

Add all source files from the following directories (and their subdirectories) to your project:

- Application (Only one file located in this directory has to be included)
- Config
- FS
- Sample/FS/OS (Only one file located in this directory has to be included and only if the application uses an RTOS. The included file must be compatible with the RTOS used).
- SEGGER

It is recommended to keep the provided folder structure.

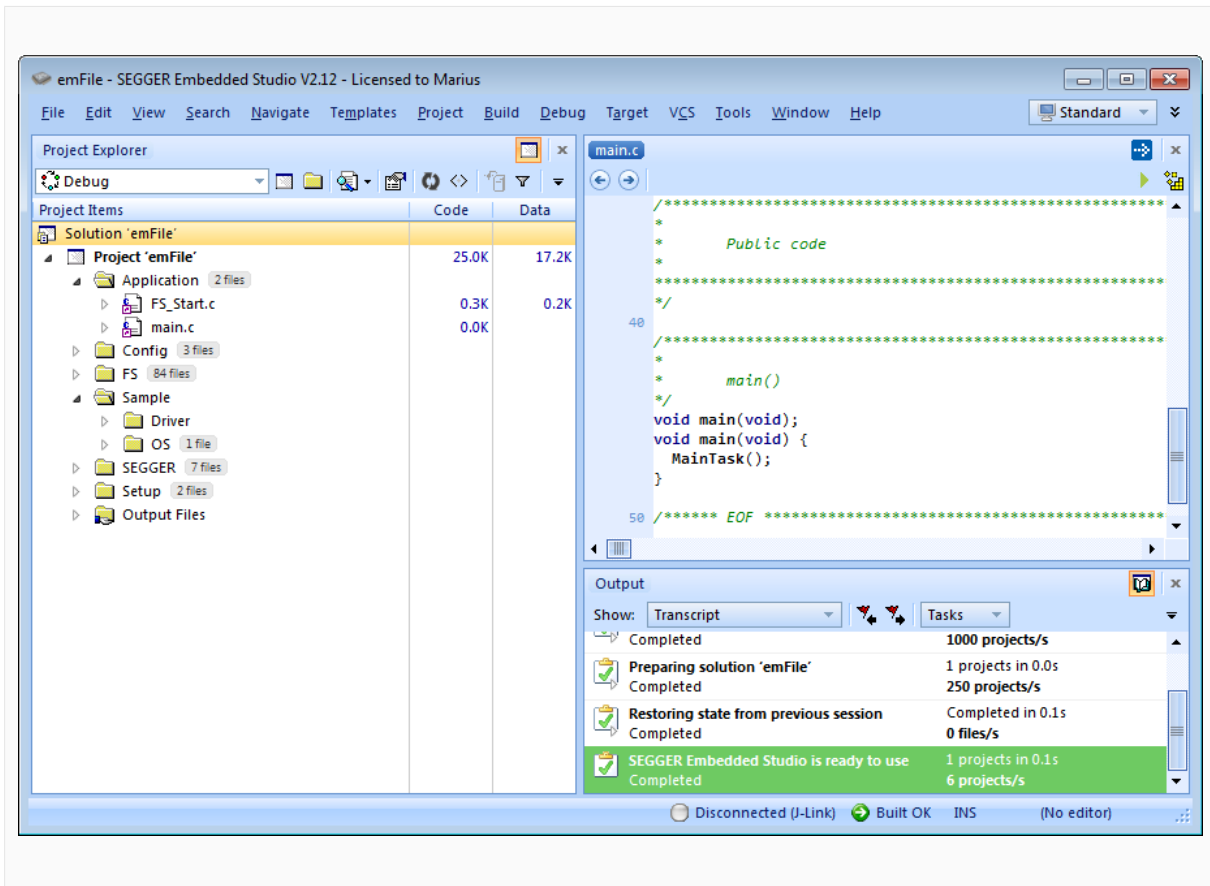

Add source files

3.4.1 Configuring the include path

The include path is the path in which the compiler looks for include files. In cases where the included files (typically header files, .h) do not reside in the same directory as the C file to compile, an include path needs to be set. In order to build the project with all added files, you will need to add the following directories to your include path:

- Config
- FS
- SEGGER

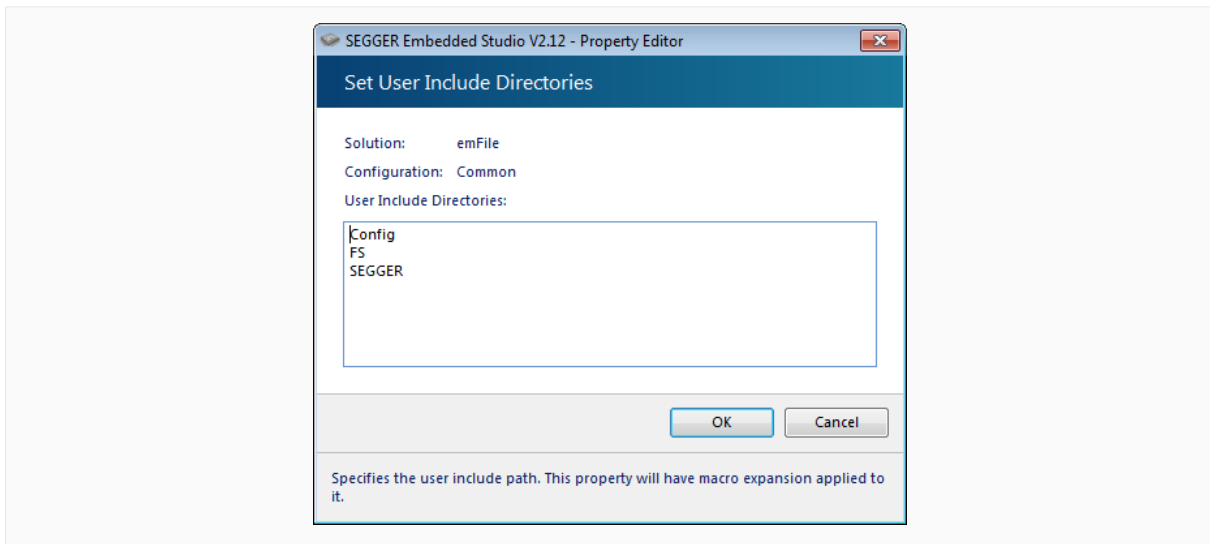

Include paths

3.4.2 Select the start application

For quick and easy testing of your emFile integration, start with the code found in the `Application` folder of the shipment. Exclude all files in the `Application` folder of your project except the supplied `main.c` and `FS_Start.c` files. The application performs the following steps:

- `main.c` calls `MainTask()`.
- `MainTask()` initializes and adds a device to file system.
- Checks if volume is low-level formatted and formats if required.
- Checks if volume is high-level formatted and formats if required.
- Outputs the volume name.
- Calls `FS_GetVolumeFreeSpace()` and outputs the return value -- the available total space of the RAM disk -- to console window.
- Creates and opens a file test with write access (`File.txt`) on the storage device
- Writes 4 bytes of data into the file and closes the file handle or outputs an error message.
- Calls `FS_GetVolumeFreeSpace()` and outputs the return value -- the available free space of the RAM disk -- again to console window.
- Outputs a quit message and runs into an endless loop.

3.4.3 Build the project and test it

Build the project. It should compile without errors and warnings. If you encounter any problem during the build process, check your include path and your project configuration settings. The start application should print out the storage space of the device twice, once before a file has been written to the device and once afterwards.

3.5 Step 3: Adding the device driver

To configure emFile with a device driver, two modifications have to be performed:

- Adding device driver source to project.
- Adding hardware routines to project.

Each step is explained in the following sections. For example, the implementation of the MMC/SD driver is shown, but all steps can easily be adapted to every other device driver implementation.

3.5.1 Adding the device driver source to project

Add the driver sources to the project and add the directory to the include path.

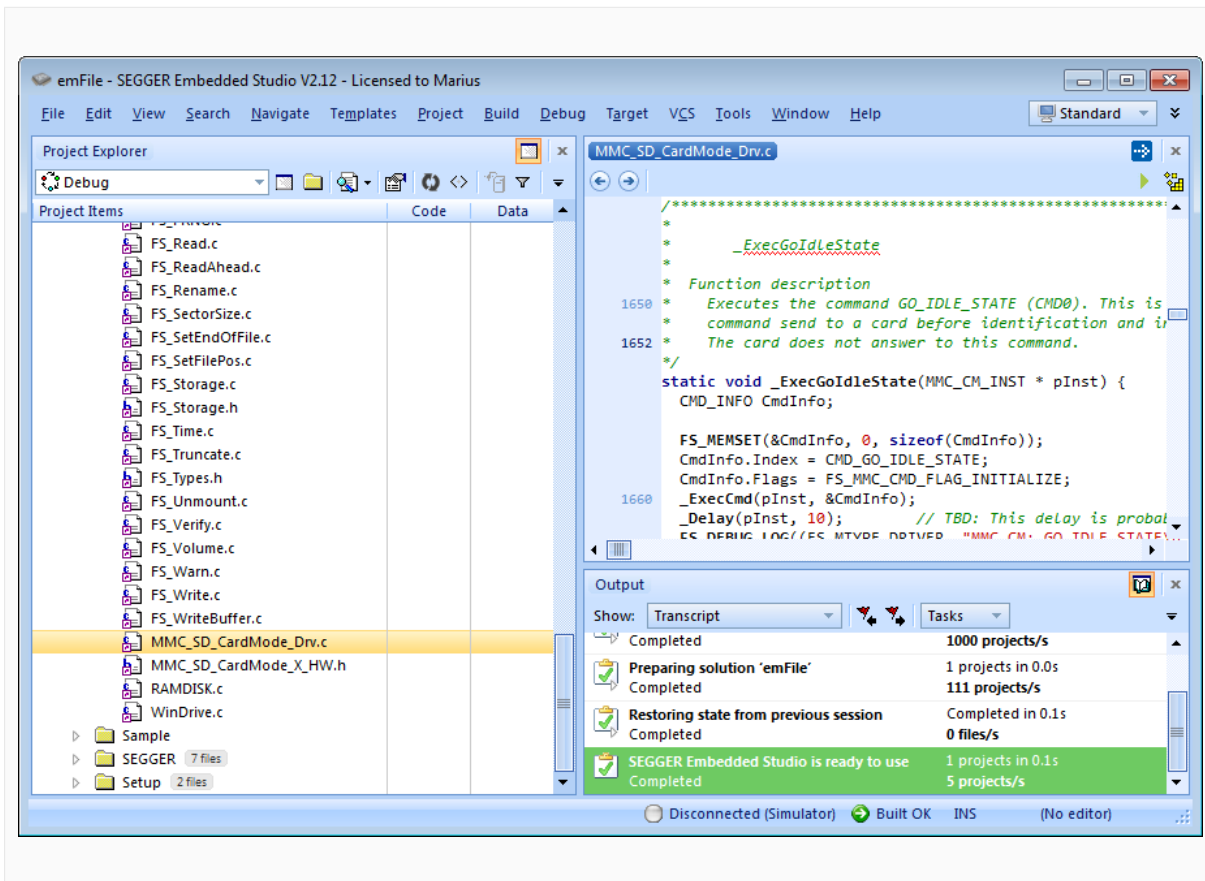

Add device driver

Most drivers require additional hardware routines to work with the specific hardware. If your driver requires low-level I/O routines to access the hardware, you will have to provide them. Drivers which require hardware routines are:

- NAND flash
- NOR flash with serial devices
- MMC/SD cards
- Compact flash / IDE Drivers which do not require hardware routines are:
- NOR flash with CFI compliant devices
- RAM disk

Nearly all drivers have to be configured before they can be used. The runtime configuration functions which specify for example the memory addresses and the size of memory are located in the configuration file of the respective driver. All required configurations are explained in the configuration section of the respective driver. If you use one of the drivers which do not require hardware routines skip the next section and refer to *Step 4: Activating the driver* on page 59.

3.5.2 Adding hardware routines to project

A template with empty function bodies and in most cases one or more sample implementations are supplied for every driver that requires hardware routines. The easiest way to start is to use one of the ready-to-use samples. The ready-to-use samples can be found in the subfolders `Sample/FS/Driver/<DRIVER_DIR>` of the emFile shipment where `DRIVER_DIR` is the type of the device driver. You should check the `Readme.txt` file located in the driver directory to see which samples are included. If there is one which is a good or close match for your hardware, it should be used. Otherwise, use the template to implement the hardware routines. The template is a skeleton driver which contains empty implementations of the required functions and is the ideal base to start the implementation of hardware specific I/O routines. What to do Copy the compatible hardware function sample or the template into a subdirectory of your work directory and add it to your project. The template file is located in the `Sample/FS/Driver/<DRIVER_DIR>` folder; the example implementations are located in the respective directories. If you start the implementation of hardware routines with the hardware routine template, refer to *Device drivers* on page 389 for detailed information about the implementation of the driver specific hardware functions, else refer to section *Step 4: Activating the driver* on page 59.

Note

You cannot run and test the project with the new driver on your hardware as long as you have not added the proper configuration file for the driver to your project. Refer to section *Step 4: Activating the driver* on page 59 for more information about the activation of the driver with the configuration file.

3.6 Step 4: Activating the driver

After adding the driver source, and if required the hardware function implementation, copy the `FS_Config<DRIVER_NAME>.c` file (for example, `FS_ConfigMMC_CardMode.c` for the MMC/SD card driver using card mode) into the `Config` folder of your `emFile` work directory and add it to your project.

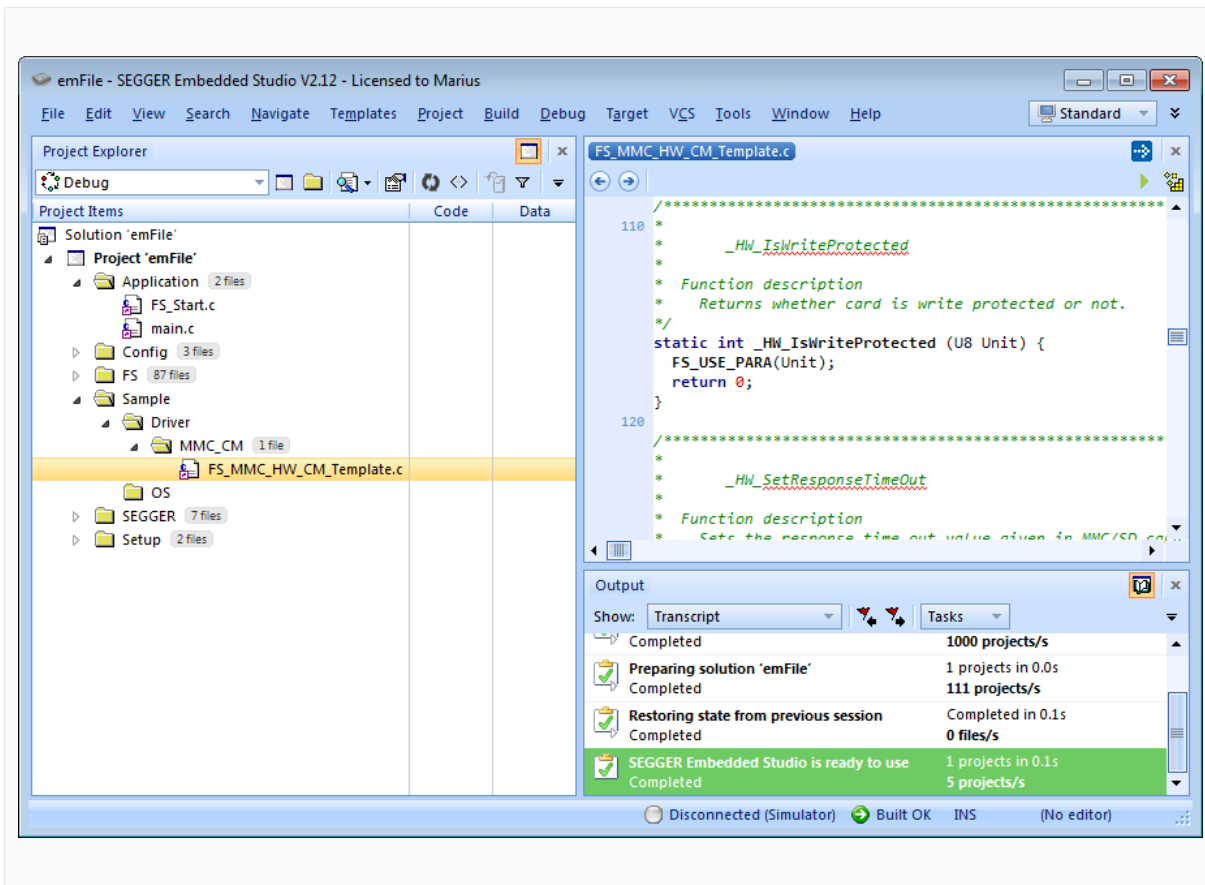

Add template driver

The configuration files contain, all the runtime configuration functions of the file system. The configuration files include a start configuration which allows a quick and easy start with every driver. The most important function for the beginning is `FS_X_AddDevices()`. It activates and configures the driver, if required. A driver which does not require hardware routines has to be configured before it can be used.

3.6.1 Modifying the runtime configuration

The following example a single CFI compliant NOR flash chip with a 16-bit interface and a size of 256 Mbytes to the file system. The base address, the start address and the size of the NOR flash are defined using the macros `FLASH0_BASE_ADDR`, `FLASH0_START_ADDR` and `FLASH0_SIZE`. Normally, only the "Defines, configurable" section of the configuration files requires changes for typical embedded systems. The "Public code" section which includes the time and date functions and `FS_X_AddDevices()` does not require modifications on most systems.

```

/*****
 *
 *   Defines, configurable
 *
 *   This section is the only section which requires changes for
 *   typical embedded systems using the NOR flash driver with a
 *   single device.
 *
 *****/

```

```

#define ALLOC_SIZE          0x10000          // Size of memory dedicated to the file
// system. This value should be fine-tuned
// according for your system.
#define FLASH0_BASE_ADDR   0x40000000      // Base address of the NOR flash device
// to be used as storage
#define FLASH0_START_ADDR  0x40000000      // Start address of the first sector
// to be used as storage. If the entire
// device is used for file system,
// it is identical to
// the base address.
#define FLASH0_SIZE        0x200000        // Number of bytes to be used for storage

/*****
 *
 *      Static data.
 *
 *      This section does not require modifications in most systems.
 *****/
*/
static U32 _aMemBlock[ALLOC_SIZE / 4];      // Memory pool used for semi-dynamic
// allocation in FS_AssignMemory().
/*****
 *
 *      Public code
 *
 *      This section does not require modifications in most systems.
 *****/
*/

/*****
 *
 *      FS_X_AddDevices
 *
 *      Function description
 *      This function is called by the FS during FS_Init().
 *      It is supposed to add all devices, using primarily FS_AddDevice().
 */
void FS_X_AddDevices(void) {
    FS_AssignMemory(&_aMemBlock[0], sizeof(_aMemBlock));
    //
    // Add driver the NOR driver.
    //
    FS_AddDevice(&FS_NOR_Driver);
    //
    // Configure the NOR flash interface.
    //
    FS_NOR_SetPhyType(0, &FS_NOR_PHY_CFI_1x16);
    FS_NOR_Configure(0, FLASH0_BASE_ADDR, FLASH0_START_ADDR, FLASH0_SIZE);
    //
    // Configure a read buffer for the file data.
    //
    FS_ConfigFileBufferDefault(512, 0);
}

```

After the driver has been added, the configuration functions (in this example `FS_NOR_SetPhyType()` and `FS_NOR_Configure()`) should be called. Detailed information about the driver configuration can be found in the configuration section of the respective driver. Refer to section *Runtime configuration* on page 395 for detailed information about the other runtime configurations of the file system. Before compiling and running the sample application with the added driver, you have to exclude `FS_ConfigRAMDisk.c` from the project.

Note

For the drivers which required hardware access routines, if you have only added the template with empty function bodies until now, the project should compile without errors or warning messages. But you can only run the project on your hardware if you have finished the implementation of the hardware functions.

3.7 Step 5: Adjusting the RAM usage

The file system needs RAM for management purposes in various places. The amount of RAM required depends primarily on the configuration, especially the drivers used. The drivers which have their own level of management (such as NOR / NAND drivers) require in general more RAM than the "simple" drivers such as for hard drives, compact flash or MMC/SD cards. Every driver needs to allocate RAM. The file system allocates RAM in the initialization phase and holds it while the file system is running. The macro `ALLOC_SIZE` which is located in the respective driver configuration file specifies the size of RAM used by the file system. This value should be fine-tuned according to the requirements of your target system.

Per default, `ALLOC_SIZE` is set to a value which should be appropriate for most target systems. Nevertheless, you should adjust it in order to avoid wasting too much RAM. Once your file system project is up and running, you can check the real RAM requirement of the driver via the public variable `FS_Global.MemManager.NumBytesAllocated`. Check the value of `FS_Global.MemManager.NumBytesAllocated` after the initialization of the file system and after a volume has been mounted. At this point `FS_Global.MemManager.NumBytesAllocated` can be used as reference for the dynamic memory usage of emFile. You should reserve a few more bytes for emFile as the value of `FS_Global.MemManager.NumBytesAllocated` is at this point, since every file which is opened needs dynamic memory for maintenance information. For more information about resource usage of the file handlers, please refer to *Dynamic RAM usage* on page 397.

Note

If you define `ALLOC_SIZE` with a value which is smaller than the appropriate size, the file system will run into `FS_X_Panic()`. If you define `ALLOC_SIZE` with a value which is above the limits of your target system, the linker will give an error during the build process of the project.

Chapter 4

API functions

This chapter provides a detailed description of emFile API layer.

4.1 General information

Any functions or data structures that are not described in this chapter but are exposed through inclusion of the `FS.h` header file must be considered private and subject to change.

4.1.1 Volume, file and directory names

A volume, file or directory name is a 0-terminated string the application can use as a parameter to an API function (such as `FS_FOpen()`) to identify a volume, file or directory the API function has to operate on.

A file or directory name contains the following mandatory and optional elements where the optional elements are surrounded by `[]`:

```
[VolumeName:[UnitNo:]][DirPath]FileName|DirName
```

- `VolumeName` is the name of the volume on which the file or directory is located. If not specified, the first configured volume is assumed.
- `UnitNo` is the index of the volume on which the file or directory is located. If not specified, the index 0 is assumed. It is not allowed to specify a unit number if volume name has not been specified.
- `DirPath` is the complete directory path to an already existing subdirectory. `DirPath` has to start and end with a directory delimiter character. The names of directories in the path are also separated by directory delimiter. The directory delimiter character can be configured at compile time via `FS_DIRECTORY_DELIMITER` configuration define. The default directory delimiter is the `'\'` character. The root directory is assumed if `DirPath` is not specified. `emFile` does not support relative file or directory names therefore the application has to always specify the full path a to a file or directory.
- `FileName` or `DirName` is the name of the file or directory that has to be accessed by the file system. If volume is formatted as FAT and the support for long file name is not enabled, all file and directory names directory names have to follow the standard FAT 8.3 naming convention. The same applies to the directory names in `DirPath`. EFS comes with native support for long file names. The length of a file or directory name is limited to 235 valid characters.

A volume name contains the following mandatory and optional elements where the optional elements are surrounded by `[]`:

```
VolumeName:[UnitNo:]
```

`VolumeName` and `UnitNo` have the same meaning as described above.

Examples

The following examples specify the same file name assuming that the first driver added to file system is the NAND driver.

- `"DirName\FileName.txt"`
- `"nand:\DirName\FileName.txt"`
- `"nand:0:\DirName\FileName.txt"`

The following examples specify the same volume name assuming that the first driver added to file system is the NOR driver.

- `""`
- `"nor"`
- `"nor:0:"`

4.2 API function overview

The table below lists the available API functions within their respective categories.

Function	Description
File system control functions	
<code>FS_Init()</code>	Starts the file system.
<code>FS_DeInit()</code>	Frees allocated resources.
<code>FS_Mount()</code>	Initializes a volume in default access mode.
<code>FS_MountEx()</code>	Initializes a volume in a specified access mode.
<code>FS_SetAutoMount()</code>	Sets the automatic mount behavior.
<code>FS_Sync()</code>	Saves cached information to storage.
<code>FS_Unmount()</code>	Synchronizes the data and marks the volume as not initialized.
<code>FS_UnmountForced()</code>	Marks the volume as not initialized.
File system configuration functions	
<code>FS_AddDevice()</code>	Adds a driver to file system.
<code>FS_AddPhysDevice()</code>	Adds a device to file system without assigning a volume to it.
<code>FS_AssignMemory()</code>	Assigns a memory pool to the file system.
<code>FS_ConfigFileBufferDefault()</code>	Configures the size and flags for the file buffer.
<code>FS_LOGVOL_Create()</code>	Creates a driver instance.
<code>FS_LOGVOL_AddDevice()</code>	Adds a storage device to a logical volume.
<code>FS_SetFileBufferFlags()</code>	Changes the operating mode of the file buffer.
<code>FS_SetFileBufferFlagsEx()</code>	Changes the operating mode of the file buffer.
<code>FS_SetFileWriteMode()</code>	Configures the file write mode.
<code>FS_SetFileWriteModeEx()</code>	Configures the write mode of a specified volume.
<code>FS_SetMemHandler()</code>	Configures functions for memory management.
<code>FS_SetMaxSectorSize()</code>	Configures the maximum size of a logical sector.
File access functions	
<code>FS_FClose()</code>	Closes an opened file.
<code>FS_FGets()</code>	Reads a line of text from file.
<code>FS_FOpen()</code>	Opens an existing file or creates a new one.
<code>FS_FOpenEx()</code>	Opens an existing file or creates a new one.
<code>FS_FPrintf()</code>	Writes a formatted string to a file.
<code>FS_FPuts()</code>	Writes a 0-terminated string to a file.
<code>FS_FRead()</code>	Reads data from file.
<code>FS_FSeek()</code>	Sets the current position in file.
<code>FS_FWrite()</code>	Writes data to file.

Function	Description
<code>FS_FTell()</code>	Returns current position in file.
<code>FS_GetFileSize()</code>	Returns the size of a file.
<code>FS_GetFileSizeEx()</code>	Returns the size of a file.
<code>FS_Read()</code>	Reads data from a file.
<code>FS_SetEndOfFile()</code>	Sets the file size to current file position.
<code>FS_SetFileSize()</code>	Sets the file size to the specified number of bytes.
<code>FS_SyncFile()</code>	Synchronizes file to storage device.
<code>FS_Truncate()</code>	Changes the size of a file.
<code>FS_Verify()</code>	Verifies the file contents.
<code>FS_Write()</code>	Writes data to file.
Operations on files	
<code>FS_CopyFile()</code>	Copies a file.
<code>FS_CopyFileEx()</code>	Copies a file.
<code>FS_GetFileAttributes()</code>	Queries the attributes of a file or directory.
<code>FS_GetFileInfo()</code>	Returns information about a file or directory.
<code>FS_GetFileTime()</code>	Returns the creation time of a file or directory.
<code>FS_GetFileTimeEx()</code>	Gets the timestamp of a file or directory.
<code>FS_ModifyFileAttributes()</code>	Sets / clears the attributes of a file or directory.
<code>FS_Move()</code>	Moves a file or directory to another location.
<code>FS_Remove()</code>	Removes a file.
<code>FS_Rename()</code>	Changes the name of a file or directory.
<code>FS_SetFileAttributes()</code>	Modifies all the attributes of a file or directory.
<code>FS_SetFileBuffer()</code>	Assigns a file buffer to an opened file.
<code>FS_SetFileTime()</code>	Sets the creation time of a file or directory.
<code>FS_SetFileTimeEx()</code>	Sets the timestamp of a file or directory.
<code>FS_WipeFile()</code>	Overwrites the contents of a file with random data.
Directory functions	
<code>FS_CreateDir()</code>	Creates a directory including any missing directories from path.
<code>FS_DeleteDir()</code>	Removes a directory and its contents.
<code>FS_FindClose()</code>	Ends a directory scanning operation.
<code>FS_FindFirstFile()</code>	Initiates a directory scanning operation and returns information about the first file or directory.
<code>FS_FindNextFile()</code>	Returns information about the next file or directory in a directory scanning operation.
<code>FS_FindNextFileEx()</code>	Returns information about the next file or directory in a directory scanning operation.
<code>FS_MkDir()</code>	Creates a directory.

Function	Description
<code>FS_RmDir()</code>	Removes a directory.
Formatting functions	
<code>FS_Format()</code>	Performs a high-level format.
<code>FS_FormatLLIfRequired()</code>	Performs a low-level format.
<code>FS_FormatLow()</code>	Performs a low-level format.
<code>FS_IsHLLFormatted()</code>	Checks if a volume is high-level formatted or not.
<code>FS_IsLLFormatted()</code>	Returns whether a volume is low-level formatted or not.
Partitioning functions	
<code>FS_CreateGPT()</code>	Partitions the specified volume using a GPT (GUID Partition Table) partition scheme.
<code>FS_CreateMBR()</code>	Partitions the specified volume using a MBR (Master Boot Record) partition scheme.
<code>FS_GetGPTInfo()</code>	Returns information about the GPT partitioning.
<code>FS_GetPartitionInfoMBR()</code>	Returns information about a MBR partition.
<code>FS_GetPartitionInfoGPT()</code>	Returns information about a GPT partition.
<code>FS_GetPartitioningScheme()</code>	Returns information about how a storage device is partitioned.
File system structure checking	
<code>FS_CheckAT()</code>	Verifies the consistency of the allocation table.
<code>FS_CheckDir()</code>	Verifies the consistency of a single directory.
<code>FS_CheckDisk()</code>	Checks the consistency of the file system structure.
<code>FS_CheckDisk_ErrCode2Text()</code>	Returns a human-readable text description of a disk checking error code.
<code>FS_InitCheck()</code>	Initializes a non-blocking disk checking operation.
File system extended functions	
<code>FS_ConfigEOFErrorSuppression()</code>	Enables / disables the reporting of end-of-file condition as error.
<code>FS_ConfigPOSIXSupport()</code>	Enables / disables support for the POSIX-like behavior.
<code>FS_ConfigWriteVerification()</code>	Enables / disables the verification of the written data.
<code>FS_FileTimeToTimeStamp()</code>	Converts a broken-down date and time specification to a timestamp.
<code>FS_FreeSectors()</code>	Informs the device driver about unused sectors.
<code>FS_GetAutoMount()</code>	Returns information about how a volume is automatically mounted.
<code>FS_GetFileId()</code>	Calculates a value that uniquely identifies a file.
<code>FS_GetFileWriteMode()</code>	Returns the write mode.

Function	Description
<code>FS_GetFileWriteModeEx()</code>	Returns the write mode configured for a specified volume.
<code>FS_GetFSType()</code>	Returns the type of file system assigned to volume.
<code>FS_GetMaxSectorSize()</code>	Queries the maximum configured logical sector size.
<code>FS_GetMemInfo()</code>	Returns information about the memory management.
<code>FS_GetMountType()</code>	Returns information about how a volume is mounted.
<code>FS_GetNumFilesOpen()</code>	Queries the number of opened file handles.
<code>FS_GetNumFilesOpenEx()</code>	Queries the number of opened file handles on a volume.
<code>FS_GetNumVolumes()</code>	Queries the number of configured volumes.
<code>FS_GetVolumeAlias()</code>	Returns the alternative name of a volume.
<code>FS_GetVolumeFreeSpace()</code>	Returns the free space available on a volume.
<code>FS_GetVolumeFreeSpaceFirst()</code>	Initiates the search for free space.
<code>FS_GetVolumeFreeSpaceKB()</code>	Returns the free space available on a volume.
<code>FS_GetVolumeFreeSpaceNext()</code>	Continues the search for free space.
<code>FS_GetVolumeInfo()</code>	Returns information about a volume.
<code>FS_GetVolumeInfoEx()</code>	Returns information about a volume.
<code>FS_GetVolumeLabel()</code>	Returns the label of the volume.
<code>FS_GetVolumeName()</code>	Returns the name of a volume.
<code>FS_GetVolumeSize()</code>	Returns the size of a volume.
<code>FS_GetVolumeSizeKB()</code>	Returns the size of a volume.
<code>FS_GetVolumeStatus()</code>	Returns the presence status of a volume.
<code>FS_IsVolumeMounted()</code>	Checks if a volume is mounted.
<code>FS_Lock()</code>	Claims exclusive access to file system.
<code>FS_LockVolume()</code>	Claims exclusive access to a volume.
<code>FS_SetBusyLEDCallback()</code>	Registers a callback for busy status changes of a volume.
<code>FS_SetCharSetType()</code>	Configures the character set that is used for the file and directory names.
<code>FS_SetFSType()</code>	Sets the type of file system a volume.
<code>FS_SetMemCheckCallback()</code>	Registers a callback for checking of 0-copy operations.
<code>FS_SetTimeDateCallback()</code>	Configures a function that the file system can use to get the current time and date.
<code>FS_SetVolumeAlias()</code>	Assigns an alternative name for a volume.
<code>FS_SetVolumeLabel()</code>	Modifies the label of a volume.
<code>FS_TimeStampToFileTime()</code>	Converts a timestamp to a broken-down date and time specification.
<code>FS_Unlock()</code>	Releases the exclusive access to file system.

Function	Description
<code>FS_UnlockVolume()</code>	Releases the exclusive access to a volume.
Storage layer functions	
<code>FS_STORAGE_Clean()</code>	Performs garbage collection on a volume.
<code>FS_STORAGE_CleanEx()</code>	Performs garbage collection on a volume.
<code>FS_STORAGE_CleanOne()</code>	Performs garbage collection on a volume.
<code>FS_STORAGE_CleanOneEx()</code>	Performs garbage collection on a volume.
<code>FS_STORAGE_DeInit()</code>	Frees the resources allocated by the storage layer.
<code>FS_STORAGE_FillSectors()</code>	Writes the same sector data to one or more logical sectors.
<code>FS_STORAGE_FillSectorsEx()</code>	Writes the same sector data to one or more logical sectors.
<code>FS_STORAGE_FindVolume()</code>	Searches for a volume instance by name.
<code>FS_STORAGE_FindVolumeByDevice()</code>	Searches for a volume instance by index.
<code>FS_STORAGE_FindVolumeByIndex()</code>	Searches for a volume instance by index.
<code>FS_STORAGE_FormatLowEx()</code>	Formats the storage device.
<code>FS_STORAGE_FreeSectors()</code>	Informs the driver about unused sectors.
<code>FS_STORAGE_FreeSectorsEx()</code>	Informs the driver about unused sectors.
<code>FS_STORAGE_GetAutoMountType()</code>	Returns information about how a volume is automatically mounted.
<code>FS_STORAGE_GetAutoMountTypeEx()</code>	Returns information about how a volume is automatically mounted.
<code>FS_STORAGE_GetCleanCnt()</code>	Calculates the number of garbage collection sub-operations.
<code>FS_STORAGE_GetCleanCntEx()</code>	Calculates the number of garbage collection sub-operations.
<code>FS_STORAGE_GetCounters()</code>	Returns the values of statistical counters.
<code>FS_STORAGE_GetDeviceInfo()</code>	Returns information about the storage device.
<code>FS_STORAGE_GetDeviceInfoEx()</code>	Returns information about the storage device.
<code>FS_STORAGE_GetMountType()</code>	Returns information about how a volume is mounted.
<code>FS_STORAGE_GetMountTypeEx()</code>	Returns information about how a volume is mounted.
<code>FS_STORAGE_GetSectorUsage()</code>	Returns information about the usage of a logical sector.
<code>FS_STORAGE_GetSectorUsageEx()</code>	Returns information about the usage of a logical sector.
<code>FS_STORAGE_GetVolumeStatusEx()</code>	Returns the presence status of a volume.
<code>FS_STORAGE_Init()</code>	Initializes the storage layer.
<code>FS_STORAGE_IsLLFormattedEx()</code>	Checks if a storage device is low-level formatted.
<code>FS_STORAGE_Mount()</code>	Initializes a volume in a specified access mode.
<code>FS_STORAGE_MountEx()</code>	Initializes a volume in a specified access mode.
<code>FS_STORAGE_ReadSector()</code>	Reads the data of one logical sector.

Function	Description
<code>FS_STORAGE_ReadSectorEx()</code>	Reads the contents of one logical sector from the storage device.
<code>FS_STORAGE_ReadSectors()</code>	Reads the data of one or more logical sectors.
<code>FS_STORAGE_ReadSectorsEx()</code>	Reads the contents of multiple logical sectors from a storage device.
<code>FS_STORAGE_RefreshSectors()</code>	Reads the contents of a logical sector and writes it back.
<code>FS_STORAGE_RefreshSectorsEx()</code>	Reads the contents of a logical sector and writes it back.
<code>FS_STORAGE_ResetCounters()</code>	Sets all statistical counters to 0.
<code>FS_STORAGE_SetAutoMountType()</code>	Sets the automatic mount behavior.
<code>FS_STORAGE_SetAutoMountTypeEx()</code>	Sets the automatic mount behavior.
<code>FS_STORAGE_SetOnDeviceActivityCallback()</code>	Registers a function to be called on any logical sector read or write operation.
<code>FS_STORAGE_Sync()</code>	Writes cached information to storage device.
<code>FS_STORAGE_SyncEx()</code>	Writes cached information to storage device.
<code>FS_STORAGE_SyncSectors()</code>	Synchronizes the contents of one or more logical sectors.
<code>FS_STORAGE_SyncSectorsEx()</code>	Synchronizes the contents of one or more logical sectors.
<code>FS_STORAGE_Unmount()</code>	Synchronizes a volume and marks it as not initialized.
<code>FS_STORAGE_UnmountEx()</code>	Synchronizes the volume and marks it as not initialized.
<code>FS_STORAGE_UnmountForced()</code>	Marks a volume it as not initialized.
<code>FS_STORAGE_UnmountForcedEx()</code>	Marks the volume as not initialized without synchronizing it.
<code>FS_STORAGE_WriteSector()</code>	Modifies the data of a logical sector.
<code>FS_STORAGE_WriteSectorEx()</code>	Writes a logical sector to the storage device.
<code>FS_STORAGE_WriteSectors()</code>	Modifies the data of one or more logical sectors.
<code>FS_STORAGE_WriteSectorsEx()</code>	Writes multiple logical sectors to the storage device.
FAT related functions	
<code>FS_FAT_ConfigDirtyFlagUpdate()</code>	Enables / disables the update of the flag that indicates if the volume has been unmounted correctly.
<code>FS_FAT_ConfigFATCopyMaintenance()</code>	Enables / disables the update of the second allocation table.
<code>FS_FAT_ConfigFSInfoSectorUse()</code>	Enables / disables the usage of information from the FSInfo sector.
<code>FS_FAT_ConfigROFileMovePermission()</code>	Enables / disables the permission to move (and rename) files and directories with the read-only file attribute set.
<code>FS_FAT_DisableLFN()</code>	Disables the support for long file names.

Function	Description
<code>FS_FAT_FormatSD()</code>	Formats the volume according to specification of SD Association.
<code>FS_FAT_GetConfig()</code>	Returns information about how the FAT component is configured to operate.
<code>FS_FAT_GetLFNConverter()</code>	Returns the type of configured file name converter.
<code>FS_FAT_GrowRootDir()</code>	Increases the size of the root directory.
<code>FS_FAT_SetLFNConverter()</code>	Configures how long file names are to be encoded and decoded.
<code>FS_FAT_SupportLFN()</code>	Enables the support for long file names.
EFS related functions	
<code>FS_EFS_ConfigCaseSensitivity()</code>	Configures how the file names are compared.
<code>FS_EFS_ConfigStatusSectorSupport()</code>	Enables or disables the usage of information from the status sector.
<code>FS_EFS_GetConfig()</code>	Returns information about how the EFS component is configured to operate.
<code>FS_EFS_SetFileNameConverter()</code>	Configures how file names are to be encoded.
Error-handling functions	
<code>FS_ClearErr()</code>	Clears error status of a file handle.
<code>FS_ErrorNo2Text()</code>	Returns a human-readable text description of an API error code.
<code>FS_FEOF()</code>	Returns if end of file has been reached.
<code>FS_FError()</code>	Returns error status of a file handle.
Configuration checking functions	
<code>FS_CONF_GetDebugLevel()</code>	Returns the level of debug information configured for the file system.
<code>FS_CONF_GetDirectoryDelimiter()</code>	Returns the character that is configured as delimiter between the directory names in a file path.
<code>FS_CONF_GetMaxPath()</code>	Returns the configured maximum number of characters in a path to a file or directory.
<code>FS_CONF_GetNumVolumes()</code>	Returns the maximum number of volumes configured for the file system.
<code>FS_CONF_GetOSLocking()</code>	Returns the type of task locking configured for the file system.
<code>FS_CONF_IsCacheSupported()</code>	Checks if the file system is configured to support the sector cache.
<code>FS_CONF_IsDeInitSupported()</code>	Checks if the file system is configured to support deinitialization.
<code>FS_CONF_IsEFSSupported()</code>	Checks if the file system is configured to support the EFS file system.
<code>FS_CONF_IsEncryptionSupported()</code>	Checks if the file system is configured to support encryption.
<code>FS_CONF_IsFATSupported()</code>	Checks if the file system is configured to support the FAT file system.

Function	Description
<code>FS_CONF_IsFreeSectorSupported()</code>	Checks if the file system is configured to support the "free sector" command.
<code>FS_CONF_IsJournalSupported()</code>	Checks if the file system is configured to support journaling.
<code>FS_CONF_IsTrialVersion()</code>	Checks if the file system has been configured as a trial (limited) version.
<code>FS_GetVersion()</code>	Returns the version number of the file system.
Obsolete functions	
<code>FS_AddOnExitHandler()</code>	Registers a deinitialization callback.
<code>FS_CloseDir()</code>	Closes a directory.
<code>FS_ConfigOnWriteDirUpdate()</code>	Configures if the directory entry has be updated after writing to file.
<code>FS_DirEnt2Attr()</code>	Loads attributes of a directory entry.
<code>FS_DirEnt2Name()</code>	Loads the name of a directory entry.
<code>FS_DirEnt2Size()</code>	Loads the size of a directory entry.
<code>FS_DirEnt2Time()</code>	Loads the time stamp of a directory entry.
<code>FS_GetNumFiles()</code>	API function.
<code>FS_OpenDir()</code>	API function.
<code>FS_ReadDir()</code>	Reads next directory entry in directory.
<code>FS_RewindDir()</code>	Sets pointer for reading the next directory entry to the first entry in the directory.

4.3 File system control functions

4.3.1 FS_Init()

Description

Starts the file system.

Prototype

```
void FS_Init(void);
```

Additional information

FS_Init() initializes the file system and creates resources required for the access of the storage device in a multi-tasking environment. This function has to be called before any other file system API function.

Example

```
#include "FS.h"

void SampleInit(void) {
    FS_Init();
    //
    // Access file system
    //
}
```

4.3.2 FS_DeInit()

Description

Frees allocated resources.

Prototype

```
void FS_DeInit(void);
```

Additional information

This function is optional. `FS_DeInit()` frees all resources that are allocated by the file system after initialization. Also, all static variables of all file system layers are reset in order to guarantee that the file system remains in a known state after deinitialization. The application can call this function only after it called `FS_Init()`.

This function has to be used when the file system is reset at runtime. For example this is the case if the system uses a software reboot which reinitializes the target application.

This function is available if the emFile sources are compiled with the `FS_SUPPORT_DEINIT` configuration define set to 1.

Example

```
#include "FS.h"

void SampleDeInit(void) {
    FS_Init();
    //
    // Access the file system...
    //
    FS_DeInit();
    //
    // The file system cannot be accessed anymore.
    //
}
```

4.3.3 FS_Mount()

Description

Initializes a volume in default access mode.

Prototype

```
int FS_Mount(const char * sVolumeName);
```

Parameters

Parameter	Description
<code>sVolumeName</code>	The name of a volume. If the empty string is specified, the first device in the volume table is used.

Return value

= 0 Volume is not mounted.
 = FS_MOUNT_RO Volume is mounted read only.
 = FS_MOUNT_RW Volume is mounted read/write.
 < 0 Error code indicating the failure reason. Refer to `FS_ErrorNo2Text()`.

Additional information

The storage device has to be mounted before being accessed for the first time after file system initialization. The file system is configured by default to automatically mount the storage device at the first access in read / write mode. This function can be used to explicitly mount the storage device if the automatic mount behavior has been disabled via `FS_SetAutoMount()`. Refer to `FS_SetAutoMount()` for an overview of the different automatic mount types.

Example

```
#include "FS.h"

void SampleMount(void) {
    FS_Init();
    //
    // Mount default volume in read / write mode.
    //
    FS_Mount("");
    //
    // Access the data stored on the file system.
    //
}
```

4.3.4 FS_MountEx()

Description

Initializes a volume in a specified access mode.

Prototype

```
int FS_MountEx(const char * sVolumeName,
              U8      MountType);
```

Parameters

Parameter	Description
<code>sVolumeName</code>	The name of the volume. If the empty string is specified, the first device in the volume table is used.
<code>MountType</code>	Specifies how the volume has to be mounted. <ul style="list-style-type: none"> • <code>FS_MOUNT_RO</code> Read only access. • <code>FS_MOUNT_RW</code> Read / write access.

Return value

= 0 Volume is not mounted.
= `FS_MOUNT_RO` Volume is mounted read only.
= `FS_MOUNT_RW` Volume is mounted read/write.
< 0 Error code indicating the failure reason. Refer to `FS_ErrorNo2Text()`.

Additional information

Performs the same operation as `FS_Mount()` while it allows the application to specify how the storage device has to be mounted.

Example

```
#include "FS.h"

void SampleMountEx(void) {
    FS_Init();
    //
    // Mount default volume in read-only mode.
    //
    FS_MountEx("", FS_MOUNT_RO);
    //
    // Access the data stored on the file system.
    //
}
```

4.3.5 FS_SetAutoMount()

Description

Sets the automatic mount behavior.

Prototype

```
void FS_SetAutoMount(const char * sVolumeName,
                    U8      MountType);
```

Parameters

Parameter	Description
<code>sVolumeName</code>	Pointer to a string containing the name of the volume. If the empty string is specified, the first device in the volume table is used.
<code>MountType</code>	Specifies how the volume has to be mounted. <ul style="list-style-type: none"> • <code>FS_MOUNT_RO</code> Allows to automatically mount the volume in read only mode. • <code>FS_MOUNT_RW</code> Allows to automatically mount the volume in read / write mode. • <code>0</code> Disables the automatic mount operation for the volume.

Additional information

By default, the file system is configured to automatically mount all volumes in read / write mode and this function can be used to change the default automatic mount type or to disable the automatic mounting.

Example

```
#include "FS.h"

void SampleSetAutoMount(void) {
    FS_SetAutoMount("", FS_MOUNT_R);    // Mount default volume in read-only mode.
}
```

4.3.6 FS_Sync()

Description

Saves cached information to storage.

Prototype

```
int FS_Sync(const char * sVolumeName);
```

Parameters

Parameter	Description
<code>sVolumeName</code>	Pointer to a string containing the name of the volume to be synchronized. If the empty string is specified, the first configured volume is used.

Return value

= 0 OK, volume synchronized
 ≠ 0 Error code indicating the failure reason. Refer to `FS_ErrorNo2Text()` for more information.

Additional information

The function write the contents of write buffers and updates the management information of all opened file handles to storage device. All the file handles are left open. If configured, `FS_Sync()` also writes to storage the changes present in the write cache and in the journal. `FS_Sync()` can be called from the same task as the one writing data or from a different task.

Example

```
#include "FS.h"

void SampleSync(void) {
    FS_Sync(""); // Synchronize the default volume.
}
```

4.3.7 FS_Unmount()

Description

Synchronizes the data and marks the volume as not initialized.

Prototype

```
void FS_Unmount(const char * sVolumeName);
```

Parameters

Parameter	Description
<code>sVolumeName</code>	Pointer to a string containing the name of the volume to be unmounted. If the empty string is specified, the first device in the volume table is used. Can not be <code>NULL</code> .

Additional information

This function closes all open files and synchronizes the volume, that is writes all cached data to storage device. `FS_Unmount()` has to be called before a storage device is removed to make sure that all the information cached by the file system is updated to storage device. This function is also useful when shutting down a system.

The volume is initialized again at the next call to any other file system API function that requires access to storage device. The application can also explicitly initialize the volume via `FS_Mount()` or `FS_MountEx()`.

Example

```
#include "FS.h"

void SampleUnmount(void) {
    FS_Unmount(""); // Unmount the default volume.
}
```

4.3.8 FS_UnmountForced()

Description

Marks the volume as not initialized.

Prototype

```
void FS_UnmountForced(const char * sVolumeName);
```

Parameters

Parameter	Description
<code>sVolumeName</code>	Pointer to a string containing the name of the volume to be unmounted. If the empty string is specified, the first device in the volume table is used.

Additional information

This function performs the same operations as `FS_Unmount()`. `FS_UnmountForced()` has to be called if a storage device has been removed before it could be regularly unmounted. When using `FS_UnmountForced()` there is no guarantee that the information cached by the file system is updated to storage.

The volume is initialized again at the next call to any other file system API function that requires access to storage device. The application can also explicitly initialize the volume via `FS_Mount()` or `FS_MountEx()`.

Opened file handles are only marked as invalid but they are not closed. The application has to close them explicitly by calling `FS_FClose()`.

Example

```
#include "FS.h"
#include "FS_OS.h"

void SampleUnmountForced(void) {
    int IsPresentNew;
    int IsPresent;

    IsPresent = FS_GetVolumeStatus("");
    while (1) {
        IsPresentNew = FS_GetVolumeStatus("");
        //
        // Check if the presence status of the storage device has been changed.
        //
        if (IsPresentNew != IsPresent) {
            if (IsPresentNew == FS_MEDIA_IS_PRESENT) {
                FS_Mount("");
            } else {
                FS_UnmountForced("");
            }
            IsPresent = IsPresentNew;
        }
        FS_X_OS_Delay(500);
    }
}
```

4.3.9 Volume mounting modes

Description

Modes for mounting a volume.

Definition

```
#define FS_MOUNT_RO    FS_MOUNT_R
#define FS_MOUNT_RW   (FS_MOUNT_R | FS_MOUNT_W)
```

Symbols

Definition	Description
FS_MOUNT_RO	Read-only. Data can only be read from storage device.
FS_MOUNT_RW	Read / Write. Data can be read from and written to storage device.

4.4 File system configuration functions

The file system control functions listed in this section can only be used in the runtime configuration phase. This means in practice that they can only be called from within `FS_X_AddDevices()`.

4.4.1 FS_AddDevice()

Description

Adds a driver to file system.

Prototype

```
FS_VOLUME *FS_AddDevice(const FS_DEVICE_TYPE * pDevType);
```

Parameters

Parameter	Description
<code>pDevType</code>	in Pointer to a function table identifying the driver that has to be added.

Return value

≠ 0 OK, driver added.
= 0 An error occurred.

Additional information

This function can be used to add a device or a logical driver to file system. The application has to add at least one driver to file system.

The function performs the following operations:

- Adds a physical device. This initializes the driver, allowing the driver to identify the storage device if required and to allocate memory for driver level management of the storage device. This makes sector operations possible.
- Assigns a logical volume to physical device. This makes it possible to mount the storage device, making it accessible for the file system and allowing file operations to be performed on it.

Example

```
#include "FS.h"

void FS_X_AddDevices(void) {
    //
    // Basic configuration of the file system...
    //

    //
    // Add and configure a device driver for NAND flash.
    //
    FS_AddDevice(&FS_NAND_UNI_Driver);

    //
    // Additional configuration of the file system...
    //
}
```

4.4.2 FS_AddPhysDevice()

Description

Adds a device to file system without assigning a volume to it.

Prototype

```
int FS_AddPhysDevice(const FS_DEVICE_TYPE * pDevType);
```

Parameters

Parameter	Description
<code>pDevType</code>	in Pointer to a function table identifying the driver that has to be added.

Return value

= 0 OK, storage device added.
≠ 0 An error occurred.

Additional information

This function can be used to add a device or a logical driver to file system. It works similarly to `FS_AddDevice()` with the difference that it does not assign a logical volume to storage device. This means that the storage device is not directly accessible by the application via the API functions of the file system. An additional logical driver is required to be added via `FS_AddDevice()` to make the storage device visible to application.

`FS_AddPhysDevice()` initializes the driver, allowing the driver to identify the storage device as far as required and allocate memory required for driver level management of the device. This makes sector operations possible.

4.4.3 FS_AssignMemory()

Description

Assigns a memory pool to the file system.

Prototype

```
void FS_AssignMemory(U32 * pData,
                    U32  NumBytes);
```

Parameters

Parameter	Description
<code>pData</code>	in A pointer to the start of the memory region assigned to file system.
<code>NumBytes</code>	Size of the memory pool assigned.

Additional information

emFile comes with a simple semi-dynamic internal memory manager that is used to satisfy the runtime memory requirements of the file system. `FS_AssignMemory()` can be used to provide a memory pool to the internal memory manager of the file system. If not enough memory is assigned, the file system calls `FS_X_Panic()` in debug builds which by default halts the execution of the application. The actual number of bytes allocated is stored in the global variable `FS_Global.MemManager.NumBytesAllocated`. This variable can be used to fine-tune the size of the memory pool.

emFile supports also the use of an external memory manager (e.g. via `malloc()` and `free()` functions of the standard C library). The selection between the internal and the external memory management has to be done at compile time via the `FS_SUPPORT_EXT_MEM_MANAGER` define. The configuration of the memory management functions is done via `FS_SetMemHandler()`.

This function has to be called in the initialization phase of the file system; typically in `FS_X_AddDevices()`. The support for internal memory management has to be enabled at compile time by setting the `FS_SUPPORT_EXT_MEM_MANAGER` define to 0. `FS_AssignMemory()` does nothing if the `FS_SUPPORT_EXT_MEM_MANAGER` define is set to 1.

Example

```
#include "FS.h"

#define ALLOC_SIZE    0x1000

static U32 _aMemBlock[ALLOC_SIZE / 4];

void FS_X_AddDevices(void) {
    FS_AssignMemory(_aMemBlock, sizeof(_aMemBlock));
    //
    // Perform additional file system configuration.
    //
}
```

4.4.4 FS_ConfigFileBufferDefault()

Description

Configures the size and flags for the file buffer.

Prototype

```
int FS_ConfigFileBufferDefault(int BufferSize,
                              int Flags);
```

Parameters

Parameter	Description
<code>BufferSize</code>	Size of the file buffer in bytes.
<code>Flags</code>	File buffer operating mode. <ul style="list-style-type: none"> • 0 Read file buffer. • <code>FS_FILE_BUFFER_WRITE</code> Read / write file buffer. • <code>FS_FILE_BUFFER_ALIGNED</code> Logical sector boundary alignment.

Return value

= 0 OK, the file buffer has been configured.
 ≠ 0 Error code indicating the failure reason.

Additional information

The function has to be called only once, in `FS_X_AddDevices()`. If called after `FS_Init()` the function does nothing and generates a warning.

The file system allocates a file buffer of `BufferSize` bytes for each file the application opens. The operating mode of the file buffer can be changed at runtime via `FS_SetFileBufferFlags()`. If file buffers of different sizes are required `FS_SetFileBuffer()` should be used instead.

For best performance it is recommended to set the size of the file buffer to be equal to the size of the logical sector. Smaller file buffer sizes can also be used to reduce the RAM usage.

`FS_SetFileBuffer()` is available if the emFile sources are compiled with the `FS_SUPPORT_FILE_BUFFER` configuration define set to 1.

Example

```
#include "FS.h"

#define ALLOC_SIZE    0x1000

static U32 _aMemBlock[ALLOC_SIZE / 4];

void FS_X_AddDevices(void) {
    FS_AssignMemory(_aMemBlock, sizeof(_aMemBlock));
    //
    // Set the file buffer of 512 bytes for read and write operations.
    // The file buffer is allocated at runtime for each opened file
    // from _aMemBlock.
    //
    #if (FS_USE_FILE_BUFFER || FS_SUPPORT_FILE_BUFFER)
        FS_ConfigFileBufferDefault(512, FS_FILE_BUFFER_WRITE);
    #endif
}
```

4.4.5 FS_LOGVOL_Create()

Description

Creates a driver instance.

Prototype

```
int FS_LOGVOL_Create(const char * sVolumeName);
```

Parameters

Parameter	Description
<code>sVolumeName</code>	Name of the volume to create.

Return value

= 0 OK, volume has been created.
 ≠ 0 An error occurred.

Additional information

This function creates an instance of a logical volume. A logical volume is the representation of one or more physical devices as a single device. It allows treating multiple physical devices as one larger device. The file system takes care of selecting the correct location on the correct physical device when reading from or writing to the logical volume. Logical volumes are typically used if multiple flash devices (NOR or NAND) are present, but they should be presented to the application in the same way as a single device with the combined capacity of both.

`sVolumeName` is the name that has to be assigned to the logical volume. This is the volume name that is passed to some of the FS API functions and that has to be used in a file path.

`FS_LOGVOL_Create()` does nothing if the module is configured to work in driver mode by setting the `FS_LOGVOL_SUPPORT_DRIVER_MODE` define option to 1. In this case a logical driver is created by adding it via `FS_AddDevice()` to file system.

Normally, all devices are added individually using `FS_AddDevice()`. This function adds the devices physically as well as logically to the file system. In contrast to adding all devices individually, all devices can be combined in a logical volume with a total size of all combined devices. To create a logical volume the following steps have to be performed: 1. The storage device has to be physically added to the file system using `FS_AddPhysDevice()`. 2. A logical volume has to be created using `FS_LOGVOL_Create()`. 3. The devices which are physically added to the file system have to be added to the logical volume using `FS_LOGVOL_AddDevice()`.

4.4.6 FS_LOGVOL_AddDevice()

Description

Adds a storage device to a logical volume.

Prototype

```
int FS_LOGVOL_AddDevice(const char          * sVolumeName,
                       const FS_DEVICE_TYPE * pDeviceType,
                       U8                    DeviceUnit,
                       U32                   StartSector,
                       U32                   NumSectors);
```

Parameters

Parameter	Description
<code>sVolumeName</code>	Name of the logical volume.
<code>pDeviceType</code>	Type of the storage device that has to be added.
<code>DeviceUnit</code>	Index of the storage device that has to be added (0-based).
<code>StartSector</code>	Index of the first sector that has to be used as storage (0-based).
<code>NumSectors</code>	Number of sectors that have to be used as storage.

Return value

= 0 OK, storage device added.
 ≠ 0 An error occurred.

Additional information

Only devices with an identical sector size can be combined to a logical volume. All additionally added devices need to have the same sector size as the first physical device of the logical volume.

This function does nothing if `FS_LOGVOL_SUPPORT_DRIVER_MODE` is set to 1.

4.4.7 FS_SetFileBufferFlags()

Description

Changes the operating mode of the file buffer.

Prototype

```
int FS_SetFileBufferFlags(FS_FILE * pFile,
                          int      Flags);
```

Parameters

Parameter	Description
<code>pFile</code>	Handle to opened file.
<code>Flags</code>	File buffer operating mode. <ul style="list-style-type: none"> • 0 Read file buffer. • <code>FS_FILE_BUFFER_WRITE</code> Read / write file buffer. • <code>FS_FILE_BUFFER_ALIGNED</code> Logical sector boundary alignment.

Return value

= 0 OK, file buffer flags changed.
 ≠ 0 Error code indicating the failure reason.

Additional information

This function can only be called immediately after `FS_FOpen()`, to change the operating mode of the file buffer (read or read / write).

`FS_SetFileBufferFlags()` is available if the emFile sources are compiled with the `FS_SUPPORT_FILE_BUFFER` configuration define set to 1.

Example

```
#include "FS.h"

void SampleSetFileBufferFlags(void) {
    FS_FILE * pFile;
    U8      abData[16];

    pFile = FS_FOpen("Test.txt", "w");
    if (pFile != NULL) {
        memset(abData, 'a', sizeof(abData));
        FS_SetFileBufferFlags(pFile, FS_FILE_BUFFER_WRITE);
        FS_Write(pFile, abData, sizeof(abData));
        FS_FClose(pFile);
    }
}
```

4.4.8 FS_SetFileBufferFlagsEx()

Description

Changes the operating mode of the file buffer.

Prototype

```
int FS_SetFileBufferFlagsEx(const char * sVolumeName,
                           int      Flags);
```

Parameters

Parameter	Description
<code>sVolumeName</code>	Name of the volume for which to set the flags.
<code>Flags</code>	File buffer operating mode. <ul style="list-style-type: none"> • 0 Read file buffer. • <code>FS_FILE_BUFFER_WRITE</code> Read / write file buffer. • <code>FS_FILE_BUFFER_ALIGNED</code> Logical sector boundary alignment.

Return value

= 0 OK, operating mode changed.
 ≠ 0 Error code indicating the failure reason.

Additional information

This function can be used to change the operating mode of the file buffer for the files that are located on a specific volume.

`FS_SetFileBufferFlagsEx()` is available if the emFile sources are compiled with the `FS_SUPPORT_FILE_BUFFER` configuration define set to 1.

4.4.9 FS_SetFileWriteMode()

Description

Configures the file write mode.

Prototype

```
void FS_SetFileWriteMode(FS_WRITEMODE WriteMode);
```

Parameters

Parameter	Description
WriteMode	Specifies how to write to file: <ul style="list-style-type: none"> • FS_WRITEMODE_SAFE Updates the allocation table and the directory entry at each write to file operation. • FS_WRITEMODE_MEDIUM Updates the allocation table at each write to file operation. • FS_WRITEMODE_FAST The allocation table and directory entry are updated when the file is closed.

Additional information

This function can be called to configure which mode the file system has to use when writing to a file. The file system uses by default FS_WRITEMODE_SAFE which allows the maximum fail-safe behavior, since the allocation table and the directory entry is updated on every write operation to file.

If FS_WRITEMODE_FAST is set, the update of the allocation table is performed using a special algorithm. When writing to the file for the first time, the file system checks how many clusters in series are empty starting with the first one occupied by the file. This cluster chain is remembered, so that if the file grows and needs an additional cluster, the allocation doesn't have to be read again in order to find the next free cluster. The allocation table is only modified if necessary, which is the case when:

- All clusters of the cached free-cluster-chain are occupied.
- The volume or the file is synchronized that is when FS_Sync(), FS_FClose(), or FS_SyncFile() is called.
- A different file is written.

Especially when writing large amounts of data, FS_WRITEMODE_FAST allows maximum performance, since usually the file system has to search for a free cluster in the allocation table and link it with the last one occupied by the file. In worst case, multiple sectors of the allocation table have to be read in order to find a free cluster.

Example

```
#include "FS.h"

void FS_X_AddDevices(void) {
    //
    // Configure the file system to write as fast as possible
    // to all files on all volumes.
    //
    FS_SetFileWriteMode(FS_WRITEMODE_FAST);
    //
    // Perform other file system configuration...
    //
}
```

4.4.10 FS_SetFileWriteModeEx()

Description

Configures the write mode of a specified volume.

Prototype

```
int FS_SetFileWriteModeEx(      FS_WRITEMODE  WriteMode,
                              const char    * sVolumeName);
```

Parameters

Parameter	Description
<code>WriteMode</code>	Specifies how to write to file: <ul style="list-style-type: none"> • <code>FS_WRITEMODE_SAFE</code> Updates the allocation table and the directory entry at each write to file operation. • <code>FS_WRITEMODE_MEDIUM</code> Updates the allocation table at each write to file operation. • <code>FS_WRITEMODE_FAST</code> The allocation table and directory entry are updated when the file is closed.
<code>sVolumeName</code>	Identifies the volume for which the write mode has to be changed.

Return value

= 0 OK, write mode set.
 ≠ 0 Error code indicating the failure reason.

Additional information

When not explicitly set using this function the write mode of a volume is the write mode set via `FS_SetFileWriteMode()` or the default write mode (`FS_WRITEMODE_SAFE`). `FS_SetFileWriteModeEx()` is typically on file system configurations using multiple volumes that require different write modes. For example on a file system configured to use two volumes where one volume has to be configured for maximum write performance (`FS_WRITEMODE_FAST`) while on the other volume the write operation has to be fail-safe (`FS_WRITEMODE_SAFE`).

Refer to `FS_SetFileWriteMode()` for detailed information about the different write modes.

Example

```
#include "FS.h"

void FS_X_AddDevices(void) {
    //
    // Configure the file system to write as fast as possible
    // to all files on the "nand:0:" volume.
    //
    FS_SetFileWriteModeEx(FS_WRITEMODE_FAST, "nand:0");
    //
    // Perform other file system configuration...
    //
}
```

4.4.11 FS_SetMemHandler()

Description

Configures functions for memory management.

Prototype

```
void FS_SetMemHandler(FS_MEM_ALLOC_CALLBACK * pFAlloc,
                     FS_MEM_FREE_CALLBACK * pFFree);
```

Parameters

Parameter	Description
<code>pFAlloc</code>	Pointer to a function that allocates memory (e.g. <code>malloc()</code>). It cannot be <code>NULL</code> .
<code>pFFree</code>	Pointer to a function that frees memory (e.g. <code>free()</code>). It cannot be <code>NULL</code> .

Additional information

The application can use this function to configure functions for the memory management. The file system calls `pFAlloc` to allocate memory and `pFFree` to release the allocated memory.

This function has to be called in the initialization phase of the file system; typically in `FS_X_AddDevices()`. The support for external memory management has to be enabled at compile time by setting the `FS_SUPPORT_EXT_MEM_MANAGER` define to 1. `FS_SetMemHandler()` does nothing if `FS_SUPPORT_EXT_MEM_MANAGER` is set to 0 (default).

Example

```
#include <stdlib.h>
#include "FS.h"

void FS_X_AddDevices(void) {
    #if FS_SUPPORT_EXT_MEM_MANAGER
        //
        // Configure functions for dynamic memory allocation.
        //
        FS_SetMemHandler((FS_MEM_ALLOC_CALLBACK *)malloc, free);
    #endif // FS_SUPPORT_EXT_MEM_MANAGER
        //
        // Configure the file system...
        //
    }
}
```

4.4.12 FS_SetMaxSectorSize()

Description

Configures the maximum size of a logical sector.

Prototype

```
int FS_SetMaxSectorSize(unsigned MaxSectorSize);
```

Parameters

Parameter	Description
MaxSectorSize	Number of bytes in the logical sector.

Return value

= 0 OK, the sector size had been set.
≠ 0 Error code indicating the failure reason.

Additional information

The file system uses internal RAM buffers to store the data of logical sectors it accesses. The storage devices added to file system can have different logical sector sizes. Since the size of the logical sectors is not known at the time the internal RAM buffers are allocated the application has to call `FS_SetMaxSectorSize()` to specify the size of the largest logical sector used by the configured drivers.

The default value for the maximum size of a logical sector is 512 bytes. The size of the logical sector supported by a driver can be found in the section that describes the specific driver.

`FS_SetMaxSectorSize()` can be called only at file system initialization in `FS_X_AddDevices()`.

Example

```
#include "FS.h"

void FS_X_AddDevices(void) {
    //
    // This function call is typically required when
    // a NAND flash with 2048 byte pages is used as
    // storage device.
    //
    FS_SetMaxSectorSize(2048);
}
```

4.4.13 FS_MEM_ALLOC_CALLBACK

Description

Type of function called by the file system to allocate memory dynamically.

Type definition

```
typedef void * FS_MEM_ALLOC_CALLBACK(U32 NumBytes);
```

Parameters

Parameter	Description
<code>NumBytes</code>	Number of bytes to be allocated.

Return value

`≠ NULL` OK, pointer to the allocated memory block.
`= NULL` Error, could not allocate memory.

Additional information

The callback function has the same signature as the `malloc()` standard C function. The application can register the callback function via `FS_SetMemHandler()`.

4.4.14 FS_MEM_FREE_CALLBACK

Description

Type of function called by the file system to release dynamically allocated memory.

Type definition

```
typedef void FS_MEM_FREE_CALLBACK(void * pData);
```

Parameters

Parameter	Description
<code>pData</code>	Memory block to be released.

Additional information

The callback function has the same signature as the `free()` standard C function. The application can register the callback function via `FS_SetMemHandler()`. `pMem` points to a memory block that was allocated using a call to `pfAlloc` callback function registered via `FS_SetMemHandler()`.

4.4.15 FS_WRITEMODE

Description

Modes of writing to file.

Type definition

```
typedef enum {
    FS_WRITEMODE_SAFE,
    FS_WRITEMODE_MEDIUM,
    FS_WRITEMODE_FAST,
    FS_WRITEMODE_UNKNOWN
} FS_WRITEMODE;
```

Enumeration constants

Constant	Description
<code>FS_WRITEMODE_SAFE</code>	Allows maximum fail-safe behavior. The allocation table and the directory entry are updated after each write access to file. This write mode provides the slowest performance.
<code>FS_WRITEMODE_MEDIUM</code>	Medium fail-safe. The allocation table is updated after each write access to file. The directory entry is updated only if file is synchronized that is when <code>FS_Sync()</code> , <code>FS_FClose()</code> , or <code>FS_SyncFile()</code> is called.
<code>FS_WRITEMODE_FAST</code>	This write mode provided the maximum performance. The directory entry is updated only if the file is synchronized that is when <code>FS_Sync()</code> , <code>FS_FClose()</code> , or <code>FS_SyncFile()</code> is called. The allocation table is modified only if necessary.
<code>FS_WRITEMODE_UNKNOWN</code>	End of enumeration (for internal use only)

4.5 File access functions

The functions in this section can be used to access the data stored in a file.

4.5.1 FS_FClose()

Description

Closes an opened file.

Prototype

```
int FS_FClose(FS_FILE * pFile);
```

Parameters

Parameter	Description
<code>pFile</code>	Handle to the file to be closed.

Return value

- = 0 OK, file handle has been successfully closed.
- ≠ 0 Error code indicating the failure reason. Refer to `FS_ErrorNo2Text()`.

Example

```
#include "FS.h"

void SampleFClose(void) {
    FS_FILE * pFile;

    pFile = FS_FOpen("Test.txt", "r");
    if (pFile) {
        //
        // Access file.
        //
        FS_FClose(pFile);
    }
}
```

4.5.2 FS_FGets()

Description

Reads a line of text from file.

Prototype

```
char *FS_FGets(char * sData,
               int   SizeOfData,
               FS_FILE * pFile);
```

Parameters

Parameter	Description
<code>sData</code>	out Buffer that receives the data read from file. It cannot be NULL.
<code>SizeOfData</code>	Number of bytes in <code>sData</code> . It cannot be 0.
<code>pFile</code>	Handle to opened file. It cannot be NULL.

Return value

≠ NULL OK, data read successfully. The returned value is `sData` buffer.
 = NULL An error occurred.

Additional information

This function starts reading from the current position in the file and advances the current file position by the number of bytes read.

`FS_FGets()` returns when either a line terminator is read from file and stored to `sData`, `SizeOfData` - 1 bytes are stored to `sData` or the end of file is reached. The data stored to `sData` is 0-terminated.

A line terminator can be either a single Line Feed character (0x0A), a single Carriage Return character (0x0D) or a Carriage Return and Line Feed character sequence (0x0D 0x0A).

The file to read from has to be opened with read permissions. For more information about open modes refer to `FS_FOpen()`.

The application can check for the actual error using `FS_FError()`.

Example

```
#include "FS.h"

void SampleFGets(void) {
    FS_FILE * pFile;
    char      ac[128];
    char      * s;

    pFile = FS_FOpen("Test.txt", "r");
    if (pFile != NULL) {
        for (;;) {
            s = FS_FGets(ac, sizeof(ac), pFile);
            if (s == NULL) {
                break;
            }
        }
        FS_FClose(pFile);
    }
}
```

4.5.3 FS_FOpen()

Description

Opens an existing file or creates a new one.

Prototype

```
FS_FILE *FS_FOpen(const char * sFileName,
                  const char * sMode);
```

Parameters

Parameter	Description
<code>sFileName</code>	Name of the file to be opened or created. It is a 0-terminated string that cannot be <code>NULL</code> .
<code>sMode</code>	Indicates how the file should be opened. It is a 0-terminated string that cannot be <code>NULL</code> .

Return value

≠ 0 OK, pointer to a file handle that identifies the opened file.
 = 0 Error, unable to open the file.

Additional information

The `sMode` parameter can take one of the following values:

<code>sMode</code>	Description
"r" or "rb"	Opens file for reading.
"w" or "wb"	Truncates to zero length or creates file for writing.
"a" or "ab"	Opens or creates file for writing at end of file.
"r+", "r+b" or "rb+"	Opens file for reading and writing.
"w+", "w+b" or "wb+"	Truncates file to zero length or creates file for reading and writing.
"a+", "a+b" or "ab+"	Opens or creates file for reading and writing at end of file.

For more details about `FS_FOpen()`, refer to the ANSI C documentation of the `fopen()` function.

The file system does not distinguish between binary and text mode; the files are always accessed in binary mode.

In order to use long file names with FAT, the `FS_FAT_SupportLFN()` has to be called before after the file system is initialized.

`FS_FOpen()` accepts file names encoded in UTF-8 format. This feature is disabled by default. To enable it the file system has to be compiled with the `FS_FAT_SUPPORT_UTF8` configuration define to 1. Additionally, the support for long file names has to be enabled for volumes formatted as FAT.

Example

```
#include "FS.h"

void SampleOpenFile(void) {
    FS_FILE * pFile;

    //
    // Opens for reading a file on the default volume.
    //
    pFile = FS_FOpen("Test.txt", "r");
    //
}
```

```
// Opens for writing a file on the default volume.
//
pFile = FS_FOpen("Test.txt", "w");
//
// Opens for reading a file in folder "SubDir" on the default volume.
// The directory delimiter is the '\' character.
//
pFile = FS_FOpen("\\SubDir\\Test.txt", "r");
//
// Opens for reading a file on the first RAM disk volume.
//
pFile = FS_FOpen("ram:Test.txt", "r");
//
// Opens for reading a file on the second RAM disk volume.
//
pFile = FS_FOpen("ram:1:Test.txt", "r");
//
// Opens for writing a file with a long name for writing.
//
FS_FAT_SupportLFN();
pFile = FS_FOpen("Long file name.text", "w");
//
// Opens for writing a file with a name encoded in UTF-8 format.
// The file system has to be compiled with FS_FAT_SUPPORT_UTF8 define
// set to 1. The name contains the following characters:
//   small a, umlaut mark
//   small o, umlaut mark
//   small sharp s
//   small u, umlaut mark
//   '.'
//   't'
//   'x'
//   't'
//
FS_FAT_SupportLFN();
pFile = FS_FOpen("\\xC3\xA4\xC3\xB6\xC3\x9F\xC3\xBC.txt", "w");
}
```

4.5.4 FS_FOpenEx()

Description

Opens an existing file or creates a new one.

Prototype

```
int FS_FOpenEx(const char    * sFileName,
               const char    * sMode,
               FS_FILE ** ppFile);
```

Parameters

Parameter	Description
<code>sFileName</code>	Name of the file to be opened or created. It is a 0-terminated string that cannot be <code>NULL</code> .
<code>sMode</code>	Indicates how the file should be opened. It is a 0-terminated string that cannot be <code>NULL</code> .
<code>ppFile</code>	Pointer to a file handle pointer that receives the opened file handle.

Return value

= 0 OK, file opened.
 ≠ 0 Error code indicating the failure reason.

Additional information

For additional information about the `sMode` parameter refer to `FS_FOpen()`.

Example

```
#include <stdio.h>
#include "FS.h"

FS_FILE * pFile;

/*****
 *
 *      SampleFOpenEx
 *
 *      Function description
 *      Opens for reading a file on the default volume.
 */
void SampleFOpenEx(void) {
    int r;
    char ac[100];

    r = FS_FOpenEx("Test.txt", "r", &pFile);
    if (r) {
        SEGGER_sprintf(ac, sizeof(ac), "Could not open file (Reason: %s)\n",
            FS_ErrorNo2Text(r));
        FS_X_Log(ac);
    }
}
```

4.5.5 FS_FPrintf()

Description

Writes a formatted string to a file.

Prototype

```
int FS_FPrintf(      FS_FILE * pFile,
                   const char * sFormat,
                   ...);
```

Parameters

Parameter	Description
<code>pFile</code>	Opened file handle. It cannot be <code>NULL</code> .
<code>sFormat</code>	Format of the data to be written (0-terminated string). It cannot be <code>NULL</code> .

Return value

- ≥ 0 OK, number of bytes written to file.
- < 0 Error code indicating the failure reason.

Additional information

This function works in the same way as the `fprintf()` standard C library function. It formats the data according to `sFormat` and then writes the formatted string to `pFile`. The format specification is identical to that of `fprintf()`. `FS_FPrintf()` relies on `SEGGER_vsnprintfEx()` to perform the actual formatting.

The file position is advanced by the number of bytes written.

`FS_FPrintf()` uses a buffer allocated on the stack for the formatting of the data. The size of this buffer can be configured via `FS_BUFFER_SIZE_FILE_PRINT` and it has to be at least 1 byte large.

Example

```
#include "FS.h"

void SampleFPrintf(void) {
    FS_FILE * pFile;
    int      i;

    pFile = FS_FOpen("Test.txt", "w");
    if (pFile != NULL) {
        for (i = 0; i < 10; ++i) {
            FS_FPrintf(pFile, "Counter value: %d\n", i);
        }
        FS_FClose(pFile);
    }
}
```

4.5.6 FS_Fputs()

Description

Writes a 0-terminated string to a file.

Prototype

```
int FS_Fputs(const char * sData,
            FS_FILE * pFile);
```

Parameters

Parameter	Description
<code>sData</code>	Data to be written (0-terminated string). It cannot be <code>NULL</code> .
<code>pFile</code>	Opened file handle. It cannot be <code>NULL</code> .

Return value

= 0 OK, data written successfully.
 ≠ 0 Error code indicating the failure reason.

Additional information

This function works in the same way as the `fputs()` standard C library function. It writes the 0-terminated string `sData` to the file `pFile`. The 0-terminator is not written to file. The file position is advanced by the number of bytes written.

Example

```
#include "FS.h"

const char acText[] = "Hello world\n";

void SampleFputs(void) {
    FS_FILE * pFile;

    pFile = FS_FOpen("Test.txt", "w");
    if (pFile != NULL) {
        FS_Fputs(acText, pFile);
        FS_FClose(pFile);
    }
}
```

4.5.7 FS_FRead()

Description

Reads data from file.

Prototype

```
U32 FS_FRead(void * pData,
              U32  ItemSize,
              U32  NumItems,
              FS_FILE * pFile);
```

Parameters

Parameter	Description
<code>pData</code>	Buffer that receives the data read from file.
<code>ItemSize</code>	Size of one item to be read from file (in bytes).
<code>NumItems</code>	Number of items to be read from the file.
<code>pFile</code>	Handle to opened file. It cannot be NULL.

Return value

Number of items read.

Additional information

The file has to be opened with read permissions. For more information about open modes refer to `FS_FOpen()`.

The application has to check for possible errors using `FS_FError()` if the number of items actually read is different than the number of items requested to be read by the application.

The data is read from the current position in the file that is indicated by the file pointer. `FS_FRead()` moves the file pointer forward by the number of bytes successfully read.

Example

```
#include "FS.h"

char acBuffer[100];

void SampleFRead(void) {
    FS_FILE * pFile;
    U32      NumItems;
    int      ErrCode;

    pFile = FS_FOpen("Test.txt", "r");
    if (pFile) {
        NumItems = FS_FRead(acBuffer, 1, sizeof(acBuffer), pFile);
        if (NumItems != sizeof(acBuffer)) {
            ErrCode = FS_FError(pFile);
            if (ErrCode) {
                //
                // An error occurred during the read operation.
                //
            }
        }
        FS_FClose(pFile);
    }
}
```

4.5.8 FS_FSeek()

Description

Sets the current position in file.

Prototype

```
int FS_FSeek(FS_FILE      * pFile,
             FS_FILE_OFF  Offset,
             int           Origin);
```

Parameters

Parameter	Description
<code>pFile</code>	Handle to opened file.
<code>Offset</code>	Byte offset for setting the file pointer position.
<code>Origin</code>	Indicates how the file pointer has to be moved.

Return value

= 0 OK, file pointer has been positioned according to the specified parameters.

≠ 0 Error code indicating the failure reason.

Additional information

`FS_FSeek()` moves the file pointer to a new location by a number of bytes relative to the position specified by the `Origin` parameter. The `Origin` parameter can take the values specified by *File positioning reference* on page 121.

The file pointer can be repositioned anywhere in the file. It is also possible to reposition the file pointer beyond the end of the file. This feature is used together with `FS_SetEndOfFile()` to reserve space for a file (preallocate the file).

Alternative name

`FS_SetFilePos`

Example

```
#include "FS.h"

const char acText[]="Some text will be overwritten";

void SampleFTell(void) {
    FS_FILE * pFile;

    pFile = FS_FOpen("Test.txt", "w");
    if (pFile) {
        //
        // Write the data to file.
        //
        FS_FWrite(acText, 1, strlen(acText), pFile);
        //
        // Move the file pointer back 4 bytes from the current
        // position in file. The data stored in the file looks
        // like this: "Some text will be overwritten"
        //
        FS_FSeek(pFile, -4, FS_SEEK_CUR);
        //
        // The write operation overwrites the last
        // 4 characters that is "tten" of the data
        // written in the previous call to FS_FWrite().
        //
        FS_FWrite(acText, 1, strlen(acText), pFile);
        //
        // The data in the file looks now like this:
```

```
// "Some text will be overwriSome text will be overwritten"  
//  
FS_FClose(pFile);  
}  
}
```

4.5.9 FS_FWrite()

Description

Writes data to file.

Prototype

```
U32 FS_FWrite(const void * pData,
              U32      ItemSize,
              U32      NumItems,
              FS_FILE * pFile);
```

Parameters

Parameter	Description
<code>pData</code>	Data to be written to file.
<code>ItemSize</code>	Size of an item to be written to file (in bytes).
<code>NumItems</code>	Number of items to be written to file.
<code>pFile</code>	Handle to opened file. It cannot be <code>NULL</code> .

Return value

Number of elements written.

Additional information

The file has to be opened with write permissions. For more information about open modes refer to `FS_FOpen()`.

The application has to check for possible errors using `FS_FError()` if the number of items actually written is different than the number of items requested to be written by the application.

The data is written at the current position in the file that is indicated by the file pointer. `FS_FWrite()` moves the file pointer forward by the number of bytes successfully written.

Example

```
#include "FS.h"

const char acText[] = "Hello world\n";

void SampleFWrite(void) {
    FS_FILE * pFile;

    pFile = FS_FOpen("Test.txt", "w");
    if (pFile != NULL) {
        FS_FWrite(acText, 1, strlen(acText), pFile);
        FS_FClose(pFile);
    }
}
```

4.5.10 FS_FTell()

Description

Returns current position in file.

Prototype

```
FS_FILE_OFF FS_FTell(FS_FILE * pFile);
```

Parameters

Parameter	Description
<code>pFile</code>	Handle to opened file.

Return value

≠ 0xFFFFFFFF OK, current position of the file pointer.
 = 0xFFFFFFFF An error occurred.

Additional information

The function returns the file position as a signed value for compatibility reasons. The return value has to be treated as a 32-bit unsigned with the value 0xFFFFFFFF indicating an error.

This function simply returns the file pointer member of the file handle structure pointed by `pFile`. Nevertheless, you should not access the `FS_FILE` structure yourself, because that data structure may change in the future.

In conjunction with `FS_FSeek()`, this function can also be used to examine the file size. By setting the file pointer to the end of the file using `FS_SEEK_END`, the length of the file can now be retrieved by calling `FS_FTell()`. Alternatively the `FS_GetFileSize()` function can be used.

Alternative name

`FS_GetFilePos`

Example

```
#include "FS.h"

const char acText[]="Hello world\n";

void SampleFTell(void) {
    FS_FILE * pFile;
    I32      FilePos;

    pFile = FS_FOpen("Test.txt", "w");
    if (pFile) {
        FS_FWrite(acText, 1, strlen(acText), pFile);
        FilePos = FS_FTell(pFile);
        FS_FClose(pFile);
    }
}
```

4.5.11 FS_GetFileSize()

Description

Returns the size of a file.

Prototype

```
U32 FS_GetFileSize(const FS_FILE * pFile);
```

Parameters

Parameter	Description
<code>pFile</code>	Handle to opened file.

Return value

≠ 0xFFFFFFFF File size of the given file in bytes.
= 0xFFFFFFFF An error occurred.

Additional information

The file has to be opened with read or write access.

Example

```
#include "FS.h"

void SampleGetFileSize(void) {
    FS_FILE * pFile;
    U32      FileSize;

    pFile = FS_FOpen("Test.txt", "r");
    if (pFile) {
        FileSize = FS_GetFileSize(pFile);
        FS_FClose(pFile);
    }
}
```

4.5.12 FS_GetFileSizeEx()

Description

Returns the size of a file.

Prototype

```
int FS_GetFileSizeEx(FS_FILE * pFile,
                    U32      * pNumBytes);
```

Parameters

Parameter	Description
<code>pFile</code>	Handle to opened file.
<code>pNumBytes</code>	out Size of the file.

Return value

- = 0 OK, file size returned successfully.
- ≠ 0 Error code indicating the failure reason.

Additional information

This function performs the same operation as `FS_GetFileSize()` with the difference that it returns an error code in case of an error.

The file has to be opened with read or write access.

Example

```
#include "FS.h"

void SampleGetFileSizeEx(void) {
    FS_FILE * pFile;
    U32      FileSize;

    pFile = FS_FOpen("Test.txt", "r");
    if (pFile) {
        FileSize = 0;
        FS_GetFileSizeEx(pFile, &FileSize);
        FS_FClose(pFile);
    }
}
```

4.5.13 FS_Read()

Description

Reads data from a file.

Prototype

```
U32 FS_Read(FS_FILE * pFile,
            void * pData,
            U32 NumBytes);
```

Parameters

Parameter	Description
<code>pFile</code>	Handle to an opened file. It cannot be NULL.
<code>pData</code>	Buffer to receive the read data.
<code>NumBytes</code>	Number of bytes to be read.

Return value

Number of bytes read.

Additional information

The file has to be opened with read permissions. For more information about open modes refer to `FS_FOpen()`.

The application has to check for possible errors using `FS_FError()` if the number of bytes actually read is different than the number of bytes requested to be read by the application.

The data is read from the current position in the file that is indicated by the file pointer. `FS_Read()` moves the file pointer forward by the number of bytes successfully read.

Example

```
#include "FS.h"

U8 abBuffer[100];

void SampleRead(void) {
    FS_FILE * pFile;
    U32 NumBytesRead;

    pFile = FS_FOpen("Test.txt", "r");
    if (pFile) {
        NumBytesRead = FS_Read(pFile, abBuffer, sizeof(abBuffer));
        if (NumBytesRead != sizeof(abBuffer)) {
            //
            // An error occurred.
            //
        }
        FS_FClose(pFile);
    }
}
```

4.5.14 FS_SetEndOfFile()

Description

Sets the file size to current file position.

Prototype

```
int FS_SetEndOfFile(FS_FILE * pFile);
```

Parameters

Parameter	Description
<code>pFile</code>	Handle to opened file.

Return value

= 0 OK, new file size has been set.
 ≠ 0 Error code indicating the failure reason.

Additional information

The file has to be opened with write permissions. Refer to `FS_FOpen()` for more information about the file open modes.

`FS_SetEndOfFile()` can be used to truncate as well as to extend a file. If the file is extended, the contents of the file between the old end-of-file and the new one are not defined. Extending a file (preallocation) can increase the write performance when the application writes large amounts of data to file as the file system is not required anymore to access the allocation table.

Example

```
#include "FS.h"

void SampleSetEndOfFile(void) {
    FS_FILE * pFile;

    //
    // Reserve space for a file of 20000 bytes.
    //
    pFile = FS_FOpen("Test.bin", "r+");
    if (pFile) {
        FS_FSeek(pFile, 20000, FS_SEEK_SET);
        FS_SetEndOfFile(pFile);
        FS_FClose(pFile);
    }
}
```

4.5.15 FS_SetFileSize()

Description

Sets the file size to the specified number of bytes.

Prototype

```
int FS_SetFileSize(FS_FILE * pFile,
                  U32      NumBytes);
```

Parameters

Parameter	Description
<code>pFile</code>	Handle to an opened file.
<code>NumBytes</code>	New file size.

Return value

= 0 OK, new file size has been set.
 ≠ 0 Error code indicating the failure reason.

Additional information

The file has to be opened with write permissions. Refer to `FS_FOpen()` for more information about the file open modes. `FS_SetFileSize()` can be used to extend as well as truncate a file. The file position is preserved if the new file size is larger than or equal to the current file position. Else the file position is set to the end of the file.

Example

```
#include "FS.h"

void SampleSetFileSize(void) {
    FS_FILE * pFile;

    //
    // Create a file 20000 bytes large.
    //
    pFile = FS_FOpen("Test.bin", "r+");
    if (pFile) {
        FS_SetFileSize(pFile, 20000);
        FS_FClose(pFile);
    }
}
```

4.5.16 FS_SyncFile()

Description

Synchronizes file to storage device.

Prototype

```
int FS_SyncFile(FS_FILE * pFile);
```

Parameters

Parameter	Description
<code>pFile</code>	File pointer identifying the opened file. It can be <code>NULL</code> .

Return value

= 0 OK, file(s) synchronized.
 ≠ 0 Error code indicating the failure reason.

Additional information

The function synchronizes all the opened files if a `NULL` is passed as `pFile` parameter.

`FS_SyncFile()` cleans the write buffer if configured and updates the management information to storage device. The function performs basically the same operations as `FS_FClose()` with the only difference that it leaves the file open. `FS_SyncFile()` is used typically with fast or medium file write modes to make sure that the data cached by the file system for the file is written to storage medium.

The function can also be called from a different task than the one that writes to file if the support for multi-tasking is enabled in the file system. The support for multi-tasking can be enabled by compiling the file system sources with the `FS_OS_LOCKING` define is set to value different than 0.

Example

```
#include "FS.h"

void SampleFileSync(void) {
    FS_FILE * pFile;

    FS_SetFileWriteMode(FS_WRITEMODE_FAST);
    pFile = FS_FOpen("Test.txt", "w");
    if (pFile) {
        //
        // Write to file...
        //
        FS_SyncFile(pFile);
        //
        // Write to file...
        //
        FS_SyncFile(pFile);
        //
        // Write to file...
        //
        FS_FClose(pFile);
    }
}
```

4.5.17 FS_Truncate()

Description

Changes the size of a file.

Prototype

```
int FS_Truncate(FS_FILE * pFile,
                U32      NumBytes);
```

Parameters

Parameter	Description
<code>pFile</code>	Handle to an opened file.
<code>NumBytes</code>	The new size of the file.

Return value

= 0 OK, file size successfully modified.
 ≠ 0 Error code indicating the failure reason.

Additional information

The file has to be opened in write mode. For more information about open modes refer to `FS_FOpen()`.

An error is returned if `NumBytes` is larger than the actual file size and the support for POSIX operation is disabled.

If the support for POSIX operation is enabled, then this function can also be used to increase the size of the file. The extra bytes are initialized with 0. The application can enable the support for POSIX operation by building the file system with `FS_SUPPORT_POSIX` set to 1 and by calling at runtime `FS_ConfigPOSIXSupport()` with the `OnOff` parameter set to 1.

`FS_Truncate()` allocates `FS_BUFFER_SIZE_TRUNCATE` bytes on the stack with the support for the POSIX operation enabled.

Example

```
#include "FS.h"

void SampleTruncate(void) {
    FS_FILE * pFile;
    U32      FileSize;
    int      r;

    pFile = FS_FOpen("Test.bin", "r+");
    if (pFile) {
        FileSize = FS_GetFileSize(pFile);
        //
        // Reduce the size of the file by 200 bytes.
        //
        r = FS_Truncate(pFile, FileSize - 200);
        if (r) {
            //
            // An error occurred while truncating file.
            //
        }
    }
    FS_FClose(pFile);
}
```

4.5.18 FS_Verify()

Description

Verifies the file contents.

Prototype

```
int FS_Verify(      FS_FILE * pFile,
                  const void * pData,
                  U32   NumBytes);
```

Parameters

Parameter	Description
<code>pFile</code>	Handle to opened file.
<code>pData</code>	Data to be checked against.
<code>NumBytes</code>	Number of bytes to be checked.

Return value

= 0 Verification was successful.

≠ 0 Verification failed.

Additional information

The function starts checking at the current file position. That is the byte read from file position + 0 is checked against the byte at `pData` + 0, the byte read from file position + 1 is checked against the byte at `pData` + 1 and so on. `FS_Verify()` does not modify the file position.

Example

```
#include "FS.h"

const U8 abVerifyData[4] = { 1, 2, 3, 4 };

void SampleVerify(void) {
    FS_FILE * pFile;
    int      r;

    //
    // Open file and write data into it.
    //
    pFile = FS_FOpen("Test.bin", "w+");
    if (pFile) {
        FS_Write(pFile, abVerifyData, sizeof(abVerifyData));
        //
        // Set file pointer to the start of the data that has to be verified.
        //
        FS_FSeek(pFile, 0, FS_SEEK_SET);
        //
        // Verify data.
        //
        r = FS_Verify(pFile, abVerifyData, sizeof(abVerifyData));
        if (r == 0) {
            FS_X_Log("Verification was successful.\n");
        } else {
            FS_X_Log("Verification failed.\n");
        }
        FS_FClose(pFile);
    }
}
```

4.5.19 FS_Write()

Description

Writes data to file.

Prototype

```
U32 FS_Write(      FS_FILE * pFile,
                  const void * pData,
                  U32   NumBytes);
```

Parameters

Parameter	Description
<code>pFile</code>	Handle to opened file.
<code>pData</code>	The data to be written to file.
<code>NumBytes</code>	Number of bytes to be written to file.

Return value

Number of bytes written.

Additional information

The file has to be opened with write permissions. For more information about open modes refer to `FS_FOpen()`.

The application has to check for possible errors using `FS_FError()` if the number of bytes actually written is different than the number of bytes requested to be written by the application.

The data is written at the current position in the file that is indicated by the file pointer. `FS_FWrite()` moves the file pointer forward by the number of bytes successfully written.

Example

```
#include "FS.h"

void SampleWrite(void) {
    FS_FILE * pFile;
    const char acText[] = "Hello world\n";

    pFile = FS_FOpen("Test.txt", "w");
    if (pFile) {
        FS_Write(pFile, acText, strlen(acText));
        FS_FClose(pFile);
    }
}
```

4.5.20 File positioning reference

Description

Reference point when changing the file position.

Definition

```
#define FS_SEEK_SET    0
#define FS_SEEK_CUR    1
#define FS_SEEK_END    2
```

Symbols

Definition	Description
FS_SEEK_SET	The reference is the beginning of the file.
FS_SEEK_CUR	The reference is the current position of the file pointer.
FS_SEEK_END	The reference is the end-of-file position.

4.6 Operations on files

The functions on this section can be used by an application to manipulate files.

4.6.1 FS_CopyFile()

Description

Copies a file.

Prototype

```
int FS_CopyFile(const char * sFileNameSrc,
               const char * sFileNameDest);
```

Parameters

Parameter	Description
<code>sFileNameSrc</code>	Name of the source file (fully qualified).
<code>sFileNameDest</code>	Name of the destination file (fully qualified).

Return value

= 0 OK, the file has been copied
≠ 0 Error code indicating the failure reason

Additional information

The copy process uses an internal temporary buffer of 512 bytes that is allocated on the stack. The size of this buffer can be configured via `FS_BUFFER_SIZE_FILE_COPY`. Alternatively, `FS_CopyFileEx()` can be used that lets the application specify a copy buffer of an arbitrary size.

`FS_CopyFile()` overwrites the destination file if it exists. The destination file has to be writable, that is the `FS_ATTR_READ_ONLY` flag is set to 0.

Example

```
#include "FS.h"

void SampleCopyFile(void) {
    FS_CopyFile("Src.txt", "ram:\\Dest.txt");
}
```

4.6.2 FS_CopyFileEx()

Description

Copies a file.

Prototype

```
int FS_CopyFileEx(const char * sFileNameSrc,
                 const char * sFileNameDest,
                 void * pBuffer,
                 U32 NumBytes);
```

Parameters

Parameter	Description
<code>sFileNameSrc</code>	Name of the source file (fully qualified).
<code>sFileNameDest</code>	Name of the destination file (fully qualified).
<code>pBuffer</code>	Buffer to temporary store the copied data. It cannot be NULL.
<code>NumBytes</code>	Size of the buffer size in bytes.

Return value

= 0 OK, the file has been copied.
 ≠ 0 Error code indicating the failure reason.

Additional information

The copy process uses an external buffer provided by the application. `FS_CopyFile()` overwrites the destination file if it exists. The destination file has to be writable, that is the `FS_ATTR_READ_ONLY` flag is set to 0.

The best performance is achieved when the copy buffer is a multiple of sector size and is 32-bit aligned. For example using a 7 KB copy buffer to copy 512 byte sectors is more efficient than using a copy buffer of 7.2 KB therefore the function rounds down the size of the copy buffer to a multiple of sector size. If the application specifies a copy buffer smaller than the sector size a warning is generated in debug builds indicating that the performance of the copy operation is not optimal.

Example

```
#include "FS.h"

static U32 _aBuffer[1024 / 4]; // Buffer to be used as temporary storage.

void SampleCopyFileEx(void) {
    FS_CopyFileEx("Src.txt", "Dest.txt", _aBuffer, sizeof(_aBuffer));
}
```

4.6.3 FS_GetFileAttributes()

Description

Queries the attributes of a file or directory.

Prototype

```
U8 FS_GetFileAttributes(const char * sName);
```

Parameters

Parameter	Description
sName	Name of the file or directory to be queried.

Return value

= 0xFF An error occurred.

≠ 0xFF Bit mask containing the attributes of file or directory.

Additional information

The return value is an or-combination of the following attributes: FS_ATTR_READ_ONLY, FS_ATTR_HIDDEN, FS_ATTR_SYSTEM, FS_ATTR_ARCHIVE, or FS_ATTR_DIRECTORY.

Example

```
#include <stdio.h>
#include "FS.h"

void SampleGetFileAttributes(void) {
    U8 Attr;
    char ac[100];

    Attr = FS_GetFileAttributes("Test.txt");
    if (Attr == 0xFF) {
        FS_X_Log("ERROR: Could not get the file attributes.\n");
    } else {
        SEGGER_sprintf(ac, sizeof(ac),
            "File attributes: %c%c%c%c\n",
            (Attr & FS_ATTR_READ_ONLY) ? 'R' : '-',
            (Attr & FS_ATTR_HIDDEN) ? 'H' : '-',
            (Attr & FS_ATTR_SYSTEM) ? 'S' : '-',
            (Attr & FS_ATTR_ARCHIVE) ? 'A' : '-',
            (Attr & FS_ATTR_DIRECTORY) ? 'D' : '-');
        FS_X_Log(ac);
    }
}
```

4.6.4 FS_GetFileInfo()

Description

Returns information about a file or directory.

Prototype

```
int FS_GetFileInfo(const char * sName,
                  FS_FILE_INFO * pInfo);
```

Parameters

Parameter	Description
sName	Name of the file or directory.
pInfo	out Information about file or directory.

Return value

= 0 OK, information returned.
 ≠ 0 An error occurred.

Additional information

The function returns information about the attributes, size and time stamps of the specified file or directory. For more information refer to FS_FILE_INFO.

Example

```
#include <stdio.h>
#include "FS.h"

void SampleGetFileInfo(void) {
    int r;
    FS_FILE_INFO FileInfo;
    char ac[100];
    FS_FILETIME FileTime;

    r = FS_GetFileInfo("Test.txt", &FileInfo);
    if (r == 0) {
        FS_X_Log("File info:");
        SEGGER_sprintf(ac, sizeof(ac), " Attributes: 0x%x", FileInfo.Attributes);
        FS_X_Log(ac);
        SEGGER_sprintf(ac, sizeof(ac), " Size: %ld bytes", FileInfo.FileSize);
        FS_X_Log(ac);
        FS_TimeStampToFileTime(FileInfo.CreationTime, &FileTime);
        SEGGER_sprintf(ac, sizeof(ac), " Creation time: %d-%.2d-%.2d %.2d:%.2d:%.2d",
            FileTime.Year, FileTime.Month, FileTime.Day,
            FileTime.Hour, FileTime.Minute, FileTime.Second);
        FS_X_Log(ac);
        FS_TimeStampToFileTime(FileInfo.LastAccessTime, &FileTime);
        SEGGER_sprintf(ac, sizeof(ac), " Access time: %d-%.2d-%.2d %.2d:%.2d:%.2d",
            FileTime.Year, FileTime.Month, FileTime.Day,
            FileTime.Hour, FileTime.Minute, FileTime.Second);
        FS_X_Log(ac);
        FS_TimeStampToFileTime(FileInfo.LastWriteTime, &FileTime);
        SEGGER_sprintf(ac, sizeof(ac), " Write time: %d-%.2d-%.2d %.2d:%.2d:%.2d",
            FileTime.Year, FileTime.Month, FileTime.Day,
            FileTime.Hour, FileTime.Minute, FileTime.Second);
        FS_X_Log(ac);
    }
}
```

4.6.5 FS_GetFileTime()

Description

Returns the creation time of a file or directory.

Prototype

```
int FS_GetFileTime(const char * sName,
                  U32 * pTimeStamp);
```

Parameters

Parameter	Description
<code>sName</code>	File or directory name.
<code>pTimeStamp</code>	out Receives the timestamp value.

Return value

= 0 OK, timestamp returned.
 ≠ 0 Error code indicating the failure reason.

Additional information

The date and time encoded in the timestamp using the following format:

Bit field	Description
0--4	Second divided by 2
5--10	Minute (0--59)
11--15	Hour (0--23)
16--20	Day of month (1--31)
21--24	Month (1--12, 1: January, 2: February, etc.)
25--31	Year (offset from 1980). Add 1980 to get the current year.

`FS_TimeStampToFileTime()` can be used to convert the timestamp to a `FS_FILETIME` structure that can be used to easily process the time information.

The last modification and the last access timestamps can be read via `FS_GetFileTimeEx()`.

Example

```
#include <stdio.h>
#include "FS.h"

void SampleGetFileTime(void) {
    char        ac[100];
    U32         TimeStamp;
    FS_FILETIME FileTime;
    int         r;

    r = FS_GetFileTime("Test.txt", &TimeStamp);
    if (r == 0) {
        FS_TimeStampToFileTime(TimeStamp, &FileTime);
        SEGGER_sprintf(ac, sizeof(ac), "Creation time: %d-%.2d-%.2d %.2d:%.2d:%.2d",
            FileTime.Year, FileTime.Month, FileTime.Day,
            FileTime.Hour, FileTime.Minute, FileTime.Second);
        FS_X_Log(ac);
    }
}
```

4.6.6 FS_GetFileTimeEx()

Description

Gets the timestamp of a file or directory.

Prototype

```
int FS_GetFileTimeEx(const char * sName,
                    U32 * pTimeStamp,
                    int TimeType);
```

Parameters

Parameter	Description
<code>sName</code>	File or directory name.
<code>pTimeStamp</code>	out Receives the timestamp value.
<code>TimeType</code>	Type of timestamp to return. It can take one of the following values: <ul style="list-style-type: none"> • <code>FS_FILETIME_CREATE</code> • <code>FS_FILETIME_ACCESS</code> • <code>FS_FILETIME_MODIFY</code>

Return value

= 0 OK, timestamp returned.
≠ 0 Error code indicating the failure reason.

Additional information

Refer to `FS_GetFileTime()` for a description of the timestamp format. `FS_TimeStampToFileTime()` can be used to convert the timestamp to a `FS_FILETIME` structure that can be used to easily process the time information.

EFS maintains only one filestamp that is updated when the file is created and updated therefore the same timestamp value is returned for all time types.

Example

```
#include <stdio.h>
#include "FS.h"

void SampleGetFileTimeEx(void) {
    char        ac[100];
    U32         TimeStamp;
    FS_FILETIME FileTime;
    int         r;

    r = FS_GetFileTimeEx("Test.txt", &TimeStamp, FS_FILETIME_MODIFY);
    if (r == 0) {
        FS_TimeStampToFileTime(TimeStamp, &FileTime);
        SEGGER_sprintf(ac, sizeof(ac), "Modify time: %d-%.2d-%.2d %.2d:%.2d:%.2d",
            FileTime.Year, FileTime.Month, FileTime.Day,
            FileTime.Hour, FileTime.Minute, FileTime.Second);
        FS_X_Log(ac);
    }
}
```

4.6.7 FS_ModifyFileAttributes()

Description

Sets / clears the attributes of a file or directory.

Prototype

```
U8 FS_ModifyFileAttributes(const char * sName,
                          U8      SetMask,
                          U8      ClrMask);
```

Parameters

Parameter	Description
<code>sName</code>	Name of the file or directory.
<code>SetMask</code>	Bit mask of the attributes to be set.
<code>ClrMask</code>	Bit mask of the attributes to be cleared.

Return value

= 0xFF An error occurred.

≠ 0xFF Bit mask containing the old attributes of the file or directory.

Additional information

This function can be used to set and clear at the same time the attributes of a file or directory. The `FS_ATTR_DIRECTORY` attribute cannot be modified using this function.

The return value is an or-combination of the following attributes: `FS_ATTR_READ_ONLY`, `FS_ATTR_HIDDEN`, `FS_ATTR_SYSTEM`, `FS_ATTR_ARCHIVE`, or `FS_ATTR_DIRECTORY`.

The attributes that are specified in the `SetMask` are set to 1 while the attributes that are specified in the `ClrMask` are set to 0. `SetMask` and `ClrMask` values are an or-combination of the following attributes: `FS_ATTR_READ_ONLY`, `FS_ATTR_HIDDEN`, `FS_ATTR_SYSTEM`, or `FS_ATTR_ARCHIVE`. The attributes that are not specified nor in `SetMask` either in `ClrMask` are not modified.

Example

```
#include <stdio.h>
#include "FS.h"

void SampleModifyFileAttributes(void) {
    U8  Attr;
    char ac[100];

    //
    // Set the read-only and the hidden flags. Clear archive flag.
    //
    Attr = FS_ModifyFileAttributes("Test.txt",
                                  FS_ATTR_READ_ONLY | FS_ATTR_HIDDEN,
                                  FS_ATTR_ARCHIVE);
    SEGGER_sprintf(ac, sizeof(ac), "Old file attributes: %c%c%c%c\n",
                  (Attr & FS_ATTR_READ_ONLY) ? 'R' : '-',
                  (Attr & FS_ATTR_HIDDEN)    ? 'H' : '-',
                  (Attr & FS_ATTR_SYSTEM)    ? 'S' : '-',
                  (Attr & FS_ATTR_ARCHIVE)   ? 'A' : '-',
                  (Attr & FS_ATTR_DIRECTORY) ? 'D' : '-');
    FS_X_Log(ac);
    Attr = FS_GetFileAttributes("Test.txt");
    SEGGER_sprintf(ac, sizeof(ac), "New file attributes: %c%c%c%c\n",
                  (Attr & FS_ATTR_READ_ONLY) ? 'R' : '-',
                  (Attr & FS_ATTR_HIDDEN)    ? 'H' : '-',
                  (Attr & FS_ATTR_SYSTEM)    ? 'S' : '-',
                  (Attr & FS_ATTR_ARCHIVE)   ? 'A' : '-',
                  (Attr & FS_ATTR_DIRECTORY) ? 'D' : '-');
```

```
    FS_X_Log(ac);  
}
```

4.6.8 FS_Move()

Description

Moves a file or directory to another location.

Prototype

```
int FS_Move(const char * sNameSrc,
            const char * sNameDest);
```

Parameters

Parameter	Description
<code>sNameSrc</code>	Name of the source file or directory (partially qualified). Cannot be <code>NULL</code> .
<code>sNameDest</code>	Name of the destination file or directory (partially qualified). Cannot be <code>NULL</code> .

Return value

= 0 OK, file has been moved.
 ≠ 0 Error code indicating the failure reason.

Additional information

`FS_Move()` can be used to relocate a file to another location on the same or on a different volume either in the same in a different directory. If the source and the destination files are located on the same volume, the file is moved, otherwise the file is copied and the source is deleted.

The function is also able to move and entire directory trees when the source and destination are located on the same volume. Moving an entire directory tree on a different volume is not supported. This operation has to be performed in the application by iterating over the files and directories and by copying them one-by-one.

By default, the source files and directories that have the `FS_ATTR_READ_ONLY` attribute set and that are located on a volume formatted as FAT cannot be moved. This behavior can be changed by compiling the file system sources with `FS_FAT_PERMIT_RO_FILE_MOVE` configuration define to 1. `FS_FAT_ConfigROFileMovePermission()` can be used to change the behavior at runtime.

Source files and directories located on a EFS formatted volume can be moved even if they have the `FS_ATTR_READ_ONLY` attribute set.

The operation fails if the destination file or directory already exists.

Example

```
#include "FS.h"

void SampleMove(void) {
    //
    // File tree before the operation.
    //
    // <root>
    // |
    // +-->SubDir2
    //     |
    //     +-->SubDir3
    //
    FS_Move("SubDir1", "SubDir2\\SubDir3");
    //
    // File tree after the operation.
    //
    // <root>
    // |
```

```
// +-->SubDir1  
// |  
// +-->SubDir2  
//  
}
```

4.6.9 FS_Remove()

Description

Removes a file.

Prototype

```
int FS_Remove(const char * sFileName);
```

Parameters

Parameter	Description
sFileName	Name of the file to be removed.

Return value

= 0 OK, file has been removed.
≠ 0 Error code indicating the failure reason.

Additional information

The function removes also files that have the `FS_ATTR_READ_ONLY` attribute set. The remove operation fails if the file to be deleted is open.

Example

```
#include "FS.h"

void SampleRemove(void) {
    FS_Remove("Test.txt");
}
```

4.6.10 FS_Rename()

Description

Changes the name of a file or directory.

Prototype

```
int FS_Rename(const char * sNameOld,
             const char * sNameNew);
```

Parameters

Parameter	Description
sNameOld	Old file or directory name (including the path).
sNameNew	New file or directory name (without path).

Return value

= 0 OK, file or directory has been renamed.
 ≠ 0 Error code indicating the failure reason.

Additional information

The function can rename either a file or a directory.

By default, the files and directories that have the `FS_ATTR_READ_ONLY` attribute set and that are located on a volume formatted as FAT cannot be renamed. This behavior can be changed by compiling the file system sources with the `FS_FAT_PERMIT_RO_FILE_MOVE` configuration define to 1. `FS_FAT_ConfigROFileMovePermission()` can be used to change the behavior at runtime.

Source files and directories located on a EFS formatted volume can be moved event if they have the `FS_ATTR_READ_ONLY` attribute set.

Example

```
#include "FS.h"

void SampleRename(void) {
    //
    // File tree before the operation.
    //
    // <root>
    // |
    // +-->SubDir2
    //     |
    //     +-->SubDir3
    //
    FS_Rename("SubDir2\\SubDir3", "SubDir1");
    //
    // File tree after the operation.
    //
    // <root>
    // |
    // +-->SubDir1
    //     |
    //     +-->SubDir3
    //
}
```

4.6.11 FS_SetFileAttributes()

Description

Modifies all the attributes of a file or directory.

Prototype

```
int FS_SetFileAttributes(const char * sName,
                        U8      AttrMask);
```

Parameters

Parameter	Description
<code>sName</code>	Pointer to a name of the file/directory.
<code>AttrMask</code>	Bit mask of the attributes to be set.

Return value

= 0 OK, attributes have been set.
 ≠ 0 Error code indicating the failure reason.

Additional information

The `FS_ATTR_DIRECTORY` attribute cannot be modified using this function. The value of `AttrMask` parameter is an or-combination of the following attributes: `FS_ATTR_READ_ONLY`, `FS_ATTR_HIDDEN`, `FS_ATTR_SYSTEM`, `FS_ATTR_ARCHIVE`, or `FS_ATTR_DIRECTORY`. The attributes that are not set in `AttrMask` are set to 0.

Example

```
#include <stdio.h>
#include "FS.h"

void SampleFileAttributes(void) {
    U8  Attr;
    char ac[100];

    FS_SetFileAttributes("Test.txt", FS_ATTR_HIDDEN);
    Attr = FS_GetFileAttributes("Test.txt");
    SEGGER_sprintf(ac, sizeof(ac), "File attributes: %c%c%c%c%c\n",
        (Attr & FS_ATTR_READ_ONLY) ? 'R' : '-',
        (Attr & FS_ATTR_HIDDEN)     ? 'H' : '-',
        (Attr & FS_ATTR_SYSTEM)    ? 'S' : '-',
        (Attr & FS_ATTR_ARCHIVE)   ? 'A' : '-',
        (Attr & FS_ATTR_DIRECTORY) ? 'D' : '-');
    FS_X_Log(ac);
}
```

4.6.12 FS_SetFileBuffer()

Description

Assigns a file buffer to an opened file.

Prototype

```
int FS_SetFileBuffer(FS_FILE * pFile,
                    void * pData,
                    I32 NumBytes,
                    int Flags);
```

Parameters

Parameter	Description
<code>pFile</code>	Handle to opened file.
<code>pData</code>	Pointer to the to memory area which should be used as buffer.
<code>NumBytes</code>	Number of bytes in the buffer.
<code>Flags</code>	Specifies the operating mode of the file buffer. <ul style="list-style-type: none"> • 0 Read file buffer. • <code>FS_FILE_BUFFER_WRITE</code> Read / write file buffer. • <code>FS_FILE_BUFFER_ALIGNED</code> Logical sector boundary alignment.

Return value

= 0 OK, buffer assigned.
≠ 0 Error code indicating the failure reason.

Additional information

This function has to be called immediately after the file is opened and before any read or write operation is performed on the file. If the file buffer is configured in write mode the data of any operation that writes less bytes at once than the size of the file buffer is stored to file buffer. The contents of the file buffer is written to file in the following cases:

- when the file buffer is full.
- when place is required for new data read from file.
- when closing the file via `FS_FClose()`.
- when synchronizing the file to storage via `FS_SyncFile()`.
- when unmounting the file system via `FS_Unmount()` or `FS_UnmountForced()`.
- when the file system is synchronized via `FS_Sync()`.

In case of a read operation if the data is not present in the file buffer the file system fills the entire file buffer with the data from file.

`FS_SetFileBuffer` reports an error if the file system is configured to automatically allocate a file buffer for each file it opens via `FS_ConfigFileBufferDefault()`.

The data required to manage the file buffer is allocated from `pData`. The `FS_SIZE-OF_FILE_BUFFER()` define can be used to calculate the amount of RAM required to store a specified number of data bytes in the file buffer.

If the file is opened and closed in the same function the file buffer can be allocated locally on the stack. Otherwise the buffer has to be globally allocated. After the file is closed the memory allocated for the file buffer is no longer accessed by the file system and can be safely deallocated or used to store other data.

`FS_SetFileBuffer()` is available if the emFile sources are compiled with the `FS_SUPPORT_FILE_BUFFER` configuration define set to 1.

Example

```
#include "FS.h"

void SampleSetFileBuffer(void) {
    FS_FILE * pFile;
    U32      aBuffer[FS_SIZEOF_FILE_BUFFER(512) / 4];

    pFile = FS_FOpen("Test.txt", "w");
    if (pFile != NULL) {
        //
        // Set the file buffer for read and write operation.
        // The file buffer is allocated on the stack since the file
        // is closed before the function returns.
        //
        FS_SetFileBuffer(pFile, aBuffer, sizeof(aBuffer), FS_FILE_BUFFER_WRITE);
        //
        // Data is written to file buffer.
        //
        FS_Write(pFile, "Test", 4);
        //
        // Write the data from file buffer to storage and close the file.
        //
        FS_FClose(pFile);
    }
}
```

4.6.13 FS_SetFileTime()

Description

Sets the creation time of a file or directory.

Prototype

```
int FS_SetFileTime(const char * sName,
                  U32      TimeStamp);
```

Parameters

Parameter	Description
sName	File or directory name.
TimeStamp	The value of the timestamp to be set.

Return value

= 0 OK, timestamp modified.
 ≠ 0 Error code indicating the failure reason.

Additional information

Refer to `FS_GetFileTime()` for a description of the timestamp format. `FS_FileTimeToTimeStamp()` can be used to convert a `FS_FILETIME` structure to a timestamp that can be used in a call to `FS_SetFileTime()`.

This function is optional. The file system updates automatically the timestamps of file or directories.

Example

```
#include "FS.h"

void SampleSetFileTime(void) {
    U32      TimeStamp;
    FS_FILETIME FileTime;

    FileTime.Year   = 2005;
    FileTime.Month  = 03;
    FileTime.Day    = 26;
    FileTime.Hour   = 10;
    FileTime.Minute = 56;
    FileTime.Second = 14;
    FS_FileTimeToTimeStamp (&FileTime, &TimeStamp);
    FS_SetFileTime("Test.txt", TimeStamp);
}
```

4.6.14 FS_SetFileTimeEx()

Description

Sets the timestamp of a file or directory.

Prototype

```
int FS_SetFileTimeEx(const char * sName,
                    U32      TimeStamp,
                    int      TimeType);
```

Parameters

Parameter	Description
<code>sName</code>	File or directory name.
<code>TimeStamp</code>	The value of the timestamp to be set.
<code>TimeType</code>	Type of timestamp to be modified. It can take of the following values: <ul style="list-style-type: none"> • <code>FS_FILETIME_CREATE</code> • <code>FS_FILETIME_ACCESS</code> • <code>FS_FILETIME_MODIFY</code>

Return value

= 0 OK, timestamp modified.
≠ 0 Error code indicating the failure reason.

Additional information

Refer to `FS_GetFileTime()` for a description of the timestamp format. `FS_FileTimeToTimeStamp()` can be used to convert a `FS_FILETIME` structure to a timestamp that can be used in a call to `FS_SetFileTimeEx()`.

EFS maintains only one filestamp therefore the `TimeType` parameter is ignored for files and directories stored on an EFS volume.

This function is optional. The file system updates automatically the timestamps of file or directories.

Example

```
#include "FS.h"

void SampleSetFileTime(void) {
    U32      TimeStamp;
    FS_FILETIME FileTime;

    FileTime.Year   = 2017;
    FileTime.Month  = 07;
    FileTime.Day    = 07;
    FileTime.Hour   = 14;
    FileTime.Minute = 48;
    FileTime.Second = 14;
    FS_FileTimeToTimeStamp(&FileTime, &TimeStamp);
    //
    // Set the access time of the file.
    //
    FS_SetFileTimeEx("Test.txt", TimeStamp, FS_FILETIME_ACCESS);
}
```

4.6.15 FS_WipeFile()

Description

Overwrites the contents of a file with random data.

Prototype

```
int FS_WipeFile(const char * sFileName);
```

Parameters

Parameter	Description
sFileName	Name of the file to overwrite.

Return value

= 0 Contents of the file overwritten.
 ≠ 0 Error code indicating the failure reason.

Additional information

When a file is removed, the file system marks the corresponding directory entry and the clusters in the allocation table as free. The contents of the file is not modified and it can be in theory restored by using a disk recovery tool. This can be a problem if the file stores sensitive data. Calling FS_WipeFile() before the file is removed makes the recovery of data impossible.

This function allocates FS_BUFFER_SIZE_FILE_WIPE bytes on the stack.

Example

```
#include "FS.h"

void SampleWipeFile(void) {
    FS_FILE * pFile;

    //
    // Create a file and write data to it.
    //
    pFile = FS_FOpen("Test.txt", "w");
    if (pFile) {
        FS_Write(pFile, "12345", 5);
        FS_FClose(pFile);
        //
        // Overwrite the file contents with random data.
        //
    }
    FS_WipeFile("Test.txt");
    //
    // Delete the file from storage medium.
    //
    FS_Remove("Test.txt");
}
```

4.6.16 File attributes

Description

Attributes of files and directories.

Definition

```
#define FS_ATTR_READ_ONLY      0x01u
#define FS_ATTR_HIDDEN        0x02u
#define FS_ATTR_SYSTEM        0x04u
#define FS_ATTR_ARCHIVE       0x20u
#define FS_ATTR_DIRECTORY     0x10u
```

Symbols

Definition	Description
FS_ATTR_READ_ONLY	The file is read-only. Applications can read the file but cannot write to it.
FS_ATTR_HIDDEN	The file or directory is marked as hidden. Most of operating systems do not include these files in an ordinary directory listing. This flag is not evaluated by emFile.
FS_ATTR_SYSTEM	The file or directory is part of, or is used exclusively by, the operating system. This flag is not evaluated by emFile.
FS_ATTR_ARCHIVE	The file or directory is an archive file or directory. Applications can use this attribute to mark files for backup or removal. This flag is not evaluated by emFile.
FS_ATTR_DIRECTORY	The file is actually a directory.

4.6.17 FS_FILE_INFO

Description

Information about a file or directory.

Type definition

```
typedef struct {
    U8   Attributes;
    U32  CreationTime;
    U32  LastAccessTime;
    U32  LastWriteTime;
    U32  FileSize;
} FS_FILE_INFO;
```

Structure members

Member	Description
Attributes	File or directory attributes.
CreationTime	Date and time when the file was created.
LastAccessTime	Date and time when the file was accessed last.
LastWriteTime	Date and time when the file was written to last.
FileSize	Size of the file in bytes.

Additional information

The [Attributes](#) member is an bitwise-or combination of the following flags: `FS_ATTR_READ_ONLY`, `FS_ATTR_HIDDEN`, `FS_ATTR_SYSTEM`, `FS_ATTR_ARCHIVE`, or `FS_ATTR_DIRECTORY`.

For directories the [FileSize](#) member is always 0.

4.6.18 File time types

Description

Types of timestamps available for a file or directory.

Definition

```
#define FS_FILETIME_CREATE    0
#define FS_FILETIME_ACCESS   1
#define FS_FILETIME_MODIFY   2
```

Symbols

Definition	Description
FS_FILETIME_CREATE	Date and time when the file or directory was created.
FS_FILETIME_ACCESS	Date and time of the last read access to file or directory.
FS_FILETIME_MODIFY	Date and time of the last write access to file or directory.

4.7 Directory functions

This section describes functions that operate on directories. API functions are provided for creating, deleting and listing directories.

4.7.1 FS_CreateDir()

Description

Creates a directory including any missing directories from path.

Prototype

```
int FS_CreateDir(const char * sDirName);
```

Parameters

Parameter	Description
sDirName	Directory name.

Return value

- = 0 Directory path has been created.
- = 1 Directory path already exists.
- < 0 Error code indicating the failure reason.

Additional information

The function creates automatically any subdirectories that are specified in the path but do not exist on the storage.

FS_CreateDir() uses a work buffer of FS_MAX_PATH bytes allocated on the stack for parsing the path to directory.

Example

```
#include "FS.h"

void SampleCreateDir(void) {
    //
    // File tree before the operation.
    //
    // <root>
    // |
    // +-->SubDir1
    //
    FS_CreateDir("SubDir1\\SubDir2\\SubDir3");
    //
    // File tree after the operation.
    //
    // <root>
    // |
    // +-->SubDir1
    //     |
    //     +-->SubDir2
    //         |
    //         +-->SubDir3
    //
}
```

4.7.2 FS_DeleteDir()

Description

Removes a directory and its contents.

Prototype

```
int FS_DeleteDir(const char * sDirName,
                int      MaxRecursionLevel);
```

Parameters

Parameter	Description
<code>sDirName</code>	Directory name.
<code>MaxRecursionLevel</code>	Maximum depth of the directory tree.

Return value

= 0 OK, directory has been removed
 ≠ 0 Error code indicating the failure reason

Additional information

The function uses recursion to process the directory tree and it requires about 100 bytes of stack for each directory level it processes. The `MaxRecursionLevel` parameter can be used to prevent a stack overflow if the directory tree is too deep. For example:

- `MaxRecursionLevel=0` Deletes the directory only if empty else an error is reported and the directory is not deleted.
- `MaxRecursionLevel=1` Deletes the directory and all the files in it. If a subdirectory is present an error is reported and the directory is not deleted.
- `MaxRecursionLevel=2` Deletes the directory and all the files and subdirectories in it. If the subdirectories contain other subdirectories an error is reported and the directory is not deleted.
- And so on...

Example

```
#include "FS.h"

void SampleDeleteDir(void) {
    //
    // File tree before the operation.
    //
    // <root>
    // |
    // +-->SubDir1
    // |
    // +-->SubDir2
    //     |
    //     +-->File1.txt
    //     |
    //     +-->File2.txt
    //
    FS_DeleteDir("SubDir2", 1);
    //
    // File tree after the operation.
    //
    // <root>
    // |
    // +-->SubDir1
    //
}
```

4.7.3 FS_FindClose()

Description

Ends a directory scanning operation.

Prototype

```
void FS_FindClose(FS_FIND_DATA * pFD);
```

Parameters

Parameter	Description
pFD	Context of the directory scanning operation.

Additional information

This function has to be called at the end of the directory scanning operation to clear the used context. After calling this function the same context can be used for a different directory scanning operation.

Example

```
#include "FS.h"

void SampleFindClose(void) {
    FS_FIND_DATA fd;
    int          r;
    char         acFileName[32];

    //
    // List the files from the root directory.
    //
    r = FS_FindFirstFile(&fd, "", acFileName, sizeof(acFileName));
    if (r == 0) {
        do {
            //
            // Process file or directory...
            //
        } while (FS_FindNextFile(&fd));
    }
    FS_FindClose(&fd);
    //
    // List the files from the "SubDir1" directory.
    //
    r = FS_FindFirstFile(&fd, "SubDir1", acFileName, sizeof(acFileName));
    if (r == 0) {
        do {
            //
            // Process file or directory...
            //
        } while (FS_FindNextFile(&fd));
    }
    FS_FindClose(&fd);
}
```

4.7.4 FS_FindFirstFile()

Description

Initiates a directory scanning operation and returns information about the first file or directory.

Prototype

```
int FS_FindFirstFile(    FS_FIND_DATA * pFD,
                        const char    * sDirName,
                        char          * sFileName,
                        int            SizeOfFileName);
```

Parameters

Parameter	Description
<code>pFD</code>	Context of the directory scanning operation.
<code>sDirName</code>	Name of the directory to search in.
<code>sFileName</code>	Buffer that receives the name of the file found.
<code>SizeOfFileName</code>	Size in bytes of the <code>sFileName</code> buffer.

Return value

= 0 O.K.
 = 1 No files or directories available in directory.
 < 0 Error code indicating the failure reason.

Additional information

This function returns information about the first file or directory found in the directory. This is typically the special directory name "." when searching in a directory other than root. `FS_FindFirstFile()` and `FS_FindNextFile()` can be used to list all the files and directories in a directory.

The name of the file or directory is returned in `sFileName`. `FS_FindFirstFile()` stores at most `SizeOfFileName - 1` characters in the buffer and it terminates the name of file or directory by a 0 character. The file or directory name is truncated if it contains more characters than the number of characters that can be stored in `sFileName`. For files or directories stored on a FAT volume with LFN support the name is truncated by returning the short version (8.3 format) of the file or directory name.

Alternatively, the file name can be accessed via the `sFileName` member of the `pFD` structure. Additional information about the file or directory such as size, attributes and timestamps are returned via the corresponding members of `pFD` structure. For more information refer to `FS_FIND_DATA`.

The returned file or directory does not necessarily be the first file or directory created in the root directory. The name of the first file or directory can change as files are deleted and created in the root directory.

Example

```
#include <stdio.h>
#include "FS.h"

void SampleFindFirstFile(void) {
    FS_FIND_DATA fd;
    int         r;
    char        acFileName[32];
    char        ac[100];
    FS_FILETIME FileTime;

    //
```

```

// List the files from the "SubDir1" directory.
//
r = FS_FindFirstFile(&fd, "SubDir1", acFileName, sizeof(acFileName));
if (r == 0) {
do {
//
// Ignore "." and ".." entries.
//
if (fd.sFileName[0] == '.') {
continue;
}
//
// Show information about the file.
//
if (fd.Attributes & FS_ATTR_DIRECTORY) {
SEGGER_sprintf(ac, sizeof(ac), "Directory name: %s\n", fd.sFileName);
} else {
SEGGER_sprintf(ac, sizeof(ac), "File name: %s\n", fd.sFileName);
}
FS_X_Log(ac);
SEGGER_sprintf(ac, sizeof(ac), "File size: %lu\n", fd.FileSize);
FS_X_Log(ac);
SEGGER_sprintf(ac, sizeof(ac), "Attributes: %c%c%c%c\n",
(fd.Attributes & FS_ATTR_READ_ONLY) ? 'R' : '-',
(fd.Attributes & FS_ATTR_HIDDEN) ? 'H' : '-',
(fd.Attributes & FS_ATTR_SYSTEM) ? 'S' : '-',
(fd.Attributes & FS_ATTR_ARCHIVE) ? 'A' : '-',
(fd.Attributes & FS_ATTR_DIRECTORY) ? 'D' : '-');
FS_X_Log(ac);
FS_TimeStampToFileTime(fd.CreationTime, &FileTime);
SEGGER_sprintf(ac, sizeof(ac), "Creation time: %d-%.2d-%.2d %.2d:%.2d:%.2d",
FileTime.Year, FileTime.Month, FileTime.Day,
FileTime.Hour, FileTime.Minute, FileTime.Second);
FS_X_Log(ac);
FS_TimeStampToFileTime(fd.LastAccessTime, &FileTime);
SEGGER_sprintf(ac, sizeof(ac), "Access time: %d-%.2d-%.2d %.2d:%.2d:%.2d",
FileTime.Year, FileTime.Month, FileTime.Day,
FileTime.Hour, FileTime.Minute, FileTime.Second);
FS_X_Log(ac);
FS_TimeStampToFileTime(fd.LastWriteTime, &FileTime);
SEGGER_sprintf(ac, sizeof(ac), "Write time: %d-%.2d-%.2d %.2d:%.2d:%.2d",
FileTime.Year, FileTime.Month, FileTime.Day,
FileTime.Hour, FileTime.Minute, FileTime.Second);
FS_X_Log(ac);
FS_X_Log("--\n");
} while (FS_FindNextFile(&fd));
}
FS_FindClose(&fd);
}

```

4.7.5 FS_FindNextFile()

Description

Returns information about the next file or directory in a directory scanning operation.

Prototype

```
int FS_FindNextFile(FS_FIND_DATA * pFD);
```

Parameters

Parameter	Description
<code>pFD</code>	Context of the directory scanning operation.

Return value

- 1 O.K.
- 0 Error occurred or end of directory reached.

Additional information

`FS_FindNextFile()` returns information about the next file or directory located after the file or directory returned via a previous call to `FS_FindFirstFile()` or `FS_FindNextFile()` within the same listing context.

The name of the file or directory is returned in `sFileName` member of `pFD`. `FS_FindNextFile()` stores at most one less than the buffer size characters in the buffer and it terminates the name of the file or directory by a 0 character. The buffer for the file or directory name is specified in the call to `FS_FindFirstFile()`. The file or directory name is truncated if it contains more characters than the number of characters that can be stored in `sFileName`. For files or directories stored on a FAT volume with LFN support the name is truncated by returning the short version (8.3 format) of the file or directory name.

Additional information about the file or directory such as size, attributes and timestamps are returned via the corresponding members of `pFD` structure. For more information refer to `FS_FIND_DATA`.

`FS_FindFirstFile()` has to be called first to initialize the listing operation. It is allowed to perform operations on files or directories (creation, deletion, etc.) within the listing loop.

Example

Refer to the example of `FS_FindFirstFile()`

4.7.6 FS_FindNextFileEx()

Description

Returns information about the next file or directory in a directory scanning operation.

Prototype

```
int FS_FindNextFileEx(FS_FIND_DATA * pFD);
```

Parameters

Parameter	Description
<code>pFD</code>	Context of the directory scanning operation.

Return value

- = 1 No files or directories available in directory.
- = 0 OK, information about the file or directory returned.
- < 0 Error code indicating the failure reason.

Additional information

`FS_FindNextFileEx()` performs the same operation as `FS_FindNextFile()` with the difference that its return value is consistent with the return value of the other emFile API functions.

4.7.7 FS_Mkdir()

Description

Creates a directory.

Prototype

```
int FS_Mkdir(const char * sDirName);
```

Parameters

Parameter	Description
sDirName	Directory name.

Return value

= 0 OK, directory has been created
≠ 0 Error code indicating the failure reason

Additional information

The function fails if a directory with the same name already exists in the target directory. FS_Mkdir() expects that all the directories in the path to the created directory exists. Otherwise the function returns with an error. FS_CreateDir() can be used to create a directory along with any missing directories in the path.

Example

```
#include "FS.h"

void SampleMkdir(void) {
    FS_Mkdir("SubDir1");
}
```

4.7.8 FS_RmDir()

Description

Removes a directory.

Prototype

```
int FS_RmDir(const char * sDirName);
```

Parameters

Parameter	Description
sDirName	Directory name.

Return value

= 0 OK, directory has been removed
≠ 0 Error code indicating the failure reason

Additional information

The function fails if the directory is not empty. FS_DeleteDir() can be used to remove a directory and its contents.

Example

```
#include "FS.h"

void SampleRmDir(void) {
    FS_RmDir("SubDir1");
}
```

4.7.9 FS_FIND_DATA

Description

Information about a file or directory.

Type definition

```
typedef struct {
    U8      Attributes;
    U32     CreationTime;
    U32     LastAccessTime;
    U32     LastWriteTime;
    U32     FileSize;
    char *  sFileName;
    int     SizeofFileName;
    FS_DIR  Dir;
} FS_FIND_DATA;
```

Structure members

Member	Description
Attributes	Attributes of the file or directory.
CreationTime	Date and time when the file or directory was created.
LastAccessTime	Date and time when the file or directory was accessed last.
LastWriteTime	Date and time when the file or directory was modified last.
FileSize	Size of the file. Set to 0 for a directory.
sFileName	Name of the file or directory as 0-terminated string. It points to the buffer passed as argument to <code>FS_FindFirstFile()</code> .
SizeofFileName	Internal. Do not use.
Dir	Internal. Do not use.

Additional information

This structure contains also the context for the file listing operation. These members are considered internal and should not be used by the application. `FS_FIND_DATA` is used as context by the `FS_FindFirstFile()` and `FS_FindNextFile()` pair of functions.

4.8 Formatting functions

A storage device has to be formatted before it can be used to write data to it. SD and MMC memory cards as well as USB drives are usually already preformatted. Normally, the NAND and NOR flash devices have to be reformatted. These storage devices require a low-level format first, followed by a high-level format. The low-level format is device-specific while the high-level format depends on the type of file system.

4.8.1 FS_Format()

Description

Performs a high-level format.

Prototype

```
int FS_Format(const char          * sVolumeName,
              const FS_FORMAT_INFO * pFormatInfo);
```

Parameters

Parameter	Description
<code>sVolumeName</code>	Volume name.
<code>pFormatInfo</code>	in Additional format information. Can be NULL.

Return value

= 0 OK, storage device formatted successfully.
 ≠ 0 Error code indicating the failure reason.

Additional information

The high-level format operation has to be performed once before using the storage device for the first time. `FS_Format()` stores the management information required by the file system on the storage device. This means primarily the initialization of the allocation table and of the root directory, as well as of the BIOS Parameter Block (BPB) for a volume formatted as FAT and of the Information Sector for a volume formatted as EFS.

The type of file system can be selected at compile time via `FS_SUPPORT_FAT` and `FS_SUPPORT_EFS` defines. If both file systems are enabled at compile time the type of file system can be configured via `FS_SetFSType()`.

There are many different ways to format a medium, even with one file system. If the `pFormatInfo` parameter is not specified, reasonable default values are used (auto-format). However, `FS_Format()` allows fine-tuning of the parameters used. For increased performance it is recommended to format the storage with clusters as large as possible. The larger the cluster the smaller gets the number of accesses to the allocation table the file system has to perform during a read or write operation. For more information about format parameters see `FS_FORMAT_INFO`.

Example

```
#include <string.h>
#include "FS.h"

void SampleFormat(void) {
    FS_FORMAT_INFO FormatInfo;
    //
    // Format default volume using reasonable defaults.
    //
    FS_Format("", NULL);
    //
    // Format the "mmc:0:" volume using 32 Kbyte clusters
    // assuming that the size of the logical sector used
    // by the storage device is 512 bytes.
    //
    memset(&FormatInfo, 0, sizeof(FormatInfo));
    FormatInfo.SectorsPerCluster = 64;
    FS_Format("mmc:0:", &FormatInfo);
}
```

4.8.2 FS_FormatLLIfRequired()

Description

Performs a low-level format.

Prototype

```
int FS_FormatLLIfRequired(const char * sVolumeName);
```

Parameters

Parameter	Description
<code>sVolumeName</code>	Name of the volume to be formatted.

Return value

= 0 OK, low-level format successful.
 = 1 Low-level format not required.
 < 0 Error code indicating the failure reason.

Additional information

This function performs a low-level format of a storage device if it is not already low-level formatted. `FS_FormatLLIfRequired()` does nothing if the storage device is already low-level formatted. A storage device has to be low-level formatted once before the file system can perform any data access. All the data present on the storage device is lost after a low-level format.

The low-level format operation is required only for the storage devices that are managed by the file system such as NAND and NOR flash devices. SD cards and e.MMC devices do not require a low-level format.

Example

```
#include "FS.h"

void SampleFormatLLIfRequired(void) {
    FS_Init();
    //
    // Perform a low-level format if required.
    // Equivalent to the following sequence:
    //
    // if (FS_IsLLFormatted("nand:0:") == 0) {
    //     FS_FormatLow("nand:0:");
    // }
    //
    FS_FormatLLIfRequired("nand:0:");
}
```

4.8.3 FS_FormatLow()

Description

Performs a low-level format.

Prototype

```
int FS_FormatLow(const char * sVolumeName);
```

Parameters

Parameter	Description
<code>sVolumeName</code>	Name of the volume to be formatted.

Return value

= 0 OK, low-level format successful.
≠ 0 Error code indicating the failure reason.

Additional information

This function prepares a storage device for the data access. The file system reports an error if an attempt is made to access a storage device that is not low-level formatted. All the data present on the storage device is lost after a low-level format.

The low-level format operation has to be performed only for the storage devices that are managed by the file system such as NAND and NOR flash devices. SD cards and e.MMC devices do not require a low-level format.

Example

```
#include "FS.h"

void SampleFormatLow(void) {
    FS_Init();
    //
    // Performs a low-level format of the NOR flash.
    //
    FS_FormatLow("nor:0:");
}
```

4.8.4 FS_IsHLLFormatted()

Description

Checks if a volume is high-level formatted or not.

Prototype

```
int FS_IsHLLFormatted(const char * sVolumeName);
```

Parameters

Parameter	Description
sVolumeName	Name of the volume to be checked.

Return value

- = 1 Volume is formatted.
- = 0 Volume is not formatted.
- < 0 Error code indicating the failure reason.

Additional information

This function can be use to determine if the format of a volume is supported by the file system. If the volume format is unknown the function returns 0.

Example

```
#include "FS.h"

void SampleIsHLLFormatted(void) {
    FS_Init();
    //
    // Perform a high-level format if required.
    //
    if (FS_IsHLLFormatted("") == 0) {
        FS_Format("", NULL);
    }
}
```

4.8.5 FS_IsLLFormatted()

Description

Returns whether a volume is low-level formatted or not.

Prototype

```
int FS_IsLLFormatted(const char * sVolumeName);
```

Parameters

Parameter	Description
<code>sVolumeName</code>	Name of the volume to be checked. It cannot be <code>NULL</code> .

Return value

- = 1 Volume is low-level formatted
- = 0 Volume is not low-level formatted
- < 0 Error code indicating the failure reason

Example

```
#include "FS.h"

void SampleIsLLFormatted(void) {
    FS_Init();
    //
    // Perform a low-level format if required.
    // Equivalent to the following sequence:
    //
    // FS_FormatLLIfRequired("nor:0:");
    //
    if (FS_IsLLFormatted("nor:0:") == 0) {
        FS_FormatLow("nor:0:");
    }
}
```

4.8.6 FS_FORMAT_INFO

Description

Parameters for the high-level format.

Type definition

```
typedef struct {
    U16      SectorsPerCluster;
    U16      NumRootDirEntries;
    FS_DEV_INFO * pDevInfo;
} FS_FORMAT_INFO;
```

Structure members

Member	Description
SectorsPerCluster	Number of sectors in a cluster.
NumRootDirEntries	Number of directory entries in the root directory.
pDevInfo	Information about the storage device.

Additional information

This structure is passed as parameter to `FS_Format()` to specify additional information about how the storage device has to be formatted.

A cluster is the minimal unit size a file system can handle. Sectors are combined together to form a cluster. [SectorsPerCluster](#) has to be a power of 2 value, for example 1, 2, 4, 8, 16, 32, 64. Larger values lead to a higher read / write performance when working with large files while low values (1) make more efficient use of disk space.

- Allowed values for FAT: 1--128
- Allowed values for EFS: 1--32768

[NumRootDirEntries](#) represents the number of directory entries in the root directory should have. This is only a proposed value. The actual value depends on the FAT type. This value is typically used for FAT12 or FAT16 formatted volume that have a fixed number of entries in the root directory. On FAT32 formatted volume the root directory can grow dynamically. The file system uses a default value of 256 if [NumRootDirEntries](#) is set to 0.

[pDevInfo](#) should be typically set to `NULL` unless some specific information about the storage device has to be passed to format function. The file system requests internally the information from storage device if [pDevInfo](#) is set to `NULL`.

4.9 Partitioning functions

The functions in this section can be used to manage separate volumes on the same storage device.

4.9.1 FS_CreateGPT()

Description

Partitions the specified volume using a GPT (GUID Partition Table) partition scheme.

Prototype

```
int FS_CreateGPT(const char          * sVolumeName,
                FS_GPT_INFO         * pGPTInfo,
                FS_PARTITION_INFO_GPT * pPartInfo,
                int                  NumPartitions);
```

Parameters

Parameter	Description
<code>sVolumeName</code>	Name of the volume to be partitioned.
<code>pGPTInfo</code>	in Information about the GPT partitioning. It cannot be NULL.
<code>pPartInfo</code>	in List of the partitions to be created. It cannot be NULL.
<code>NumPartitions</code>	Number of partitions to be created. It cannot be 0 or negative.

Return value

= 0 OK, volume partitioned successfully.
 ≠ 0 Error code indicating the failure reason.

Additional information

The partition information is stored starting with the first logical sector of the storage device. The number of logical sectors occupied by the partitioning information depends on the number of partitions created. The partitioning information requires at least three logical sectors that is one logical sector for the protective MBR, one logical sector for the GPT header and one logical sector for the partition table. In addition, a copy of the GPT header and of the partition table is stored for redundancy purposes at the end of the storage device. For this reason, `FS_CreateGPT()` overwrites any information present in these logical sectors of the specified volume.

The partition entries are stored in the order specified in the `pPartInfo` array: the information found in `pPartInfo[0]` is stored to first partition entry, the information found in `pPartInfo[1]` is stored to the second partition entry, and so on.

The actual number of created partition entries is calculated as the maximum of `NumPartitions` and `pGPTInfo::NumPartitions`. If `pGPTInfo::NumPartitions` is greater than `NumPartitions` then `FS_CreateGPT()` creates empty partitions for partition indexes greater than or equal to `NumPartitions`.

`FS_CreateGPT()` calculates the values of `pGPTInfo::StartSector` and `pGPTInfo::NumSectors` based on the capacity of the storage device if these members are set to 0. If `pPartInfo::StartSector` is set to 0 then `FS_CreateGPT()` set is to the next available sector that immediately follows the previous partition entry. `pPartInfo::NumSectors` can be set to 0 only for the last partition in the list in which case the last partition occupies the remaining free space on the storage device. For any other partitions `pPartInfo::NumSectors` must be different than 0.

`FS_CreateGPT()` checks the validity of values in `pGPTInfo` and `pPartInfo`. Any misconfiguration such as overlapping partitions is reported as an error and the partition table is not created.

The partitioning information such as the disk id and the number of partitions can be queried via `FS_GetGPTInfo()`. The information about individual partitions can be obtained via `FS_GetPartitionInfoGPT()`.

The DISKPART logical driver can be used to access the data of the created partitions.

Example

```
#include <string.h>
#include "FS.h"

static const U8 _abDiskId[FS_NUM_BYTES_GUID] = {
    // FB223EF0-C45C-D24A-4787-F2E856469D59
    0xFB, 0x22, 0x3E, 0xF0,
    0xC4, 0x5C,
    0xD2, 0x4A,
    0x47, 0x87,
    0xF2, 0xE8, 0x56, 0x46, 0x9D, 0x59
};

static const U8 _abTypeBasicData[FS_NUM_BYTES_GUID] = {
    // A2A0D0EB-E5B9-3344-87C0-68B6E72699C7
    0xA2u, 0xA0u, 0xD0u, 0xEBu,
    0xE5u, 0xB9u,
    0x33u, 0x44u,
    0x87u, 0xC0u,
    0x68u, 0xB6u, 0xB7u, 0x26u, 0x99u, 0xC7
};

static const U8 _abPartId0[FS_NUM_BYTES_GUID] = {
    // E633CD2E-2D08-7C46-5E97-7283101E324D
    0xE6, 0x33, 0xCD, 0x2E,
    0x2D, 0x08,
    0x7C, 0x46,
    0x5E, 0x97,
    0x72, 0x83, 0x10, 0x1E, 0x32, 0x4D
};

static const U8 _abPartId1[FS_NUM_BYTES_GUID] = { //
    6D8195A2-A800-3442-4007-999793ECE605
    0x6D, 0x81, 0x95, 0xA2,
    0xA8, 0x00,
    0x34, 0x42,
    0x40, 0x07,
    0x99, 0x97, 0x93, 0xEC, 0xE6, 0x05
};

static const U8 _abPartId2[FS_NUM_BYTES_GUID] = { //
    621D39CB-6DD4-6448-7539-487394C67FCF
    0x62, 0x1D, 0x39, 0xCB,
    0x6D, 0xD4,
    0x64, 0x48,
    0x75, 0x39,
    0x48, 0x73, 0x94, 0xC6, 0x7F, 0xCF
};

void SampleCreateGPT(void) {
    FS_PARTITION_INFO_GPT aPartInfo[3];
    FS_GPT_INFO          gptInfo;

    //
    // This example creates a GUID partition table with three partitions.
    // The position and size of first partition is configured explicitly.
    // The position of the second partition is calculated by FS_CreateGPT()
    // and it starts right after the first partition.
    // The third partition occupies the remaining of the storage device.
    //
    memset(aPartInfo, 0, sizeof(aPartInfo));
    memset(&gptInfo, 0, sizeof(gptInfo));
    //
    // We fill here only the disk id. The information related to
    // the partition location and the number of partitions is
    // calculated by FS_CreateGPT();
    //
    memcpy(gptInfo.abId, _abDiskId, FS_NUM_BYTES_GUID);
    //
    // First partition.
    //
    aPartInfo[0].StartSector = 32;
```

```
aPartInfo[0].NumSectors = 5000;
memcpy(aPartInfo[0].abId, _abPartId0, FS_NUM_BYTES_GUID);
memcpy(aPartInfo[0].abType, _abTypeBasicData, FS_NUM_BYTES_GUID);
//
// Second partition.
//
aPartInfo[1].StartSector = 0;
aPartInfo[1].NumSectors = 10000;
memcpy(aPartInfo[1].abId, _abPartId1, FS_NUM_BYTES_GUID);
memcpy(aPartInfo[1].abType, _abTypeBasicData, FS_NUM_BYTES_GUID);
//
// Third partition.
//
aPartInfo[2].StartSector = 0;
aPartInfo[2].NumSectors = 0;
memcpy(aPartInfo[2].abId, _abPartId1, FS_NUM_BYTES_GUID);
memcpy(aPartInfo[2].abType, _abTypeBasicData, FS_NUM_BYTES_GUID);
//
// Create the partition table.
//
FS_CreateGPT("", &gptInfo, aPartInfo, 3);
}
```

4.9.2 FS_CreateMBR()

Description

Partitions the specified volume using a MBR (Master Boot Record) partition scheme.

Prototype

```
int FS_CreateMBR(const char          * sVolumeName,
                FS_PARTITION_INFO_MBR * pPartInfo,
                int                  NumPartitions);
```

Parameters

Parameter	Description
<code>sVolumeName</code>	Name of the volume to be partitioned.
<code>pPartInfo</code>	<input type="checkbox"/> List of the partitions to be created.
<code>NumPartitions</code>	Number of partitions to be created.

Return value

= 0 OK, volume partitioned successfully.
 ≠ 0 Error code indicating the failure reason.

Additional information

The Master Boot Record is a special logical sector that contains information about how the storage device is partitioned. This partitioning information is located on the first logical sector of a storage device (sector index 0). The MBR information can be queried via `FS_GetPartitionInfoMBR()`. `FS_CreateMBR()` overwrites any information present in the first logical sector of the specified volume.

The partition entries are stored in the order specified in the `pPartInfo` array: the information found in `pPartInfo[0]` is stored to first partition entry, the information found in `pPartInfo[1]` is stored to the second partition entry, and so on.

If the `Type` member of the `FS_PARTITION_INFO_MBR` structure is set to 0 then `FS_CreateMBR()` automatically calculates the partition type and the CHS (Cylinder/Head/Sector) addresses (`Type`, `StartAddr` and `EndAddr`) based on the values stored in the `StartSector` and `NumSector` members.

The data of the created partitions can be accessed using the DISKPART logical driver.

Example

```
#include <string.h>
#include "FS.h"

void SampleCreateMBR(void) {
    FS_PARTITION_INFO_MBR aPartInfo[2];

    //
    // This example creates a MBR with two partitions.
    // The first partition is configured to be bootable.
    // All parameters are explicitly configured.
    // The second partition is configured not to be bootable.
    // The partition type and CHS address are calculated
    // automatically by FS_CreateMBR().
    //
    memset(aPartInfo, 0, sizeof(aPartInfo));
    //
    // First partition.
    //
    aPartInfo[0].IsActive          = 1;
    aPartInfo[0].StartSector       = 10;
    aPartInfo[0].NumSectors        = 100000;
    aPartInfo[0].Type              = 6;
```

```
aPartInfo[0].StartAddr.Cylinder = 0;
aPartInfo[0].StartAddr.Head     = 0;
aPartInfo[0].StartAddr.Sector  = 11;
aPartInfo[0].EndAddr.Cylinder  = 538;
aPartInfo[0].EndAddr.Head      = 1;
aPartInfo[0].EndAddr.Sector    = 10;
//
// Second partition.
//
aPartInfo[1].StartSector = 200000;
aPartInfo[1].NumSectors = 10000;
FS_CreateMBR("", aPartInfo, 2);
}
```

4.9.3 FS_GetGPTInfo()

Description

Returns information about the GPT partitioning.

Prototype

```
int FS_GetGPTInfo(const char * sVolumeName,
                 FS_GPT_INFO * pGPTInfo);
```

Parameters

Parameter	Description
sVolumeName	Name of the volume on which the partition is located.
pGPTInfo	out Information about the GPT partitioning.

Return value

- = 0 OK, partition information read.
- ≠ 0 Error code indicating the failure reason.

Example

```
#include <string.h>
#include "FS.h"

void SampleGetGPTInfo(void) {
    char ac[100];
    int r;
    FS_GPT_INFO gptInfo;

    memset(&gptInfo, 0, sizeof(gptInfo));
    r = FS_GetGPTInfo("", &gptInfo);
    if (r == 0) {
        FS_X_Log("GPT partitioning info:\n");
        SEGGER_sprintf(ac, sizeof(ac), " StartSector: %lu\n",
            (U32)gptInfo.StartSector);
        FS_X_Log(ac);
        SEGGER_sprintf(ac, sizeof(ac), " NumSectors: %lu\n",
            (U32)gptInfo.NumSectors);
        FS_X_Log(ac);
        SEGGER_sprintf(ac, sizeof(ac), " NumPartitions: %u\n", gptInfo.NumPartitions);
        FS_X_Log(ac);
        SEGGER_sprintf(ac, sizeof(ac), " IsValidMain: %u\n", gptInfo.IsValidMain);
        FS_X_Log(ac);
        SEGGER_sprintf(ac, sizeof(ac), " IsValidBackup: %u\n", gptInfo.IsValidBackup);
        FS_X_Log(ac);
        FS_X_Log(" Id: ");
        SEGGER_sprintf(ac, sizeof(ac), "%02X%02X%02X%02X",
            gptInfo.abId[0], gptInfo.abId[1],
            gptInfo.abId[2], gptInfo.abId[3]);
        FS_X_Log(ac);
        FS_X_Log("-");
        SEGGER_sprintf(ac, sizeof(ac), "%02X%02X",
            gptInfo.abId[4], gptInfo.abId[5]);
        FS_X_Log(ac);
        FS_X_Log("-");
        SEGGER_sprintf(ac, sizeof(ac), "%02X%02X",
            gptInfo.abId[6], gptInfo.abId[7]);
        FS_X_Log(ac);
        FS_X_Log("-");
        SEGGER_sprintf(ac, sizeof(ac), "%02X%02X",
            gptInfo.abId[8], gptInfo.abId[9]);
        FS_X_Log(ac);
        FS_X_Log("-");
        SEGGER_sprintf(ac, sizeof(ac), "%02X%02X%02X%02X%02X%02X",
            gptInfo.abId[10], gptInfo.abId[11], gptInfo.abId[12],
            gptInfo.abId[13], gptInfo.abId[14], gptInfo.abId[15]);
        FS_X_Log(ac);
    }
}
```



```
    FS_X_Log("\n");  
  }  
}
```

4.9.4 FS_GetPartitionInfoMBR()

Description

Returns information about a MBR partition.

Prototype

```
int FS_GetPartitionInfoMBR(const char          * sVolumeName,
                          FS_PARTITION_INFO_MBR * pPartInfo,
                          U8                    PartIndex);
```

Parameters

Parameter	Description
<code>sVolumeName</code>	Name of the volume on which the partition is located.
<code>pPartInfo</code>	out Information about the partition.
<code>PartIndex</code>	Index of the partition to query.

Return value

= 0 OK, partition information read.
 ≠ 0 Error code indicating the failure reason.

Additional information

The function reads the information from the Master Boot Record (MBR) that is stored on the first sector (the sector with the index 0) of the specified volume. An error is returned if no MBR information is present on the volume. If the `Type` member of the `FS_PARTITION_INFO_MBR` structure is 0, the partition entry is not valid.

Permitted values for `PartIndex` are 0 to 3.

Example

```
#include <string.h>
#include "FS.h"

void SampleGetPartitionInfoMBR(void) {
    int          iPart;
    FS_PARTITION_INFO_MBR PartInfo;
    char         ac[100];

    //
    // Show the contents of the partition list stored in the Master
    // Boot Record. Only the valid entries are displayed.
    //
    FS_X_Log("MBR partition list:\n");
    for (iPart = 0; iPart < FS_MAX_NUM_PARTITIONS_MBR; ++iPart) {
        memset(&PartInfo, 0, sizeof(PartInfo));
        FS_GetPartitionInfoMBR("", &PartInfo, iPart);
        if (PartInfo.Type != 0) {
            SEGGER_sprintf(ac, sizeof(ac), "  Index:          %u\n", iPart);
            FS_X_Log(ac);
            SEGGER_sprintf(ac, sizeof(ac), "  StartSector:    %lu\n", PartInfo.StartSector);
            FS_X_Log(ac);
            SEGGER_sprintf(ac, sizeof(ac), "  NumSectors:    %lu\n", PartInfo.NumSectors);
            FS_X_Log(ac);
            SEGGER_sprintf(ac, sizeof(ac), "  Type:          %u\n", PartInfo.Type);
            FS_X_Log(ac);
            SEGGER_sprintf(ac, sizeof(ac), "  IsActive:     %u\n", PartInfo.IsActive);
            FS_X_Log(ac);
            SEGGER_sprintf(ac, sizeof(ac), "  FirstCylinder: %u\n", PartInfo.StartAddr.Cylinder);
            FS_X_Log(ac);
            SEGGER_sprintf(ac, sizeof(ac), "  FirstHead:     %u\n", PartInfo.StartAddr.Head);
            FS_X_Log(ac);
            SEGGER_sprintf(ac, sizeof(ac), "  FirstSector:   %u\n", PartInfo.StartAddr.Sector);
            FS_X_Log(ac);
        }
    }
}
```

```
SEGGER_sprintf(ac, sizeof(ac), "  LastCylinder: %u\n", PartInfo.EndAddr.Cylinder);
FS_X_Log(ac);
SEGGER_sprintf(ac, sizeof(ac), "  LastHead:      %u\n", PartInfo.EndAddr.Head);
FS_X_Log(ac);
SEGGER_sprintf(ac, sizeof(ac), "  LastSector:   %u\n", PartInfo.EndAddr.Sector);
FS_X_Log(ac);
FS_X_Log("\n");
    }
}
}
```

Deprecated name

FS_GetPartitionInfo

4.9.5 FS_GetPartitionInfoGPT()

Description

Returns information about a GPT partition.

Prototype

```
int FS_GetPartitionInfoGPT(const char          * sVolumeName,
                          FS_PARTITION_INFO_GPT * pPartInfo,
                          unsigned           PartIndex);
```

Parameters

Parameter	Description
<code>sVolumeName</code>	Name of the volume on which the partition is located.
<code>pPartInfo</code>	out Information about the partition.
<code>PartIndex</code>	Index of the partition to query.

Return value

= 0 OK, partition information read.
 ≠ 0 Error code indicating the failure reason.

Example

```
#include <string.h>
#include "FS.h"

void SampleGetPartitionInfoGPT(void) {
    int          iPart;
    FS_PARTITION_INFO_GPT PartInfo;
    char         ac[100];
    int          r;
    FS_GPT_INFO  gptInfo;
    int          IsEmpty;
    unsigned     i;

    //
    // Show the contents of a GUID partition table.
    // Only the valid entries are displayed.
    //
    memset(&gptInfo, 0, sizeof(gptInfo));
    r = FS_GetGPTInfo("", &gptInfo);
    if (r == 0) {
        FS_X_Log("GPT partition list:\n");
        for (iPart = 0; iPart < gptInfo.NumPartitions; ++iPart) {
            memset(&PartInfo, 0, sizeof(PartInfo));
            r = FS_GetPartitionInfoGPT("", &PartInfo, iPart);
            IsEmpty = 1;
            //
            // An empty partition entry has all the bytes in the GUID type set to 0;
            //
            for (i = 0; i < sizeof(PartInfo.abType); ++i) {
                if (PartInfo.abType[i] != 0) {
                    IsEmpty = 0;
                }
            }
            if (IsEmpty == 0) {
                SEGGER_sprintf(ac, sizeof(ac), " Index:          %u\n", iPart);
                FS_X_Log(ac);
                SEGGER_sprintf(ac, sizeof(ac), " StartSector:    %lu\n",
                    (U32)PartInfo.StartSector);
                FS_X_Log(ac);
                SEGGER_sprintf(ac, sizeof(ac), " NumSectors:    %lu\n",
                    (U32)PartInfo.NumSectors);
                FS_X_Log(ac);
                SEGGER_sprintf(ac, sizeof(ac), " Attr:          0x%08X%08X\n",
                    (U32)(PartInfo.Attributes >> 32), (U32)(PartInfo.Attributes & 0xFFFFFFFFuL));
            }
        }
    }
}
```

```

FS_X_Log(ac);
SEGGER_sprintf(ac, sizeof(ac), " Name:          %s\n", PartInfo.acName);
FS_X_Log(ac);
FS_X_Log(" Type:          ");
SEGGER_sprintf(ac, sizeof(ac), "%02X%02X%02X%02X",
    PartInfo.abType[0], PartInfo.abType[1],
    PartInfo.abType[2], PartInfo.abType[3]);
FS_X_Log(ac);
FS_X_Log("-");
SEGGER_sprintf(ac, sizeof(ac), "%02X%02X",
    PartInfo.abType[4], PartInfo.abType[5]);
FS_X_Log(ac);
FS_X_Log("-");
SEGGER_sprintf(ac, sizeof(ac), "%02X%02X",
    PartInfo.abType[6], PartInfo.abType[7]);
FS_X_Log(ac);
FS_X_Log("-");
SEGGER_sprintf(ac, sizeof(ac), "%02X%02X",
    PartInfo.abType[8], PartInfo.abType[9]);
FS_X_Log(ac);
FS_X_Log("-");
SEGGER_sprintf(ac, sizeof(ac), "%02X%02X%02X%02X%02X%02X",
    PartInfo.abType[10], PartInfo.abType[11], PartInfo.abType[12],
    PartInfo.abType[13], PartInfo.abType[14], PartInfo.abType[15]);
FS_X_Log(ac);
FS_X_Log(" Unique:          ");
SEGGER_sprintf(ac, sizeof(ac), "%02X%02X%02X%02X",
    PartInfo.abId[0], PartInfo.abId[1],
    PartInfo.abId[2], PartInfo.abId[3]);
FS_X_Log(ac);
FS_X_Log("-");
SEGGER_sprintf(ac, sizeof(ac), "%02X%02X",
    PartInfo.abId[4], PartInfo.abId[5]);
FS_X_Log(ac);
FS_X_Log("-");
SEGGER_sprintf(ac, sizeof(ac), "%02X%02X",
    PartInfo.abId[6], PartInfo.abId[7]);
FS_X_Log(ac);
FS_X_Log("-");
SEGGER_sprintf(ac, sizeof(ac), "%02X%02X",
    PartInfo.abId[8], PartInfo.abId[9]);
FS_X_Log(ac);
FS_X_Log("-");
SEGGER_sprintf(ac, sizeof(ac), "%02X%02X%02X%02X%02X%02X",
    PartInfo.abId[10], PartInfo.abId[11], PartInfo.abId[12],
    PartInfo.abId[13], PartInfo.abId[14], PartInfo.abId[15]);
FS_X_Log(ac);
FS_X_Log("\n");
FS_X_Log("\n");
    }
}
}
}

```

4.9.6 FS_GetPartitioningScheme()

Description

Returns information about how a storage device is partitioned.

Prototype

```
int FS_GetPartitioningScheme(const char * sVolumeName);
```

Parameters

Parameter	Description
<code>sVolumeName</code>	Name of the volume on which the partition is located.

Return value

- ≥ 0 OK, partitioning type. Can be one of the *Partitioning schemes* on page 178 values.
- ≠ 0 Error code indicating the failure reason.

Example

```
#include "FS.h"

void SampleGetPartitioningScheme(void) {
    int Scheme;

    Scheme = FS_GetPartitioningScheme("");
    if (Scheme >= 0) {
        switch (Scheme) {
            case FS_PARTITIONING_SCHEME_NONE:
                FS_X_Log("The storage device is not partitioned.\n");
                break;
            case FS_PARTITIONING_SCHEME_MBR:
                FS_X_Log("The storage device is partitioned via MBR.\n");
                break;
            case FS_PARTITIONING_SCHEME_GPT:
                FS_X_Log("The storage device is partitioned via GPT.\n");
                break;
            default:
                FS_X_Log("Unknown partitioning scheme.\n");
                break;
        }
    }
}
```

4.9.7 FS_GPT_INFO

Description

Information about a GUID partition table.

Type definition

```
typedef struct {
    U64  StartSector;
    U64  NumSectors;
    U16  NumPartitions;
    U8   IsValidMain;
    U8   IsValidBackup;
    U8   abId[];
} FS_GPT_INFO;
```

Structure members

Member	Description
StartSector	Index of the first logical sector that can be used for partition data (FirstUsableLBA field).
NumSectors	Index of the last logical sector that can be used for partition data (LastUsableLBA field - FirstUsableLBA field + 1).
NumPartitions	Number of partitions present on the storage device (NumberOfPartitionEntries field).
IsValidMain	Indicates if the main partition table is valid.
IsValidBackup	Indicates if the backup partition table is valid.
abId	GUID that uniquely identifies the storage device (DiskGUID field)

Additional information

The partitioning information can be obtained via `FS_GetGPTInfo()`.

4.9.8 FS_PARTITION_INFO_MBR

Description

Information about a MBR partition.

Type definition

```
typedef struct {
    U32      NumSectors;
    U32      StartSector;
    FS_CHS_ADDR StartAddr;
    FS_CHS_ADDR EndAddr;
    U8       Type;
    U8       IsActive;
} FS_PARTITION_INFO_MBR;
```

Structure members

Member	Description
NumSectors	Total number of sectors in the partition.
StartSector	Index of the first sector in the partition relative to the beginning of the storage device.
StartAddr	Address of the first sector in the partition in CHS format.
EndAddr	Address of the last sector in the partition in CHS format.
Type	Type of the partition.
IsActive	Set to 1 if the partition is bootable.

Example

For an example usage refer to `FS_GetPartitionInfoMBR()`.

Deprecated name

`FS_PARTITION_INFO_MBR`

4.9.9 FS_PARTITION_INFO_GPT

Description

Information about a GPT partition.

Type definition

```
typedef struct {
    U8    abType[];
    U8    abId[];
    U64   StartSector;
    U64   NumSectors;
    U64   Attributes;
    char  acName[];
} FS_PARTITION_INFO_GPT;
```

Structure members

Member	Description
abType	Partition type as GUID (PartitionTypeGUID field).
abId	Unique id of the partition as GUID (UniquePartitionGUID field).
StartSector	Index of the first logical sector in the partition (StartingLBA field).
NumSectors	Index of the last logical sector in the partition (EndingLBA field - StartingLBA field + 1).
Attributes	Partition attributes (Attributes field).
acName	Partition name as 0-terminated string, UTF-8 encoded (PartitionName field).

Additional information

The name of the partition returned via [acName](#) member is a 0-terminated string encoded as UTF-8. The size of this member can be configured via `FS_MAX_NUM_BYTES_PART_NAME`.

Example

For an example usage refer to `FS_GetPartitionInfoGPT()`.

4.9.10 Partitioning schemes

Description

Methods for partitioning a storage device.

Definition

```
#define FS_PARTITIONING_SCHEME_NONE    0
#define FS_PARTITIONING_SCHEME_MBR    1
#define FS_PARTITIONING_SCHEME_GPT    2
```

Symbols

Definition	Description
<code>FS_PARTITIONING_SCHEME_NONE</code>	The storage device is not partitioned.
<code>FS_PARTITIONING_SCHEME_MBR</code>	The storage device is partitioned as MBR.
<code>FS_PARTITIONING_SCHEME_GPT</code>	The storage device is partitioned as GPT.

Example

Refer to `FS_GetPartitioningScheme()` for an example usage.

4.10 File system structure checking

The functions in this section can be used by an application to check the consistency of the file system structure.

4.10.1 FS_CheckAT()

Description

Verifies the consistency of the allocation table.

Prototype

```
int FS_CheckAT(FS_CHECK_DATA * pCheckData);
```

Parameters

Parameter	Description
<code>pCheckData</code>	<code>in</code> Checking context. It cannot be NULL.

Return value

<code>= FS_CHECKDISK_RETVAL_OK</code>	No errors found or the callback returned <code>FS_CHECKDISK_ACTION_DO_NOT_REPAIR</code> .
<code>= FS_CHECKDISK_RETVAL_RETRY</code>	An error has been found. The error has been corrected since the callback function returned <code>FS_CHECKDISK_ACTION_SAVE_CLUSTERS</code> or <code>FS_CHECKDISK_ACTION_DELETE_CLUSTERS</code> . <code>FS_CheckDir()</code> has to be called again to check for the next error.
<code>= FS_CHECKDISK_RETVAL_ABORT</code>	The application requested the abort of disk checking operation through the callback returning <code>FS_CHECKDISK_ACTION_ABORT</code> .
<code>= FS_CHECKDISK_RETVAL_CONTINUE</code>	Indicates that not all the allocation table has been checked. The entire volume has to be checked again using <code>FS_CheckDir()</code> .
<code>< 0</code>	Error code indicating the failure reason.

Additional information

`FS_CheckAT()` has to be called in combination with `FS_InitCheck()` and `FS_CheckDir()` to check the consistency of the file system.

`pCheckData` has to be initialized via a call to `FS_InitCheck()`.

Example

Refer to `FS_InitCheck()` for a usage example.

4.10.2 FS_CheckDir()

Description

Verifies the consistency of a single directory.

Prototype

```
int FS_CheckDir(          FS_CHECK_DATA * pCheckData,
                      const char      * sPath);
```

Parameters

Parameter	Description
<code>pCheckData</code>	in Checking context. It cannot be NULL.
<code>sPath</code>	Path to the directory to be checked. It cannot be NULL.

Return value

<code>= FS_CHECKDISK_RETVAL_OK</code>	No errors found or the callback returned <code>FS_CHECKDISK_ACTION_DO_NOT_REPAIR</code> .
<code>= FS_CHECKDISK_RETVAL_RETRY</code>	An error has been found. The error has been corrected since the callback function returned <code>FS_CHECKDISK_ACTION_SAVE_CLUSTERS</code> or <code>FS_CHECKDISK_ACTION_DELETE_CLUSTERS</code> . <code>FS_CheckDir()</code> has to be called again to check for the next error.
<code>= FS_CHECKDISK_RETVAL_ABORT</code>	The application requested the abort of disk checking operation through the callback returning <code>FS_CHECKDISK_ACTION_ABORT</code> .
<code>= FS_CHECKDISK_RETVAL_MAX_RECURSE</code>	Maximum recursion level reached. The disk checking operation has been aborted.
<code>< 0</code>	Error code indicating the failure reason.

Additional information

`FS_CheckDir()` has to be called in combination with `FS_InitCheck()` and `FS_CheckAT()` to check the consistency of the file system.

`pCheckData` has to be initialized via a call to `FS_InitCheck()`. In order to check the entire file system structure, the application will have to call `FS_CheckDir()` with every different directory path present on the file system.

Example

Refer to `FS_InitCheck()` for a usage example.

4.10.3 FS_CheckDisk()

Description

Checks the consistency of the file system structure.

Prototype

```
int FS_CheckDisk(const char          * sVolumeName,
                 void                * pBuffer,
                 U32                  BufferSize,
                 int                   MaxRecursionLevel,
                 FS_CHECKDISK_ON_ERROR_CALLBACK * pfOnError);
```

Parameters

Parameter	Description
<code>sVolumeName</code>	Name of the volume to be checked.
<code>pBuffer</code>	Work buffer to be used for checking the allocation table.
<code>BufferSize</code>	Size of the work buffer in bytes. It cannot be NULL.
<code>MaxRecursionLevel</code>	The maximum directory depth the function is allowed to check.
<code>pfOnError</code>	Function that has to be called when an error is found. It cannot be NULL.

Return value

<code>= FS_CHECKDISK_RETVAL_OK</code>	No errors found or the callback returned <code>FS_CHECKDISK_ACTION_DO_NOT_REPAIR</code> .
<code>= FS_CHECKDISK_RETVAL_RETRY</code>	An error has been found. The error has been corrected since the callback function returned <code>FS_CHECKDISK_ACTION_SAVE_CLUSTERS</code> or <code>FS_CHECKDISK_ACTION_DELETE_CLUSTERS</code> . <code>FS_CheckDisk()</code> has to be called again to check for the next error.
<code>= FS_CHECKDISK_RETVAL_ABORT</code>	The application requested the abort of disk checking operation through the callback returning <code>FS_CHECKDISK_ACTION_ABORT</code> .
<code>= FS_CHECKDISK_RETVAL_MAX_RECURSE</code>	Maximum recursion level reached. The disk checking operation has been aborted.
<code>< 0</code>	Error code indicating the failure reason.

Additional information

This function can be used to check if any errors are present on a specific volume and, if necessary, to repair these errors. Ideally, the work buffer has to be large enough to store the usage information of all the clusters in the allocation table. `FS_CheckDisk()` uses one bit to store the usage state of a cluster. The typical size of the work buffer is about 2 KBytes. Additional iterations are performed if the work buffer is not large enough to check the whole allocation table in one step.

`FS_CheckDisk()` can detect and correct the following file system errors:

- Invalid directory entries.
- Lost clusters or cluster chains.
- Cross-linked clusters.
- Clusters are associated to a file with size of 0.
- Too few clusters are allocated to a file.
- Cluster is not marked as end-of-chain, although it should be.

The contents of a lost cluster chain is saved during the repair operation to files named FILE<FileIndex>.CHK that are stored in directories named FOUND.<DirIndex>. FileIndex is a 0-based 4-digit decimal number that is incremented by one for each cluster chain saved. DirIndex is a 0-based 3-digit decimal number that is incremented by one each time FS_CheckDisk() is called. For example the first created directory has the name FOUND.000, the second FOUND.001, and so on while the first file in the directory has the name FILE0000.CHK, the second FILE0001.CHK, and so on.

The callback function is used to notify the application about the errors found by FS_CheckDisk() during the disk checking operation. FS_CheckDisk() uses the return value of the callback function to decide if the error has to be repaired or not. For more information refer to FS_CHECKDISK_ON_ERROR_CALLBACK.

FS_CheckDisk() closes all opened files before it starts the disk checking operation. The application is not allowed to access the storage device from a different task as long as the operation is in progress.

Example

```
#include <stdio.h>
#include <stdarg.h>
#include <string.h>
#include "FS.h"

static U32 _aBuffer[1024 / 4];
static int _NumErrors;

/*****
 *
 *      _OnError
 */
static int _OnError(int ErrCode, ...) {
    va_list    ParamList;
    const char * sFormat;
    char       c;
    char       ac[256];

    (void)memset(&ParamList, 0, sizeof(ParamList));
    sFormat = FS_CheckDisk_ErrCode2Text(ErrCode);
    if (sFormat) {
        va_start(ParamList, ErrCode);
        vsprintf(ac, sFormat, ParamList);
        FS_X_Log(ac);
        FS_X_Log("\n");
    }
    if (ErrCode != FS_CHECKDISK_ERRCODE_CLUSTER_UNUSED) {
        FS_X_Log("  Do you want to repair this? (y/n/a) ");
    } else {
        FS_X_Log(" * Convert lost cluster chain into file (y)\n");
        FS_X_Log(" * Delete cluster chain (d)\n");
        FS_X_Log(" * Do not repair (n)\n");
        FS_X_Log(" * Abort (a)\n");
    }
    _NumErrors++;
    c = getchar();
    FS_X_Log("\n");
    if ((c == 'y') || (c == 'Y')) {
        return FS_CHECKDISK_ACTION_SAVE_CLUSTERS;
    } else if ((c == 'a') || (c == 'A')) {
        return FS_CHECKDISK_ACTION_ABORT;
    } else if ((c == 'd') || (c == 'D')) {
        return FS_CHECKDISK_ACTION_DELETE_CLUSTERS;
    }
    return FS_CHECKDISK_ACTION_DO_NOT_REPAIR; // Do not repair anything.
}

/*****
 *
 *      SampleCheckDisk
 */
void SampleCheckDisk(void) {
    int r;
```

```
while (1) {
    r = FS_CheckDisk("", _aBuffer, sizeof(_aBuffer), 5, _OnError);
    if (r != FS_CHECKDISK_RETVAL_RETRY) {
        break;
    }
}
if (_NumErrors == 0) {
    FS_X_Log("No errors were found.\n");
} else {
    FS_X_Log("Errors were found.\n");
}
}
```

4.10.4 FS_CheckDisk_ErrCode2Text()

Description

Returns a human-readable text description of a disk checking error code.

Prototype

```
char *FS_CheckDisk_ErrCode2Text(int ErrCode);
```

Parameters

Parameter	Description
ErrCode	Error code for which the text description has to be returned.

Return value

Text description as 0-terminated string.

Additional information

This function can be invoked inside the callback for `FS_CheckDisk()` to format the error information in human-readable format. The text description includes format specifiers for the `printf()` family of functions that can be used to show additional information about the file system error.

Refer to `FS_CheckDisk()` for more information about how to use this function.

4.10.5 FS_InitCheck()

Description

Initializes a non-blocking disk checking operation.

Prototype

```
int FS_InitCheck(      FS_CHECK_DATA          * pCheckData,
                     const char             * sVolumeName,
                     void                   * pBuffer,
                     U32                    BufferSize,
                     FS_CHECKDISK_ON_ERROR_CALLBACK * pfOnError);
```

Parameters

Parameter	Description
<code>pCheckData</code>	out Checking context. It cannot be NULL.
<code>sVolumeName</code>	Name of the volume on which the checking is performed. It cannot be NULL.
<code>pBuffer</code>	in Working buffer. It cannot be NULL.
<code>BufferSize</code>	Number of bytes in <code>pBuffer</code> .
<code>pfOnError</code>	Callback function to be invoked in case of a file system damage. It cannot be NULL.

Return value

= FS_CHECKDISK_RETVAL_OK OK, disk checking has been initialized.
 < 0 Error code indicating the failure reason.

Additional information

`FS_InitCheck()` has to be called in combination with `FS_CheckDir()` and `FS_CheckAT()` to check the consistency of the file system. These functions perform the same operation as `FS_CheckDisk()` with the difference that the access to the file system is blocked only for a limited period of time.

It is mandatory to call `FS_InitCheck()` before any call to `FS_CheckDir()` or `FS_CheckAT()`. The purpose of `FS_InitCheck()` is to prepare the checking context `pCheckData` for the operation. This context must be passed to `FS_CheckDir()` and `FS_CheckAT()`.

The parameters `sVolumeName`, `pBuffer`, `BufferSize` and `pfOnError` have the same meaning as the corresponding parameters of `FS_CheckDisk()`. Refer to `FS_CheckDisk()` for more information about the usage of these parameters.

In a typical usage the application calls `FS_InitCheck()` once followed by multiple calls to `FS_CheckDir()` and `FS_CheckAT()`. In addition, each time `FS_CheckDir()` and `FS_CheckAT()` find and correct an error `FS_InitCheck()` has to be called again to re-initialize the operation.

Example

The following example demonstrates how the consistency of the file system structure can be checked while the application performs normal file system operations.

```
#include <stdarg.h>
#include <stdio.h>
#include <string.h>
#include "FS.h"

#define VOLUME_NAME      ""
#define MAX_RECURSION    5

static U32 _aBuffer[1024 / 4];
```

```

static int _NumErrors;

/*****
 *
 *      _IsSystemDir
 */
static int _IsSystemDir(const char * sDirName) {
    if (((*sDirName == '.') && (*(sDirName + 1) == '\0'))) {
        return 1;
    }
    if (((*sDirName == '.') && (*(sDirName + 1) == '.') && (*(sDirName + 2) == '\0'))) {
        return 1;
    }
    return 0;
}

/*****
 *
 *      _cbOnError
 */
static int _cbOnError(int ErrCode, ...) {
    va_list      ParamList;
    const char * sFormat;
    int          c;
    char         ac[1000];

    //lint --e{438} -esym(530, ParamList)
    sFormat = FS_CheckDisk_ErrCode2Text(ErrCode);
    if (sFormat) {
        va_start(ParamList, ErrCode);
        SEGGER_vsnprintf(ac, sizeof(ac), sFormat, ParamList);
        va_end(ParamList);
        FS_X_Log(ac);
        FS_X_Log("\n");
    }
    if (ErrCode != FS_CHECKDISK_ERRCODE_CLUSTER_UNUSED) {
        FS_X_Log(" Do you want to repair this error? (y/n/a) ");
    } else {
        FS_X_Log(" * Convert lost cluster chain into file (y)\n");
        FS_X_Log(" * Delete cluster chain (d)\n");
        FS_X_Log(" * Do not repair (n)\n");
        FS_X_Log(" * Abort (a)\n");
    }
}
++_NumErrors;
c = getchar();
FS_X_Log("\n");
if ((c == 'y') || (c == 'Y')) {
    return FS_CHECKDISK_ACTION_SAVE_CLUSTERS;
} else if ((c == 'a') || (c == 'A')) {
    return FS_CHECKDISK_ACTION_ABORT;
} else if ((c == 'd') || (c == 'D')) {
    return FS_CHECKDISK_ACTION_DELETE_CLUSTERS;
}
return FS_CHECKDISK_ACTION_DO_NOT_REPAIR;
}

/*****
 *
 *      _CheckDir
 *
 *      Function description
 *      Checks the consistency of a directory tree.
 *
 *      Notes
 *      (1) This function calls itself recursively.
 */
static int _CheckDir(FS_CHECK_DATA * pCheckData, char * sDirPath,
                    unsigned SizeOfDirPath, int MaxRecursionLevel) {
    int          r;
    int          Result;
    FS_FIND_DATA FindData;
    char         acDirName[32];
    unsigned     LenPath;
    unsigned     LenName;
    char         * p;
    char         * pEnd;

```

```

unsigned      NumBytes;

r = FS_CheckDir(pCheckData, sDirPath);
if (r == FS_CHECKDISK_RETVAL_OK) {
    //
    // Search for subdirectories and descend into them.
    //
    memset(&FindData, 0, sizeof(FindData));
    Result = FS_FindFirstFile(&FindData, sDirPath, acDirName, sizeof(acDirName));
    if (Result == 0) {
        while (1) {
            //
            // Descend into any directory other than "." and "..".
            //
            if (FindData.Attributes & FS_ATTR_DIRECTORY) {
                if (!_IsSystemDir(FindData.sFileName) == 0) {
                    if (MaxRecursionLevel == 0) {
                        r = FS_CHECKDISK_RETVAL_MAX_RECURSE;           // Error, deepest directory
                                                                    // level reached.

                        break;
                    }
                    //
                    // Create the path to the directory.
                    //
                    LenPath = strlen(sDirPath);
                    if (LenPath >= (SizeOfDirPath - 1)) {
                        r = FS_ERRCODE_BUFFER_TOO_SMALL;             // Error, cannot create path
                                                                    // to directory.

                        break;
                    }
                    NumBytes = SizeOfDirPath - LenPath;
                    LenName = strlen(FindData.sFileName);
                    if ((LenName + 1 + 1) >= NumBytes) {
                        r = FS_ERRCODE_BUFFER_TOO_SMALL;             // Error, cannot create path
                                                                    // to directory.

                        break;
                    }
                    pEnd = sDirPath + LenPath;
                    p = pEnd;
                    strcpy(p, FindData.sFileName);                   // Add the directory name.
                    p += LenName;
                    *p++ = FS_DIRECTORY_DELIMITER;                   // Separate the path from
                                                                    // directory name.

                    *p = '\0';
                    r = _CheckDir(pCheckData, sDirPath, SizeOfDirPath, MaxRecursionLevel - 1);
                    *pEnd = '\0';                                     // Restore the path to parent
                                                                    // directory.

                    if (r != FS_CHECKDISK_RETVAL_OK) {
                        break;
                    }
                }
            }
            Result = FS_FindNextFile(&FindData);
            if (Result == 0) {
                break;                                             // End of directory reached
                                                                    // or error.
            }
        }
    }
}
if (r == FS_CHECKDISK_RETVAL_SKIP) {
    r = FS_CHECKDISK_RETVAL_OK;                                   // Make sure that we return

    // the same value as FS_CheckDisk()
}
return r;
}

/*****
*
*      _CheckDisk
*
*      Function description
*      Checks the consistency of the file system.
*/
static int _CheckDisk(void) {

```

```

int          r;
char         acDirName[FS_MAX_PATH];
FS_CHECK_DATA CheckData;

memset(&CheckData, 0, sizeof(CheckData));
for (;;) {
    //
    // Initialize the operation.
    //
    r = FS_InitCheck(&CheckData, VOLUME_NAME, _aBuffer, sizeof(_aBuffer), _cbOnError);
    if (r != 0) {
        break; // Error, could not initialize
              // the operation.
    }
    for (;;) {
        memset(acDirName, 0, sizeof(acDirName)); // Begin the checking with the
                                                // root directory.

        strncpy(acDirName, VOLUME_NAME, sizeof(acDirName) - 1);
        //
        // Check the directory structure.
        //
        r = _CheckDir(&CheckData, acDirName, sizeof(acDirName), MAX_RECURSION);
        if (r != FS_CHECKDISK_RETVAL_OK) {
            break; // An error occurred.
        }
        //
        // Check the allocation table.
        //
        r = FS_CheckAT(&CheckData);
        if (r != FS_CHECKDISK_RETVAL_CONTINUE) {
            break; // No more checks are required
                // or an error was found and corrected.
        }
    }
    if (r != FS_CHECKDISK_RETVAL_RETRY) {
        break; // Operation completed.
    }
}
return r;
}

/*****
 *
 *      SampleCheckDiskBG
 */
void SampleCheckDiskBG(void) {
    FS_CHECK_DATA CheckData;
    FS_CHECK_DATA CheckDataOld;
    int          r;

    //
    // Initialize the check context.
    //
    memset(&CheckDataOld, 0, sizeof(CheckDataOld));
    memset(&CheckData, 0, sizeof(CheckData));
    for (;;) {
        //
        // Wait for a file system change.
        //
        for (;;) {
            r = FS_InitCheck(&CheckData, VOLUME_NAME, _aBuffer, sizeof(_aBuffer), _cbOnError);
            if (r == 0) {
                r = memcmp(&CheckData, &CheckDataOld, sizeof(FS_CHECK_DATA));
                if (r != 0) {
                    break;
                }
            }
            //
            // TBD: Delay execution using a RTOS function.
            //
        }
        _NumErrors = 0;
        //
        // Check and correct file system errors.
        //

```

```
r = _CheckDisk();
if (r != 0) {
    FS_X_Log("Disk checking operation failed.\n");
} else {
    if (_NumErrors == 0) {
        FS_X_Log("File system structure is consistent.\n");
    }
}
memcpy(&CheckDataOld, &CheckData, sizeof(FS_CHECK_DATA));
}
```

4.11 File system extended functions

This section describes API functions that do not fall in any other category. It includes functions that operate on volumes, utility functions as well as functions for locking the file system against concurrent access from different tasks.

4.11.1 FS_ConfigEOFErrorSuppression()

Description

Enables / disables the reporting of end-of-file condition as error.

Prototype

```
void FS_ConfigEOFErrorSuppression(int OnOff);
```

Parameters

Parameter	Description
OnOff	Activation status of the option. <ul style="list-style-type: none">• 0 EOF is reported as error.• 1 EOF is not reported as error.

Additional information

The end-of-file indicator of a file handle is set to 1 as soon as the application tries to read more bytes than available in the file. This function controls if an error is reported via `FS_FError()` when the end-of-file indicator is set for a file handle. The default is to report the end-of-file condition as error. The configuration has effect on all the opened file handles.

This function is available only when the file system is built with `FS_SUPPRESS_EOF_ERROR` set to 1.

4.11.2 FS_ConfigPOSIXSupport()

Description

Enables / disables support for the POSIX-like behavior.

Prototype

```
void FS_ConfigPOSIXSupport(int OnOff);
```

Parameters

Parameter	Description
OnOff	Activation status of the option. <ul style="list-style-type: none">• 0 POSIX behavior is disabled.• 1 POSIX behavior is enabled.

Additional information

The end-of-file indicator of a file handle is set to 1 as soon as the application tries to read more bytes than available in the file. This function controls if an error is reported via `FS_FError()` when the end-of-file indicator is set for a file handle. The default is to report the end-of-file condition as error. The configuration has effect on all the opened file handles.

4.11.3 FS_ConfigWriteVerification()

Description

Enables / disables the verification of the written data.

Prototype

```
void FS_ConfigWriteVerification(int OnOff);
```

Parameters

Parameter	Description
OnOff	Activation status of the option. <ul style="list-style-type: none">• 0 Verification is disabled.• 1 Verification is enabled.

Additional information

If enabled, this feature requests the file system to check that the data has been written correctly to storage device. This operation is performed by reading back and comparing the read with the written data. The verification is performed one logical sector at a time. A sector buffer is allocated from the memory pool for this operation.

4.11.4 FS_FileTimeToTimeStamp()

Description

Converts a broken-down date and time specification to a timestamp.

Prototype

```
void FS_FileTimeToTimeStamp(const FS_FILETIME * pFileTime,
                           U32                * pTimeStamp);
```

Parameters

Parameter	Description
<code>pFileTime</code>	in Broken-down date and time to be converted. It cannot be NULL.
<code>pTimeStamp</code>	out Converted timestamp. It cannot be NULL.

Additional information

This function can be used to convert a broken-down date and time specification to a timestamp used by the file system. The converted timestamp can be directly passed to `FS_SetFileTime()` or `FS_SetFileTimeEx()` to change the timestamps of files and directories.

For a description of the timestamp format refer to `FS_GetFileTime()`.

Example

```
#include "FS.h"

void SampleSetFileTime(void) {
    U32    TimeStamp;
    FS_FILETIME FileTime;

    FileTime.Year    = 2005;
    FileTime.Month   = 03;
    FileTime.Day     = 26;
    FileTime.Hour    = 10;
    FileTime.Minute  = 56;
    FileTime.Second  = 14;
    FS_FileTimeToTimeStamp (&FileTime, &TimeStamp);
    FS_SetFileTime("Test.txt", TimeStamp);
}
```

4.11.5 FS_FreeSectors()

Description

Informs the device driver about unused sectors.

Prototype

```
int FS_FreeSectors(const char * sVolumeName);
```

Parameters

Parameter	Description
<code>sVolumeName</code>	Name of the volume on which to perform the operation.

Return value

= 0 OK, sectors have been freed.
≠ 0 Error code indicating the failure reason.

Additional information

The function visits each entry of the allocation table and checks if the cluster is used to store data. If the cluster is free, informs the storage layer that the sectors assigned to the cluster do not store valid data. This information is used by the NAND and NOR device drivers to optimize the internal wear-leveling process.

`FS_FreeSectors()` is available only when the support for the free sector operation is enabled. The support for the free sector operation can be enabled or disabled via `FS_SUPPORT_FREE_SECTOR`.

Example

```
#include "FS.h"

void SampleFreeSectors(void) {
    FS_FreeSectors("nand:0:");
}
```

4.11.6 FS_GetAutoMount()

Description

Returns information about how a volume is automatically mounted.

Prototype

```
int FS_GetAutoMount(const char * sVolumeName);
```

Parameters

Parameter	Description
<code>sVolumeName</code>	Name of the volume to be queried.

Return value

= 0 Volume is not mounted automatically.
= FS_MOUNT_RO Volume is mounted automatically in read only mode.
= FS_MOUNT_RW Volume is mounted automatically in read/write mode.
< 0 Error code indicating the failure reason. Refer to `FS_ErrorNo2Text()`.

Additional information

After the initialization of the file system all the volumes are configured to be automatically mounted as read/write at the first access to the file system. The type of mount operation can be configured via `FS_SetAutoMount()`.

4.11.7 FS_GetFileId()

Description

Calculates a value that uniquely identifies a file.

Prototype

```
int FS_GetFileId(const char * sFileName,  
                U8      * pId);
```

Parameters

Parameter	Description
<code>sFileName</code>	Name of the file for which to calculate the id.
<code>pId</code>	A 16-byte array where the id is stored.

Return value

= 0 Id returned OK.
≠ 0 Error code indicating the failure reason.

Additional information

The calculated value is a combination of the sector number that stores the directory entry assigned to file combined with the index of the directory index. Typically used by USB MTP component of SEGGER emUSB-Device to create an unique object id to the file.

4.11.8 FS_GetFileWriteMode()

Description

Returns the write mode.

Prototype

```
FS_WRITEMODE FS_GetFileWriteMode(void);
```

Return value

WriteMode Specifies how to write to file:

- `FS_WRITEMODE_SAFE` Updates the allocation table and the directory entry at each write to file operation.
- `FS_WRITEMODE_MEDIUM` Updates the allocation table at each write to file operation.
- `FS_WRITEMODE_FAST` The allocation table and directory entry are updated when the file is closed.
- `FS_WRITEMODE_UNKNOWN` An error occurred.

Additional information

This function can be used to query the write mode configured for the entire file system. The write mode for the entire file system can be configured via `FS_SetFileWriteMode()`. The write mode is set by default to `FS_WRITEMODE_SAFE` when the file system is initialized.

Refer to `FS_SetFileWriteMode()` for detailed information about the different write modes.

4.11.9 FS_GetFileWriteModeEx()

Description

Returns the write mode configured for a specified volume.

Prototype

```
FS_WRITEMODE FS_GetFileWriteModeEx(const char * sVolumeName);
```

Parameters

Parameter	Description
<code>sVolumeName</code>	Identifies the volume that have to be queried.

Return value

WriteMode Specifies how to write to file:

- `FS_WRITEMODE_SAFE` Updates the allocation table and the directory entry at each write to file operation.
- `FS_WRITEMODE_MEDIUM` Updates the allocation table at each write to file operation.
- `FS_WRITEMODE_FAST` The allocation table and directory entry are updated when the file is closed.
- `FS_WRITEMODE_UNKNOWN` An error occurred.

Additional information

This function can be used to query the write mode configured for the specified volume. The write mode of the volume can be configured via `FS_SetFileWriteModeEx()`. If the write mode is not explicitly configured by the application for the volume via `FS_SetFileWriteModeEx()` then the write mode configured for the entire file system is returned. The write mode for the entire file system can be configured via `FS_SetFileWriteMode()`. The write mode is set by default to `FS_WRITEMODE_SAFE` when the file system is initialized.

Refer to `FS_SetFileWriteMode()` for detailed information about the different write modes.

4.11.10 FS_GetFSType()

Description

Returns the type of file system assigned to volume.

Prototype

```
int FS_GetFSType(const char * sVolumeName);
```

Parameters

Parameter	Description
<code>sVolumeName</code>	Name of the volume to be queried. It cannot be NULL.

Return value

≥ 0 File system type (FS_FAT or FS_EFS)
 < 0 Error code indicating the failure reason.

Additional information

This function is optional and available only when both the FAT and the EFS file system are enabled in the file system, that is the FS_SUPPORT_FAT and FS_SUPPORT_EFS configuration defines are both set to 1 (multiple-volume configuration).

Example

```
#include "FS.h"

void SampleGetFSType(void) {
    int FSType;

    #if FS_SUPPORT_MULTIPLE_FS
        FSType = FS_GetFSType("");
    #else
        FSType = FS_FAT;
    #endif
    FS_X_Log("File system type: ");
    switch (FSType) {
        case FS_FAT:
            FS_X_Log("FAT");
            break;
        case FS_EFS:
            FS_X_Log("EFS");
            break;
        default:
            FS_X_Log("<unknown>");
            break;
    }
    FS_X_Log("\n");
}
```

4.11.11 FS_GetMaxSectorSize()

Description

Queries the maximum configured logical sector size.

Prototype

```
U32 FS_GetMaxSectorSize(void);
```

Return value

Maximum logical sector size in bytes.

Additional information

Default value of the maximum logical sector size is 512 bytes. Refer to `FS_SetMaxSectorSize()` for more information about the maximum logical sector size.

Example

```
#include "FS.h"

void SampleGetMaxSectorSize(void) {
    U32 MaxSectorSize;

    MaxSectorSize = FS_GetMaxSectorSize();
}
```

4.11.12 FS_GetMemInfo()

Description

Returns information about the memory management.

Prototype

```
int FS_GetMemInfo(FS_MEM_INFO * pMemInfo);
```

Parameters

Parameter	Description
<code>pMemInfo</code>	<code>out</code> Returned information.

Return value

- = 0 OK, information returned.
- ≠ 0 Error code indicating the failure reason.

Additional information

The application can use this function to obtain information about the memory management such as number of bytes allocated by the file system, type of memory management used, etc.

4.11.13 FS_GetMountType()

Description

Returns information about how a volume is mounted.

Prototype

```
int FS_GetMountType(const char * sVolumeName);
```

Parameters

Parameter	Description
<code>sVolumeName</code>	Name of the volume to be queried.

Return value

= 0 Volume is not mounted.
 = FS_MOUNT_RO Volume is mounted read only.
 = FS_MOUNT_RW Volume is mounted read/write.
 < 0 Error code indicating the failure reason. Refer to `FS_ErrorNo2Text()`.

Additional information

`sVolumeName` is the name of a volume that already exists. If the volume name is not known to file system then an error is returned. Alternatively, the application can call `FS_IsVolumeMounted()` if the information about how the volume is actually mounted is not important. After the file system initialization all volumes are in unmounted state.

Example

```
#include <stdio.h>
#include "FS.h"

void SampleGetMountType(void) {
    int r;
    const char * sMountType;
    char ac[100];

    r = FS_GetMountType("");
    switch (r) {
        case 0:
            sMountType = "not mounted";
            break;
        case FS_MOUNT_RO:
            sMountType = "read only";
            break;
        case FS_MOUNT_RW:
            sMountType = "read/write";
            break;
        default:
            sMountType = FS_ErrorNo2Text(r);
            break;
    }
    SEGGER_sprintf(ac, sizeof(ac), "Mount type: %s\n", sMountType);
    FS_X_Log(ac);
}
```

4.11.14 FS_GetNumFilesOpen()

Description

Queries the number of opened file handles.

Prototype

```
int FS_GetNumFilesOpen(void);
```

Return value

Total number of file handles that are open.

Additional information

This function counts the number of file handles that were opened by the application via `FS_FOpen()` or `FS_FOpenEx()` and that were not closed yet via `FS_FClose()`.

The returned value is not the actual number of files opened because the same file can be opened by an application more than one time. For example, `FS_GetNumFilesOpen()` returns 2 if the same file is opened by the application twice.

Example

```
#include "FS.h"

void SampleGetNumFilesOpen(void) {
    FS_FILE * pFile1;
    FS_FILE * pFile2;
    int      NumFileHandles;

    FS_Init();
    //
    // The number of opened files is 0 at this stage.
    //
    NumFileHandles = FS_GetNumFilesOpen();
    //
    // Open the first file.
    //
    pFile1 = FS_FOpen("File1.txt", "w");
    //
    // The number of opened files is 1 at this stage.
    //
    NumFileHandles = FS_GetNumFilesOpen();
    //
    // Open the second file.
    //
    pFile2 = FS_FOpen("File2.txt", "w");
    //
    // The number of opened files is 2 at this stage.
    //
    NumFileHandles = FS_GetNumFilesOpen();
    //
    // Close first file.
    //
    FS_FClose(pFile1);
    //
    // The number of opened files is 1 at this stage.
    //
    NumFileHandles = FS_GetNumFilesOpen();
    //
    // Close second file.
    //
    FS_FClose(pFile2);
    //
    // The number of opened files is 0 at this stage.
    //
    NumFileHandles = FS_GetNumFilesOpen();
}
```

4.11.15 FS_GetNumFilesOpenEx()

Description

Queries the number of opened file handles on a volume.

Prototype

```
int FS_GetNumFilesOpenEx(const char * sVolumeName);
```

Parameters

Parameter	Description
<code>sVolumeName</code>	Name of the volume (0-terminated string). NULL is permitted.

Return value

- ≥ 0 Total number of file handles that are open on the volume.
- < 0 Error code indicating the failure reason.

Additional information

This function counts the number of file handles that were opened by the application via `FS_FOpen()` or `FS_FOpenEx()` and that were not closed yet via `FS_FClose()` on a specified volume.

The returned value is not the actual number of files opened because the same file can be opened by an application more than one time. For example, `FS_GetNumFilesOpenEx()` returns 2 if the same file is opened by the application twice.

`FS_GetNumFilesOpenEx()` works in the same way as `FS_GetNumFilesOpen()` if `sVolumeName` is set to NULL.

4.11.16 FS_GetNumVolumes()

Description

Queries the number of configured volumes.

Prototype

```
int FS_GetNumVolumes(void);
```

Return value

Number of volumes.

Additional information

This function can be used to check how many volumes are configured in the file system. Each call to `FS_AddDevice()` creates a separate volume. Calling `FS_AddPhysDevice()` does not create a volume. The maximum number of volumes is limited only by available memory.

`FS_GetNumVolumes()` can be used together with `FS_GetVolumeName()` to list the names of all configured volumes.

Example

```
#include "FS.h"

void SampleGetVolumeName(void) {
    int NumVolumes;
    int iVolume;
    int BufferSize;
    int NumBytesStored;
    char acVolumeName[32];

    BufferSize = sizeof(acVolumeName);
    NumVolumes = FS_GetNumVolumes();
    FS_X_Log("Available volumes:\n");
    for (iVolume = 0; iVolume < NumVolumes; iVolume++) {
        NumBytesStored = FS_GetVolumeName(iVolume, acVolumeName, BufferSize);
        if (NumBytesStored < BufferSize) {
            FS_X_Log(" ");
            FS_X_Log(acVolumeName);
            FS_X_Log("\n");
        }
    }
}
```

4.11.17 FS_GetVolumeAlias()

Description

Returns the alternative name of a volume.

Prototype

```
char *FS_GetVolumeAlias(const char * sVolumeName);
```

Parameters

Parameter	Description
<code>sVolumeName</code>	in Name of the volume to be queried. It cannot be set to NULL.

Return value

= NULL No volume alias configured or an error occurred.

≠ NULL Configured volume alias.

Additional information

This function is optional. It can be used by an application to obtain the alternative name of a volume if configured. For more information about the volume alias refer to `FS_SetVolumeAlias()`.

This function is available only when `FS_SUPPORT_VOLUME_ALIAS` is set to 1.

The alias of a volume can also be queried either via `FS_GetVolumeInfo()` or `FS_GetVolumeInfoEx()`. The `sAlias` member of the `FS_DISK_INFO` structure stores the configured alias.

4.11.18 FS_GetVolumeFreeSpace()

Description

Returns the free space available on a volume.

Prototype

```
U32 FS_GetVolumeFreeSpace(const char * sVolumeName);
```

Parameters

Parameter	Description
<code>sVolumeName</code>	Name of the volume to be checked.

Return value

≠ 0 Number of bytes available on the volume.
 = 0 An error occurred.

Additional information

This function returns the free space available to application to store files and directories.

A free space larger than four Gbytes is reported as `0xFFFFFFFF` because this is the maximum value that can be represented in an unsigned 32-bit integer. The function `FS_GetVolumeFreeSpaceKB()` can be used instead if the available free space is larger than four Gbytes.

`FS_GetVolumeFreeSpace()` can still be reliably used if the application does not need to know if there is more than four GBytes of free space available.

Example

```
#include <stdio.h>
#include "FS.h"

void SampleGetVolumeFreeSpace(void) {
    U32 NumBytes;
    char ac[100];

    NumBytes = FS_GetVolumeFreeSpace("");
    if (NumBytes < 0x8000) {
        SEGGER_sprintf(ac, sizeof(ac), "Free space: %lu Kbytes\n", NumBytes);
    } else {
        NumBytes >>= 10;
        SEGGER_sprintf(ac, sizeof(ac), "Free space: %lu Mbytes\n", NumBytes);
    }
    FS_X_Log(ac);
}
```

4.11.19 FS_GetVolumeFreeSpaceFirst()

Description

Initiates the search for free space.

Prototype

```
int FS_GetVolumeFreeSpaceFirst(    FS_FREE_SPACE_DATA * pFSD,
                                  const char      * sVolumeName,
                                  void             * pBuffer,
                                  int              SizeOfBuffer);
```

Parameters

Parameter	Description
<code>pFSD</code>	Context of the free space search.
<code>sVolumeName</code>	Name of the volume to search on.
<code>pBuffer</code>	Work buffer.
<code>SizeOfBuffer</code>	Size of the work buffer in bytes.

Return value

- = 1 OK, the entire allocation table has been searched.
- = 0 OK, search is not completed.
- < 0 Error code indicating the failure reason.

Additional information

`FS_GetVolumeFreeSpaceFirst()` together with `FS_GetVolumeFreeSpaceNext()` can be used to calculate the amount of available free space on a volume. This pair of functions implement the same functionality as `FS_GetVolumeFreeSpace()` with the difference that they block the access to the file system for a very short time.

Typically, `FS_GetVolumeFreeSpace()` uses the information stored to the FSInfo sector of a FAT file system or to the Status sector of an EFS file system to get the number of free clusters on the volume. If this information is not available then `FS_GetVolumeFreeSpace()` calculates the free space by reading and evaluating the entire allocation table. The size of the allocation table depends on the size of the volume with sizes of a few tens of Mbytes for a volume of 4 Gbytes or larger. Reading such amount of data can take a relatively long time to complete during which the application is not able to access the file system. `FS_GetVolumeFreeSpaceFirst()` and `FS_GetVolumeFreeSpaceNext()` can be used in such cases by calculating the available free space while the application is performing other file system accesses.

`FS_GetVolumeFreeSpaceFirst()` is used by the application to initiate the search process followed by one or more calls to `FS_GetVolumeFreeSpaceNext()`. The free space is returned in the `NumClustersFree` member of `pFSD`. The cluster size can be determined by calling `FS_GetVolumeInfoEx()` with the `Flags` parameter set to 0.

The specified work buffer is used by the file system for the read operations only when `FS_SUPPORT_SECTOR_BUFFER_BURST` is set to 1. The file system is able to use the work buffer for burst operations only if `pBuffer` is aligned according to the value configured via `FS_DRIVER_ALIGNMENT`.

Example

```
#include <stdio.h>
#include "FS.h"

void SampleGetVolumeFreeSpace(void) {
    char      ac[100];
    FS_FREE_SPACE_DATA fsd;
```

```

int          r;
FS_DISK_INFO VolumeInfo;
U32         BytesPerCluster;
U32         NumKBytesFree;

r = FS_GetVolumeFreeSpaceFirst(&fsd, "", NULL, 0);
if (r < 0) {
    SEGGER_sprintf(ac, sizeof(ac), "Could not initiate searching (%s)\n",
        FS_ErrorNo2Text(r));
    FS_X_Log(ac);
} else {
    if (r == 0) {
        for (;;) {
            r = FS_GetVolumeFreeSpaceNext(&fsd);
            if (r < 0) {
                SEGGER_sprintf(ac, sizeof(ac), "Could not continue searching (%s)\n",
                    FS_ErrorNo2Text(r));
                FS_X_Log(ac);
                break;
            }
            if (r == 1) {
                // End of allocation table reached.
                break;
            }
        }
    }
}
FS_GetVolumeInfoEx("", &VolumeInfo, 0);
BytesPerCluster = (VolumeInfo.BytesPerSector * VolumeInfo.SectorsPerCluster);
NumKBytesFree   = fsd.NumClustersFree * (BytesPerCluster >> 10);
SEGGER_sprintf(ac, sizeof(ac), "Free space: %lu Kbytes\n", NumKBytesFree);
FS_X_Log(ac);
}

```

4.11.20 FS_GetVolumeFreeSpaceKB()

Description

Returns the free space available on a volume.

Prototype

```
U32 FS_GetVolumeFreeSpaceKB(const char * sVolumeName);
```

Parameters

Parameter	Description
<code>sVolumeName</code>	Name of the volume to be checked.

Return value

≠ 0 The space available on the volume in Kbytes.
= 0 An error occurred.

Additional information

This function returns the free space available to application to store files and directories.

Example

```
#include <stdio.h>
#include "FS.h"

void SampleGetVolumeFreeSpaceKB(void) {
    U32 NumKBytes;
    char ac[100];

    NumKBytes = FS_GetVolumeFreeSpaceKB("");
    SEGGER_sprintf(ac, sizeof(ac), "Free space: %lu Kbytes\n", NumKBytes);
    FS_X_Log(ac);
}
```

4.11.21 FS_GetVolumeFreeSpaceNext()

Description

Continues the search for free space.

Prototype

```
int FS_GetVolumeFreeSpaceNext(FS_FREE_SPACE_DATA * pFSD);
```

Parameters

Parameter	Description
<code>pFSD</code>	Context of the free space search.

Return value

- = 1 OK, the entire allocation table has been searched.
- = 0 OK, search is not completed.
- < 0 Error code indicating the failure reason.

Additional information

`pFSD` has to be initialized via a call to `FS_GetVolumeFreeSpaceFirst()`. One or more calls to `FS_GetVolumeFreeSpaceNext()` are required in order to determine the available free space. For more information refer to `FS_GetVolumeFreeSpaceFirst()`.

Example

Refer to `FS_GetVolumeFreeSpaceFirst()` for an example usage.

4.11.22 FS_GetVolumeInfo()

Description

Returns information about a volume.

Prototype

```
int FS_GetVolumeInfo(const char * sVolumeName,
                    FS_DISK_INFO * pInfo);
```

Parameters

Parameter	Description
<code>sVolumeName</code>	Name of the volume to query. It cannot be NULL.
<code>pInfo</code>	out Volume information. It cannot be NULL.

Return value

= 0 OK, information returned.
 ≠ 0 Error code indicating the failure reason.

Additional information

This function collects the information about the volume such as volume size, available free space, format type, etc.

Example

```
#include <stdio.h>
#include <string.h>
#include "FS.h"

void SampleGetVolumeInfo(void) {
    FS_DISK_INFO  VolumeInfo;
    int           r;
    char          ac[100];
    const char    * sFSType;

    memset(&VolumeInfo, 0, sizeof(VolumeInfo));
    r = FS_GetVolumeInfo("", &VolumeInfo);
    if (r == 0) {
        SEGGER_sprintf(ac, sizeof(ac), "Number of total clusters:      %lu\n",
                       VolumeInfo.NumTotalClusters);
        FS_X_Log(ac);
        SEGGER_sprintf(ac, sizeof(ac), "Number of free clusters:      %lu\n",
                       VolumeInfo.NumFreeClusters);
        FS_X_Log(ac);
        SEGGER_sprintf(ac, sizeof(ac), "Sectors per cluster:         %d\n",
                       VolumeInfo.SectorsPerCluster);
        FS_X_Log(ac);
        SEGGER_sprintf(ac, sizeof(ac), "Bytes per sector:            %d\n",
                       VolumeInfo.BytesPerSector);
        FS_X_Log(ac);
        SEGGER_sprintf(ac, sizeof(ac), "Number of root directory entries: %d\n",
                       VolumeInfo.NumRootDirEntries);
        FS_X_Log(ac);
        switch (VolumeInfo.FSType) {
            case FS_TYPE_FAT12:
                sFSType = "FAT12";
                break;
            case FS_TYPE_FAT16:
                sFSType = "FAT16";
                break;
            case FS_TYPE_FAT32:
                sFSType = "FAT32";
                break;
            case FS_TYPE_EFS:
                sFSType = "EFS";
                break;
        }
    }
}
```

```
        break;
    default:
        sFSType = "<Unknown>";
        break;
    }
    SEGGER_sprintf(ac, sizeof(ac), "File system type:           %s\n",
        sFSType);
    FS_X_Log(ac);
    SEGGER_sprintf(ac, sizeof(ac), "Formatted acc. to SD spec.:   %s\n",
        VolumeInfo.IsSDFormatted ? "Yes" : "No");
    FS_X_Log(ac);
    SEGGER_sprintf(ac, sizeof(ac), "Has been modified:           %s\n",
        VolumeInfo.IsDirty ? "Yes" : "No");
    FS_X_Log(ac);
}
}
```

4.11.23 FS_GetVolumeInfoEx()

Description

Returns information about a volume. Identical to `FS_GetVolumeInfo` except it gives the application more control about which type of information should be returned.

Prototype

```
int FS_GetVolumeInfoEx(const char      * sVolumeName,
                      FS_DISK_INFO * pInfo,
                      int             Flags);
```

Parameters

Parameter	Description
<code>sVolumeName</code>	The volume name.
<code>pInfo</code>	<code>out</code> Volume information.
<code>Flags</code>	Bit mask that controls what type of information the function returns. It is an or-combination of <code>FS_DISKINFO_FLAG_...</code> defines.

Return value

= 0 OK, information returned.
 ≠ 0 Error code indicating the failure reason.

Additional information

This function collects the information about the volume such as volume size, available free space, format type, etc. The kind of information is actually returned can be controlled via the `Flags` parameter.

Example

```
#include <stdio.h>
#include <string.h>
#include "FS.h"

void SampleGetVolumeInfoEx(void) {
    FS_DISK_INFO  VolumeInfo;
    int           r;
    char          ac[100];
    const char    * sFSType;

    memset(&VolumeInfo, 0, sizeof(VolumeInfo));
    //
    // Return also the available free space.
    //
    r = FS_GetVolumeInfoEx("", &VolumeInfo, FS_DISKINFO_FLAG_FREE_SPACE);
    if (r == 0) {
        SEGGER_sprintf(ac, sizeof(ac), "Number of total clusters:      %lu\n",
            VolumeInfo.NumTotalClusters);
        FS_X_Log(ac);
        SEGGER_sprintf(ac, sizeof(ac), "Number of free clusters:      %lu\n",
            VolumeInfo.NumFreeClusters);
        FS_X_Log(ac);
        SEGGER_sprintf(ac, sizeof(ac), "Sectors per cluster:         %d\n",
            VolumeInfo.SectorsPerCluster);
        FS_X_Log(ac);
        SEGGER_sprintf(ac, sizeof(ac), "Bytes per sector:            %d\n",
            VolumeInfo.BytesPerSector);
        FS_X_Log(ac);
        SEGGER_sprintf(ac, sizeof(ac), "Number of root directory entries: %d\n",
            VolumeInfo.NumRootDirEntries);
        FS_X_Log(ac);
        switch (VolumeInfo.FSType) {
```



```
case FS_TYPE_FAT12:
    sFSType = "FAT12";
    break;
case FS_TYPE_FAT16:
    sFSType = "FAT16";
    break;
case FS_TYPE_FAT32:
    sFSType = "FAT32";
    break;
case FS_TYPE_EFS:
    sFSType = "EFS";
    break;
default:
    sFSType = "<Unknown>";
    break;
}
SEGGER_sprintf(ac, sizeof(ac), "File system type:           %s\n",
    sFSType);
FS_X_Log(ac);
SEGGER_sprintf(ac, sizeof(ac), "Formatted acc. to SD spec.:           %s\n",
    VolumeInfo.IsSDFormatted ? "Yes" : "No");
FS_X_Log(ac);
SEGGER_sprintf(ac, sizeof(ac), "Has been modified:           %s\n",
    VolumeInfo.IsDirty ? "Yes" : "No");
FS_X_Log(ac);
}
}
```

4.11.24 FS_GetVolumeLabel()

Description

Returns the label of the volume.

Prototype

```
int FS_GetVolumeLabel(const char    * sVolumeName,
                     char          * sVolumeLabel,
                     unsigned      SizeOfVolumeLabel);
```

Parameters

Parameter	Description
<code>sVolumeName</code>	Identifies the volume to be queried. It cannot be <code>NULL</code> .
<code>sVolumeLabel</code>	Buffer that receives the volume label. It cannot be <code>NULL</code> .
<code>SizeOfVolumeLabel</code>	Number of characters in <code>pVolumeName</code> buffer.

Return value

= 0 OK, volume label read.
 ≠ 0 Error code indicating the failure reason.

Additional information

The function stores at most `SizeOfVolumeLabel - 1` bytes to `pVolumeLabel` buffer. The returned volume label is 0-terminated. The volume label is truncated if it contains more characters than the number of characters that can be stored to `pVolumeLabel`.

EFS does not have a volume label. `FS_GetVolumeLabel()` returns with an error if the application tries to read the volume label of a volume formatted as EFS.

Example

```
#include "FS.h"

void SampleGetVolumeName(void) {
    char acVolumeLabel[16];
    int r;

    r = FS_GetVolumeLabel("", acVolumeLabel, sizeof(acVolumeLabel));
    if (r == 0) {
        FS_X_Log("Volume label: ");
        FS_X_Log(acVolumeLabel);
        FS_X_Log("\n");
    }
}
```

4.11.25 FS_GetVolumeName()

Description

Returns the name of a volume.

Prototype

```
int FS_GetVolumeName(int VolumeIndex,
                    char * sVolumeName,
                    int SizeOfVolumeName);
```

Parameters

Parameter	Description
<code>VolumeIndex</code>	0-based index of the volume to be queried.
<code>sVolumeName</code>	out Receives the name of the volume as 0-terminated string. It cannot be NULL.
<code>SizeOfVolumeName</code>	Number of bytes in <code>sVolumeName</code> .

Return value

> 0 Number of bytes required to store the volume name.
 < 0 An error occurred.

Additional information

If the function succeeds, the return value is the length of the string copied to `sVolumeName` in bytes, excluding the 0-terminating character. `FS_GetVolumeName()` stores at most `SizeOfVolumeName - 1` characters to `sVolumeName` and it terminates the string by a 0.

`VolumeIndex` specifies the position of the volume in the internal volume list of the file system. The first volume added to file system in `FS_X_AddDevices()` via `FS_AddDevice()` is stored at index 0 in the volume list, the second volume added via `FS_AddDevice()` is store at the index 1 in the volume list and so on. The total number of volumes can be queried via `FS_GetNumVolumes()`.

If the `sVolumeName` is too small to hold the entire volume name, the return value is the size of the buffer required to hold the volume name plus the terminating 0 character. Therefore, if the return value is greater than `SizeOfVolumeName`, the application has to call `FS_GetVolumeName()` again with a buffer that is large enough to hold the volume name.

Example

```
#include "FS.h"

void SampleGetVolumeName(void) {
    int NumVolumes;
    int iVolume;
    int BufferSize;
    int NumBytesStored;
    char acVolumeName[32];

    BufferSize = sizeof(acVolumeName);
    NumVolumes = FS_GetNumVolumes();
    FS_X_Log("Available volumes:\n");
    for (iVolume = 0; iVolume < NumVolumes; iVolume++) {
        NumBytesStored = FS_GetVolumeName(iVolume, acVolumeName, BufferSize);
        if (NumBytesStored < BufferSize) {
            FS_X_Log(" ");
            FS_X_Log(acVolumeName);
            FS_X_Log("\n");
        }
    }
}
```

4.11.26 FS_GetVolumeSize()

Description

Returns the size of a volume.

Prototype

```
U32 FS_GetVolumeSize(const char * sVolumeName);
```

Parameters

Parameter	Description
<code>sVolumeName</code>	Name of the volume to be queried.

Return value

≠ 0 Total number of bytes available to file system.
 = 0 An error occurred.

Additional information

This function returns the total number of bytes available to file system as data storage. The actual number of bytes available to application for files and directories is smaller than the value returned by `FS_GetVolumeSize()` since the file system requires some space for the boot sector and the allocation table.

A size larger than four Gbytes is reported as `0xFFFFFFFF` because this is the maximum value that can be represented in an unsigned 32-bit integer. The function `FS_GetVolumeSizeKB()` can be used instead if the volume size is larger than four Gbytes.

Example

```
#include <stdio.h>
#include "FS.h"

void SampleGetVolumeSize(void) {
    U32 NumBytes;
    char ac[100];

    NumBytes = FS_GetVolumeSize("");
    if (NumBytes < 0x8000) {
        SEGGER_sprintf(ac, sizeof(ac), "Volume size: %lu Kbytes\n", NumBytes);
    } else {
        NumBytes >>= 10;
        SEGGER_sprintf(ac, sizeof(ac), "Volume size: %lu Mbytes\n", NumBytes);
    }
    FS_X_Log(ac);
}
```

4.11.27 FS_GetVolumeSizeKB()

Description

Returns the size of a volume.

Prototype

```
U32 FS_GetVolumeSizeKB(const char * sVolumeName);
```

Parameters

Parameter	Description
<code>sVolumeName</code>	Name of the volume to be queried.

Return value

≠ 0 Storage available to file system in Kbytes.
 = 0 An error occurred.

Additional information

This function returns the total number of bytes available to file system as data storage. The actual number of bytes available to application for files and directories is smaller than the value returned by `FS_GetVolumeSize()` since the file system requires some space for the boot sector and the allocation table.

Example

```
#include <stdio.h>
#include "FS.h"

void SampleGetVolumeSizeKB(void) {
    U32 NumKBytes;
    char ac[100];

    NumKBytes = FS_GetVolumeSizeKB("");
    SEGGER_sprintf(ac, sizeof(ac), "Volume size: %lu Kbytes\n", NumKBytes);
    FS_X_Log(ac);
}
```

4.11.28 FS_GetVolumeStatus()

Description

Returns the presence status of a volume.

Prototype

```
int FS_GetVolumeStatus(const char * sVolumeName);
```

Parameters

Parameter	Description
<code>sVolumeName</code>	Name of the volume. It cannot be NULL.

Return value

<code>FS_MEDIA_NOT_PRESENT</code>	Storage device is not present.
<code>FS_MEDIA_IS_PRESENT</code>	Storage device is present.
<code>FS_MEDIA_STATE_UNKNOWN</code>	Presence status is unknown.

Additional information

This function can be used to check if a removable storage device that is assigned to a volume is present or not. `FS_GetVolumeStatus()` is typically called periodically from a separate task to handle the insertion and removal of a removable storage device.

Example

```
#include "FS.h"
#include "FS_OS.h"

void SampleUnmountForced(void) {
    int IsPresentNew;
    int IsPresent;

    IsPresent = FS_GetVolumeStatus("");
    while (1) {
        IsPresentNew = FS_GetVolumeStatus("");
        //
        // Check if the presence status of the storage device has been changed.
        //
        if (IsPresentNew != IsPresent) {
            if (IsPresentNew == FS_MEDIA_IS_PRESENT) {
                FS_Mount("");
            } else {
                FS_UnmountForced("");
            }
            IsPresent = IsPresentNew;
        }
        FS_X_OS_Delay(500);
    }
}
```

4.11.29 FS_IsVolumeMounted()

Description

Checks if a volume is mounted.

Prototype

```
int FS_IsVolumeMounted(const char * sVolumeName);
```

Parameters

Parameter	Description
<code>sVolumeName</code>	Name of the volume to be queried.

Return value

- 1 Volume is mounted.
- 0 Volume is not mounted or does not exist.

Additional information

The function returns 1 if the volume is mounted either in read-only mode or in read / write mode.

Example

```
#include "FS.h"

void SampleIsVolumeMounted(void) {
    int IsMounted;

    IsMounted = FS_IsVolumeMounted("");
    if (IsMounted) {
        FS_X_Log("Volume is mounted.\n");
    } else {
        FS_X_Log("Volume is not mounted.\n");
    }
}
```

4.11.30 FS_Lock()

Description

Claims exclusive access to file system.

Prototype

```
void FS_Lock(void);
```

Additional information

The execution of the task that calls this function is suspended until the file system grants it exclusive access. After the task gets exclusive access to file system the other tasks that try to perform file system operations are blocked until the task calls `FS_Unlock()`.

`FS_Lock()` is typically used by applications that call device driver functions from different tasks. These functions are usually not protected against concurrent accesses. Additionally, `FS_Lock()` can be used to protect a group of file system operations against concurrent access.

`FS_Lock()` is available if `FS_OS_LOCKING` set to 1. The function does nothing if `FS_OS_LOCKING` set to 0 or 2. The calls to `FS_Lock()` / `FS_Unlock()` cannot be nested.

The API functions of the file system are multitasking safe. It is not required to explicitly lock these function calls via `FS_Lock()` / `FS_Unlock()`. All API functions call internal versions of `FS_Lock()` and `FS_Unlock()` on function entry and exit respectively.

Example

```
#include "FS.h"

void SampleLock(void) {
    FS_FILE          * pFile;
    FS_NAND_DISK_INFO DiskInfo;

    //
    // The device driver functions are not protected against concurrent
    // access from different tasks. Make sure that only one task can access
    // the file system.
    //
    #if (FS_OS_LOCKING == 1)
        FS_Lock();
    #endif // FS_OS_LOCKING == 1
    FS_NAND_UNI_GetDiskInfo(0, &DiskInfo);
    #if (FS_OS_LOCKING == 1)
        FS_Unlock();
    #endif // FS_OS_LOCKING == 1
    //
    // Make sure that the write operation is not interrupted
    // by a different task.
    //
    #if (FS_OS_LOCKING == 1)
        FS_Lock();
    #endif // FS_OS_LOCKING == 1
    pFile = FS_FOpen("Test.txt", "w");
    if (pFile) {
        FS_Write(pFile, "Test", 4);
        FS_FClose(pFile);
    }
    #if (FS_OS_LOCKING == 1)
        FS_Unlock();
    #endif // FS_OS_LOCKING == 1
}
```

4.11.31 FS_LockVolume()

Description

Claims exclusive access to a volume.

Prototype

```
void FS_LockVolume(const char * sVolumeName);
```

Parameters

Parameter	Description
sVolumeName	Name of the volume that has to be locked.

Additional information

The execution of the task that calls this function is suspended until the file system grants it exclusive access to the specified volume. After the task gets exclusive access to volume the other tasks that try to perform file system operations on that volume are blocked until the task calls `FS_UnlockVolume()` with the same volume name as in the call to `FS_LockVolume()`.

`FS_LockVolume()` is typically used by applications that call device driver functions from different tasks. These functions are usually not protected against concurrent accesses. Additionally, `FS_LockVolume()` can be used to protect a group of file system operations against concurrent access.

`FS_LockVolume()` is available if `FS_OS_LOCKING` set to 2. The function does nothing if `FS_OS_LOCKING` set to 0 or 1. The calls to `FS_LockVolume()` / `FS_UnlockVolume()` cannot be nested.

The API functions of the file system are multitasking safe. It is not required to explicitly lock these function calls via `FS_LockVolume()` / `FS_UnlockVolume()`. All API functions call internal versions of `FS_LockVolume()` and `FS_UnlockVolume()` on function entry and exit respectively.

Example

```
#include "FS.h"

void SampleLockVolume(void) {
    FS_FILE          * pFile;
    FS_NAND_DISK_INFO  DiskInfo;

    //
    // The device driver functions are not protected against concurrent
    // access from different tasks. Make sure that only one task can access
    // the file system.
    //
    #if (FS_OS_LOCKING == 2)
        FS_LockVolume("nand:0:");
    #endif // FS_OS_LOCKING == 2
    FS_NAND_UNI_GetDiskInfo(0, &DiskInfo);
    #if (FS_OS_LOCKING == 2)
        FS_UnlockVolume("nand:0:");
    #endif // FS_OS_LOCKING == 2
    //
    // Make sure that the write operation is not interrupted
    // by a different task.
    //
    #if (FS_OS_LOCKING == 2)
        FS_LockVolume("nand:0:");
    #endif // FS_OS_LOCKING == 2
    pFile = FS_FOpen("nand:0:\\Test.txt", "w");
    if (pFile) {
        FS_Write(pFile, "Test", 4);
        FS_FClose(pFile);
    }
}
```

```
#if (FS_OS_LOCKING == 2)
    FS_UnlockVolume("nand:0:");
#endif // FS_OS_LOCKING == 2
}
```

4.11.32 FS_SetBusyLEDCallback()

Description

Registers a callback for busy status changes of a volume.

Prototype

```
int FS_SetBusyLEDCallback(const char          * sVolumeName,
                          FS_BUSY_LED_CALLBACK * pfBusyLED);
```

Parameters

Parameter	Description
<code>sVolumeName</code>	Name of the volume for which the callback has to be registered. It cannot be <code>NULL</code> .
<code>pfBusyLED</code>	Function to be called when the busy status changes. It cannot be <code>NULL</code> .

Return value

= 0 OK, callback registered.
 ≠ 0 Error code indicating the failure reason.

Additional information

The application can use this `FS_SetBusyLEDCallback()` to register a function that is called by the file system each time the busy status of a volume changes. The volume becomes busy when it starts an access to storage device. When the access to storage device ends the volume becomes ready. The busy status of a volume can change several times during a single file system operation.

`FS_SetBusyLEDCallback()` is available if the `FS_SUPPORT_BUSY_LED` configuration define is set to 1. The function does nothing if `FS_SUPPORT_BUSY_LED` is set to 0.

Example

```
#include "FS.h"

static void _cbBusyLED(U8 OnOff) {
    if (OnOff) {
        //
        // Set LED on.
        //
    } else {
        //
        // Set LED off.
        //
    }
}

void SampleSetBusyLEDCallback(void) {
    FS_FILE * pFile;

    FS_SetBusyLEDCallback("nand:0:", _cbBusyLED);
    pFile = FS_FOpen("nand:0:\\File.txt", "w");
    FS_FClose(pFile);
}
```

4.11.33 FS_SetCharSetType()

Description

Configures the character set that is used for the file and directory names.

Prototype

```
void FS_SetCharSetType(const FS_CHARSET_TYPE * pCharSetType);
```

Parameters

Parameter	Description
<code>pCharSetType</code>	Type of character set used.

Additional information

Permitted values of `pCharSetType` are:

Identifier	Description
<code>FS_CHARSET_CP437</code>	Latin characters
<code>FS_CHARSET_CP932</code>	Japanese characters encoded as Shift JIS
<code>FS_CHARSET_CP936</code>	Simplified Chinese characters encoded as GBK
<code>FS_CHARSET_CP949</code>	Korean characters encoded as UHC
<code>FS_CHARSET_CP950</code>	Chinese characters encoded as Big5

4.11.34 FS_SetFSType()

Description

Sets the type of file system a volume.

Prototype

```
int FS_SetFSType(const char * sVolumeName,
                int      FSType);
```

Parameters

Parameter	Description
<code>sVolumeName</code>	Name of the volume for which the type of the file system has to be set. It cannot be <code>NULL</code> .
<code>FSType</code>	Type of file system. It take be one these values: <ul style="list-style-type: none"> • <code>FS_FAT</code> FAT file system. • <code>FS_EFS</code> SEGGER's Embedded File System.

Return value

= 0 OK, file system type set.
 ≠ 0 Error code indicating the failure reason.

Additional information

This function is optional and available only when both the FAT and the EFS file system are enabled in the file system, that is the `FS_SUPPORT_FAT` and `FS_SUPPORT_EFS` configuration defines are both set to 1 (multiple-volume configuration).

In a multiple-volume configuration the application has to call `FS_SetFSType()` before formatting a volume that has not been formatted before or when the volume has been formatted using a different file system type.

Example

```
#include "FS.h"

void SampleSetFSType(void) {
    //
    // Format the "nand:0:" volume as EFS.
    //
    #if FS_SUPPORT_MULTIPLE_FS
        FS_SetFSType("nand:0:", FS_EFS);
    #endif // FS_SUPPORT_MULTIPLE_FS
    FS_Format("nand:0:", NULL);
    //
    // Format the "nor:0:" volume as FAT.
    //
    #if FS_SUPPORT_MULTIPLE_FS
        FS_SetFSType("nor:0:", FS_FAT);
    #endif // FS_SUPPORT_MULTIPLE_FS
    FS_Format("nor:0:", NULL);
}
```

4.11.35 FS_SetMemCheckCallback()

Description

Registers a callback for checking of 0-copy operations.

Prototype

```
int FS_SetMemCheckCallback(const char * sVolumeName,
                           FS_MEM_CHECK_CALLBACK * pfMemCheck);
```

Parameters

Parameter	Description
<code>sVolumeName</code>	Name of the volume for which the callback has to be registered. It cannot be <code>NULL</code> .
<code>pfMemCheck</code>	Function to be called before a 0-copy operation is executed. It cannot be <code>NULL</code> .

Return value

= 0 OK, callback registered.
 ≠ 0 Error code indicating the failure reason.

Additional information

`FS_SetMemCheckCallback()` can be used by an application to register a function that is called by the file system before any read or write operation to check if a data buffer can be used in 0-copy operation. In a 0-copy operation, a pointer to the data is passed directly to the device driver instead of the data being copied first in an internal buffer and then being passed it to device driver.

Example

```
#include "FS.h"

#if FS_SUPPORT_CHECK_MEMORY

static int _cbMemCheck(void * p, U32 NumBytes) {
    if ((U32)p > 0x100000uL) {
        return 1; // 0-copy allowed.
    } else {
        return 0; // 0-copy not allowed
    }
}

#endif // FS_SUPPORT_CHECK_MEMORY

void SampleSetMemCheckCallback(void) {
    FS_FILE * pFile;

    #if FS_SUPPORT_CHECK_MEMORY
        FS_SetMemCheckCallback("", _cbMemCheck);
    #endif // FS_SUPPORT_CHECK_MEMORY
    pFile = FS_FOpen("File.txt", "w");
    if (pFile) {
        FS_Write(pFile, "Test\n", 5);
    }
    FS_FClose(pFile);
}
```

4.11.36 FS_SetTimeDateCallback()

Description

Configures a function that the file system can use to get the current time and date.

Prototype

```
void FS_SetTimeDateCallback(FS_TIME_DATE_CALLBACK * pfTimeDate);
```

Parameters

Parameter	Description
<code>pfTimeDate</code>	Function to be invoked.

Additional information

During the initialization of the file system via `FS_Init()` the callback function is initialized to point to `FS_X_GetTimeDate()`.

4.11.37 FS_SetVolumeAlias()

Description

Assigns an alternative name for a volume.

Prototype

```
int FS_SetVolumeAlias(const char * sVolumeName,
                    const char * sVolumeAlias);
```

Parameters

Parameter	Description
<code>sVolumeName</code>	in Name of the volume to which the alternative name has to be assigned. It cannot be set to <code>NULL</code> .
<code>sVolumeAlias</code>	in Alternative name as 0-terminated string. Can be set to <code>NULL</code> .

Return value

= 0 OK, the alternative name has been assigned.
 < 0 Error code indicating the failure reason.

Additional information

The assigned alias can be used as replacement in any path to a file or directory that contains a volume name and it can be passed instead of a volume name to any API function that requires one. The alias replaces the volume and the unit number. When used as a volume name the volume separator character (':') has to be added to the end of the alias otherwise it is not recognized as a valid volume name by the file system.

Valid characters in an alias are ASCII capital and small letters, digits and the underscore character. The comparison applied to alias is case sensitive and is performed after the file system checks the real volume names.

The alias name is copied to the internal instance of the volume. The function fails with an error if the alias is longer than the space available in the internal buffer. The size of the internal buffer for the alias can be configured at compile time via `FS_MAX_LEN_VOLUME_ALIAS`. The alias can be removed by either passing a `NULL` or an empty string as `sVolumeAlias` parameter. If `FS_MAX_LEN_VOLUME_ALIAS` is set to 0 then only the pointer to the volume alias is stored. The application has to make sure that the memory region that stores the volume alias remains valid until the file system is deinitialized via `FS_DeInit()`.

This function is available only when `FS_SUPPORT_VOLUME_ALIAS` is set to 1.

The alias of a volume can be queried either via `FS_GetVolumeInfo()` or `FS_GetVolumeInfoEx()`. The `sAlias` member of the `FS_DISK_INFO` structure stores the configured alias. In addition, the volume alias can be obtained via `FS_GetVolumeAlias()`.

Example

```
#include "FS.h"

void SampleSetVolumeAlias(void) {
    FS_SetVolumeAlias("nor:0:", "flash");
}
```

4.11.38 FS_SetVolumeLabel()

Description

Modifies the label of a volume.

Prototype

```
int FS_SetVolumeLabel(const char * sVolumeName,
                     const char * sVolumeLabel);
```

Parameters

Parameter	Description
<code>sVolumeName</code>	Name of the volume for which the label has to be modified. It cannot be <code>NULL</code> .
<code>sVolumeLabel</code>	Volume label as 0-terminated ASCII string. The volume label is deleted if set to <code>NULL</code> .

Return value

= 0 OK, volume label set.
 ≠ 0 Error code indicating the failure reason.

Additional information

The volume label is a ASCII string that can be assigned to a volume. It is not evaluated by the file system and it cannot be used as volume name. A Windows PC shows the volume label of a removable storage device in the "Computer" window when it is mounted via USB MSD. The volume label can be read via `FS_GetVolumeLabel()`.

The volume label of a FAT-formatted volume can contain at most 11 characters. The following characters are not allowed in a volume name: '^', '&', '*', '+', '-', ',', '.', '/', ':', ';', '<', '=', '>', '?', '[', ']', '\'.

EFS does not have a volume label. `FS_GetVolumeLabel()` returns with an error if the application tries to read the volume label of a volume formatted as EFS.

Example

```
#include "FS.h"

void SampleSetVolumeName(void) {
    FS_SetVolumeLabel("", "SEgger");
}
```

4.11.39 FS_TimeStampToFileTime()

Description

Converts a timestamp to a broken-down date and time specification.

Prototype

```
void FS_TimeStampToFileTime(U32          TimeStamp,
                           FS_FILETIME * pFileTime);
```

Parameters

Parameter	Description
<code>TimeStamp</code>	Timestamp to be converted.
<code>pFileTime</code>	out Converted broken-down date and time. It cannot be NULL.

Additional information

This function can be used to convert a timestamp as used by the file system a broken-down date and time specification.

For a description of the timestamp format refer to `FS_GetFileTime()`.

Example

```
#include <stdio.h>
#include "FS.h"

void SampleGetFileTime(void) {
    char    ac[100];
    U32     TimeStamp;
    FS_FILETIME FileTime;
    int     r;

    r = FS_GetFileTime("Test.txt", &TimeStamp);
    if (r == 0) {
        FS_TimeStampToFileTime(TimeStamp, &FileTime);
        SEGGER_sprintf(ac, sizeof(ac), "Creation time: %d-%.2d-%.2d %.2d:%.2d:%.2d",
            FileTime.Year, FileTime.Month, FileTime.Day,
            FileTime.Hour, FileTime.Minute, FileTime.Second);
        FS_X_Log(ac);
    }
}
```

4.11.40 FS_Unlock()

Description

Releases the exclusive access to file system.

Prototype

```
void FS_Unlock(void);
```

Additional information

This function has to be called in pair with `FS_Lock()` to allow other tasks to access the file system. For each call to `FS_Lock()` the application has to call `FS_Unlock()`.

`FS_Unlock()` is available if `FS_OS_LOCKING` set to 1. The function does nothing if `FS_OS_LOCKING` set to 0 or 2. The calls to `FS_Lock()` / `FS_Unlock()` cannot be nested.

Example

Refer to `FS_Lock()` for an example usage.

4.11.41 FS_UnlockVolume()

Description

Releases the exclusive access to a volume.

Prototype

```
void FS_UnlockVolume(const char * sVolumeName);
```

Parameters

Parameter	Description
<code>sVolumeName</code>	Name of the volume that has to be locked.

Additional information

This function has to be called in pair with `FS_LockVolume()` to allow other tasks to access the volume. For each call to `FS_LockVolume()` the application has to call `FS_UnlockVolume()` with the same volume name as parameter.

`FS_UnlockVolume()` is available if `FS_OS_LOCKING` set to 2. The function does nothing if `FS_OS_LOCKING` set to 0 or 1. The calls to `FS_LockVolume()` / `FS_UnlockVolume()` cannot be nested.

Example

Refer to `FS_LockVolume()` for an example usage.

4.11.42 Disk checking error codes

Description

Error codes reported by `FS_CheckDisk()` during operation.

Definition

```
#define FS_CHECKDISK_ERRCODE_0FILE           0x10
#define FS_CHECKDISK_ERRCODE_SHORTEN_CLUSTER 0x11
#define FS_CHECKDISK_ERRCODE_CROSSLINKED_CLUSTER 0x12
#define FS_CHECKDISK_ERRCODE_FEW_CLUSTER     0x13
#define FS_CHECKDISK_ERRCODE_CLUSTER_UNUSED  0x14
#define FS_CHECKDISK_ERRCODE_CLUSTER_NOT_EOC 0x15
#define FS_CHECKDISK_ERRCODE_INVALID_CLUSTER 0x16
#define FS_CHECKDISK_ERRCODE_INVALID_DIRECTORY_ENTRY 0x17
#define FS_CHECKDISK_ERRCODE_SECTOR_NOT_IN_USE 0x18
#define FS_CHECKDISK_ERRCODE_INVALID_FILE    0x19
```

Symbols

Definition	Description
<code>FS_CHECKDISK_ERRCODE_0FILE</code>	A cluster chain is assigned to a file that does not contain any data.
<code>FS_CHECKDISK_ERRCODE_SHORTEN_CLUSTER</code>	The cluster chain assigned to a file is longer than the size of the file.
<code>FS_CHECKDISK_ERRCODE_CROSSLINKED_CLUSTER</code>	A cluster is assigned to more than one file or directory.
<code>FS_CHECKDISK_ERRCODE_FEW_CLUSTER</code>	The size of the file is larger than the cluster chain assigned to file.
<code>FS_CHECKDISK_ERRCODE_CLUSTER_UNUSED</code>	A cluster is marked as in use, but not assigned to any file or directory.
<code>FS_CHECKDISK_ERRCODE_CLUSTER_NOT_EOC</code>	A cluster is does not have end-of-chain marker.
<code>FS_CHECKDISK_ERRCODE_INVALID_CLUSTER</code>	Invalid cluster id.
<code>FS_CHECKDISK_ERRCODE_INVALID_DIRECTORY_ENTRY</code>	Invalid directory entry.
<code>FS_CHECKDISK_ERRCODE_SECTOR_NOT_IN_USE</code>	A logical sector that stores data is not marked as in use in the device driver.
<code>FS_CHECKDISK_ERRCODE_INVALID_FILE</code>	A fragment file was found that does not belong to any big file.

Additional information

The error codes are reported via the `ErrCode` parameter of the callback function.

Example

Refer to `FS_CheckDisk()` for an example usage.

4.11.43 Disk checking return values

Description

Error codes returned by `FS_CheckDisk()`.

Definition

```
#define FS_CHECKDISK_RETVAL_OK           0
#define FS_CHECKDISK_RETVAL_RETRY       1
#define FS_CHECKDISK_RETVAL_ABORT       2
#define FS_CHECKDISK_RETVAL_MAX_RECURSE 3
#define FS_CHECKDISK_RETVAL_CONTINUE    4
#define FS_CHECKDISK_RETVAL_SKIP        5
```

Symbols

Definition	Description
<code>FS_CHECKDISK_RETVAL_OK</code>	OK, file system not in corrupted state
<code>FS_CHECKDISK_RETVAL_RETRY</code>	An error has be found and repaired, retry is required.
<code>FS_CHECKDISK_RETVAL_ABORT</code>	User aborted operation via callback or API call
<code>FS_CHECKDISK_RETVAL_MAX_RECURSE</code>	Maximum recursion level reached, operation aborted
<code>FS_CHECKDISK_RETVAL_CONTINUE</code>	<code>FS_CheckAT()</code> returns this value to indicate that the allocation table has not been entirely checked.
<code>FS_CHECKDISK_RETVAL_SKIP</code>	<code>FS_CheckDir()</code> returns this value to indicate that the directory entry does not have to be checked.

Example

Refer to `FS_CheckDisk()` for an example usage.

4.11.44 Disk checking action codes

Description

Values returned by the `FS_CheckDisk()` callback function.

Definition

```
#define FS_CHECKDISK_ACTION_DO_NOT_REPAIR    0
#define FS_CHECKDISK_ACTION_SAVE_CLUSTERS   1
#define FS_CHECKDISK_ACTION_ABORT           2
#define FS_CHECKDISK_ACTION_DELETE_CLUSTERS 3
```

Symbols

Definition	Description
<code>FS_CHECKDISK_ACTION_DO_NOT_REPAIR</code>	The error does not have to be repaired.
<code>FS_CHECKDISK_ACTION_SAVE_CLUSTERS</code>	The data stored in the clusters of a faulty cluster chain has to be saved to a file.
<code>FS_CHECKDISK_ACTION_ABORT</code>	The disk checking operation has to be aborted.
<code>FS_CHECKDISK_ACTION_DELETE_CLUSTERS</code>	The data stored in the clusters of a faulty cluster chain has to be deleted.

Additional information

These values indicate `FS_CheckDisk()` how to handle a file system error.

Example

Refer to `FS_CheckDisk()` for an example usage.

4.11.45 File system types

Description

Types of file systems supported by emFile.

Definition

```
#define FS_FAT                0
#define FS_EFS                1
#define FS_FAT_TYPE_UNKONWN  0u
#define FS_FAT_TYPE_FAT12    12u
#define FS_FAT_TYPE_FAT16    16u
#define FS_FAT_TYPE_FAT32    32u
```

Symbols

Definition	Description
FS_FAT	File Allocation Table (FAT).
FS_EFS	SEGGER's Embedded File System (EFS).
FS_FAT_TYPE_UNKONWN	Internal use.
FS_FAT_TYPE_FAT12	Internal use.
FS_FAT_TYPE_FAT16	Internal use.
FS_FAT_TYPE_FAT32	Internal use.

4.11.46 Format types

Description

Types of format supported by the emFile.

Definition

```
#define FS_TYPE_FAT12    0x000Cu
#define FS_TYPE_FAT16    0x0010u
#define FS_TYPE_FAT32    0x0020u
#define FS_TYPE_EFS      0x0120u
```

Symbols

Definition	Description
<code>FS_TYPE_FAT12</code>	FAT with 12-bit allocation table entries.
<code>FS_TYPE_FAT16</code>	FAT with 16-bit allocation table entries.
<code>FS_TYPE_FAT32</code>	FAT with 32-bit allocation table entries.
<code>FS_TYPE_EFS</code>	SEGGER's Embedded File System (EFS).

4.11.47 FS_BUSY_LED_CALLBACK

Description

Type of function called by the file system to report a change in the busy status of a volume.

Type definition

```
typedef void FS_BUSY_LED_CALLBACK(U8 OnOff);
```

Parameters

Parameter	Description
OnOff	Indicates if the volume is busy or not. <ul style="list-style-type: none"> • 1 The volume is busy. • 0 The volume is ready.

Additional information

A function of this type can be registered with the file system via `FS_SetBusyLEDCallback()`. `FS_BUSY_LED_CALLBACK()` is called by the file system each time the volume changes the busy status from busy to ready and reverse. Therefore, an application can use `FS_BUSY_LED_CALLBACK()` to indicate the busy / ready status of a volume via LED or by other means.

The file system calls `FS_BUSY_LED_CALLBACK()` with `OnOff` set to 1 when the volume goes busy. When the volume becomes ready `FS_BUSY_LED_CALLBACK()` is called again with `OnOff` set to 0.

Example

Refer to `FS_SetBusyLEDCallback()` for an example usage.

4.11.48 FS_CHECKDISK_ON_ERROR_CALLBACK

Description

Type of function called by `FS_CheckDisk()` to report an error.

Type definition

```
typedef int FS_CHECKDISK_ON_ERROR_CALLBACK(int ErrCode,
                                           ... ..);
```

Parameters

Parameter	Description
<code>ErrCode</code>	Code of the reported error.

Return value

Value that indicates `FS_CheckDisk()` how the error should be handled.

Additional information

`ErrCode` is one of the `FS_CHECKDISK_ERRCODE_...` defines. The value returned by `FS_CHECKDISK_ON_ERROR_CALLBACK()` can be one of the `FS_CHECKDISK_ACTION_...` defines.

In addition to `ErrCode` `FS_CheckDisk()` can pass other parameters `FS_CHECKDISK_ON_ERROR_CALLBACK()` providing information about the reported error. These parameters can be directly passed to a `printf()`-style function along with the format returned by `FS_CheckDisk_ErrCode2Text()` to create a text description of the error in human-readable format.

Example

Refer to `FS_CheckDisk()` for an example usage.

4.11.49 FS_CHS_ADDR

Description

Address of physical block on a mechanical drive.

Type definition

```
typedef struct {
    U16 Cylinder;
    U8   Head;
    U8   Sector;
} FS_CHS_ADDR;
```

Structure members

Member	Description
Cylinder	Cylinder number (0-based)
Head	Read / write head (0-based)
Sector	Index of the sector on a cylinder.

4.11.50 FS_DISK_INFO

Description

Information about a volume.

Type definition

```
typedef struct {
    U32      NumTotalClusters;
    U32      NumFreeClusters;
    U16      SectorsPerCluster;
    U16      BytesPerSector;
    U16      NumRootDirEntries;
    U16      FSType;
    U8       IsSDFormatted;
    U8       IsDirty;
    const char * sAlias;
    void      * pBuffer;
    int      SizeOfBuffer;
} FS_DISK_INFO;
```

Structure members

Member	Description
NumTotalClusters	Total number of clusters on the storage device.
NumFreeClusters	Number of clusters that are not in use.
SectorsPerCluster	Number of sectors in a cluster.
BytesPerSector	Size of the logical sector in bytes.
NumRootDirEntries	Number of directory entries in the root directory. This member is valid only for volumes formatted as <code>FS_TYPE_FAT12</code> or <code>FS_TYPE_FAT16</code> .
FSType	Type of file system. One of <code>FS_TYPE_...</code> defines.
IsSDFormatted	Set to 1 if the volume has been formatted according to SD specification. This member is valid only for volumes formatted as FAT.
IsDirty	Set to 1 if the volume was not unmounted correctly or the file system modified the storage. This member is valid only for volumes formatted as FAT.
sAlias	Alternative name of the volume (0-terminated). Set to <code>NULL</code> if the volume alias feature is disabled.
pBuffer	Buffer to be used for the access to the storage device.
SizeOfBuffer	Number of bytes in pBuffer .

Additional information

[IsDirty](#) can be used to check if the volume formatted as FAT has been correctly unmounted before a system reset. [IsDirty](#) is set to 1 at file system initialization if the file system was not properly unmounted.

The members [pBuffer](#) and [SizeOfBuffer](#) can be used to specify a work buffer for the operation that calculates the available free space. This work buffer is used by the file system to read data from the allocation table of the file system. Specifying a work buffer larger than a logical sector size can help increasing the performance of the operation when using a storage device that can efficiently perform read burst operations such as SD card, eMMC device or USB drive. The file system is able to use the work buffer for burst operations only if [pBuffer](#) is aligned according to the value configured via `FS_DRIVER_ALIGNMENT`. The work buffer is used only when the flag `FS_DISKINFO_FLAG_WORK_BUFFER` is set in the `Flags` parameter passed to `FS_GetVolumeInfoEx()` and the file system is built with

FS_SUPPORT_SECTOR_BUFFER_BURST set to 1. The file system uses an internal sector buffer for the operation if either `pBuffer` is set to `NULL` or `SizeOfBuffer` is set to 0.

Example

Refer to `FS_GetVolumeInfo()` for an example usage.

4.11.51 FS_FILETIME

Description

Time and date representation.

Type definition

```
typedef struct {
    U16 Year;
    U16 Month;
    U16 Day;
    U16 Hour;
    U16 Minute;
    U16 Second;
} FS_FILETIME;
```

Structure members

Member	Description
Year	Year (The value has to be greater than 1980.)
Month	Month (1--12, 1: January, 2: February, etc.)
Day	Day of the month (1--31)
Hour	Hour (0--23)
Minute	Minute (0--59)
Second	Second (0--59)

Additional information

FS_FILETIME represents a timestamp using individual members for the month, day, year, weekday, hour, minute, and second values. This can be useful for getting or setting a timestamp of a file or directory. The conversion between timestamp and FS_FILETIME can be done using FS_FileTimeToTimeStamp() and FS_TimeStampToFileTime()

4.11.52 FS_FREE_SPACE_DATA

Description

Information the number of free space available on a volume.

Type definition

```
typedef struct {
    U32          NumClustersFree;
    int          SizeOfBuffer;
    void        * pBuffer;
    FS_VOLUME *  pVolume;
    U32          FirstClusterId;
} FS_FREE_SPACE_DATA;
```

Structure members

Member	Description
NumClustersFree	Number of unallocated clusters found.
SizeOfBuffer	Internal. Do not use. Number of bytes in the work buffer.
pBuffer	Internal. Do not use. Work buffer.
pVolume	Internal. Do not use. Volume information.
FirstClusterId	Internal. Do not use. Id of the first cluster to be checked.

Additional information

This structure stores the result and context of the operation that calculates the amount of free space available on a volume. The amount of free space is returned as a number of clusters via the [NumClustersFree](#) member. The members of the search context are considered internal and should not be used by the application. `FS_FREE_SPACE_DATA` is used by the `FS_GetVolumeFreeSpaceFirst()` `FS_GetVolumeFreeSpaceNext()` pair of API functions.

4.11.53 FS_MEM_CHECK_CALLBACK

Description

Type of function called by the file system to check if a memory region can be used in a 0-copy operation.

Type definition

```
typedef int FS_MEM_CHECK_CALLBACK(void * pMem,
                                   U32   NumBytes);
```

Parameters

Parameter	Description
pMem	Points to the first byte in the memory area to be checked.
NumBytes	Size of the memory area in bytes.

Return value

≠ 0 The memory region can be used in a 0 copy operation.
 = 0 The memory region cannot be used in a 0 copy operation.

Additional information

A function of this type is called by the file system before any read or write operation performed by the application. The function has to check if the memory region defined by [pMem](#) and [NumBytes](#) can be passed directly to the device driver during a 0-copy operation.

The callback function is typically required on a system where the device driver uses DMA to transfer data to and from the storage device and where not all the memory regions can be accessed by the DMA. If the memory region cannot be accessed by DMA the callback function has to return 0. The file system copies then the data to an internal buffer that is accessible to DMA and performs the data transfer. The callback has to return a value different than 0 if the DMA can access the specified memory region. In this case the memory region is passed directly to device driver to perform the data transfer and the internal copy operation of the file system is skipped.

4.11.54 FS_MEM_INFO

Description

Information about the memory management.

Type definition

```
typedef struct {
    U8    IsExternal;
    U32   NumBytesTotal;
    U32   NumBytesAllocated;
} FS_MEM_INFO;
```

Structure members

Member	Description
IsExternal	Memory allocator type.
NumBytesTotal	Size of the memory pool in bytes.
NumBytesAllocated	Number of bytes allocated from the memory pool.

Additional information

The information can be queried via `FS_GetMemInfo()`.

[IsExternal](#) contains the value of the `FS_SUPPORT_EXT_MEM_MANAGER` configuration define.

If the file system is configured to use the internal memory allocator (`FS_SUPPORT_EXT_MEM_MANAGER` set to 0) then [NumBytesTotal](#) stores the value passed as second parameter to `FS_AssignMemory()`. [NumBytesTotal](#) is set to 0 if the file system is configured to use an external memory allocator (`FS_SUPPORT_EXT_MEM_MANAGER` set to 1) because this value is not known to the file system.

The value of [NumBytesAllocated](#) stores the number of bytes allocated by the file system at the time `FS_GetMemInfo()` is called. In emFile versions older than 5.xx this information was stored in the global variable `FS_NumBytesAllocated`.

4.11.55 FS_TIME_DATE_CALLBACK

Description

Type of function called by the file system to get the actual time and date.

Type definition

```
typedef U32 FS_TIME_DATE_CALLBACK(void);
```

Return value

Current time and date in a format suitable for the file system.

Additional information

The time and date have to be encoded as follows: Bit 0-4: 2-second count (0-29) Bit 5-10: Minutes (0-59) Bit 11-15: Hours (0-23) Bit 16-20: Day of month (1-31) Bit 21-24: Month of year (1-12) Bit 25-31: Count of years from 1980 (0-127) The callback function can be registered via `FS_SetTimeDateCallback()`. `FS_X_GetTimeDate()` is set as default callback function at the file system initialization. The application has to provide the implementation of `FS_X_GetTimeDate()`.

Example

Refer to `FS_SetTimeDateCallback()` for an example usage.

4.11.56 Volume information flags

Description

Flags that control the information returned by `FS_GetVolumeInfoEx()`.

Definition

```
#define FS_DISKINFO_FLAG_FREE_SPACE    0x01
#define FS_DISKINFO_FLAG_WORK_BUFFER  0x02
```

Symbols

Definition	Description
<code>FS_DISKINFO_FLAG_FREE_SPACE</code>	Returns the available free space on the storage device.
<code>FS_DISKINFO_FLAG_WORK_BUFFER</code>	Specifies a working buffer for the read operations.

4.12 Storage layer functions

The functions described in this section can be used to access and to manage the data at the logical sector level effectively bypassing the file system. These functions are typically used when the application comes with its own file system or when the storage device has to be mounted as mass storage device via USB.

4.12.1 FS_STORAGE_Clean()

Description

Performs garbage collection on a volume.

Prototype

```
int FS_STORAGE_Clean(const char * sVolumeName);
```

Parameters

Parameter	Description
<code>sVolumeName</code>	Name of the volume on which to perform the garbage collection.

Return value

= 0 OK, volume cleaned.
 ≠ 0 Error code indicating the failure reason.

Additional information

The application can call this function to convert storage blocks that contain invalid data to free space that can be used to store new data. This operation is supported only by storage devices that are managed by the file system such as NAND and NOR flash.

`FS_STORAGE_Clean()` is optional since the device drivers perform the garbage collection operation automatically. The function can be used to increase the write performance by preparing the storage device in advance of the write operation.

The actions executed by `FS_STORAGE_Clean()` depend on the device driver used. For example, the Sector Map NOR driver converts all logical blocks that contain invalid data into free (writable) logical blocks. As a consequence, the following write operation will run faster because physical sectors does not have to be erased.

`FS_STORAGE_Clean()` can potentially take a long time to complete, preventing the access of other tasks to the file system. How long the execution takes depends on the type of storage device and on the number of storage blocks that contain invalid data. The file system provides an alternative function `FS_STORAGE_CleanOne()` that completes in a shorter period of time than `FS_STORAGE_Clean()`. This is realized by executing only one sub-operation of the entire garbage collection operation at a time. For more information refer to `FS_STORAGE_CleanOne()`.

Additional information about the garbage collection operation can be found in the "Garbage collection" section of the NAND and NOR drivers of the emFile manual.

Example

```
#include "FS.h"

void SampleStorageClean(void) {
    FS_FILE * pFile;

    //
    // Perform garbage collection on the storage device.
    //
    FS_STORAGE_Clean("nor:0:");
    //
    // The write to file is fast since the NOR driver does not have to perform
    // any garbage collection during the write operation.
    //
    pFile = FS_FOpen("nor:0:\\File.txt", "w");
    if (pFile) {
        FS_Write(pFile, "Test", 4);
        FS_FClose(pFile);
    }
}
```

```
}
```

4.12.2 FS_STORAGE_CleanEx()

Description

Performs garbage collection on a volume.

Prototype

```
int FS_STORAGE_CleanEx(FS_VOLUME * pVolume);
```

Parameters

Parameter	Description
<code>pVolume</code>	Instance of the volume on which to perform the garbage collection.

Return value

= 0 OK, volume cleaned.
≠ 0 Error code indicating the failure reason.

Additional information

This function performs the same operation as `FS_STORAGE_Clean()` with the difference that the volume is specified via a volume instance instead of a volume name.

4.12.3 FS_STORAGE_CleanOne()

Description

Performs garbage collection on a volume.

Prototype

```
int FS_STORAGE_CleanOne(const char * sVolumeName,
                       int * pMoreToClean);
```

Parameters

Parameter	Description
<code>sVolumeName</code>	Name of the storage volume on which to perform the garbage collection.
<code>pMoreToClean</code>	out Indicates if the storage device has been cleaned completely or not. It can be NULL. <ul style="list-style-type: none"> ≠0 Not cleaned completely. =0 Completely clean.

Return value

= 0 OK, clean operation executed.
≠ 0 Error code indicating the failure reason.

Additional information

This function performs the same operation as `FS_STORAGE_Clean()` with the difference that it executes only one sub-operation of the garbage collection operation at a time. This is practical if other tasks of the application require access to the file system before the garbage collection operation is completed. The completion of the garbage collection operation is indicated via `pMoreToClean`. `FS_STORAGE_CleanOne()` returns a value different than 0 via `pMoreToClean` if the operation is not completed.

Additional information about the garbage collection operation can be found in the "Garbage collection" section of the NAND and NOR drivers.

Example

```
#include "FS.h"

void SampleStorageCleanOne(void) {
    FS_FILE * pFile;
    int      MoreToClean;

    //
    // Perform garbage collection on the storage device.
    //
    MoreToClean = 0;
    do {
        FS_STORAGE_CleanOne("nand:0:", &MoreToClean);
    } while (MoreToClean);
    //
    // The write to file is fast since the NAND driver does not have to perform
    // any garbage collection during the write operation.
    //
    pFile = FS_FOpen("nand:0:\\File.txt", "w");
    if (pFile) {
        FS_Write(pFile, "Test", 4);
        FS_FClose(pFile);
    }
}
```

4.12.4 FS_STORAGE_CleanOneEx()

Description

Performs garbage collection on a volume.

Prototype

```
int FS_STORAGE_CleanOneEx(FS_VOLUME * pVolume,
                          int * pMoreToClean);
```

Parameters

Parameter	Description
<code>pVolume</code>	Instance of the storage volume on which to perform the garbage collection.
<code>pMoreToClean</code>	out Indicates if the storage device has been cleaned completely or not. It can be <code>NULL</code> . <ul style="list-style-type: none"> • <code>≠0</code> Not cleaned completely. • <code>=0</code> Completely clean.

Return value

`= 0` OK, clean operation executed.
`≠ 0` Error code indicating the failure reason.

Additional information

This function performs the same operation as `FS_STORAGE_CleanOne()` with the difference that the volume is specified via a volume instance instead of a volume name.

4.12.5 FS_STORAGE_DeInit()

Description

Frees the resources allocated by the storage layer.

Prototype

```
void FS_STORAGE_DeInit(void);
```

Additional information

This function is optional. `FS_STORAGE_DeInit()` frees all resources that are allocated by the storage layer after initialization. The application can call this function only after it called `FS_STORAGE_Init()`.

This function is available if the emFile sources are compiled with the `FS_SUPPORT_DEINIT` configuration define set to 1.

Example

```
#include "FS.h"

void SampleStorageDeInit(void) {
    FS_STORAGE_Init();
#ifdef FS_SUPPORT_DEINIT
    //
    // Access the storage layer...
    //
    FS_STORAGE_DeInit();
#endif // FS_SUPPORT_DEINIT
    //
    // The storage layer cannot be accessed anymore.
    //
}
```

4.12.6 FS_STORAGE_FillSectors()

Description

Writes the same sector data to one or more logical sectors.

Prototype

```
int FS_STORAGE_FillSectors(const char * sVolumeName,
                          const void * pData,
                          U32   SectorIndex,
                          U32   NumSectors);
```

Parameters

Parameter	Description
sVolumeName	Name of the volume to write to. It cannot be NULL.
pData	in Buffer that contains the sector data to be written. It cannot be NULL.
SectorIndex	Index of the first sector to be written.
NumSectors	Number of sectors to be written.

Return value

= 0 OK, sector data modified.
 ≠ 0 Error code indicating the failure reason.

Additional information

This function can be used to write the same sector data to multiple consecutive logical sectors. [pData](#) has to point to a memory region that stores the contents of a single logical sector that has to be written.

The size of the logical sector depends on the type of storage device used. The application can query the size of the logical sector as well as the number of logical sectors of a storage device via [FS_STORAGE_GetDeviceInfo\(\)](#). Typically, the size of a logical sector is 512 bytes.

[SectorIndex](#) is a 0-based index that identifies the first logical sector to be written. The range of the logical sectors modified by this function is [SectorIndex](#) to [SectorIndex](#) + [NumSectors](#) - 1.

[FS_STORAGE_FillSectors\(\)](#) reports an error and does not perform any operation if the specified range of logical sectors exceeds the size of the storage device.

4.12.7 FS_STORAGE_FillSectorsEx()

Description

Writes the same sector data to one or more logical sectors.

Prototype

```
int FS_STORAGE_FillSectorsEx(    FS_VOLUME * pVolume,
                                const void * pData,
                                U32      SectorIndex,
                                U32      NumSectors);
```

Parameters

Parameter	Description
<code>pVolume</code>	Instance of the volume to write to.
<code>pData</code>	in Contents of the logical sector.
<code>SectorIndex</code>	Index of the logical sector to be written.
<code>NumSectors</code>	Number of logical sectors to be written.

Return value

= 0 OK, logical sectors written successfully.
 ≠ 0 Error code indicating the failure reason.

Additional information

This function performs the same operation as `FS_STORAGE_FillSectors()` with the difference that the volume is specified via a volume instance instead a volume name. The application can get a volume instance from a volume name by calling `FS_STORAGE_FindVolume()`.

4.12.8 FS_STORAGE_FindVolume()

Description

Searches for a volume instance by name.

Prototype

```
FS_VOLUME *FS_STORAGE_FindVolume(const char * sVolumeName);
```

Parameters

Parameter	Description
<code>sVolumeName</code>	Name of the volume.

Return value

≠ NULL Pointer to the volume instance.
= NULL Volume not found.

Additional information

This function returns the volume instance assigned to the specified volume name. The return value can be passed as parameter to the API functions of the Storage layer that identify a volume by instance and not by name.

The returned volume instance is no longer valid after the file system is deinitialized via a call to `FS_DeInit()`. The application must call `FS_STORAGE_FindVolume()` to get a new volume instance after the file system is reinitialized.

4.12.9 FS_STORAGE_FindVolumeByDevice()

Description

Searches for a volume instance by index.

Prototype

```
FS_VOLUME *FS_STORAGE_FindVolumeByDevice(FS_DEVICE * pDevice);
```

Parameters

Parameter	Description
<code>pDevice</code>	Device instance assigned to the volume.

Return value

≠ NULL Pointer to the volume instance.
= NULL Volume not found.

Additional information

This function performs the same operation as `FS_STORAGE_FindVolumeByIndex()` with the difference that the volume to be searched for is specified via device instance instead of volume index.

A device index can be obtained via the callback of the function registered via `FS_STORAGE_SetOnDeviceActivityCallback()` or `FS_STORAGE_SetOnDeviceActivityCallbackEx()`.

4.12.10 FS_STORAGE_FindVolumeByIndex()

Description

Searches for a volume instance by index.

Prototype

```
FS_VOLUME *FS_STORAGE_FindVolumeByIndex(int VolumeIndex);
```

Parameters

Parameter	Description
<code>VolumeIndex</code>	Index of the volume.

Return value

≠ NULL Pointer to the volume instance.
= NULL Volume not found.

Additional information

This function returns the volume instance assigned to the volume with the specified index. The first volume added to the file system via `FS_AddDevice()` has the index 0, the second index 1 and so on. The total number of configured volumes can be queried via `FS_Get-NumVolumes()`.

The return value of this function can be passed as parameter to the API functions of the Storage layer that identify a volume by instance and not by name.

The returned volume instance is no longer valid after the file system is deinitialized via a call to `FS_DeInit()`. The application must call `FS_STORAGE_FindVolumeByIndex()` to get a new volume instance after the file system is reinitialized.

4.12.11 FS_STORAGE_FormatLowEx()

Description

Formats the storage device.

Prototype

```
int FS_STORAGE_FormatLowEx(FS_VOLUME * pVolume);
```

Parameters

Parameter	Description
<code>pVolume</code>	Instance of the volume to be formatted.

Return value

= 0 OK, low level format was successful.
≠ 0 Error code indicating the failure reason.

Additional information

This function performs the same operation as `FS_FormatLow()` with the difference that the volume to be queried is identified by a volume instance instead a volume name. The application can get a volume instance from a volume name by calling `FS_STORAGE_FindVolume()`.

4.12.12 FS_STORAGE_FreeSectors()

Description

Informs the driver about unused sectors.

Prototype

```
int FS_STORAGE_FreeSectors(const char * sVolumeName,
                          U32      SectorIndex,
                          U32      NumSectors);
```

Parameters

Parameter	Description
<code>sVolumeName</code>	Name of the volume on which to perform the operation.
<code>SectorIndex</code>	Index of the first logical sector to be marked as invalid (0-based).
<code>NumSectors</code>	Number of sectors to be marked as invalid starting with <code>SectorIndex</code> .

Return value

= 0 OK, sectors freed.
 ≠ 0 Error code indicating the failure reason

Additional information

Typically, this function is called by the application to inform the driver which logical sectors are no longer used for data storage. The NAND and NOR drivers can use this information to optimize the internal relocation of data blocks during the wear-leveling operation. The data of the logical sectors marked as not in use is not copied anymore that can typically lead to an improvement of the write performance.

`FS_STORAGE_FreeSectors()` performs a similar operation as the trim command of SSDs (Solid-State Drives). The data stored to a logical sector is no longer available to an application after the logical sector has been freed via `FS_STORAGE_FreeSectors()`,

Example

```
#include "FS.h"

void SampleStorageFreeSectors(void) {
    //
    // Inform the NAND driver that the logical sectors
    // with the indexes 2, 3, and 4 are no longer in use.
    //
    FS_STORAGE_FreeSectors("nand:0:", 2, 3);
}
```

4.12.13 FS_STORAGE_FreeSectorsEx()

Description

Informs the driver about unused sectors.

Prototype

```
int FS_STORAGE_FreeSectorsEx(FS_VOLUME * pVolume,
                             U32       SectorIndex,
                             U32       NumSectors);
```

Parameters

Parameter	Description
<code>pVolume</code>	Instance of the volume on which to perform the operation.
<code>SectorIndex</code>	Index of the first logical sector to be marked as invalid (0-based).
<code>NumSectors</code>	Number of sectors to be marked as invalid starting with <code>SectorIndex</code> .

Return value

= 0 OK, sectors freed.
 ≠ 0 Error code indicating the failure reason.

Additional information

This function performs the same operation as `FS_STORAGE_FreeSectors()` with the difference that the volume is specified via a volume instance instead of a volume name.

4.12.14 FS_STORAGE_GetAutoMountType()

Description

Returns information about how a volume is automatically mounted.

Prototype

```
int FS_STORAGE_GetAutoMountType(const char * sVolumeName);
```

Parameters

Parameter	Description
<code>sVolumeName</code>	Name of the volume to be queried.

Return value

= 0 Volume is not mounted automatically.
= FS_MOUNT_RO Volume is mounted automatically in read only mode.
= FS_MOUNT_RW Volume is mounted automatically in read and write mode.
< 0 Error code indicating the failure reason. Refer to `FS_ErrorNo2Text()`.

Additional information

This function is available only if the file system is built with `FS_STORAGE_SUPPORT_MOUNT` set to 1.

4.12.15 FS_STORAGE_GetAutoMountTypeEx()

Description

Returns information about how a volume is automatically mounted.

Prototype

```
int FS_STORAGE_GetAutoMountTypeEx(FS_VOLUME * pVolume);
```

Parameters

Parameter	Description
<code>pVolume</code>	Instance of the volume to be queried.

Return value

= 0 Volume is not mounted automatically.
 = FS_MOUNT_RO Volume is mounted automatically in read only mode.
 = FS_MOUNT_RW Volume is mounted automatically in read and write mode.
 < 0 Error code indicating the failure reason. Refer to `FS_ErrorNo2Text()`.

Additional information

This function performs the same operation as `FS_STORAGE_GetAutoMountType()` with the difference that the volume is specified via a volume instance instead of a volume name.

This function is available only if the file system is built with `FS_STORAGE_SUPPORT_MOUNT` set to 1.

4.12.16 FS_STORAGE_GetCleanCnt()

Description

Calculates the number of garbage collection sub-operations.

Prototype

```
int FS_STORAGE_GetCleanCnt(const char * sVolumeName,
                          U32 * pCleanCnt);
```

Parameters

Parameter	Description
<code>sVolumeName</code>	Name of the volume to be queried.
<code>pCleanCnt</code>	out Number of sub-operations left.

Return value

= 0 OK, clean count returned.
 ≠ 0 Error code indicating the failure reason.

Additional information

`FS_STORAGE_GetCleanCnt()` calculates and returns the number of sub-operations that the application has to perform until the garbage collection operation is completed. The value returned via `pCleanCnt` is the number of times `FS_STORAGE_CleanOne()` has to be called to complete the garbage collection. `FS_STORAGE_GetCleanCnt()` is supported only for volumes mounted on a storage device managed by emFile such as NAND or NOR flash.

Example

```
#include "FS.h"

void SampleStorageGetCleanCnt(void) {
    U32 CleanCnt;

    CleanCnt = 0;
    FS_STORAGE_GetCleanCnt("nor:0:", &CleanCnt);
    if (CleanCnt) {
        do {
            FS_STORAGE_CleanOne("nor:0:", NULL);
        } while (--CleanCnt);
    }
}
```

4.12.17 FS_STORAGE_GetCleanCntEx()

Description

Calculates the number of garbage collection sub-operations.

Prototype

```
int FS_STORAGE_GetCleanCntEx(FS_VOLUME * pVolume,  
                             U32      * pCleanCnt);
```

Parameters

Parameter	Description
<code>pVolume</code>	Instance of the volume to be queried.
<code>pCleanCnt</code>	<code>out</code> Number of sub-operations left.

Return value

= 0 OK, clean count returned.
≠ 0 Error code indicating the failure reason.

Additional information

This function performs the same operation as `FS_STORAGE_GetCleanCnt()` with the difference that the volume is specified via a volume instance instead of a volume name.

4.12.18 FS_STORAGE_GetCounters()

Description

Returns the values of statistical counters.

Prototype

```
void FS_STORAGE_GetCounters(FS_STORAGE_COUNTERS * pStat);
```

Parameters

Parameter	Description
pStat	out Current values of statistical counters.

Additional information

This function returns the values of the counters that indicate how many operations the storage layer executed since the file system initialization or the last call to `FS_STORAGE_ResetCounters()`.

The statistical counters are updated only on debug builds if the file system sources are compiled with `FS_DEBUG_LEVEL` greater than or equal to `FS_DEBUG_LEVEL_CHECK_PARA` or `FS_STORAGE_ENABLE_STAT_COUNTERS` set to 1.

Example

```
#include <stdio.h>
#include "FS.h"

void SampleStorageGetCounters(void) {
    FS_STORAGE_COUNTERS StatCnt;
    char ac[100];

    FS_STORAGE_GetCounters(&StatCnt);
    SEGGER_sprintf(ac, sizeof(ac), "Num. read operations: %lu\n",
        StatCnt.ReadOperationCnt);
    FS_X_Log(ac);
    SEGGER_sprintf(ac, sizeof(ac), "Num. sectors read: %lu\n",
        StatCnt.ReadSectorCnt);
    FS_X_Log(ac);
    SEGGER_sprintf(ac, sizeof(ac), "Num. sectors read (from cache): %lu\n",
        StatCnt.ReadSectorCachedCnt);
    FS_X_Log(ac);
    SEGGER_sprintf(ac, sizeof(ac), "Num. sectors read (alloc. table): %lu\n",
        StatCnt.ReadSectorCntMan);
    FS_X_Log(ac);
    SEGGER_sprintf(ac, sizeof(ac), "Num. sectors read (dir. entry): %lu\n",
        StatCnt.ReadSectorCntDir);
    FS_X_Log(ac);
    SEGGER_sprintf(ac, sizeof(ac), "Num. write operations: %lu\n",
        StatCnt.WriteOperationCnt);
    FS_X_Log(ac);
    SEGGER_sprintf(ac, sizeof(ac), "Num. sectors written: %lu\n",
        StatCnt.WriteSectorCnt);
    FS_X_Log(ac);
    SEGGER_sprintf(ac, sizeof(ac), "Num. sectors written (by cache): %lu\n",
        StatCnt.WriteSectorCntCleaned);
    FS_X_Log(ac);
    SEGGER_sprintf(ac, sizeof(ac), "Num. sectors written (alloc. table): %lu\n",
        StatCnt.WriteSectorCntMan);
    FS_X_Log(ac);
    SEGGER_sprintf(ac, sizeof(ac), "Num. sectors written (dir. entry): %lu\n",
        StatCnt.WriteSectorCntDir);
    FS_X_Log(ac);
}
```

4.12.19 FS_STORAGE_GetDeviceInfo()

Description

Returns information about the storage device.

Prototype

```
int FS_STORAGE_GetDeviceInfo(const char * sVolumeName,
                             FS_DEV_INFO * pDeviceInfo);
```

Parameters

Parameter	Description
<code>sVolumeName</code>	Name of the volume to be queried. It cannot be <code>NULL</code> .
<code>pDeviceInfo</code>	out Information about the storage device. It cannot be <code>NULL</code> .

Return value

= 0 OK, information returned.
 ≠ 0 Error code indicating the failure reason.

Additional information

This function returns information about the logical organization of the storage device such as the number of logical sectors and the size of the logical sector supported. `FS_STORAGE_GetDeviceInfo()` requests the information directly from the device driver.

Deprecated name

`FS_GetDeviceInfo`

Example

```
#include <stdio.h>
#include "FS.h"

void SampleStorageGetDeviceInfo(void) {
    FS_DEV_INFO DeviceInfo;
    char ac[100];

    FS_STORAGE_GetDeviceInfo("", &DeviceInfo);
    SEGGER_sprintf(ac, sizeof(ac), "Total num. sectors: %lu\n",
        DeviceInfo.NumSectors);
    FS_X_Log(ac);
    SEGGER_sprintf(ac, sizeof(ac), "Num. bytes per sector: %d\n",
        DeviceInfo.BytesPerSector);
    FS_X_Log(ac);
    SEGGER_sprintf(ac, sizeof(ac), "Num. read / write heads: %d\n",
        DeviceInfo.NumHeads);
    FS_X_Log(ac);
    SEGGER_sprintf(ac, sizeof(ac), "Num. sectors per track: %d\n",
        DeviceInfo.SectorsPerTrack);
    FS_X_Log(ac);
}
```

4.12.20 FS_STORAGE_GetDeviceInfoEx()

Description

Returns information about the storage device.

Prototype

```
int FS_STORAGE_GetDeviceInfoEx(FS_VOLUME * pVolume,  
                               FS_DEV_INFO * pDeviceInfo);
```

Parameters

Parameter	Description
<code>pVolume</code>	Instance of the volume to be queried.
<code>pDeviceInfo</code>	<code>out</code> Information about the storage device.

Return value

- = 0 OK, volume information returned.
- ≠ 0 Error code indicating the failure reason.

Additional information

This function performs the same operation as `FS_STORAGE_GetDeviceInfo()` with the difference that the volume to be queried is identified by a volume instance instead a volume name. The application can get a volume instance from a volume name by calling `FS_STORAGE_FindVolume()`.

4.12.21 FS_STORAGE_GetMountType()

Description

Returns information about how a volume is mounted.

Prototype

```
int FS_STORAGE_GetMountType(const char * sVolumeName);
```

Parameters

Parameter	Description
<code>sVolumeName</code>	Name of the volume to be queried.

Return value

= 0 Volume is not mounted.
= FS_MOUNT_RO Volume is mounted read only.
= FS_MOUNT_RW Volume is mounted read/write.
< 0 Error code indicating the failure reason. Refer to `FS_ErrorNo2Text()`.

Additional information

This function is available only if the file system is built with `FS_STORAGE_SUPPORT_MOUNT` set to 1.

4.12.22 FS_STORAGE_GetMountTypeEx()

Description

Returns information about how a volume is mounted.

Prototype

```
int FS_STORAGE_GetMountTypeEx(FS_VOLUME * pVolume);
```

Parameters

Parameter	Description
<code>pVolume</code>	Instance of the volume to be queried.

Return value

= 0 Volume is not mounted.
 = FS_MOUNT_RO Volume is mounted read only.
 = FS_MOUNT_RW Volume is mounted read/write.
 < 0 Error code indicating the failure reason. Refer to `FS_ErrorNo2Text()`.

Additional information

This function performs the same operation as `FS_STORAGE_GetMountType()` with the difference that the volume is specified via a volume instance instead of a volume name.

This function is available only if the file system is built with `FS_STORAGE_SUPPORT_MOUNT` set to 1.

4.12.23 FS_STORAGE_GetSectorUsage()

Description

Returns information about the usage of a logical sector.

Prototype

```
int FS_STORAGE_GetSectorUsage(const char * sVolumeName,
                             U32      SectorIndex);
```

Parameters

Parameter	Description
<code>sVolumeName</code>	Name of the volume.
<code>SectorIndex</code>	Index of the sector to be queried.

Return value

= FS_SECTOR_IN_USE	The sector contains valid data.
= FS_SECTOR_NOT_USED	The sector contains invalid data.
= FS_SECTOR_USAGE_UNKNOWN	The usage of the sector is unknown or the operation is not supported.
< 0	Error code indicating the failure reason.

Additional information

After a low-level format all the logical sectors contain invalid information. The data of a logical sector becomes valid after the application performs a write operation to that sector. The sector data can be explicitly invalidated by calling `FS_STORAGE_FreeSectors()`.

Example

```
#include "FS.h"

void SampleStorageGetSectorUsage(void) {
    int SectorUsage;

    SectorUsage = FS_STORAGE_GetSectorUsage("", 7);
    switch (SectorUsage) {
        case FS_SECTOR_IN_USE:
            FS_X_Log("The sector is used to store data.\n");
            break;
        case FS_SECTOR_NOT_USED:
            FS_X_Log("The sector is not used to store data.\n");
            break;
        case FS_SECTOR_USAGE_UNKNOWN:
            FS_X_Log("The sector usage is unknown.\n");
            break;
        default:
            FS_X_Log("An error occurred during the operation.\n");
    }
}
```

4.12.24 FS_STORAGE_GetSectorUsageEx()

Description

Returns information about the usage of a logical sector.

Prototype

```
int FS_STORAGE_GetSectorUsageEx(FS_VOLUME * pVolume,
                                U32       SectorIndex);
```

Parameters

Parameter	Description
<code>pVolume</code>	Instance of the volume that stores the logical sector.
<code>SectorIndex</code>	Index of the sector to be queried.

Return value

= FS_SECTOR_IN_USE	The sector contains valid data.
= FS_SECTOR_NOT_USED	The sector contains invalid data.
= FS_SECTOR_USAGE_UNKNOWN	The usage of the sector is unknown or the operation is not supported.
< 0	Error code indicating the failure reason.

Additional information

This function performs the same operation as `FS_STORAGE_GetSectorUsage()` with the difference that the volume is specified via a volume instance instead of a volume name.

4.12.25 FS_STORAGE_GetVolumeStatusEx()

Description

Returns the presence status of a volume.

Prototype

```
int FS_STORAGE_GetVolumeStatusEx(FS_VOLUME * pVolume);
```

Parameters

Parameter	Description
<code>pVolume</code>	Instance of the volume to be queried.

Return value

<code>FS_MEDIA_NOT_PRESENT</code>	Volume is not present.
<code>FS_MEDIA_IS_PRESENT</code>	Volume is present.
<code>FS_MEDIA_STATE_UNKNOWN</code>	Volume presence state is unknown.

Additional information

This function performs the same operation as `FS_GetVolumeStatus()` with the difference that the volume to be queried is identified by a volume instance instead a volume name. The application can get a volume instance from a volume name by calling `FS_STORAGE_FindVolume()`.

4.12.26 FS_STORAGE_Init()

Description

Initializes the storage layer.

Prototype

```
unsigned FS_STORAGE_Init(void);
```

Return value

Number of OS synchronization objects required to protect the file system against concurrent access from different tasks.

Additional information

This function initializes the only drivers and if necessary the OS layer. It has to be called before any other function of the storage layer (`FS_STORAGE_...`). The storage layer allows an application to access the file system at logical sector level. The storage device is presented as an array of logical sector that can be accessed via a 0-based index. This can be useful when using the file system as USB mass storage client driver.

`FS_STORAGE_Init()` is called internally at the initialization of the file system. The return value of this function is used by `FS_Init()` to calculate the number of internal buffers the file system has to allocate for the read and write operations. The application is not required to call `FS_STORAGE_Init()` if it already calls `FS_Init()`.

`FS_STORAGE_DeInit()` is the counterpart of `FS_STORAGE_Init()` that can be used to free the resources allocated by the drivers and if enabled of the OS layer.

Deprecated name

`FS_InitStorage`

Example

```
#include "FS.h"

void SampleStorageInit(void) {
    FS_STORAGE_Init();
    //
    // Access logical sectors...
    //
}
```

4.12.27 FS_STORAGE_IsLLFormattedEx()

Description

Checks if a storage device is low-level formatted.

Prototype

```
int FS_STORAGE_IsLLFormattedEx(FS_VOLUME * pVolume);
```

Parameters

Parameter	Description
<code>pVolume</code>	Instance of the volume to be queried.

Return value

= 1 Volume is low level formatted.
= 0 Volume is not low level formatted.
< 0 Low level format not supported by volume or an error occurred.

Additional information

This function performs the same operation as `FS_IsLLFormatted()` with the difference that the volume to be queried is identified by a volume instance instead a volume name. The application can get a volume instance from a volume name by calling `FS_STORAGE_FindVolume()`.

4.12.28 FS_STORAGE_Mount()

Description

Initializes a volume in a specified access mode.

Prototype

```
int FS_STORAGE_Mount(const char * sVolumeName,
                    U8      MountType);
```

Parameters

Parameter	Description
<code>sVolumeName</code>	Name of the volume to be mounted.
<code>MountType</code>	Specifies how the volume has to be mounted. <ul style="list-style-type: none"> • <code>FS_MOUNT_RO</code> Read only access mode. • <code>FS_MOUNT_RW</code> Read and write access mode.

Return value

= 0 Volume is not mounted.
= `FS_MOUNT_RO` Volume is mounted read only mode.
= `FS_MOUNT_RW` Volume is mounted read and write mode.
< 0 Error code indicating the failure reason.

Additional information

The application is not required to call this function before the first access to the storage device. The file system mounts by default the storage device at the first access after the file system initialization. This behavior can be configured via `FS_SetAutoMount()`.

A mounted volume can be unmounted via `FS_STORAGE_Unmount()` or `FS_STORAGE_UnmountForced()`.

4.12.29 FS_STORAGE_MountEx()

Description

Initializes a volume in a specified access mode.

Prototype

```
int FS_STORAGE_MountEx(FS_VOLUME * pVolume,
                       U8          MountType);
```

Parameters

Parameter	Description
<code>pVolume</code>	Instance of the volume to be mounted.
<code>MountType</code>	Specifies how the volume has to be mounted. <ul style="list-style-type: none"> • <code>FS_MOUNT_RO</code> Read only access mode. • <code>FS_MOUNT_RW</code> Read and write access mode.

Return value

= 0 Volume is not mounted.
= `FS_MOUNT_RO` Volume is mounted read only mode.
= `FS_MOUNT_RW` Volume is mounted read and write mode.
< 0 Error code indicating the failure reason.

Additional information

This function performs the same operation as `FS_STORAGE_Mount()` with the difference that the volume is specified via a volume instance instead of a volume name.

4.12.30 FS_STORAGE_ReadSector()

Description

Reads the data of one logical sector.

Prototype

```
int FS_STORAGE_ReadSector(const char * sVolumeName,
                          void * pData,
                          U32 SectorIndex);
```

Parameters

Parameter	Description
<code>sVolumeName</code>	Name of the volume to read from. It cannot be <code>NULL</code> .
<code>pData</code>	<code>out</code> Buffer that receives the read sector data. It cannot be <code>NULL</code> .
<code>SectorIndex</code>	Index of the sector to read from.

Return value

= 0 OK, sector data read.
 ≠ 0 Error code indicating the failure reason.

Additional information

`pData` has to point to a memory region sufficiently large to store the contents of one logical sector.

The size of the logical sector depends on the type of storage device used. The application can query the size of the logical sector as well as the number of logical sectors of a storage device via `FS_STORAGE_GetDeviceInfo()`. Typically, the size of a logical sector is 512 bytes.

`FS_STORAGE_ReadSector()` reports an error and does not store any data to `pData` if `SectorIndex` is out of bounds.

The application can call `FS_STORAGE_ReadSectors()` instead of calling `FS_STORAGE_ReadSector()` multiple times if it has to read consecutive logical sectors at once.

Deprecated name

`FS_ReadSector`

Example

```
#include "FS.h"

void SampleStorageReadSector(void) {
    U32 aSectorData[512 / 4];

    //
    // Read the data of the logical sector with the index 10.
    //
    FS_STORAGE_ReadSector("", aSectorData, 10);
}
```

4.12.31 FS_STORAGE_ReadSectorEx()

Description

Reads the contents of one logical sector from the storage device.

Prototype

```
int FS_STORAGE_ReadSectorEx(FS_VOLUME * pVolume,
                           void * pData,
                           U32 SectorIndex);
```

Parameters

Parameter	Description
<code>pVolume</code>	Instance of the volume to read from.
<code>pData</code>	out Contents of the logical sector.
<code>SectorIndex</code>	Index of the logical sector to be read.

Return value

= 0 OK, logical sector read successfully.
 ≠ 0 Error code indicating the failure reason.

Additional information

This function performs the same operation as `FS_STORAGE_ReadSector()` with the difference that the volume is specified via a volume instance instead a volume name. The application can get a volume instance from a volume name by calling `FS_STORAGE_FindVolume()` or `FS_STORAGE_FindVolumeByIndex()`.

4.12.32 FS_STORAGE_ReadSectors()

Description

Reads the data of one or more logical sectors.

Prototype

```
int FS_STORAGE_ReadSectors(const char * sVolumeName,
                          void * pData,
                          U32 SectorIndex,
                          U32 NumSectors);
```

Parameters

Parameter	Description
<code>sVolumeName</code>	Name of the volume to read from. It cannot be <code>NULL</code> .
<code>pData</code>	out Buffer that receives the read sector data. It cannot be <code>NULL</code> .
<code>SectorIndex</code>	Index of the first sector to read from.
<code>NumSectors</code>	Number of sectors to be read.

Return value

= 0 OK, sector data read.
 ≠ 0 Error code indicating the failure reason.

Additional information

This function can be used to read the contents of multiple consecutive logical sectors. `pData` has to point to a memory region sufficiently large to store the contents of all logical sectors read.

The size of the logical sector depends on the type of storage device used. The application can query the size of the logical sector as well as the number of logical sectors of a storage device via `FS_STORAGE_GetDeviceInfo()`. Typically, the size of a logical sector is 512 bytes.

`FS_STORAGE_ReadSectors()` reports an error and does not perform any operation if the specified range of logical sectors exceeds the size of the storage device.

Example

```
#include "FS.h"

void SampleStorageReadSectors(void) {
    U32 aSectorData[512 * 2 / 4];

    //
    // Read the data of the logical sectors with the indexes 10 and 11.
    //
    FS_STORAGE_ReadSectors("", aSectorData, 10, 2);
}
```

4.12.33 FS_STORAGE_ReadSectorsEx()

Description

Reads the contents of multiple logical sectors from a storage device.

Prototype

```
int FS_STORAGE_ReadSectorsEx(FS_VOLUME * pVolume,
                             void      * pData,
                             U32       SectorIndex,
                             U32       NumSectors);
```

Parameters

Parameter	Description
<code>pVolume</code>	Instance of the volume to read from.
<code>pData</code>	out Contents of the logical sector.
<code>SectorIndex</code>	Index of the logical sector to be read.
<code>NumSectors</code>	Number of logical sectors to be read.

Return value

= 0 OK, logical sectors read successfully.
 ≠ 0 Error code indicating the failure reason

Additional information

This function performs the same operation as `FS_STORAGE_ReadSectors()` with the difference that the volume is specified via a volume instance instead a volume name. The application can get a volume instance from a volume name by calling `FS_STORAGE_FindVolume()` or `FS_STORAGE_FindVolumeByIndex()`.

4.12.34 FS_STORAGE_RefreshSectors()

Description

Reads the contents of a logical sector and writes it back.

Prototype

```
int FS_STORAGE_RefreshSectors(const char * sVolumeName,
                             U32      SectorIndex,
                             U32      NumSectors,
                             void *  pBuffer,
                             U32      NumBytes);
```

Parameters

Parameter	Description
<code>sVolumeName</code>	Name of the volume on which to perform the operation. It cannot be NULL.
<code>SectorIndex</code>	Index of the first sector to refresh (0-based).
<code>NumSectors</code>	Number of sectors to refresh starting with <code>SectorIndex</code> .
<code>pBuffer</code>	Temporary storage for the sector data. Must be at least one sector large. It cannot be NULL.
<code>NumBytes</code>	Number of bytes in <code>pBuffer</code> .

Return value

= 0 OK, sectors refreshed.
 ≠ 0 Error code indicating the failure reason

Additional information

This function reads the contents of each specified logical sector to `pBuffer` and then it writes the same data to it. `FS_STORAGE_RefreshSectors()` can read and write more than one logical sector at once if the size of `pBuffer` allows it. The larger `pBuffer` the faster runs the refresh operation.

`FS_STORAGE_RefreshSectors()` function can be used on volumes mounted on a NAND flash device to prevent the accumulation of bit errors due to excessive read operations (read disturb effect). The function can also be used to prevent data losses caused by the data reaching the retention limit. Reading and then writing back the contents of a logical sector causes the NAND driver to relocate the data on the NAND flash device that in turn eliminates bit errors. Typically, the refresh operation has to be performed periodically at large time intervals (weeks). The NAND flash may wear out too soon if the refresh operation is performed too often.

Example

```
#include "FS.h"

static U32 _aBuffer[2048 * 2 / 4];

void SampleStorageRefreshSectors(void) {
    //
    // Refresh the logical sectors with the indexes 10-99
    // stored on the NAND flash.
    //
    FS_STORAGE_RefreshSectors("nand:0:", 10, 100, _aBuffer, sizeof(_aBuffer));
}
```

4.12.35 FS_STORAGE_RefreshSectorsEx()

Description

Reads the contents of a logical sector and writes it back.

Prototype

```
int FS_STORAGE_RefreshSectorsEx(FS_VOLUME * pVolume,
                                U32       SectorIndex,
                                U32       NumSectors,
                                void      * pBuffer,
                                U32       NumBytes);
```

Parameters

Parameter	Description
<code>pVolume</code>	Instance of the volume on which to perform the operation. It cannot be <code>NULL</code> .
<code>SectorIndex</code>	Index of the first sector to refresh (0-based).
<code>NumSectors</code>	Number of sectors to refresh starting with <code>SectorIndex</code> .
<code>pBuffer</code>	Temporary storage for the sector data. Must be at least one sector large. It cannot be <code>NULL</code> .
<code>NumBytes</code>	Number of bytes in <code>pBuffer</code> .

Return value

= 0 OK, sectors refreshed.
 ≠ 0 Error code indicating the failure reason

Additional information

This function performs the same operation as `FS_STORAGE_RefreshSectors()` with the difference that the volume is specified via a volume instance instead of a volume name.

4.12.36 FS_STORAGE_ResetCounters()

Description

Sets all statistical counters to 0.

Prototype

```
void FS_STORAGE_ResetCounters(void);
```

Additional information

This function can be used to set to 0 all the statistical counters maintained by the storage layer. This can be useful for example in finding out how many sector operations are performed during a specific file system operation. The application calls `FS_STORAGE_ResetCounters()` before the file system operation and then `FS_STORAGE_GetCounters()` at the end.

The statistical counters are available only on debug builds if the file system sources are compiled with `FS_DEBUG_LEVEL` greater than or equal to `FS_DEBUG_LEVEL_CHECK_PARA` or `FS_STORAGE_ENABLE_STAT_COUNTERS` set to 1.

Example

```
#include "FS.h"

void SampleStorageResetCounters(void) {
    FS_STORAGE_COUNTERS StatCnt;

    //
    // Set all statistical counters to 0.
    //
    FS_STORAGE_ResetCounters();

    //
    // Perform the file system operation...
    //

    //
    // Check the statistical counters.
    //
    FS_STORAGE_GetCounters(&StatCnt);
}
```

4.12.37 FS_STORAGE_SetAutoMountType()

Description

Sets the automatic mount behavior.

Prototype

```
int FS_STORAGE_SetAutoMountType(const char * sVolumeName,  
                                U8      MountType);
```

Parameters

Parameter	Description
<code>sVolumeName</code>	Name of the volume to be configured.
<code>MountType</code>	Specifies how the volume has to be mounted. <ul style="list-style-type: none">• <code>FS_MOUNT_RO</code> Allows to automatically mount the volume in read only mode.• <code>FS_MOUNT_RW</code> Allows to automatically mount the volume in read and write mode.• <code>0</code> Disables the automatic mount operation for the volume.

Additional information

This function is available only if the file system is built with `FS_STORAGE_SUPPORT_MOUNT` set to 1.

4.12.38 FS_STORAGE_SetAutoMountTypeEx()

Description

Sets the automatic mount behavior.

Prototype

```
int FS_STORAGE_SetAutoMountTypeEx(FS_VOLUME * pVolume,
                                  U8          MountType);
```

Parameters

Parameter	Description
<code>pVolume</code>	Instance of the volume to be configured.
<code>MountType</code>	Specifies how the volume has to be mounted. <ul style="list-style-type: none"> • <code>FS_MOUNT_RO</code> Allows to automatically mount the volume in read only mode. • <code>FS_MOUNT_RW</code> Allows to automatically mount the volume in read and write mode. • <code>0</code> Disables the automatic mount operation for the volume.

Additional information

This function performs the same operation as `FS_STORAGE_SetAutoMount()` with the difference that the volume is specified via a volume instance instead of a volume name.

This function is available only if the file system is built with `FS_STORAGE_SUPPORT_MOUNT` set to 1.

4.12.39 FS_STORAGE_SetOnDeviceActivityCallback()

Description

Registers a function to be called on any logical sector read or write operation.

Prototype

```
void FS_STORAGE_SetOnDeviceActivityCallback
    (const char * sVolumeName,
     FS_ON_DEVICE_ACTIVITY_CALLBACK * pfOnDeviceActivity);
```

Parameters

Parameter	Description
<code>sVolumeName</code>	Name of the volume for which the callback function is registered. It cannot be NULL.
<code>pfOnDeviceActivity</code>	Function to be invoked.

Additional information

This function is optional. It is available only when the file system is built with `FS_DEBUG_LEVEL` set to a value greater than or equal to `FS_DEBUG_LEVEL_CHECK_PARA` or with `FS_STORAGE_SUPPORT_DEVICE_ACTIVITY` set to 1.

Example

Refer to the sample application `FS_DeviceActivity.c` located in the `Sample/FS/Application` folder of the emFile shipment.

4.12.40 FS_STORAGE_Sync()

Description

Writes cached information to storage device.

Prototype

```
void FS_STORAGE_Sync(const char * sVolumeName);
```

Parameters

Parameter	Description
<code>sVolumeName</code>	Name of the volume to be synchronized.

Additional information

This function updates all the information present only in sector cache (if enabled) to storage device. It also requests the driver to perform a synchronization operation. The operations performed during the synchronization are driver-dependent.

Typically, `FS_STORAGE_Sync()` has to be called if a write-back sector cache is configured for the volume to reduce the chance of a data loss in case of an unexpected reset.

Deprecated name

`FS_CleanVolume`

Example

```
#include <string.h>
#include "FS.h"

void SampleStorageSync(void) {
    U32 aSectorData[512 / 4];

    memset(aSectorData, 'a', sizeof(aSectorData));
    //
    // Write some data to sector with the index 0.
    //
    FS_STORAGE_WriteSector("", aSectorData, 0);
    //
    // Make sure that the data is written to storage device.
    //
    FS_STORAGE_Sync("");
}
```

4.12.41 FS_STORAGE_SyncEx()

Description

Writes cached information to storage device.

Prototype

```
int FS_STORAGE_SyncEx(FS_VOLUME * pVolume);
```

Parameters

Parameter	Description
<code>pVolume</code>	Instance of the volume to be synchronized.

Return value

= 0 OK, volume synchronized successfully.
≠ 0 Error code indicating the failure reason.

Additional information

This function performs the same operation as `FS_STORAGE_Sync()` with the difference that the volume to be synchronized is identified by a volume instance instead of a volume name.

4.12.42 FS_STORAGE_SyncSectors()

Description

Synchronizes the contents of one or more logical sectors.

Prototype

```
int FS_STORAGE_SyncSectors(const char * sVolumeName,
                          U32      SectorIndex,
                          U32      NumSectors);
```

Parameters

Parameter	Description
<code>sVolumeName</code>	Name of the volume that stores the logical sectors.
<code>SectorIndex</code>	Index of the first sector to be synchronized (0-based).
<code>NumSectors</code>	Number of sectors to be synchronized starting with <code>SectorIndex</code> .

Return value

= 0 OK, sectors synchronized.
 ≠ 0 Error code indicating the failure reason.

Additional information

This operation is driver-dependent and is currently supported only by the RAID1 logical driver. The operation updates the contents of the specified logical sectors that are located on the secondary storage (mirrored) with the contents of the corresponding logical sectors from the primary storage (master). RAID1 logical driver updates the logical sectors only if the contents is different.

Example

```
#include "FS.h"

void SampleStorageSyncSectors(void) {
    //
    // Synchronizes the logical sectors with the indexes 7, 8 and 9.
    //
    FS_STORAGE_SyncSectors("", 7, 3);
}
```

4.12.43 FS_STORAGE_SyncSectorsEx()

Description

Synchronizes the contents of one or more logical sectors.

Prototype

```
int FS_STORAGE_SyncSectorsEx(FS_VOLUME * pVolume,
                             U32       SectorIndex,
                             U32       NumSectors);
```

Parameters

Parameter	Description
<code>pVolume</code>	Instance of the volume that stores the logical sectors.
<code>SectorIndex</code>	Index of the first sector to be synchronized (0-based).
<code>NumSectors</code>	Number of sectors to be synchronized starting with <code>SectorIndex</code> .

Return value

= 0 OK, sectors synchronized.
 ≠ 0 Error code indicating the failure reason.

Additional information

This function performs the same operation as `FS_STORAGE_SyncSectors()` with the difference that the volume is specified via a volume instance instead of a volume name.

4.12.44 FS_STORAGE_Unmount()

Description

Synchronizes a volume and marks it as not initialized.

Prototype

```
void FS_STORAGE_Unmount(const char * sVolumeName);
```

Parameters

Parameter	Description
<code>sVolumeName</code>	Name of the volume to be unmounted. It cannot be <code>NULL</code> .

Additional information

The function sends an unmount command to the driver and marks the volume as unmounted and uninitialized. If a write sector cache is enabled, `FS_STORAGE_Unmount()` also stores any modified data from sector cache to storage device. This function has to be called before the device is shutdown to prevent a data loss.

The file system mounts automatically the volume at the call to an API function of the storage layer.

Deprecated name

`FS_UnmountLL`

Example

```
#include "FS.h"

void SampleStorageUnmount(void) {
    //
    // Synchronize the sector cache and mark the volume as not initialized.
    //
    FS_STORAGE_Unmount("");
    //
    // The device can be shutdown here without loosing any data.
    //
}
```

4.12.45 FS_STORAGE_UnmountEx()

Description

Synchronizes the volume and marks it as not initialized.

Prototype

```
void FS_STORAGE_UnmountEx(FS_VOLUME * pVolume);
```

Parameters

Parameter	Description
<code>pVolume</code>	Instance of the volume to be unmounted.

Additional information

This function performs the same operation as `FS_STORAGE_Unmount()` with the difference that the volume is specified via a volume instance instead a volume name. The application can get a volume instance from a volume name by calling `FS_STORAGE_FindVolume()` or `FS_STORAGE_FindVolumeByIndex()`.

4.12.46 FS_STORAGE_UnmountForced()

Description

Marks a volume it as not initialized.

Prototype

```
void FS_STORAGE_UnmountForced(const char * sVolumeName);
```

Parameters

Parameter	Description
<code>sVolumeName</code>	Name of the volume to be unmounted. It cannot be NULL.

Additional information

This function performs the same operations as `FS_STORAGE_Unmount()`. `FS_STORAGE_UnmountForced()` has to be called if a storage device has been removed before being regularly unmounted. When using `FS_STORAGE_UnmountForced()` there is no guarantee that the information cached by the file system is updated to storage.

The file system mounts automatically the volume at the call to an API function of the storage layer.

Example

```
#include "FS.h"

void SampleStorageUnmountForced(void) {
    if (FS_GetVolumeStatus("") == FS_MEDIA_IS_PRESENT) {
        //
        // Synchronize the sector cache and mark the volume as not initialized.
        //
        FS_STORAGE_Unmount("");
        //
        // The device can be shutdown here without loosing any data.
        //
    } else {
        //
        // Storage device has been removed. Mark the volume as not initialized.
        // Data loss is possible.
        //
        FS_STORAGE_UnmountForced("");
    }
}
```

4.12.47 FS_STORAGE_UnmountForcedEx()

Description

Marks the volume as not initialized without synchronizing it.

Prototype

```
void FS_STORAGE_UnmountForcedEx(FS_VOLUME * pVolume);
```

Parameters

Parameter	Description
<code>pVolume</code>	Instance of the volume to be unmounted.

Additional information

This function performs the same operation as `FS_STORAGE_UnmountForced()` with the difference that the volume is specified via a volume instance instead a volume name. The application can get a volume instance from a volume name by calling `FS_STORAGE_FindVolume()`.

4.12.48 FS_STORAGE_WriteSector()

Description

Modifies the data of a logical sector.

Prototype

```
int FS_STORAGE_WriteSector(const char * sVolumeName,
                          const void * pData,
                          U32      SectorIndex);
```

Parameters

Parameter	Description
<code>sVolumeName</code>	Name of the volume to write to. It cannot be NULL.
<code>pData</code>	in Buffer that contains the sector data to be written. It cannot be NULL.
<code>SectorIndex</code>	Index of the sector to write to.

Return value

= 0 OK, sector data modified.
 ≠ 0 Error code indicating the failure reason.

Additional information

`pData` has to point to a memory region that stores the contents of one logical sector.

The size of the logical sector depends on the type of storage device used. The application can query the size of the logical sector as well as the number of logical sectors of a storage device via `FS_STORAGE_GetDeviceInfo()`. Typically, the size of a logical sector is 512 bytes.

`FS_STORAGE_WriteSector()` reports an error and does not modify the contents of the logical sector if `SectorIndex` is out of bounds.

The application can call `FS_STORAGE_WriteSectors()` instead of calling `FS_STORAGE_WriteSector()` multiple times if it has to write consecutive logical sectors at once.

Deprecated name

`FS_WriteSector`

Example

```
#include <string.h>
#include "FS_Storage.h"

void SampleStorageWriteSector(void) {
    U32 aSectorData[512 / 4];

    memset(aSectorData, 'a', sizeof(aSectorData));
    //
    // Write the data of the logical sector with the index 7.
    //
    FS_STORAGE_WriteSector("", aSectorData, 7);
}
```

4.12.49 FS_STORAGE_WriteSectorEx()

Description

Writes a logical sector to the storage device.

Prototype

```
int FS_STORAGE_WriteSectorEx(    FS_VOLUME * pVolume,  
                                const void * pData,  
                                U32      SectorIndex);
```

Parameters

Parameter	Description
<code>pVolume</code>	Instance of the volume to write to.
<code>pData</code>	<code>in</code> Contents of the logical sector.
<code>SectorIndex</code>	Index of the logical sector to be written.

Return value

= 0 OK, logical sector written successfully.
≠ 0 Error code indicating the failure reason.

Additional information

This function performs the same operation as `FS_STORAGE_WriteSector()` with the difference that the volume is specified via a volume instance instead a volume name. The application can get a volume instance from a volume name by calling `FS_STORAGE_FindVolume()`.

4.12.50 FS_STORAGE_WriteSectors()

Description

Modifies the data of one or more logical sectors.

Prototype

```
int FS_STORAGE_WriteSectors(const char * sVolumeName,
                           const void * pData,
                           U32      SectorIndex,
                           U32      NumSectors);
```

Parameters

Parameter	Description
<code>sVolumeName</code>	Name of the volume to write to. It cannot be NULL.
<code>pData</code>	In Buffer that contains the sector data to be written. It cannot be NULL.
<code>SectorIndex</code>	Index of the first sector to be written.
<code>NumSectors</code>	Number of sectors to be written.

Return value

= 0 OK, sector data modified.
 ≠ 0 Error code indicating the failure reason.

Additional information

This function can be used to modify the contents of multiple consecutive logical sectors. `pData` has to point to a memory area that stores the contents of all the logical sectors to be written.

The size of the logical sector depends on the type of storage device used. The application can query the size of the logical sector as well as the number of logical sectors of a storage device via `FS_STORAGE_GetDeviceInfo()`. Typically, the size of a logical sector is 512 bytes.

`FS_STORAGE_WriteSectors()` reports an error and does not perform any operation if the specified range of logical sectors exceeds the size of the storage device.

Example

```
#include "FS.h"

void SampleStorageWriteSectors(void) {
    U32 aSectorData[512 / 4 * 2];

    //
    // Write the data of the logical sectors with the indexes 7 and 8.
    //
    FS_STORAGE_WriteSectors("", aSectorData, 7, 2);
}
```

4.12.51 FS_STORAGE_WriteSectorsEx()

Description

Writes multiple logical sectors to the storage device.

Prototype

```
int FS_STORAGE_WriteSectorsEx(    FS_VOLUME * pVolume,
                                const void * pData,
                                U32      SectorIndex,
                                U32      NumSectors);
```

Parameters

Parameter	Description
<code>pVolume</code>	Instance of the volume to write to.
<code>pData</code>	in Contents of the logical sector.
<code>SectorIndex</code>	Index of the logical sector to be written.
<code>NumSectors</code>	Number of logical sectors to be written.

Return value

= 0 OK, logical sectors written successfully.
 ≠ 0 Error code indicating the failure reason.

Additional information

This function performs the same operation as `FS_STORAGE_WriteSectors()` with the difference that the volume is specified via a volume instance instead a volume name. The application can get a volume instance from a volume name by calling `FS_STORAGE_FindVolume()`.

4.12.52 FS_DEV_INFO

Description

Information about the storage device.

Type definition

```
typedef struct {
    U16  NumHeads;
    U16  SectorsPerTrack;
    U32  NumSectors;
    U16  BytesPerSector;
} FS_DEV_INFO;
```

Structure members

Member	Description
NumHeads	Number of read / write heads.
SectorsPerTrack	Number of sectors stored on a track.
NumSectors	Total number of sectors on the storage device.
BytesPerSector	Size of a logical sector in bytes.

Additional information

[NumHeads](#) and [SectorsPerTrack](#) are relevant only for mechanical drives. The application can access the information about the storage device by calling `FS_STORAGE_GetDeviceInfo()`.

4.12.53 FS_ON_DEVICE_ACTIVITY_CALLBACK

Description

The type of the callback function invoked by the file system on a logical sector read or write operation.

Type definition

```
typedef void (FS_ON_DEVICE_ACTIVITY_CALLBACK)(FS_DEVICE * pDevice,
                                             unsigned Operation,
                                             U32 StartSector,
                                             U32 NumSectors,
                                             int SectorType);
```

Parameters

Parameter	Description
<code>pDevice</code>	Storage device that performed the operation.
<code>Operation</code>	Type of the operation performed. Can be one of the values listed in <i>Transfer direction</i> on page 310
<code>StartSector</code>	Index of the first logical sector transferred (0-based)
<code>NumSectors</code>	Number of logical sectors transferred in the current operation.
<code>SectorType</code>	Type of the data stored in the logical sector. It can be one of the values listed in <i>Sector data type</i> on page 309

Additional information

This is the type of function that can be registered via `FS_STORAGE_SetOnDeviceActivity-Callback()`

4.12.54 FS_STORAGE_COUNTERS

Description

Statistical counters.

Type definition

```
typedef struct {
    U32  ReadOperationCnt;
    U32  ReadSectorCnt;
    U32  ReadSectorCachedCnt;
    U32  WriteOperationCnt;
    U32  WriteSectorCnt;
    U32  WriteSectorCntCleaned;
    U32  ReadSectorCntMan;
    U32  ReadSectorCntDir;
    U32  WriteSectorCntMan;
    U32  WriteSectorCntDir;
} FS_STORAGE_COUNTERS;
```

Structure members

Member	Description
ReadOperationCnt	Number of "Read sector operation" calls.
ReadSectorCnt	Number of sectors read (before cache).
ReadSectorCachedCnt	Number of sectors read from cache
WriteOperationCnt	Number of "Write sector operation" calls
WriteSectorCnt	Number of sectors written (before cache).
WriteSectorCntCleaned	Number of sectors written by the cache to storage in order to make room for other data.
ReadSectorCntMan	Number of management sectors read (before cache).
ReadSectorCntDir	Number of directory sectors (which store directory entries) read (before cache).
WriteSectorCntMan	Number of management sectors written (before cache).
WriteSectorCntDir	Number of directory sectors (which store directory entries) written (before cache).

Additional information

[ReadSectorCnt](#) can be (and typically is) higher than [ReadOperationCnt](#), since one read operation can request multiple sectors (in a burst). The same applies to write operations: [WriteSectorCnt](#) can be (and typically is) higher than [WriteOperationCnt](#), since one read operation can request multiple sectors (in a burst).

The statistical counters can be read via `FS_STORAGE_GetCounters()`. They are set to 0 when the file system is initialized. Additionally, the application can explicitly set them to 0 via `FS_STORAGE_ResetCounters()`.

4.12.55 Sector data type

Description

Type of data stored in a logical sector

Definition

```
#define FS_SECTOR_TYPE_DATA    0u
#define FS_SECTOR_TYPE_DIR    1u
#define FS_SECTOR_TYPE_MAN    2u
```

Symbols

Definition	Description
FS_SECTOR_TYPE_DATA	Sector that stores file data.
FS_SECTOR_TYPE_DIR	Sector that stores directory entries.
FS_SECTOR_TYPE_MAN	Sector that stores entries of the allocation table.

4.12.56 Transfer direction

Description

Direction of the transferred data.

Definition

```
#define FS_OPERATION_READ      0
#define FS_OPERATION_WRITE    1
```

Symbols

Definition	Description
FS_OPERATION_READ	Data is transferred from storage device to MCU.
FS_OPERATION_WRITE	Data is transferred from MCU to storage device.

Additional information

One of these values is passed by the file system via Operation parameter to the callback function registered via `FS_STORAGE_SetOnDeviceActivityCallback()`

4.13 FAT related functions

The functions described in this section can be used only on volumes formatted as FAT.

4.13.1 FS_FAT_ConfigDirtyFlagUpdate()

Description

Enables / disables the update of the flag that indicates if the volume has been unmounted correctly.

Prototype

```
void FS_FAT_ConfigDirtyFlagUpdate(int OnOff);
```

Parameters

Parameter	Description
OnOff	Activation status of the option. <ul style="list-style-type: none"> • 0 Disable the option. • 1 Enable the option.

Additional information

If enabled, the file system updates an internal dirty flag that is set to 1 each time data is written to storage device. The dirty flag is set to 0 when the application unmounts the file system. The value of the dirty flag is updated to storage device and can be used to check if the storage device has been properly unmounted before the system reset. `FS_GetVolumeInfo()` can be used to get the value of this dirty flag (IsDirty member of `FS_DISK_INFO`).

The update of the dirty flag is enabled by default if the compile-time option `FS_FAT_UPDATE_DIRTY_FLAG` is set to 1. `FS_FAT_ConfigDirtyFlagUpdate()` is available only if the compile-time option `FS_FAT_UPDATE_DIRTY_FLAG` is set to 1.

Example

```
#include "FS.h"

void SampleFATConfigDirtyFlagUpdate(void) {
    FS_FILE      * pFile;
    FS_DISK_INFO VolumeInfo;

    FS_Init();
    #if FS_FAT_UPDATE_DIRTY_FLAG
        FS_FAT_ConfigDirtyFlagUpdate(1);
    #endif
    pFile = FS_FOpen("Test.txt", "w");
    if (pFile) {
        FS_FClose(pFile);
    }
    FS_GetVolumeInfo("", &VolumeInfo);
    if (VolumeInfo.IsDirty) {
        FS_X_Log("Volume has been modified.\n");
    } else {
        FS_X_Log("Volume has not been modified.\n");
    }
}
```

4.13.2 FS_FAT_ConfigFATCopyMaintenance()

Description

Enables / disables the update of the second allocation table.

Prototype

```
void FS_FAT_ConfigFATCopyMaintenance(int OnOff);
```

Parameters

Parameter	Description
OnOff	Activation status of the option. <ul style="list-style-type: none"> • 0 Disable the option. • 1 Enable the option.

Additional information

The FAT file system has support for a second (redundant) allocation table. `FS_FAT_ConfigFATCopyMaintenance()` can be used to enable or disable the update of the second allocation table. The data in the second allocation table is not used by the file system but it may be required to be present by some PC file system checking utilities. Enabling this option can possibly reduce the write performance of the file system.

The update of the second allocation table is enabled by default if the compile-time option `FS_MAINTAIN_FAT_COPY` is set to 1. `FS_FAT_ConfigFATCopyMaintenance()` is available only if the compile-time option `FS_MAINTAIN_FAT_COPY` is set to 1.

Example

```
#include "FS.h"

void SampleFATConfigFATCopyMaintenance(void) {
    FS_Init();
    #if FS_MAINTAIN_FAT_COPY
        FS_FAT_ConfigFATCopyMaintenance(1);
    #endif
    //
    // At each write access to the allocation table
    // the second allocation table is also updated.
    //
}
```

4.13.3 FS_FAT_ConfigFSInfoSectorUse()

Description

Enables / disables the usage of information from the FSInfo sector.

Prototype

```
void FS_FAT_ConfigFSInfoSectorUse(int OnOff);
```

Parameters

Parameter	Description
OnOff	Activation status of the option. <ul style="list-style-type: none"> • 0 Disable the option. • 1 Enable the option.

Additional information

FSInfo sector is a management sector present on FAT32-formatted volumes that stores information about the number of free clusters and the id of the first free cluster. This information, when available and valid, can be used to increase the performance of the operation that calculates the available free space on a volume such as `FS_GetVolumeFreeSpace()`, `FS_GetVolumeFreeSpaceKB()`, `FS_GetVolumeInfo()`, or `FS_GetVolumeInfoEx()`. If the information in the FSInfo sector is missing or invalid, the file system has to scan the entire allocation to calculate the available free space an operation that can take a long time to complete on storage devices with a large capacity (few Gbytes.)

The file system invalidates the information in the FSInfo sector on the first operation that allocates or frees a cluster. The FSInfo sector is updated when the volume is unmounted via `FS_Unmount()` or synchronized via `FS_Sync()`.

FSInfo sector is evaluated and updated by default if the compile-time option `FS_FAT_USE_FSINFO_SECTOR` is set to 1. `FS_FAT_ConfigFSInfoSectorUse()` is available only if the compile-time option `FS_FAT_USE_FSINFO_SECTOR` is set to 1.

Example

```
#include "FS.h"

void SampleFATConfigFSInfoSectorUse(void) {
    U32 NumBytes;

    FS_Init();
    #if FS_FAT_USE_FSINFO_SECTOR
        FS_FAT_ConfigFSInfoSectorUse(1);
    #endif
    NumBytes = FS_GetVolumeFreeSpace("");
}
```

4.13.4 FS_FAT_ConfigROFileMovePermission()

Description

Enables / disables the permission to move (and rename) files and directories with the read-only file attribute set.

Prototype

```
void FS_FAT_ConfigROFileMovePermission(int OnOff);
```

Parameters

Parameter	Description
OnOff	Activation status of the option. <ul style="list-style-type: none"> • 0 Disable the option. • 1 Enable the option.

Additional information

The application is per default allowed to move or rename via `FS_Move()` and `FS_Rename()` respectively files and directories that have the read-only file attribute (`FS_ATTR_READ_ONLY`) set. `FS_FAT_ConfigROFileMovePermission()` can be used to disable this option and thus to prevent an application to perform move or rename operations on files and directories marked as read-only.

`FS_FAT_ConfigROFileMovePermission()` is available only if the compile-time option `FS_FAT_PERMIT_RO_FILE_MOVE` is set to 1.

Example

```
#include "FS.h"

void SampleFATConfigROFileMovePermission(void) {
    FS_FILE * pFile;
    int      r;

    #if FS_FAT_PERMIT_RO_FILE_MOVE
        FS_FAT_ConfigROFileMovePermission(0);
    #endif
    pFile = FS_FOpen("Test.txt", "w");
    if (pFile != NULL) {
        FS_FClose(pFile);
    }
    FS_SetFileAttributes("Test.txt", FS_ATTR_READ_ONLY);
    r = FS_Move("Test.txt", "TestOld.txt");
    if (r != 0) {
        //
        // A file marked as read-only cannot be moved to another location.
        //
    }
}
```

4.13.5 FS_FAT_DisableLFN()

Description

Disables the support for long file names.

Prototype

```
void FS_FAT_DisableLFN(void);
```

Additional information

After calling this function the file system accepts only file and directory names in 8.3 format. Files and directories created with support for long file names enabled are still accessible since each long file name has an associated name in 8.3 format. The short name is automatically generated by the file system based on the first characters of the long name and a sequential index. The support for long file names can be activated via `FS_FAT_SupportLFN()`.

This function applies only to volumes formatted as FAT. EFS-formatted volumes have native support for long file names.

Example

```
#include "FS.h"

void SampleFATDisableLFN(void) {
    FS_FILE * pFile;

    FS_Init();
    #if FS_SUPPORT_FAT
        FS_FAT_DisableLFN();
    #endif
    pFile = FS_FOpen("FileName.txt", "w");
    if (pFile) {
        FS_FClose(pFile);
    }
}
```

4.13.6 FS_FAT_FormatSD()

Description

Formats the volume according to specification of SD Association.

Prototype

```
int FS_FAT_FormatSD(const char * sVolumeName);
```

Parameters

Parameter	Description
<code>sVolumeName</code>	Name of the volume to be formatted.

Return value

= 0 O.K., format successful.
 ≠ 0 Error code indicating the failure reason.

Additional information

The SD Association defines the layout of the information that has to be stored to an SD, SDHC or SDXC card during the FAT format operation to ensure the best read and write performance by taking advantage of the physical structure of the storage device. `FS_FAT_FormatSD()` implements this recommended layout and it shall be used to format SD and MMC storage devices but it can be used for other storage devices as well. It typically reserves more space for the file system as `FS_Format()` and as a consequence less space is available for the application to store files and directories.

`FS_FAT_FormatSD()` performs the following steps:

- Writes partition entry into the MBR.
- Formats the storage device as FAT.

The function is available only if the file system sources are compiled with the `FS_SUPPORT_FAT` option define set to 1.

Deprecated name

`FS_FormatSD`

Example

```
#include "FS.h"

void SampleFATFormatSD(void) {
    FS_Init();
    #if FS_SUPPORT_FAT
        FS_FAT_FormatSD("");
    #endif
}
```

4.13.7 FS_FAT_GetConfig()

Description

Returns information about how the FAT component is configured to operate.

Prototype

```
int FS_FAT_GetConfig(FS_FAT_CONFIG * pConfig);
```

Parameters

Parameter	Description
<code>pConfig</code>	<code>out</code> Configuration information.

Return value

- = 0 OK, information returned.
- ≠ 0 Error code indicating the failure reason.

4.13.8 FS_FAT_GetLFNConverter()

Description

Returns the type of configured file name converter.

Prototype

```
FS_UNICODE_CONV *FS_FAT_GetLFNConverter(void);
```

Return value

Configured file name converter.

Additional information

This function is available only if `FS_SUPPORT_FILE_NAME_ENCODING` is set to 1 which is the default. Refer to `pUnicodeConv` parameter of `FS_FAT_SetLFNConverter()` for a list of possible return values.

4.13.9 FS_FAT_GrowRootDir()

Description

Increases the size of the root directory.

Prototype

```
U32 FS_FAT_GrowRootDir(const char * sVolumeName,
                      U32      NumAddEntries);
```

Parameters

Parameter	Description
<code>sVolumeName</code>	Name of the volume for which to increase the root directory.
<code>NumAddEntries</code>	Number of directory entries to be added.

Return value

> 0 Number of entries added.
 = 0 Clusters after root directory are not free. The number of entries in the root directory has not been changed.
 = 0xFFFFFFFF An error occurred.

Additional information

The formatting function allocates per default one cluster for the root directory of a FAT32 formatted volume. The file system increases automatically the size of the root directory as more files are added to it. This operation has a certain overhead that depends on the size of the allocation table and on the available free space. This overhead can be eliminated by calling `FS_FAT_GrowRootDir()` to increase the size of the root directory to the number of files and directories the application is expected to store in it.

This function increases the size of the root directory on a FAT32 formatted volume by the number of entries specified in `NumAddEntries`. The file system allocates one directory entry for each file or directory if the support for long file names is not enabled. With the support for long file names enabled the number of directory entries allocated to a file or directory depends on the number of characters in the name of the created file or directory.

This function shall be called after formatting the volume. The function fails with an error if:

- is not called after format operation.
- the specified volume is formatted as FAT12 or FAT16.
- the required number of clusters cannot be allocated immediately after the cluster already allocated to the root directory.

`FS_FAT_GrowRootDir()` is available only if the compile-time option `FS_SUPPORT_FAT` set to 1.

Example

```
#include "FS.h"

void SampleFATGrowRootDir(void) {
    FS_Format("", NULL);
    #if FS_SUPPORT_FAT
        FS_FAT_GrowRootDir("", 64);
    #endif
}
```

4.13.10 FS_FAT_SetLFNConverter()

Description

Configures how long file names are to be encoded and decoded.

Prototype

```
void FS_FAT_SetLFNConverter(const FS_UNICODE_CONV * pUnicodeConv);
```

Parameters

Parameter	Description
<code>pUnicodeConv</code>	File name converter.

Additional information

This function is available only if `FS_SUPPORT_FILE_NAME_ENCODING` is set to 1 which is the default.

Permitted values for `pUnicodeConv` are:

Identifier	Description
<code>FS_UNICODE_CONV_CP437</code>	Unicode <-> CP437 (DOS Latin US) converter
<code>FS_UNICODE_CONV_CP932</code>	Unicode <-> CP932 (Shift JIS) converter
<code>FS_UNICODE_CONV_CP936</code>	Unicode <-> CP936 (GBK) converter
<code>FS_UNICODE_CONV_CP949</code>	Unicode <-> CP949 (Unified Hangul Code) converter
<code>FS_UNICODE_CONV_CP950</code>	Unicode <-> CP950 (Big5) converter
<code>FS_UNICODE_CONV_UTF8</code>	Unicode <-> UTF-8 converter

4.13.11 FS_FAT_SupportLFN()

Description

Enables the support for long file names.

Prototype

```
void FS_FAT_SupportLFN(void);
```

Additional information

The file system accepts per default only file and directory names in 8.3 format, that is maximum 8 characters in the base name of a file, an optional period character, and an optional extension of maximum 3 characters. The application can call `FS_FAT_SupportLFN()` to enable the file system to work with names for files and directories longer than in the 8.3 format.

This function applies only to volumes formatted as FAT. EFS-formatted volumes have native support for long file names.

Example

```
#include "FS.h"

void SampleFATSupportLFN(void) {
    FS_FILE * pFile;

    FS_Init();
    #if FS_SUPPORT_FAT
        FS_FAT_SupportLFN();
    #endif
    pFile = FS_FOpen("This is an unusually long file name", "w");
    if (pFile) {
        FS_FClose(pFile);
    }
}
```

4.13.12 FS_FAT_CONFIG

Description

Information about the FAT configuration.

Type definition

```
typedef struct {
    U8  IsLFNSupported;
    U8  IsFSInfoSectorUsed;
    U8  IsATCopyMaintained;
    U8  IsROFileMovePermitted;
    U8  IsDirtyFlagUpdated;
    U8  IsFAT32Supported;
    U8  IsDeleteOptimized;
    U8  LinearAccessOptimizationLevel;
    U8  IsFreeClusterCacheSupported;
    U8  IsLowerCaseSFNSupported;
} FS_FAT_CONFIG;
```

Structure members

Member	Description
<code>IsLFNSupported</code>	Indicates if the support for long file names is enabled.
<code>IsFSInfoSectorUsed</code>	Indicates if the information about the free clusters is read from the FSInfo sector.
<code>IsATCopyMaintained</code>	Indicates if the copy of the allocation table is update.
<code>IsROFileMovePermitted</code>	Indicates if the file system is allowed to move file that have the read-only attribute set.
<code>IsDirtyFlagUpdated</code>	Indicates if the updates the dirty flag in the BPB sector.
<code>IsFAT32Supported</code>	Indicates if the support for FAT32 formatted volumes is enabled.
<code>IsDeleteOptimized</code>	Indicates if the optimization for the deletion of large files is enabled.
<code>LinearAccessOptimizationLevel</code>	Optimization level for the access to linearly allocated files.
<code>IsFreeClusterCacheSupported</code>	Indicates if the support for the cache of free clusters is enabled.
<code>IsLowerCaseSFNSupported</code>	Indicates if the optimization for storing of short file names in lower case is enabled.

4.14 EFS related functions

The functions described in this section can be used only on volumes formatted as EFS.

4.14.1 FS_EFS_ConfigCaseSensitivity()

Description

Configures how the file names are compared.

Prototype

```
void FS_EFS_ConfigCaseSensitivity(int OnOff);
```

Parameters

Parameter	Description
OnOff	Specifies if the case of a character is important or not. <ul style="list-style-type: none"> • 1 Character case is important. • 0 Character case is ignored.

Additional information

This function is optional and is active only when the file system is compiled with `FS_EFS_CASE_SENSITIVE` set to 1. By default the EFS file system layer ignores the case of a character in file names when it compares two file names. That is, "testfile.txt", "TestFile.txt" and "TESTFILE.TXT" represent the same file name. The case of a file name is preserved when the file is created via `FS_FOpen()` or `FS_FOpenEx()` or in case of a directory when `FS_Mkdir()` and `FS_CreateDir()` is called to create one.

If the case sensitivity is enabled by calling `FS_EFS_ConfigCaseSensitivity()` with the `OnOff` parameter set to 1 than "testfile.txt", "TestFile.txt" and "TESTFILE.TXT" are three different file names.

4.14.2 FS_EFS_ConfigStatusSectorSupport()

Description

Enables or disables the usage of information from the status sector.

Prototype

```
void FS_EFS_ConfigStatusSectorSupport(int OnOff);
```

Parameters

Parameter	Description
<code>OnOff</code>	Specifies if the status sector information has to be used or not. <ul style="list-style-type: none">• 1 Status sector information is used.• 0 Status sector information is not used.

Additional information

This function is optional and is active only when the file system is compiled with `FS_EFS_SUPPORT_STATUS_SECTOR` set to 1. The status sector stores information about the free space available on the storage which helps the file system improve the performance of the operations that return the available free space such as `FS_GetVolumeInfo()`.

4.14.3 FS_EFS_GetConfig()

Description

Returns information about how the EFS component is configured to operate.

Prototype

```
int FS_EFS_GetConfig(FS_EFS_CONFIG * pConfig);
```

Parameters

Parameter	Description
<code>pConfig</code>	<code>out</code> Configuration information.

Return value

- = 0 OK, information returned.
- ≠ 0 Error code indicating the failure reason.

4.14.4 FS_EFS_SetFileNameConverter()

Description

Configures how file names are to be encoded.

Prototype

```
void FS_EFS_SetFileNameConverter(const FS_UNICODE_CONV * pUnicodeConv);
```

Parameters

Parameter	Description
<code>pUnicodeConv</code>	File name converter.

Additional information

This function is available only if `FS_SUPPORT_FILE_NAME_ENCODING` is set to 1. By default, `FS_SUPPORT_FILE_NAME_ENCODING` is set to 0 in order to reduce the RAM and ROM usage.

Permitted values for `pUnicodeConv` are:

Identifier	Description
<code>FS_UNICODE_CONV_CP437</code>	Unicode <-> CP437 (DOS Latin US) converter
<code>FS_UNICODE_CONV_CP932</code>	Unicode <-> CP932 (Shift JIS) converter
<code>FS_UNICODE_CONV_CP936</code>	Unicode <-> CP936 (GBK) converter
<code>FS_UNICODE_CONV_CP949</code>	Unicode <-> CP949 (Unified Hangul Code) converter
<code>FS_UNICODE_CONV_CP950</code>	Unicode <-> CP950 (Big5) converter
<code>FS_UNICODE_CONV_UTF8</code>	Unicode <-> UTF-8 converter

4.14.5 FS_EFS_CONFIG

Description

Information about the EFS configuration.

Type definition

```
typedef struct {
    U8  IsStatusSectorSupported;
    U8  IsCaseSensitiveName;
    U8  IsDirEntryBufferSupported;
    U8  NumDirEntryBuffers;
    U8  IsDeleteOptimized;
    U8  LinearAccessOptimizationLevel;
    U8  IsFreeClusterCacheSupported;
    U8  MaxDirEntrySize;
} FS_EFS_CONFIG;
```

Structure members

Member	Description
IsStatusSectorSupported	Indicates if the information of the status sector is updated.
IsCaseSensitiveName	Indicates if the comparison of file names is case sensitive.
IsDirEntryBufferSupported	Indicates if the support for directory entry buffers is enabled.
NumDirEntryBuffers	Number of configured directory entry buffers.
IsDeleteOptimized	Indicates if the optimization for the deletion of large files is enabled.
LinearAccessOptimizationLevel	Optimization level for the access to linearly allocated files.
IsFreeClusterCacheSupported	Indicates if the support for the cache of free clusters is enabled.
MaxDirEntrySize	Maximum number of bytes in a directory entry.

4.15 Error-handling functions

An application can use the following functions to check and clear the error status of a file handle.

4.15.1 FS_ClearErr()

Description

Clears error status of a file handle.

Prototype

```
void FS_ClearErr(FS_FILE * pFile);
```

Parameters

Parameter	Description
<code>pFile</code>	Handle to opened file.

Additional information

The function sets the error status of a file handle to `FS_ERRCODE_OK`. `FS_ClearErr()` is the only function that clears the error status of a file handle. The other API functions modify the error status of a file handle only if it is cleared. The application has to call this function after it detects that an error occurred during a file system operation on an opened file handle and before it starts a new file system operation if it wants to get the correct error status in case of a failure.

Example

```
#include <stdio.h>
#include "FS.h"

void SampleClearErr(void) {
    FS_FILE * pFile;
    U32      aBuffer[32 / 4];
    int      ErrCode;
    char     ac[100];
    U32      NumBytesRead;

    pFile = FS_FOpen("Test.txt", "r");
    if (pFile) {
        NumBytesRead = FS_Read(pFile, aBuffer, sizeof(aBuffer));
        ErrCode = FS_FError(pFile);
        if (ErrCode == FS_ERRCODE_OK) {
            SEGGER_sprintf(ac, sizeof(ac), "First read operation failed with: %d (%s)\n",
                ErrCode, FS_ErrorNo2Text(ErrCode));
            FS_X_Log(ac);
            FS_ClearErr(pFile);
        } else {
            SEGGER_sprintf(ac, sizeof(ac), "The first operation read %lu bytes from file.\n",
                NumBytesRead);
            FS_X_Log(ac);
        }
    }
    NumBytesRead = FS_Read(pFile, aBuffer, sizeof(aBuffer));
    ErrCode = FS_FError(pFile);
    if (ErrCode != FS_ERRCODE_OK) {
        SEGGER_sprintf(ac, sizeof(ac), "Second read operation failed with: %d (%s)\n",
            ErrCode, FS_ErrorNo2Text(ErrCode));
        FS_X_Log(ac);
        FS_ClearErr(pFile);
    } else {
        SEGGER_sprintf(ac, sizeof(ac), "The second operation read %lu bytes from file.\n",
            NumBytesRead);
        FS_X_Log(ac);
    }
    FS_FClose(pFile);
}
}
```

4.15.2 FS_ErrorNo2Text()

Description

Returns a human-readable text description of an API error code.

Prototype

```
char *FS_ErrorNo2Text(int ErrCode);
```

Parameters

Parameter	Description
ErrCode	Error code for which the text description has to be returned.

Return value

The text description as 0-terminated ASCII string.

Additional information

For a list of supported error codes refer to *Error codes* on page 335. If the error code is not known FS_ErrorNo2Text() returns the "Unknown error" string. The error status of an opened file handle can be queried via FS_FError(). Most of the API functions of the file system also return one of the defined codes in case of an error. This error code can be passed to FS_ErrorNo2Text() to get a human-readable text description.

Example

```
#include <stdio.h>
#include "FS.h"

void SampleErrorNo2Text(void) {
    FS_FILE * pFile;
    int      r;
    char     ac[100];

    r = FS_FOpenEx("Test.txt", "r", &pFile);
    if (r) {
        SEGGER_sprintf(ac, sizeof(ac),
            "The file open operation failed with: %d (%s)\n", r, FS_ErrorNo2Text(r));
        FS_X_Log(ac);
    } else {
        //
        // Access the file contents...
        //
        FS_FClose(pFile);
    }
}
```

4.15.3 FS_FEOF()

Description

Returns if end of file has been reached.

Prototype

```
int FS_FEOF(FS_FILE * pFile);
```

Parameters

Parameter	Description
<code>pFile</code>	Handle to opened file.

Return value

= 1 An attempt was made to read beyond the end of the file.
 = 0 The end of file has not been reached.
 < 0 An error occurred.

Additional information

The end-of-file flag of the file handle is set by the file system when the application tries to read more bytes than available in the file. This is not an error condition but just an indication that the file pointer is positioned beyond the last byte in the file and that by trying to read from this position no bytes are returned.

Example

```
#include "FS.h"

void SampleFEof(void) {
    FS_FILE * pFile;
    U32      aBuffer[32 / 4];
    int      r;
    int      ErrCode;

    pFile = FS_FOpen("Test.txt", "r");
    if (pFile) {
        while (1) {
            FS_Read(pFile, aBuffer, sizeof(aBuffer));
            if (FS_FEOF(pFile)) {
                break;           // End of file reached.
            }
            ErrCode = FS_FError(pFile);
            if (ErrCode) {
                break;           // An error occurred while reading from file.
            }
        }
        FS_FClose(pFile);
    }
}
```

4.15.4 FS_FError()

Description

Returns error status of a file handle.

Prototype

```
I16 FS_FError(FS_FILE * pFile);
```

Parameters

Parameter	Description
<code>pFile</code>	Handle to opened file.

Return value

= FS_ERRCODE_OK No error present.
 ≠ FS_ERRCODE_OK An error has occurred.

Additional information

The application can use this function to check what kind of error caused an API function that does not return an error code such as `FS_Read()`, `FS_FRead()`, `FS_Write()` or `FS_FWrite()` to fail. The error status remains set until the application calls `FS_ClearErr()`.

`FS_ErrorNo2Text()` can be used to return a human-readable description of the error as a 0-terminated string.

Example

```
#include <stdio.h>
#include "FS.h"

void SampleFError(void) {
    FS_FILE * pFile;
    U32      aBuffer[32 / 4];
    int      ErrCode;
    char     ac[100];
    U32      NumBytesRead;

    pFile = FS_FOpen("Test.txt", "r");
    if (pFile) {
        NumBytesRead = FS_Read(pFile, aBuffer, sizeof(aBuffer));
        ErrCode = FS_FError(pFile);
        if (ErrCode != FS_ERRCODE_OK) {
            SEGGER_sprintf(ac, sizeof(ac), "The read operation failed with: %d (%s)\n",
                ErrCode, FS_ErrorNo2Text(ErrCode));
            FS_X_Log(ac);
            FS_ClearErr(pFile);
        } else {
            SEGGER_sprintf(ac, sizeof(ac), "The operation read %lu bytes from file.\n",
                NumBytesRead);
            FS_X_Log(ac);
        }
        FS_FClose(pFile);
    }
}
```

4.15.5 Error codes

Description

Values returned by the API functions to indicate the reason of an error.

Definition

```
#define FS_ERRCODE_OK 0
#define FS_ERRCODE_EOF (-1)
#define FS_ERRCODE_PATH_TOO_LONG (-2)
#define FS_ERRCODE_INVALID_PARA (-3)
#define FS_ERRCODE_WRITE_ONLY_FILE (-5)
#define FS_ERRCODE_READ_ONLY_FILE (-6)
#define FS_ERRCODE_READ_FAILURE (-7)
#define FS_ERRCODE_WRITE_FAILURE (-8)
#define FS_ERRCODE_FILE_IS_OPEN (-9)
#define FS_ERRCODE_PATH_NOT_FOUND (-10)
#define FS_ERRCODE_FILE_DIR_EXISTS (-11)
#define FS_ERRCODE_NOT_A_FILE (-12)
#define FS_ERRCODE_TOO_MANY_FILES_OPEN (-13)
#define FS_ERRCODE_INVALID_FILE_HANDLE (-14)
#define FS_ERRCODE_VOLUME_NOT_FOUND (-15)
#define FS_ERRCODE_READ_ONLY_VOLUME (-16)
#define FS_ERRCODE_VOLUME_NOT_MOUNTED (-17)
#define FS_ERRCODE_NOT_A_DIR (-18)
#define FS_ERRCODE_FILE_DIR_NOT_FOUND (-19)
#define FS_ERRCODE_NOT_SUPPORTED (-20)
#define FS_ERRCODE_CLUSTER_NOT_FREE (-21)
#define FS_ERRCODE_INVALID_CLUSTER_CHAIN (-22)
#define FS_ERRCODE_STORAGE_NOT_PRESENT (-23)
#define FS_ERRCODE_BUFFER_NOT_AVAILABLE (-24)
#define FS_ERRCODE_STORAGE_TOO_SMALL (-25)
#define FS_ERRCODE_STORAGE_NOT_READY (-26)
#define FS_ERRCODE_BUFFER_TOO_SMALL (-27)
#define FS_ERRCODE_INVALID_FS_FORMAT (-28)
#define FS_ERRCODE_INVALID_FS_TYPE (-29)
#define FS_ERRCODE_FILENAME_TOO_LONG (-30)
#define FS_ERRCODE_VERIFY_FAILURE (-31)
#define FS_ERRCODE_VOLUME_FULL (-32)
#define FS_ERRCODE_DIR_NOT_EMPTY (-33)
#define FS_ERRCODE_IOCTL_FAILURE (-34)
#define FS_ERRCODE_INVALID_MBR (-35)
#define FS_ERRCODE_OUT_OF_MEMORY (-36)
#define FS_ERRCODE_UNKNOWN_DEVICE (-37)
#define FS_ERRCODE_ASSERT_FAILURE (-38)
#define FS_ERRCODE_TOO_MANY_TRANSACTIONS_OPEN (-39)
#define FS_ERRCODE_NO_OPEN_TRANSACTION (-40)
#define FS_ERRCODE_INIT_FAILURE (-41)
#define FS_ERRCODE_FILE_TOO_LARGE (-42)
#define FS_ERRCODE_HW_LAYER_NOT_SET (-43)
#define FS_ERRCODE_INVALID_USAGE (-44)
#define FS_ERRCODE_TOO_MANY_INSTANCES (-45)
#define FS_ERRCODE_TRANSACTION_ABORTED (-46)
#define FS_ERRCODE_INVALID_CHAR (-47)
#define FS_ERRCODE_INVALID_GPT (-48)
#define FS_ERRCODE_INVALID_CONTENT (-49)
#define FS_ERRCODE_COMPRESS_FAILURE (-50)
```

Symbols

Definition	Description
FS_ERRCODE_OK	No error
FS_ERRCODE_EOF	End of file reached

Definition	Description
FS_ER- RCODE_PATH_TOO_LONG	Path to file or directory is too long
FS_ERRCODE_IN- VALID_PARA	Invalid parameter passed
FS_ERRCODE_WRITE_ON- LY_FILE	File can only be written
FS_ERRCODE_READ_ON- LY_FILE	File can not be written
FS_ER- RCODE_READ_FAILURE	Error while reading from storage medium
FS_ER- RCODE_WRITE_FAILURE	Error while writing to storage medium
FS_ER- RCODE_FILE_IS_OPEN	Trying to delete a file which is open
FS_ER- RCODE_PATH_NOT_FOUND	Path to file or directory not found
FS_ER- RCODE_FILE_DIR_EXISTS	File or directory already exists
FS_ERRCODE_NOT_A_FILE	Trying to open a directory instead of a file
FS_ER- RCODE_TOO_MANY_FILES_OPEN	Exceeded number of files opened at once
FS_ERRCODE_IN- VALID_FILE_HANDLE	The file handle has been invalidated
FS_ERRCODE_VOL- UME_NOT_FOUND	The volume name specified in a path is does not exist
FS_ERRCODE_READ_ON- LY_VOLUME	Trying to write to a volume mounted in read-only mode
FS_ERRCODE_VOL- UME_NOT_MOUNTED	Trying access a volume which is not mounted
FS_ERRCODE_NOT_A_DIR	Trying to open a file instead of a directory
FS_ER- RCODE_FILE_DIR_NOT_FOUND	File or directory not found
FS_ERRCODE_NOT_SUP- PORTED	Functionality not supported
FS_ER- RCODE_CLUSTER_NOT_FREE	Trying to allocate a cluster which is not free
FS_ERRCODE_IN- VALID_CLUSTER_CHAIN	Detected a shorter than expected cluster chain
FS_ERRCODE_STOR- AGE_NOT_PRESENT	Trying to access a removable storage which is not inserted
FS_ER- RCODE_BUFFER_NOT_AVAILABLE	No more sector buffers available
FS_ERRCODE_STOR- AGE_TOO_SMALL	Not enough sectors on the storage medium
FS_ERRCODE_STOR- AGE_NOT_READY	Storage device can not be accessed
FS_ER- RCODE_BUFFER_TOO_S- MALL	Sector buffer smaller than sector size of storage medium

Definition	Description
<code>FS_ERRCODE_INVALID_FS_FORMAT</code>	Storage medium is not formatted or the format is not valid
<code>FS_ERRCODE_INVALID_FS_TYPE</code>	Type of file system is invalid or not configured
<code>FS_ERRCODE_FILENAME_TOO_LONG</code>	The name of the file is too long
<code>FS_ERRCODE_VERIFY_FAILURE</code>	Data verification failure
<code>FS_ERRCODE_VOLUME_FULL</code>	No more space on storage medium
<code>FS_ERRCODE_DIR_NOT_EMPTY</code>	Trying to delete a directory which is not empty
<code>FS_ERRCODE_IOCTL_FAILURE</code>	Error while executing a driver control command
<code>FS_ERRCODE_INVALID_MBR</code>	Invalid information in the Master Boot Record
<code>FS_ERRCODE_OUT_OF_MEMORY</code>	Could not allocate memory
<code>FS_ERRCODE_UNKNOWN_DEVICE</code>	Storage device is not configured
<code>FS_ERRCODE_ASSERT_FAILURE</code>	<code>FS_DEBUG_ASSERT()</code> macro failed
<code>FS_ERRCODE_TOO_MANY_TRANSACTIONS_OPEN</code>	Maximum number of opened journal transactions exceeded
<code>FS_ERRCODE_NO_OPEN_TRANSACTION</code>	Trying to close a journal transaction which is not opened
<code>FS_ERRCODE_INIT_FAILURE</code>	Error while initializing the storage medium
<code>FS_ERRCODE_FILE_TOO_LARGE</code>	Trying to write to a file which is larger than 4 Gbytes
<code>FS_ERRCODE_HW_LAYER_NOT_SET</code>	The HW layer is not configured
<code>FS_ERRCODE_INVALID_USAGE</code>	Trying to call a function in an invalid state
<code>FS_ERRCODE_TOO_MANY_INSTANCES</code>	Trying to create one instance more than maximum configured
<code>FS_ERRCODE_TRANSACTION_ABORTED</code>	A journal transaction has been stopped by the application
<code>FS_ERRCODE_INVALID_CHAR</code>	Invalid character in the name of a file
<code>FS_ERRCODE_INVALID_GUID_PT</code>	Invalid information in the GUID partition
<code>FS_ERRCODE_INVALID_CONTENT</code>	The content of a file is invalid
<code>FS_ERRCODE_COMPRESS_FAILURE</code>	Error while compressing or decompressing the data.

Additional information

The last error code of an file handle can be checked using `FS_FError()`.

4.16 Configuration checking functions

The functions described in this section are useful to check at runtime how the file system has been configured at compile time.

4.16.1 FS_CONF_GetDebugLevel()

Description

Returns the level of debug information configured for the file system.

Prototype

```
int FS_CONF_GetDebugLevel(void);
```

Return value

Value of `FS_DEBUG_LEVEL` configuration define.

4.16.2 FS_CONF_GetDirectoryDelimiter()

Description

Returns the character that is configured as delimiter between the directory names in a file path.

Prototype

```
char FS_CONF_GetDirectoryDelimiter(void);
```

Return value

Value of `FS_DIRECTORY_DELIMITER` configuration define.

Example

```
#include <stdio.h>
#include "FS.h"

void SampleCONFGetDirectoryDelimiter(void) {
    char ac[100];
    char Delim;

    Delim = FS_CONF_GetDirectoryDelimiter();
    SEGGER_sprintf(ac, sizeof(ac),
        "The '%c' character is used to delimit directory names in a path\n", Delim);
    FS_X_Log(ac);
}
```

4.16.3 FS_CONF_GetMaxPath()

Description

Returns the configured maximum number of characters in a path to a file or directory.

Prototype

```
int FS_CONF_GetMaxPath(void);
```

Return value

Value of `FS_MAX_PATH` configuration define.

Example

```
#include <stdio.h>
#include "FS.h"

void SampleCONFGetMaxPath(void) {
    char ac[100];
    int NumChars;

    NumChars = FS_CONF_GetMaxPath();
    SEGGER_sprintf(ac, sizeof(ac),
        "The maximum number of characters in the path is: %d\n", NumChars);
    FS_X_Log(ac);
}
```

4.16.4 FS_CONF_GetNumVolumes()

Description

Returns the maximum number of volumes configured for the file system.

Prototype

```
int FS_CONF_GetNumVolumes(void);
```

Return value

Returns the value of `FS_NUM_VOLUMES` configuration define.

Example

```
#include <stdio.h>
#include "FS.h"

void SampleCONFGgetNumVolumes(void) {
    char ac[100];
    int NumVolumes;

    NumVolumes = FS_CONF_GetNumVolumes();
    SEGGER_sprintf(ac, sizeof(ac),
        "The maximum number of supported by Journal: %d\n", NumVolumes);
    FS_X_Log(ac);
}
```

4.16.5 FS_CONF_GetOSLocking()

Description

Returns the type of task locking configured for the file system.

Prototype

```
int FS_CONF_GetOSLocking(void);
```

Return value

Value of FS_OS_LOCKING configuration define.

Example

```
#include "FS.h"

void SampleCONFGetOSLocking(void) {
    int LockingType;

    LockingType = FS_CONF_GetOSLocking();
    switch (LockingType) {
        case FS_OS_LOCKING_NONE:
            FS_X_Log("The file system is not locked against concurrent access.\n");
            break;
        case FS_OS_LOCKING_API:
            FS_X_Log("The file system is locked at API function level.\n");
            break;
        case FS_OS_LOCKING_DRIVER:
            FS_X_Log("The file system is locked at device driver level.\n");
            break;
        default:
            FS_X_Log("The type of locking is unknown.\n");
            break;
    }
}
```

4.16.6 FS_CONF_IsCacheSupported()

Description

Checks if the file system is configured to support the sector cache.

Prototype

```
int FS_CONF_IsCacheSupported(void);
```

Return value

Value of `FS_SUPPORT_CACHE` configuration define.

Additional information

This function does not check if the sector cache is actually active. It only indicates if the file system has been compiled with support for sector cache. The sector cache has to be activated via `FS_AssignCache()`.

Example

```
#include "FS.h"

void SampleCONFIIsCacheSupported(void) {
    int IsSupported;

    IsSupported = FS_CONF_IsCacheSupported();
    if (IsSupported) {
        FS_X_Log("The sector cache is supported.\n");
    } else {
        FS_X_Log("The sector cache is not supported.\n");
    }
}
```

4.16.7 FS_CONF_IsDeInitSupported()

Description

Checks if the file system is configured to support deinitialization.

Prototype

```
int FS_CONF_IsDeInitSupported(void);
```

Return value

Value of FS_SUPPORT_DEINIT configuration define.

Example

```
#include "FS.h"

void SampleCONFIIsDeInitSupported(void) {
    int IsSupported;

    IsSupported = FS_CONF_IsDeInitSupported();
    if (IsSupported) {
        FS_X_Log("File system deinitialization is supported.\n");
    } else {
        FS_X_Log("File system deinitialization is not supported.\n");
    }
}
```

4.16.8 FS_CONF_IsEFSSupported()

Description

Checks if the file system is configured to support the EFS file system.

Prototype

```
int FS_CONF_IsEFSSupported(void);
```

Return value

Value of FS_SUPPORT_EFS configuration define.

Example

```
#include "FS.h"

void SampleCONFIseFSSupported(void) {
    int IsSupported;

    IsSupported = FS_CONF_IsEFSSupported();
    if (IsSupported) {
        FS_X_Log("The file system supports EFS.\n");
    } else {
        FS_X_Log("The file system does not support EFS.\n");
    }
}
```

4.16.9 FS_CONF_IsEncryptionSupported()

Description

Checks if the file system is configured to support encryption.

Prototype

```
int FS_CONF_IsEncryptionSupported(void);
```

Return value

Value of FS_SUPPORT_ENCRYPTION configuration define.

Example

```
#include "FS.h"

void SampleCONFIEncryptionSupported(void) {
    int IsSupported;

    IsSupported = FS_CONF_IsEncryptionSupported();
    if (IsSupported) {
        FS_X_Log("The file system supports encryption.\n");
    } else {
        FS_X_Log("The file system does not support encryption.\n");
    }
}
```

4.16.10 FS_CONF_IsFATSupported()

Description

Checks if the file system is configured to support the FAT file system.

Prototype

```
int FS_CONF_IsFATSupported(void);
```

Return value

Value of `FS_SUPPORT_FAT` configuration define.

Example

```
#include "FS.h"

void SampleCONFIIsFATSupported(void) {
    int IsSupported;

    IsSupported = FS_CONF_IsFATSupported();
    if (IsSupported) {
        FS_X_Log("The file system supports FAT.\n");
    } else {
        FS_X_Log("The file system does not support FAT.\n");
    }
}
```

4.16.11 FS_CONF_IsFreeSectorSupported()

Description

Checks if the file system is configured to support the "free sector" command.

Prototype

```
int FS_CONF_IsFreeSectorSupported(void);
```

Return value

Value of FS_SUPPORT_FREE_SECTOR configuration define.

Example

```
#include "FS.h"

void SampleCONFIsFreeSectorSupported(void) {
    int IsSupported;

    IsSupported = FS_CONF_IsFreeSectorSupported();
    if (IsSupported) {
        FS_X_Log("The file system supports \"free sector\" operation.\n");
    } else {
        FS_X_Log("The file system does not support \"free sector\" operation.\n");
    }
}
```

4.16.12 FS_CONF_IsJournalSupported()

Description

Checks if the file system is configured to support journaling.

Prototype

```
int FS_CONF_IsJournalSupported(void);
```

Return value

Value of FS_SUPPORT_JOURNAL configuration define.

Example

```
#include "FS.h"

void SampleCONFIsJournalSupported(void) {
    int IsSupported;

    IsSupported = FS_CONF_IsJournalSupported();
    if (IsSupported) {
        FS_X_Log("The file system supports journaling.\n");
    } else {
        FS_X_Log("The file system does not support journaling.\n");
    }
}
```

4.16.13 FS_CONF_IsTrialVersion()

Description

Checks if the file system has been configured as a trial (limited) version.

Prototype

```
int FS_CONF_IsTrialVersion(void);
```

Return value

= 0 Full version.
≠ 0 Trial version.

Example

```
#include "FS.h"

void SampleCONFIsTrialVersion(void) {
    int IsTrial;

    IsTrial = FS_CONF_IsTrialVersion();
    if (IsTrial) {
        FS_X_Log("This is a trial version of emFile.\n");
    } else {
        FS_X_Log("This is a full-featured version of emFile.\n");
    }
}
```

4.16.14 FS_GetVersion()

Description

Returns the version number of the file system.

Prototype

```
U32 FS_GetVersion(void);
```

Return value

Version number.

Additional information

The version is formatted as follows: Mmmrr

where:

- `M` the major version number
- `mm` the minor version number
- `rr` the revision number

For example 40201 represents the version 4.02a (major version: 4, minor version: 2, revision: a)

Example

```
#include <stdio.h>
#include "FS.h"

void SampleGetVersion(void) {
    int Version;
    int MajorVersion;
    int MinorVersion;
    char PatchVersion;
    char ac[100];

    Version = FS_GetVersion();
    MajorVersion = Version / 10000;
    MinorVersion = Version / 100 % 100;
    PatchVersion = Version % 100;
    SEGGER_sprintf(ac, sizeof(ac), "This is the version %d.%d.%d of emFile.\n",
        MajorVersion, MinorVersion, PatchVersion);
    FS_X_Log(ac);
}
```

4.17 Obsolete functions

This section describes API functions that should no longer be used in new applications. These functions will be removed in a future version of emFile.

4.17.1 FS_AddOnExitHandler()

Description

Registers a deinitialization callback.

Prototype

```
void FS_AddOnExitHandler(FS_ON_EXIT_CB * pCB,  
                        void (*pfOnExit)());
```

Parameters

Parameter	Description
pCB	in Structure holding the callback information.
pfOnExit	Pointer to the callback function to be invoked.

Additional information

The [pCB](#) memory location is used internally by the file system and it should remain valid from the time the handler is registered until the `FS_DeInit()` function is called. The `FS_DeInit()` function invokes all the registered callback functions in reversed order that is the last registered function is called first. In order to use this function the binary compile time switch `FS_SUPPORT_DEINIT` has to be set to 1.

4.17.2 FS_CloseDir()

Description

Closes a directory.

Prototype

```
int FS_CloseDir(FS_DIR * pDir);
```

Parameters

Parameter	Description
<code>pDir</code>	Handle to an opened directory.

Return value

= 0 Directory has been closed.
≠ 0 An error occurred.

4.17.3 FS_ConfigOnWriteDirUpdate()

Description

Configures if the directory entry has be updated after writing to file.

Prototype

```
void FS_ConfigOnWriteDirUpdate(char OnOff);
```

Parameters

Parameter	Description
OnOff	Specifies if the feature has to be enabled or disabled. <ul style="list-style-type: none">• 1 Enable update directory after write.• 0 Do not update directory. FS_FClose() updates the directory entry.

4.17.4 FS_DirEnt2Attr()

Description

Loads attributes of a directory entry.

Prototype

```
void FS_DirEnt2Attr(FS_DIRENT * pDirEnt,  
                   U8          * pAttr);
```

Parameters

Parameter	Description
<code>pDirEnt</code>	in Data of directory entry.
<code>pAttr</code>	out Pointer to a memory location that receives the attributes.

4.17.5 FS_DirEnt2Name()

Description

Loads the name of a directory entry.

Prototype

```
void FS_DirEnt2Name(FS_DIRENT * pDirEnt,  
                   char * pBuffer);
```

Parameters

Parameter	Description
<code>pDirEnt</code>	in Data of directory entry.
<code>pBuffer</code>	out Pointer to a memory location that receives the name.

4.17.6 FS_DirEnt2Size()

Description

Loads the size of a directory entry.

Prototype

```
U32 FS_DirEnt2Size(FS_DIRENT * pDirEnt);
```

Parameters

Parameter	Description
<code>pDirEnt</code>	<code>in</code> Data of directory entry.

Return value

Size of the file or directory.

4.17.7 FS_DirEnt2Time()

Description

Loads the time stamp of a directory entry.

Prototype

```
U32 FS_DirEnt2Time(FS_DIRENT * pDirEnt);
```

Parameters

Parameter	Description
<code>pDirEnt</code>	<code>in</code> Data of directory entry.

Return value

Time stamp of the file or directory.

4.17.8 FS_GetNumFiles()

Description

API function. Returns the number of files in a directory.

Prototype

```
U32 FS_GetNumFiles(FS_DIR * pDir);
```

Parameters

Parameter	Description
<code>pDir</code>	Pointer to an opened directory handle.

Return value

0xFFFFFFFF Indicates failure. 0 - 0xFFFFFFFF File size of the given file.

4.17.9 FS_OpenDir()

Description

API function. Open an existing directory for reading.

Prototype

```
FS_DIR *FS_OpenDir(const char * sDirName);
```

Parameters

Parameter	Description
<code>sDirName</code>	Fully qualified directory name.

Return value

- = 0 Unable to open the directory.
- ≠ 0 Address of an `FS_DIR` data structure.

4.17.10 FS_ReadDir()

Description

Reads next directory entry in directory.

Prototype

```
FS_DIRENT *FS_ReadDir(FS_DIR * pDir);
```

Parameters

Parameter	Description
pDir	Handle to an opened directory.

Return value

- ≠ 0 Pointer to a directory entry.
- = 0 No more directory entries or error.

4.17.11 FS_RewindDir()

Description

Sets pointer for reading the next directory entry to the first entry in the directory.

Prototype

```
void FS_RewindDir(FS_DIR * pDir);
```

Parameters

Parameter	Description
<code>pDir</code>	Handle to an opened directory.

Chapter 5

Caching and buffering

This chapter gives an introduction into cache handling of emFile. Furthermore, it contains the function description and an example.

5.1 Sector cache

The sector cache is a memory area where frequently used sector data can be stored for fast access. In many cases, this can enhance the average access time thus increasing the performance. With applications which do not use a cache, data will always be read from the storage medium even if it has been used before. The sector cache stores accessed and processed sector data. If the sector data has to be processed again, it will be copied out of the cache instead of reading it from the storage device. This condition is called "hit". When the sector data is not present in the sector cache and it has to be read from the storage device. This condition is called "miss". The sector cache works efficiently when the number of hit conditions is greater than the number of miss conditions. The number of hit and miss conditions can be queried using the `FS_STORAGE_GetCounters()` function.

5.1.1 Write cache and journaling

The write back caching has to be disabled if the journaling is employed to make the file system fail safe. The journaling will not work properly if the write back cache (and generally any form of write cache) is enabled. More detailed information can be found in the section *Journaling and write caching* on page 1302.

5.1.2 Types of caches

emFile supports the usage of different cache modules as listed in the following table:

Cache module	Description
<code>FS_CACHE_ALL</code>	A pure read cache.
<code>FS_CACHE_MAN</code>	A pure read cache that caches only the management sectors.
<code>FS_CACHE_RW</code>	A read / write cache module.
<code>FS_CACHE_RW_QUOTA</code>	A read / write cache module with configurable capacity per sector type.
<code>FS_CACHE_MULTI_WAY</code>	A read / write cache module with configurable associativity level.

5.1.2.1 FS_CACHE_ALL

This module is a pure read cache. All sectors that are read from a volume are cached. The caching is enabled right after calling `FS_AssignCache()`.

5.1.2.2 FS_CACHE_MAN

This module is also a pure read cache. In contrast to the `FS_CACHE_ALL`, this module only caches the management sectors of the file system (for example, the sectors of the allocation table). The caching is enabled right after calling `FS_AssignCache()`. This type of cache is useful if the application is creating and deleting a large number of files.

5.1.2.3 FS_CACHE_RW

This is a configurable cache module. It can be either used as read, write or as read / write cache. Additionally, the type of sectors that has to be cached are also configurable via `FS_CACHE_SetMode()`.

5.1.2.4 FS_CACHE_RW_QUOTA

This is a configurable cache module. It can be either used as read, write or as read / write cache. Additionally, the type of sectors and the maximum number of sectors of a given type that can be cached at the same time are configurable via `FS_CACHE_SetMode()` and `FS_CACHE_SetQuota()` respectively. It is mandatory to call `FS_CACHE_SetMode()` and `FS_CACHE_SetQuota()`, otherwise the functionality of the cache module is disabled.

5.1.2.5 FS_CACHE_MULTI_WAY

This is configurable cache module that can be used as read, write or read / write cache. The type of sectors that should be cached and the number of places in the cache where the data of a sector can be mapped (associativity level) is configurable via `FS_CACHE_SetMode()` and `FS_CACHE_SetQuota()` respectively. Per default, this cache works with an associativity level of two.

5.1.3 Cache API functions

The following functions can be used to enable, configure and control the emFile sector cache modules.

Function	Description
FS_AssignCache()	Enables / disables a sector cache for a specific volume.
FS_CACHE_Clean()	Writes modified sector data to storage device.
FS_CACHE_GetNumSectors()	Queries the size of the sector cache.
FS_CACHE_GetType()	Queries the type of the configured sector cache.
FS_CACHE_Invalidate()	Removes all sector data from cache.
FS_CACHE_SetAssocLevel()	Modifies the associativity level of multi-way cache.
FS_CACHE_SetMode()	Sets the operating mode of sector cache.
FS_CACHE_SetQuota()	Sets the quotas of a specific sector cache.

5.1.3.1 FS_AssignCache()

Description

Enables / disables a sector cache for a specific volume.

Prototype

```
U32 FS_AssignCache(const char      * sVolumeName,
                  void            * pData,
                  I32              NumBytes,
                  FS_CACHE_TYPE   Type);
```

Parameters

Parameter	Description
<code>sVolumeName</code>	Name of the volume on which the sector cache should be enabled / disabled. Cannot be <code>NULL</code> .
<code>pData</code>	Pointer to a memory area that should be used as cache.
<code>NumBytes</code>	Number of bytes in the memory area pointed by <code>pData</code> .
<code>Type</code>	<code>Type</code> of the sector cache to be configured. It can take one of the following values: <ul style="list-style-type: none"> • <code>FS_CACHE_ALL</code> • <code>FS_CACHE_MAN</code> • <code>FS_CACHE_RW</code> • <code>FS_CACHE_RW_QUOTA</code> • <code>FS_CACHE_MULTI_WAY</code>.

Return value

> 0 Number of sectors which fit in cache.
= 0 An error occurred. The memory area cannot be used as sector cache.

Additional information

The first configured volume is used if the empty string is specified as `sVolumeName`.

To disable the cache for a specific device, call `FS_AssignCache()` with `NumBytes` set to 0. In this case the function returns 0.

A range of the memory block assigned to the sector cache is used to store the management data. The following defines can help an application allocate a memory block sufficiently large to store a specified number of logical sectors: `FS_SIZEOF_CACHE_ALL()`, `FS_SIZEOF_CACHE_MAN()`, `FS_SIZEOF_CACHE_RW()`, `FS_SIZEOF_CACHE_RW_QUOTA()`, or `FS_SIZEOF_CACHE_MULTI_WAY()`.

Example

The following example demonstrates how to enable and then disable a sector cache of type `FS_CACHE_ALL`.

```
#include "FS.h"

#define CACHE_SIZE FS_SIZEOF_CACHE_ALL(200, 512) // 200 sectors of 512 bytes.

static U32 _aCache[CACHE_SIZE / 4]; // Allocate RAM for the cache buffer.

void SampleCacheAssign(void) {
    //
    // Assign a read cache to the first configured storage device.
    //
    FS_AssignCache("", _aCache, sizeof(_aCache), FS_CACHE_ALL);

    //
    // Access the file system with sector cache.
```

```
//  
  
//  
// Disable the read cache.  
//  
FS_AssignCache("", 0, 0, 0);  
}
```

5.1.3.2 FS_CACHE_Clean()

Description

Writes modified sector data to storage device.

Prototype

```
int FS_CACHE_Clean(const char * sVolumeName);
```

Parameters

Parameter	Description
<code>sVolumeName</code>	Name of the volume for which the cache should be cleaned. If not specified, the first volume will be used.

Return value

= 0 Success, the cache has been emptied.
≠ 0 An error occurred.

Additional information

This function can be used to make sure that modifications made to cached data are also committed to storage device.

Because only write or read / write caches need to be cleaned, this function can only be called for volumes where `FS_CACHE_RW`, `FS_CACHE_RW_QUOTA`, or `FS_CACHE_MULTI_WAY` module is assigned. The other cache modules ignore the cache clean operation.

The cleaning of the cache is also performed when the volume is unmounted via `FS_Unmount()` or when the cache is disabled or reassigned via `FS_AssignCache()`.

Example

```
#include "FS.h"

void SampleCacheClean(void) {
    FS_CACHE_Clean("");
}
```

5.1.3.3 FS_CACHE_GetNumSectors()

Description

Queries the size of the sector cache.

Prototype

```
int FS_CACHE_GetNumSectors(const char * sVolumeName,
                          U32 * pNumSectors);
```

Parameters

Parameter	Description
<code>sVolumeName</code>	Name of the volume for which the cache should be cleaned. If not specified, the first volume will be used.
<code>pNumSectors</code>	out Number of sectors that can be stored in the cache at the same time. It cannot be NULL.

Return value

= 0 OK, number of sectors returned.
 ≠ 0 An error occurred.

Additional information

This function returns the number of sectors that can be stored in the cache at the same time.

Example

```
#include "FS.h"
#include <stdio.h>

void SampleCacheGetNumSectors(void) {
    U32 NumSectors;
    char ac[100];

    FS_CACHE_GetNumSectors("", &NumSectors);
    SEGGER_sprintf(ac, sizeof(ac), "Number of sectors in cache: %lu\n", NumSectors);
    FS_X_Log(ac);
}
```

5.1.3.4 FS_CACHE_GetType()

Description

Queries the type of the configured sector cache.

Prototype

```
int FS_CACHE_GetType(const char * sVolumeName,
                    FS_CACHE_TYPE * pType);
```

Parameters

Parameter	Description
<code>sVolumeName</code>	Name of the volume for which the cache should be cleaned. If not specified, the first volume will be used.
<code>pType</code>	<p>out Cache sector type.</p> <ul style="list-style-type: none"> • <code>FS_CACHE_NONE</code> No sector cache configured. • <code>FS_CACHE_ALL</code> A pure read cache. • <code>FS_CACHE_MAN</code> A pure read cache that caches only the management sectors. • <code>FS_CACHE_RW</code> A read / write cache module. • <code>FS_CACHE_RW_QUOTA</code> A read / write cache module with configurable capacity per sector type. • <code>FS_CACHE_MULTI_WAY</code> A read / write cache module with configurable associativity level.

Return value

= 0 OK, type of sector cache returned.
 ≠ 0 An error occurred.

5.1.3.5 FS_CACHE_Invalidate()

Description

Removes all sector data from cache.

Prototype

```
int FS_CACHE_Invalidate(const char * sVolumeName);
```

Parameters

Parameter	Description
<code>sVolumeName</code>	Name of the volume for which the cache should be cleaned. If not specified, the first volume will be used.

Return value

= 0 Success, the cache has been emptied.
≠ 0 An error occurred.

Additional information

This function can be called to remove all the sectors from the cache. `FS_CACHE_Invalidate()` does not write to storage modified sector data. After calling `FS_CACHE_Invalidate()` the contents of modified sector data is lost. `FS_CACHE_Clean()` has to be called first to prevent a data loss.

Example

```
#include "FS.h"

void SampleCacheInvalidate(void) {
    FS_CACHE_Invalidate("");
}
```

5.1.3.6 FS_CACHE_SetAssocLevel()

Description

Modifies the associativity level of multi-way cache.

Prototype

```
int FS_CACHE_SetAssocLevel(const char * sVolumeName,
                          int      AssocLevel);
```

Parameters

Parameter	Description
<code>sVolumeName</code>	Name of the volume for which the cache should be cleaned. If not specified, the first volume will be used.
<code>AssocLevel</code>	Number of entries in the cache. It has to be a power of two value.

Return value

= 0 OK, associativity level set.
 ≠ 0 An error occurred.

Additional information

This function is supported only by the `FS_CACHE_MULTI_WAY` cache module. An error is returned if the function is used with any other cache module.

The associativity level specifies on how many different places in the cache the data of the same sector can be stored. The cache replacement policy uses this information to decide where to store the contents of a sector in the cache. Caches with higher associativity levels tend to have higher hit rates. The default associativity level is two.

Example

The following example shows how to configure the `FS_CACHE_MULTI_WAY` cache module to store the data of the same sector at 4 different places on the cache.

```
#include "FS.h"

void SampleCacheSetAssocLevel(void) {
    FS_CACHE_SetAssocLevel("", 4);
}
```

5.1.3.7 FS_CACHE_SetMode()

Description

Sets the operating mode of sector cache.

Prototype

```
int FS_CACHE_SetMode(const char * sVolumeName,
                    int      TypeMask,
                    int      ModeMask);
```

Parameters

Parameter	Description
<code>sVolumeName</code>	Name of the volume for which the cache should be cleaned. If not specified, the first volume will be used.
<code>TypeMask</code>	Specifies the types of the sectors that have to be cached. This parameter can be an OR-combination of the Sector type masks (<code>FS_SECTOR_TYPE_MASK_...</code>)
<code>ModeMask</code>	Specifies the operating mode of the cache module. This parameter can be one of the values defined as Sector cache modes (<code>FS_CACHE_MODE_...</code>)

Return value

= 0 OK, mode set.
 ≠ 0 An error occurred.

Additional information

This function is supported by the following cache types: `FS_CACHE_RW`, `FS_CACHE_RW_QUOTA`, and `FS_CACHE_MULTI_WAY`. These cache modules have to be configured using this function otherwise, neither read nor write operations are cached.

When configured in `FS_CACHE_MODE_WB` mode the cache module writes the sector data automatically to storage device if free space is required for new sector data. The application can call the `FS_CACHE_Clean()` function at any time to write all the cache sector data to storage device.

Example

The following example shows how to configure the `FS_CACHE_MULTI_WAY` cache module to use a read cache for the data sectors, a write back cache for the management and directory sectors.

```
#include "FS.h"

#define CACHE_SIZE FS_SIZEOF_CACHE_MULTI_WAY(200, 512)

static U32 _aCache[CACHE_SIZE / 4]; // Allocate RAM for the cache buffer.

void SampleCacheSetMode(void) {
    //
    // Assign a cache to the first available storage device.
    //
    FS_AssignCache("", _aCache, sizeof(_aCache), FS_CACHE_MULTI_WAY);
    //
    // Configure a read cache for the sectors that store file data.
    //
    FS_CACHE_SetMode("", FS_SECTOR_TYPE_MASK_DATA, FS_CACHE_MODE_R);
    //
    // Configure a write back cache for the sectors that store directory
    // and allocation table entries.
    //
    FS_CACHE_SetMode("",
```

```
        FS_SECTOR_TYPE_MASK_DIR | FS_SECTOR_TYPE_MASK_MAN,  
        FS_CACHE_MODE_WB);  
  
    //  
    // Access the file system with sector cache.  
    //  
  
    //  
    // Disable the cache.  
    //  
    FS_AssignCache("", 0, 0, FS_CACHE_NONE);  
}
```

5.1.3.8 FS_CACHE_SetQuota()

Description

Sets the quotas of a specific sector cache.

Prototype

```
int FS_CACHE_SetQuota(const char * sVolumeName,
                    int      TypeMask,
                    U32      NumSectors);
```

Parameters

Parameter	Description
<code>sVolumeName</code>	Name of the volume for which the cache should be cleaned. If not specified, the first volume will be used.
<code>TypeMask</code>	Specifies the types of the sectors that have to be cached. This parameter can be an OR-combination of the Sector type masks (<code>FS_SECTOR_TYPE_MASK_...</code>)
<code>NumSectors</code>	Specifies the maximum number of sectors to be stored for each sector type specified in <code>TypeMask</code> .

Return value

= 0 OK, maximum number of sectors set.
 ≠ 0 An error occurred.

Additional information

This function is currently only usable with the `FS_CACHE_RW_QUOTA` cache module. After the `FS_CACHE_RW_QUOTA` cache module has been assigned to a volume and the cache mode has been set, the quotas for the different sector types have to be configured using this function. Otherwise, neither read nor write operations are cached.

Example

The following example shows how to configure the `FS_CACHE_RW_QUOTA` cache module to limit the number of directory and data sector types to a maximum of 10 each.

```
#include "FS.h"

#define CACHE_SIZE    FS_SIZEOF_CACHE_RW_QUOTA(200, 512)

static U32 _acCache[CACHE_SIZE / 4]; // Allocate RAM for the cache buffer.

void SampleCacheSetQuota(void) {
    //
    // Assign a cache to the first available storage device.
    //
    FS_AssignCache("", _acCache, sizeof(_acCache), FS_CACHE_RW_QUOTA);
    //
    // Configure the cache module to cache all sectors. The sector data is cached
    // for read and write. Write operation to storage device are delayed.
    //
    FS_CACHE_SetMode("", FS_SECTOR_TYPE_MASK_ALL, FS_CACHE_MODE_WB);
    //
    // Set the maximum number of sectors to cache for directory
    // and data sector types 10 sectors each.
    //
    FS_CACHE_SetQuota("", FS_SECTOR_TYPE_MASK_DATA | FS_SECTOR_TYPE_MASK_DIR, 10);

    //
    // Access the file system with sector cache.
    //
    //
```

```
// Make sure that the data is written to storage device.
//
FS_CACHE_Clean("");

//
// Perform other accesses to file system with sector cache.
//

//
// Disable the cache.
//
FS_AssignCache("", 0, 0, FS_CACHE_NONE);
}
```

5.1.3.9 Sector cache types

Description

Types of sector caches.

Definition

```
#define FS_CACHE_NONE          NULL
#define FS_CACHE_ALL          FS_CacheAll_Init
#define FS_CACHE_MAN          FS_CacheMan_Init
#define FS_CACHE_RW           FS_CacheRW_Init
#define FS_CACHE_RW_QUOTA     FS_CacheRWQuota_Init
#define FS_CACHE_MULTI_WAY    FS_CacheMultiWay_Init
```

Symbols

Definition	Description
FS_CACHE_NONE	Pseudo-type that can be used to disable the sector cache.
FS_CACHE_ALL	A pure read cache.
FS_CACHE_MAN	A pure read cache that caches only the management sectors.
FS_CACHE_RW	A read / write cache module.
FS_CACHE_RW_QUOTA	A read / write cache module with configurable capacity per sector type.
FS_CACHE_MULTI_WAY	A read / write cache module with configurable associativity level.

Additional information

The type of a cache module can be configured via `FS_AssignCache()` function when the sector cache is enabled for a specified volume.

5.1.3.10 Sector cache modes

Description

Operating modes of sector caches.

Definition

```
#define FS_CACHE_MODE_R      0x01u
#define FS_CACHE_MODE_WT    (FS_CACHE_MODE_R | FS_CACHE_MODE_W)
#define FS_CACHE_MODE_WB    (FS_CACHE_MODE_R | FS_CACHE_MODE_W | FS_CACHE_MODE_D)
```

Symbols

Definition	Description
FS_CACHE_MODE_R	Pure read cache.
FS_CACHE_MODE_WT	Write-through cache.
FS_CACHE_MODE_WB	Write-back cache.

Additional information

The operating mode of a cache module can be configured via the `FS_CACHE_SetMode()` function separately for each sector type.

5.1.3.11 Sector cache size

Description

Calculates the cache size.

Definition

```
#define FS_SIZEOF_CACHE_ALL(NumSectors,          SectorSize)
  (FS_SIZEOF_CACHE_ALL_DATA +                  \
   (FS_SIZEOF_CACHE_ALL_BLOCK_INFO +          \
    (SectorSize)) * (NumSectors))
#define FS_SIZEOF_CACHE_MAN(NumSectors,          SectorSize)
  (FS_SIZEOF_CACHE_MAN_DATA +                  \
   (FS_SIZEOF_CACHE_MAN_BLOCK_INFO +          \
    (SectorSize)) * (NumSectors))
#define FS_SIZEOF_CACHE_RW(NumSectors,          SectorSize)
  (FS_SIZEOF_CACHE_RW_DATA +                  \
   (FS_SIZEOF_CACHE_RW_BLOCK_INFO +          \
    (SectorSize)) * (NumSectors))
#define FS_SIZEOF_CACHE_RW_QUOTA(NumSectors,    SectorSize)
  (FS_SIZEOF_CACHE_RW_QUOTA_DATA +            \
   (FS_SIZEOF_CACHE_RW_QUOTA_BLOCK_INFO +    \
    (SectorSize)) * (NumSectors))
#define FS_SIZEOF_CACHE_MULTI_WAY(NumSectors,   SectorSize)
  (FS_SIZEOF_CACHE_MULTI_WAY_DATA +          \
   (FS_SIZEOF_CACHE_MULTI_WAY_BLOCK_INFO +   \
    (SectorSize)) * (NumSectors))
#define FS_SIZEOF_CACHE_ANY(NumSectors,         SectorSize)
  FS_SIZEOF_CACHE_RW_QUOTA(NumSectors, SectorSize)
```

Symbols

Definition	Description
FS_SIZEOF_CACHE_ALL(NumSectors,	Calculates the cache size of a FS_CACHE_ALL cache module.
FS_SIZEOF_CACHE_MAN(NumSectors,	Calculates the cache size of a FS_CACHE_MAN cache module.
FS_SIZEOF_CACHE_RW(NumSectors,	Calculates the cache size of a FS_CACHE_RW cache module.
FS_SIZEOF_CACHE_RW_QUOTA(NumSectors,	Calculates the cache size of a FS_CACHE_RW_QUOTA cache module.
FS_SIZEOF_CACHE_MULTI_WAY(NumSectors,	Calculates the cache size of a FS_CACHE_MULTI_WAY cache module.
FS_SIZEOF_CACHE_ANY(NumSectors,	Calculates the size of cache that works with any cache module.

Additional information

These defines can be used to calculate the size of the memory area to be assigned to a cache module based on the size of a sector (`SectorSize`) and the number of sectors to be cached (`NumSectors`). The sector size of a specific volume can be queried via `FS_GetVolumeInfo()`.

5.1.3.12 Sector data flags

Description

Type of data stored in a logical sector.

Definition

```
#define FS_SECTOR_TYPE_MASK_DATA      (1u << FS_SECTOR_TYPE_DATA)
#define FS_SECTOR_TYPE_MASK_DIR      (1u << FS_SECTOR_TYPE_DIR)
#define FS_SECTOR_TYPE_MASK_MAN      (1u << FS_SECTOR_TYPE_MAN)
#define FS_SECTOR_TYPE_MASK_ALL      (FS_SECTOR_TYPE_MASK_DATA | \
    FS_SECTOR_TYPE_MASK_DIR | \
    FS_SECTOR_TYPE_MASK_MAN)
#define FS_SECTOR_TYPE_COUNT          3u
```

Symbols

Definition	Description
<code>FS_SECTOR_TYPE_MASK_DATA</code>	Sector that stores file data.
<code>FS_SECTOR_TYPE_MASK_DIR</code>	Sector that stores directory entries.
<code>FS_SECTOR_TYPE_MASK_MAN</code>	Sector that stores entries of the allocation table.
<code>FS_SECTOR_TYPE_MASK_ALL</code>	All sector types.
<code>FS_SECTOR_TYPE_COUNT</code>	Number of sector types (for internal use only)

Additional information

These flags are typically used with the sector cache API functions to specify the type of sector data for which a specified parameter applies. The bit positions of the flags correspond to the values defined via *Sector data type* on page 309

5.1.4 Performance and resource usage

5.1.4.1 Performance

The listed performance values depend on the compiler options, the compiler version, the used CPU, the storage medium and the defined cache size. The performance values have been measured on a SEGGER emPower evaluation board <https://www.segger.com/evaluate-our-software/segger/empower/> using an SD card as storage device. The test application has been compiled using SEGGER Embedded Studio IDE <https://www.segger.com/products/development-tools/embedded-studio/> but any other IDE can be used as well. The test application is provided in source code and is located in the `Application` folder of the emFile shipment.

Description of the test

- Initialize the file system.
- Perform a high-level format if required.
- Create 50 files without a cache.
- Write the time which was required for creation in the terminal I/O window.
- Enable a read and write cache.
- Create 50 files with the enabled read and write cache.
- Write the time which was required for creation in the terminal I/O window.
- Flush the cache.
- Write the time which was required for flushing in the terminal I/O window.
- Disable the cache.
- Create again 50 files without a cache.

- Write the time which was required for creation in the terminal I/O window.

Terminal output

```
Start
High-level formatting
Cache disabled
Creation of 50 files took: 16 ms
Cache enabled
Creation of 50 files took: 2 ms
Cache flush took: 0 ms
Cache disabled
Creation of 50 files took: 57 ms
Finished
```

Source code

```

/*****
*                               (c) SEGGER Microcontroller GmbH           *
*                               The Embedded Experts                     *
*                               www.segger.com                           *
*****/

----- END-OF-HEADER -----

File      : FS_SectorCache.c
Purpose   : Demonstrates how to configure and use the sector cache.

Additional information:
  Preparations:
    Works out-of-the-box with any storage device.

  Expected behavior:
    Measures the time it takes to create a number of files with
    and without the sector cache enabled. The results are output
    on the debug console.

  Sample output:
    Start
    Cache disabled
    Creation of 50 files took: 60 ms
    Cache enabled
    Creation of 50 files took: 18 ms
    Cache flush took: 0 ms
    Cache disabled
    Creation of 50 files took: 114 ms
    Finished
*/

/*****
*
*       #include Section
*
*****/

#include <string.h>
#include "FS.h"
#include "FS_OS.h"
#include "SEGGER.h"

/*****
*
*       Defines, configurable
*
*****/

#define VOLUME_NAME  ""
#define NUM_FILES   32

/*****
*
*       Static data

```

```

*
*****
*/
static U32 _aCache[0x400];
static char _aacFileName[NUM_FILES][13];
static char _ac[128];

/*****
*
*     Static code
*
*****
*/

/*****
*
*     _CreateFiles
*
*/
static void _CreateFiles(void) {
    int i;
    U32 Time;
    FS_FILE * pFile[NUM_FILES];

    Time = FS_X_OS_GetTime();
    for (i = 0; i < NUM_FILES; i++) {
        pFile[i] = FS_FOpen(&_aacFileName[i][0], "w");
    }
    Time = FS_X_OS_GetTime() - Time;
    SEGGER_sprintf(_ac, (int)sizeof(_ac), "Creation of %d files took: %d ms
\n", NUM_FILES, Time);
    FS_X_Log(_ac);
    for (i = 0; i < NUM_FILES; i++) {
        (void)FS_FClose(pFile[i]);
    }
}

/*****
*
*     Public code
*
*****
*/

/*****
*
*     MainTask
*
*/
#ifdef __cplusplus
extern "C" { /* Make sure we have C-declarations in C++ programs */
#endif
void MainTask(void);
#ifdef __cplusplus
}
#endif
void MainTask(void) {
    int i;
    U32 Time;

    FS_X_Log("Start\n");
    //
    // Initialize file system
    //
    FS_Init();
    //
    // Check if low-level format is required
    //
    (void)FS_FormatLLIfRequired(VOLUME_NAME);
    //
    // Check if volume needs to be high level formatted.
    //
    if (FS_IsHLevelFormatted(VOLUME_NAME) == 0) {
        FS_X_Log("High-level formatting\n");
        (void)FS_Format(VOLUME_NAME, NULL);
    }
    //
    // Prepare file names in advance.

```

```
//
for (i = 0; i < NUM_FILES; i++) {
    SEGGER_sprintf(_aacFileName[i], (int)sizeof(_aacFileName[0]), "file%.2d.txt", i);
}
//
// Create and measure the time used to create the files with the cache enabled.
//
FS_X_Log("Cache disabled\n");
_CreateFiles();
//
// Create and measure the time used to create the files.
//
(void)FS_AssignCache(VOLUME_NAME, _aCache, (int)sizeof(_aCache), FS_CACHE_RW);
(void)FS_CACHE_SetMode(VOLUME_NAME, (int)FS_SECTOR_TYPE_MASK_ALL, (int)FS_CACHE_MODE_WB);
FS_X_Log("Cache enabled\n");
_CreateFiles();
Time = FS_X_OS_GetTime();
(void)FS_CACHE_Clean(VOLUME_NAME);
Time = FS_X_OS_GetTime() - Time;
SEGGER_sprintf(_ac, (int)sizeof(_ac), "Cache flush took: %d ms\n", Time);
FS_X_Log(_ac);
//
// Create and measure the time used to create the files with the cache disabled.
//
FS_X_Log("Cache disabled\n");
(void)FS_AssignCache(VOLUME_NAME, NULL, 0, FS_CACHE_NONE);
_CreateFiles();
FS_X_Log("Finished\n");
for(;;) {
    ;
}
}

/***** End of file *****/
```

5.2 File buffer

emFile comes with support for file buffer. A file buffer is a small memory area assigned to an opened file where the file system can store frequently accessed file data. Using a file buffer can greatly increase the performance especially when the application has to access small amounts of data.

The file buffer can be configured in different access modes. In read mode, that is only the data that is read by the application from the file is stored to file buffer or in read / write mode where the data read as well as the data written by the application is stored to file buffer. The access modes can be changed at runtime each time the file is opened via `FS_SetFileBufferFlags()` or `FS_SetFileBuffer()`.

The size of the file buffer is configurable either globally for all opened files via `FS_ConfigFileBufferDefault()` or individually for each opened file via `FS_SetFileBuffer()`.

Chapter 6

Device drivers

This chapter describes the file system components that provide access to a storage device.

6.1 General information

emFile has been designed to operate with any kind of storage device. To use a specific type of storage device with emFile, a device driver for that specific storage device is required. A device driver is a file system component that provides block access to a storage device. The device driver consists of basic I/O functions for accessing the storage device and a global table that holds pointers to these functions.

The following table lists the device drivers available in emFile.

Driver name	Acronym	Identifier	Volume name
<i>File Disk driver</i>	FILEDISK	FS_FILEDISK_Driver	"file:"
<i>CompactFlash card and IDE driver</i>	IDE	FS_IDE_Driver	"ide:"
<i>SPI MMC/SD driver</i>	MMC_SPI	FS_MMC_SPI_Driver	"mmc:"
<i>Card Mode MMC/SD driver</i>	MMC_CM	FS_MMC_CM_Driver	"mmc:"
<i>SLC1 NAND driver</i>	NAND	FS_NAND_Driver	"nand:"
<i>Universal NAND driver</i>	NAND_UNI	FS_NAND_UNI_Driver	"nand:"
<i>Sector Map NOR driver</i>	NOR	FS_NOR_Driver	"nor:"
<i>Block Map NOR driver</i>	NOR_BM	FS_NOR_BM_Driver	"nor:"
<i>System RAM Disk driver</i>	RAMDISK	FS_RAMDISK_Driver	"ram:"
<i>Universal RAM Disk driver</i>	RAMDISK_UNI	FS_RAMDISK_UNI_Driver	"ram:"
<i>Windows Drive driver</i>	WINDRIVE	FS_WINDRIVE_Driver	"win:"

By default, the file system is not configured to access any particular storage device. A device driver has to be added by the application by calling `FS_AddDevice()` in `FS_X_AddDevices()`. The file system calls `FS_X_AddDevices()` during the initialization to allow the application to configure the file system. `FS_AddDevice()` takes as parameter a pointer to a the function table of the particular device driver as specified in the "Identifier" column in the table above. It is possible to add more than one device driver to the file system if more than one storage device is present in the system or if the system uses one storage device that is partitioned.

The file system assigns a volume to each device driver added by the application. A volume is an internal structure that contains information about organization of the storage device and how to access it. The application uses the volume name as specified in the "Volume name" column in the table above to select a particular storage device. The names of the volumes are fixed and cannot be changed by the application.

If the same device driver is added to file system more than once, an unit number is used to differentiate between them. The unit number is an optional part of the volume name and it can be used by the application to access a specific storage device. Most device driver functions as well as most of the underlying hardware functions receive the unit number as the first parameter. If there are for example tow NAND flash drivers which operate as two different NAND flash devices, the first one is identified as unit 0, the second one as unit 1. If there is just a single instance (as in most systems), the unit number parameter can be ignored by the underlying hardware functions.

6.1.1 Hardware layer

Most of the device drivers require functions to access the hardware. This set of functions is called hardware layer. The implementation of the hardware layer is user responsibility. emFile comes with template and sample hardware layers that can be used as a starting point in developing a new one.

The hardware layer can be implemented in two different ways:

- Polled mode
- Interrupt-driven mode

Polled mode

In the polled mode the software actively queries the completion of the I/O operation. No operating system is required to implement the device driver in this way. The following example to demonstrate the fundamentals of an polled-driven hardware layer.

```
#include "FS.h"

/*****
 *
 *     _HW_Write
 *
 *  Function description
 *    FS hardware layer function. Writes a specified number of bytes
 *    to storage device via DMA.
 */
static int _HW_Write(U8 Unit, const U8 * pData, int NumBytes) {
    int r;

    //
    // Start transmission using DMA.
    //
    _StartDMAWrite(Unit, pData, NumBytes);
    //
    // Wait for the DMA operation to complete.
    //
    while (1) {
        if (_IsDMAOperationCompleted()) {
            r = 0;           // OK, success.
            break;
        }
        if (_IsDMAError()) {
            r = 1;           // Error, could not write data via DMA.
            break;
        }
    }
    return r;
}
```

Interrupt-driven mode

In the interrupt-driven mode the completion of an I/O operation is signaled through an interrupt. This operating mode requires the support of an operating system. The following example demonstrates the fundamentals of an interrupt-driven hardware layer.

```
#include "FS.h"
#include "FS_OS.h"

/*****
 *
 *     _IRQ_Handler
 *
 *  Function description
 *    Handles the hardware interrupt. Has to be registered
 *    as interrupt service routine.
 */
static void _IRQ_Handler(void) {
    //
    // Disable further interrupts.
    //
    _DisableInterrupts();
    //
    // Signal (wake) the waiting task.
    //
    FS_X_OS_Signal();
}
```

```

/*****
 *
 *      _HW_Write
 *
 *  Function description
 *  FS hardware layer function. Writes a specified number of bytes
 *  to storage device via DMA.
 */
static int _HW_Write(U8 Unit, const U8 * pData, int NumBytes) {
    //
    // Start transmission using DMA.
    //
    _StartDMAWrite(Unit, pData, NumBytes);
    //
    // Wait for the DMA operation to complete.
    //
    while (1) {
        if (_IsDMAOperationCompleted()) {
            r = 0;          // OK, success.
            break;
        }
        if (_IsDMAError()) {
            r = 1;         // Error, could not write data via DMA.
            break;
        }
        //
        // Wait for IRQ to signal the event and wake up the task.
        //
        r = FS_X_OS_Wait(TIMEOUT);
        if (r) {
            break;        // Error, timeout expired.
        }
    }
}

```

6.2 RAM Disk driver

6.2.1 General information

The RAM disk driver supports the use of any type of volatile and non-volatile RAM as storage. This includes the system memory as well as any RAM devices connected serially via an SPI or I2C bus using FRAM, MRAM or any other type of storage technology.

Two drivers for RAM storage are provided:

- System RAM Disk driver - Supports only system memory as storage.
- Universal RAM Disk driver - Supports system memory and serial RAM devices a storage.

A file system configuration that uses the system memory as storage is suitable for getting started using emFile because it does not require any hardware access functions to be implemented. The RAM Disk driver is also useful for testing the file system on a PC simulation.

6.2.1.1 Theory of operation

The RAM Disk driver stores the data of the logical sectors it receives from file system without modification to the memory region configured by the application via `FS_RAMDISK_Configure()`. The byte offset at which the data is stored is calculated by multiplying the index of the logical sector by the size of a logical sector. For example, the data of the logical sector with the index 7 is stored at the byte offset $7 * 512 = 3584$ assuming that the size of the logical sector is 512 bytes.

6.2.1.2 Fail-safe operation

Typically, all the file system data lost in case of an unexpected power loss if a volatile RAM device or the system memory without battery backup is used as storage. battery backup. For this reason, the fail-safety is relevant only for file system configurations that use a non-volatile RAM as storage.

Unexpected reset

In case of an unexpected reset the data will be preserved. However, if the unexpected reset interrupts a write operation, the data of the sector may contain partially invalid data.

Power failure

A power failure causes an unexpected reset and has the same effects.

6.2.1.3 Wear leveling

Typically, a RAM storage does not wear out therefore the RAM Disk driver does not perform any wear leveling.

6.2.1.4 Formatting

The storage used by the RAM Disk driver has to be formatted after each startup of the system because its contents is typically lost. Exceptions to this are file system configurations that use as storage a system memory that is backed up via a battery or a non-volatile RAM device connected serially to the MCU.

The application has to format the storage via `FS_Format()` before it can store data on it. If the application adds only one RAM Disk driver to file system, `FS_Format()` can be called with an empty string as volume name. For example, `FS_Format("", NULL)`. If more than one RAM Disk driver is added to file system, the volume name has to be specified. For example, `FS_Format("ram:0:", NULL)` for the first storage device and `FS_Format("ram:1:", NULL)` for the second.

6.2.2 System RAM Disk driver

This section describes the RAM Disk driver that can use the system memory as storage.

6.2.2.1 Supported hardware

The System RAM Disk driver can be used on any target hardware that has sufficient system memory to be used as storage.

6.2.2.2 Configuring the driver

The application has to add the System RAM Disk driver to the file system before using it. This is done by calling `FS_AddDevice()` in `FS_X_AddDevices()` with the parameter set to the function table of the System RAM Disk driver `FS_RAMDISK_Driver`.

The maximum number of System RAM Disk driver instances that can be added to file system can be configured a compile-time using the `FS_RAMDISK_MAX_NUM_UNITS` configuration define. By default, a maximum number of four System RAM Disk driver instances can be added to file system.

The application has to call `FS_RAMDISK_Configure()` for each driver instance to configure the range of the system memory to be used as storage. The specified memory range can be located on any system memory that is accessible to the CPU.

Example

```
#include <FS.h>

/*****
 *
 *   Defines, configurable
 *
 *****/
#define ALLOC_SIZE      0x1100    // Memory pool for the file system in bytes
#define NUM_SECTORS    16        // Number of sectors on the RAM storage
#define BYTES_PER_SECTOR 512     // Size of a sector in bytes

/*****
 *
 *   Static data
 *
 *****/
//
// Memory pool used for semi-dynamic allocation.
//
static U32 _aMemBlock[ALLOC_SIZE / 4];
//
// Memory to be used as storage.
//
static U32 _aRAMDisk[(NUM_SECTORS * BYTES_PER_SECTOR) / 4];

/*****
 *
 *   Public code
 *
 *****/

/*****
 *
 *   FS_X_AddDevices
 *
 *   Function description
 *   This function is called by the FS during FS_Init().
 *   It is supposed to add all devices, using primarily FS_AddDevice().
 *
 *   Note
 *   (1) Other API functions may NOT be called, since this function is called
 *       during initialization. The devices are not yet ready at this point.
 *****/
```

```

*/
void FS_X_AddDevices(void) {
    FS_AssignMemory(&aMemBlock[0], sizeof(_aMemBlock));
    //
    // Add and configure the driver.
    //
    FS_AddDevice(&FS_RAMDISK_Driver);
    FS_RAMDISK_Configure(0, _aRAMDisk, BYTES_PER_SECTOR, NUM_SECTORS);
#ifdef FS_SUPPORT_FILE_BUFFER
    //
    // Enable the file buffer to increase the performance
    // when reading/writing a small number of bytes.
    //
    FS_ConfigFileBufferDefault(BYTES_PER_SECTOR, FS_FILE_BUFFER_WRITE);
#endif // FS_SUPPORT_FILE_BUFFER
}

```

6.2.2.2.1 Compile-time configuration

The compile time configuration is realized via preprocessor defines that have to be added to the `FS_Conf.h` file which is the main configuration file of emFile. For detailed information about the configuration of emFile and of the configuration define types, refer to *Configuration of emFile* on page 1218. The System RAM disk driver does not require any hardware access functions. The following table lists the configuration defines supported by the RAM Disk driver.

Define	Default value	Type	Description
FS_RAMDISK_NUM_UNITS	4	N	Maximum number of driver instances.

6.2.2.2.1.1 FS_RAMDISK_NUM_UNITS

This define specifies the maximum number of driver instances that can be created by the application. The memory for each driver instance is allocated dynamically.

6.2.2.2.2 Runtime configuration

This section describes the functions that can be used to configure an instance of the System RAM Disk driver.

Function	Description
<code>FS_RAMDISK_Configure()</code>	Configures an instance of a System RAM disk driver.

6.2.2.2.1 FS_RAMDISK_Configure()

Description

Configures an instance of a System RAM disk driver.

Prototype

```
void FS_RAMDISK_Configure(U8      Unit,
                          void * pData,
                          U16     BytesPerSector,
                          U32     NumSectors);
```

Parameters

Parameter	Description
Unit	Index of the driver instance (0-based).
pData	Memory area to be used as storage. It cannot be NULL.
BytesPerSector	Number of bytes in a logical sector.
NumSectors	Number of logical sectors in the storage.

Additional information

The application has to call this function for each instance of the System RAM disk driver it adds to file system. `Unit` identifies the instance of the System RAM disk driver. The instance of the RAM disk driver added first to file system has the index 0, the second instance has the index 1, and so on.

`pData` has to point to a memory region that is at least `BytesPerSector * NumSectors` bytes large. The memory region can be located on any system memory that is accessible by CPU.

`BytesPerSector` has to be a power of 2 value.

Example

```
#include <FS.h>

#define NUM_SECTORS      16      // Number of sectors on the RAM storage
#define BYTES_PER_SECTOR 512    // Size of a sector in bytes

static U32 _aRAMDisk[(NUM_SECTORS * BYTES_PER_SECTOR) / 4]; // Memory to be used as storage.

/*****
 *
 *      FS_X_AddDevices
 *
 *      Function description
 *      This function is called by the FS during FS_Init().
 */
void FS_X_AddDevices(void) {
    //
    // Basic file system configuration...
    //

    //
    // Add and configure the driver.
    //
    FS_AddDevice(&FS_RAMDISK_Driver);
    FS_RAMDISK_Configure(0, _aRAMDisk, BYTES_PER_SECTOR, NUM_SECTORS);

    //
    // Additional file system configuration...
    //
}
```

6.2.2.3 Performance and resource usage

6.2.2.3.1 ROM usage

The ROM usage depends on the compiler options, the compiler version and the used CPU. The memory requirements of the System RAM Disk driver were measured as described in the section *Test procedure* on page 1283.

Usage: 500 bytes

6.2.2.3.2 Static RAM usage

Static RAM usage refers to the amount of RAM required by the System RAM Disk driver internally for all the driver instances. The number of bytes can be seen in the compiler list file of the `FS_RAMDisk.c` file.

Usage: 40 bytes

6.2.2.3.3 Dynamic RAM usage

Dynamic RAM usage is the amount of RAM allocated by the driver at runtime. Each instance of the System RAM Disk driver requires the following number of bytes:

Usage: 10 bytes

6.2.2.3.4 Performance

These performance measurements are in no way complete, but they give an approximation of the length of time required for common operations on various targets. The tests have been performed as described in the section *Performance* on page 1289. All values are given in Mbytes/sec.

CPU type	Write speed	Read speed
Atmel AT91SAM9261 (200 MHz)	128	128
LogicPD LH79520 (51 MHz)	20	20

6.2.3 Universal RAM Disk driver

This section describes the RAM Disk driver that can use the system memory as well as a serial RAM device as storage.

6.2.3.1 Supported hardware

The Universal RAM Disk driver can be used on any target hardware that has sufficient system memory to be used as storage. In addition, the driver can be used with volatile and non-volatile RAM devices that are connected to MCU via a serial bus such as SPI or I2C.

The following table shows the serial RAM devices that were tested by SEGGER or are known to be compatible with a tested device.

Device name	Storage capacity	Device type	Supported extra features
Fujitsu			
MB85RC64TA	64 Kibit	I2C	
MB85RS128TY	128 Kibit	SPI	
MB85RS1MT	1 Mibit	SPI	
MB85RS256TY	256 Kibit	SPI	
MB85RS512T	512 Kibit	SPI	
Infineon			
CY15B104QSN	4096 Mibit	SPI	extended SPI, DTR
FM24CL64B	64 Mibit	I2C	
FM24V01A	128 Mibit	I2C	
FM24V02A	256 Mibit	I2C	
FM25V02A	256 Mibit	SPI	
FM25V05	512 Mibit	SPI	
FM25V10	1 Mibit	SPI	

6.2.3.2 Configuring the driver

The application has to add the Universal RAM Disk driver to the file system before using it. This is done by calling `FS_AddDevice()` in `FS_X_AddDevices()` with the parameter set to the function table of the Universal RAM Disk driver `FS_RAMDISK_UNI_Driver`.

The maximum number of Universal RAM Disk driver instances that can be added to file system can be configured at compile-time using the `FS_RAMDISK_MAX_NUM_UNITS` configuration define. By default, a maximum number of four Universal RAM Disk driver instances can be added to file system.

In addition, the application has to configure the `RAMDISK` physical layer to be used for accessing the storage and if required the `RAMDISK` hardware layer to be used for the data transfer with the RAM device.

Example

The following configuration example uses the system memory as storage.

```
#include <FS.h>

/*****
 *
 *   Defines, configurable
 *
 *****/
*/
#define ALLOC_SIZE          0x1100    // Memory pool for the file system in bytes.
#define NUM_SECTORS        16        // Number of sectors on the RAM storage.
#define BYTES_PER_SECTOR  512       // Size of a sector in bytes.
```

```

/*****
 *
 *      Static data
 *
 *****/
//
// Memory pool used for semi-dynamic allocation.
//
static U32 _aMemBlock[ALLOC_SIZE / 4];
//
// Memory to be used as storage.
//
static U32 _aRAMDisk[(NUM_SECTORS * BYTES_PER_SECTOR) / 4];

/*****
 *
 *      Public code
 *
 *****/

/*****
 *
 *      FS_X_AddDevices
 *
 *      Function description
 *      This function is called by the FS during FS_Init().
 *      It is supposed to add all devices, using primarily FS_AddDevice().
 *
 *      Note
 *      (1) Other API functions may NOT be called, since this function is called
 *          during initialization. The devices are not yet ready at this point.
 */
void FS_X_AddDevices(void) {
    FS_AssignMemory(&_aMemBlock[0], sizeof(_aMemBlock));
    //
    // Add and configure the driver.
    //
    FS_AddDevice(&FS_RAMDISK_UNI_Driver);
    FS_RAMDISK_UNI_SetPhyType(0, &FS_RAMDISK_PHY_System);
    FS_RAMDISK_UNI_SetSectorSize(0, BYTES_PER_SECTOR);
    FS_RAMDISK_SYS_SetMemBlock(0, _aRAMDisk, sizeof(_aRAMDisk));
#ifdef FS_SUPPORT_FILE_BUFFER
    //
    // Enable the file buffer to increase the performance
    // when reading/writing a small number of bytes.
    //
    FS_ConfigFileBufferDefault(BYTES_PER_SECTOR, FS_FILE_BUFFER_WRITE);
#endif // FS_SUPPORT_FILE_BUFFER
}

```

The following configuration example uses as storage a RAM device connected via I2C.

```

#include <FS.h>
#include "FS_RAMDISK_HW_I2C_GPIO_Template.h"

/*****
 *
 *      Defines, configurable
 *
 *****/
//
#define ALLOC_SIZE          0x1100    // Memory pool for the file system in bytes.
#define NUM_SECTORS        16        // Number of sectors on the RAM storage.
#define BYTES_PER_SECTOR  512       // Size of a sector in bytes.
#define DEVICE_ADDRESS     0x50      // I2C address of the device.
#define DEVICE_SIZE        8192     // Capacity of the device in bytes.

/*****
 *
 *      Static data
 *
 *****/

```

```

*/
//
// Memory pool used for semi-dynamic allocation.
//
static U32 _aMemBlock[ALLOC_SIZE / 4];

/*****
*
*     Public code
*
*****/

/*****
*
*     FS_X_AddDevices
*
*     Function description
*     This function is called by the FS during FS_Init().
*     It is supposed to add all devices, using primarily FS_AddDevice().
*
*     Note
*     (1) Other API functions may NOT be called, since this function is called
*         during initialization. The devices are not yet ready at this point.
*/
void FS_X_AddDevices(void) {
    //
    // Give the file system memory to work with.
    //
    FS_AssignMemory(&_aMemBlock[0], sizeof(_aMemBlock));
    //
    // Add and configure the driver.
    //
    FS_AddDevice(&FS_RAMDISK_UNI_Driver);
    FS_RAMDISK_UNI_SetPhyType(0, &FS_RAMDISK_PHY_I2C);
    FS_RAMDISK_UNI_SetSectorSize(0, BYTES_PER_SECTOR);
    FS_RAMDISK_I2C_SetDeviceAddress(0, DEVICE_ADDRESS);
    FS_RAMDISK_I2C_SetDeviceSize(0, DEVICE_SIZE);
    FS_RAMDISK_I2C_SetHWType(0, &FS_RAMDISK_HW_I2C_GPIO_Template);
#ifdef FS_SUPPORT_FILE_BUFFER
    //
    // Enable the file buffer to increase the performance
    // when reading/writing a small number of bytes.
    //
    FS_ConfigFileBufferDefault(BYTES_PER_SECTOR, FS_FILE_BUFFER_WRITE);
#endif // FS_SUPPORT_FILE_BUFFER
}

```

The following configuration example uses as storage a RAM device connected via SPI.

```

#include <FS.h>
#include "FS_RAMDISK_HW_SPI_Template.h"

/*****
*
*     Defines, configurable
*
*****/

#define ALLOC_SIZE          0x1100 // Memory pool for the file system in bytes.
#define BYTES_PER_SECTOR  512     // Size of a sector in bytes.

/*****
*
*     Static data
*
*****/
static U32 _aMemBlock[ALLOC_SIZE / 4]; // Memory pool used for semi-dynamic allocation.

/*****
*
*     Public code
*
*****/

```



```

*/
/*****
*
*      FS_X_AddDevices
*
*  Function description
*  This function is called by the FS during FS_Init().
*  It is supposed to add all devices, using primarily FS_AddDevice().
*
*  Note
*  (1) Other API functions may NOT be called, since this function is called
*      during initialization. The devices are not yet ready at this point.
*/
void FS_X_AddDevices(void) {
    //
    // Give the file system memory to work with.
    //
    FS_AssignMemory(&_aMemBlock[0], sizeof(_aMemBlock));
    //
    // Add and configure the driver.
    //
    FS_AddDevice(&FS_RAMDISK_UNI_Driver);
    FS_RAMDISK_UNI_SetPhyType(0, &FS_RAMDISK_PHY_SPI);
    FS_RAMDISK_UNI_SetSectorSize(0, BYTES_PER_SECTOR);
    FS_RAMDISK_SPI_SetHWType(0, &FS_RAMDISK_HW_SPI_Template);
    FS_RAMDISK_SPI_SetDeviceList(0, &FS_RAMDISK_SPI_DeviceListAll);
    FS_RAMDISK_SPI_Allow2bitMode(0, 1);
    FS_RAMDISK_SPI_Allow4bitMode(0, 1);
#ifdef FS_SUPPORT_FILE_BUFFER
    //
    // Enable the file buffer to increase the performance
    // when reading/writing a small number of bytes.
    //
    FS_ConfigFileBufferDefault(BYTES_PER_SECTOR, FS_FILE_BUFFER_WRITE);
#endif // FS_SUPPORT_FILE_BUFFER
}

```

6.2.3.2.1 Compile-time configuration

The compile time configuration is realized via preprocessor defines that have to be added to the `FS_Conf.h` file which is the main configuration file of `emFile`. For detailed information about the configuration of `emFile` and of the configuration define types, refer to *Configuration of emFile* on page 1218. The RAM disk driver does not require any hardware access functions. The following table lists the configuration defines supported by the RAM Disk driver.

Define	Default value	Type	Description
FS_RAMDISK_DATA_BUFFER_SIZE	32	N	Number of bytes to be reserved for the data buffers used for internal operations.
FS_RAMDISK_NUM_READ_RETRIES	10	N	Configures the number of retries in case of a read error.
FS_RAMDISK_NUM_UNITS	4	N	Maximum number of driver instances.
FS_RAMDISK_VERIFY_WRITE	0	B	Enables or disables the support for checking if the write operation was successful.

6.2.3.2.1.1 FS_RAMDISK_DATA_BUFFER_SIZE

This define can be used to specify the size of the buffers used by the Universal RAM Disk driver for internal operations such as verifying if the write operation was successful. All these buffers are allocated on the stack therefore increasing the value of `FS_RAMDISK_DATA_BUFFER_SIZE` increases the stack usage while providing a better performance. `FS_RAMDISK_DATA_BUFFER_SIZE` has to be a non-zero value that is a multiple of 4.

6.2.3.2.1.2 FS_RAMDISK_NUM_READ_RETRIES

FS_RAMDISK_NUM_READ_RETRIES can be used to specify the maximum number of times the Universal RAM Disk driver repeats a read operation in case of an error. A read retry is performed each time the read function of the RAMDISK physical layer reports an error.

6.2.3.2.1.3 FS_RAMDISK_NUM_UNITS

This define specifies the maximum number of driver instances that can be created by the application. The memory for each driver instance is allocated dynamically.

6.2.3.2.1.4 FS_RAMDISK_VERIFY_WRITE

This define can be used to activate the write verification of the Universal RAM Disk driver. The write verification is performed after each write operation by reading back the modified data from storage and by comparing it with the data requested to be written. An error is reported if a difference is detected. This feature has to be enabled at runtime by calling FS_RAMDISK_UNI_SetWriteVerification().

Note

Activating the write verification can negatively affect the write performance.

6.2.3.2.2 Runtime configuration

This section describes the functions that can be used to configure an instance of the RAM Disk driver.

Function	Description
FS_RAMDISK_UNI_SetPhyType()	Configures the physical layer type.
FS_RAMDISK_UNI_SetByteRange()	Configures the range of memory to be used as storage.
FS_RAMDISK_UNI_SetSectorSize()	Configures the size of the logical sector used by the driver.
FS_RAMDISK_UNI_SetWriteVerification()	Enables or disables the checking of the data write operation.

6.2.3.2.2.1 FS_RAMDISK_UNI_SetPhyType()

Description

Configures the physical layer type.

Prototype

```
int FS_RAMDISK_UNI_SetPhyType(      U8          Unit,
                                   const FS_RAMDISK_PHY_TYPE * pPhyType);
```

Parameters

Parameter	Description
<code>Unit</code>	Index of the driver instance (0-based).
<code>pPhyType</code>	Type of physical layer. It cannot be NULL.

Return value

= 0 OK, physical layer configured successfully.
 ≠ 0 Error code indicating the failure reason.

Additional information

This function is mandatory and it has to be called once in `FS_X_AddDevices()` for each instance of the RAMDisk driver created by the application. Different instances of the RAMDisk driver are identified by the `Unit` parameter.

Permitted values for the `pPhyType` parameter are:

Identifier	Description
<code>FS_RAMDISK_PHY_System</code>	System memory.
<code>FS_RAMDISK_PHY_I2C</code>	External RAM device connected via I2C.
<code>FS_RAMDISK_PHY_SPI</code>	External RAM device connected via SPI.

6.2.3.2.2 FS_RAMDISK_UNI_SetByteRange()

Description

Configures the range of memory to be used as storage.

Prototype

```
int FS_RAMDISK_UNI_SetByteRange(U8 Unit,
                                U32 StartOff,
                                U32 NumBytes);
```

Parameters

Parameter	Description
<code>Unit</code>	Index of the driver instance (0-based).
<code>StartOff</code>	Offset of the first byte to be used as storage (0-based).
<code>NumBytes</code>	Number of bytes to be used as storage.

Return value

= 0 OK, memory range configured successfully.
 ≠ 0 Error code indicating the failure reason.

Additional information

`StartOff` is rounded up to a multiple while `NumBytes` is rounded down to a multiple of logical sector size.

If `NumBytes` is set to 0 then the memory region used as storage starts at byte offset `StartOff` and extends to the end of the storage device.

6.2.3.2.2.3 FS_RAMDISK_UNI_SetSectorSize()

Description

Configures the size of the logical sector used by the driver.

Prototype

```
int FS_RAMDISK_UNI_SetSectorSize(U8 Unit,
                                unsigned BytesPerSector);
```

Parameters

Parameter	Description
<code>Unit</code>	Index of the driver instance (0-based).
<code>BytesPerSector</code>	Logical sector size in bytes.

Return value

= 0 OK, memory range configured successfully.
≠ 0 Error code indicating the failure reason.

Additional information

This function is optional. If the size of the logical sector is not explicitly configured via `FS_RAMDISK_UNI_SetSectorSize()` then the file system uses the maximum logical sector size set via `FS_SetMaxSectorSize()`. `FS_RAMDISK_UNI_SetSectorSize()` can be called only in `FS_X_AddDevices()`.

`BytesPerSector` has to be a power of 2 value.

6.2.3.2.2.4 FS_RAMDISK_UNI_SetWriteVerification()

Description

Enables or disables the checking of the data write operation.

Prototype

```
int FS_RAMDISK_UNI_SetWriteVerification(U8 Unit,
                                       U8 OnOff);
```

Parameters

Parameter	Description
<code>Unit</code>	Index of the Universal RAM Disk driver (0-based).
<code>OnOff</code>	Specifies if the feature has to be enabled or disabled <ul style="list-style-type: none"> • =0 The write operation is not checked. • ≠0 The write operation is checked.

Return value

= 0 OK, write verification configured successfully.
 ≠ 0 Error code indicating the failure reason.

Additional information

This function is optional. It can be used to enable the checking of the written data. This is done by reading back the contents of the written data and by comparing it with the data requested to be written. Enabling this feature can negatively impact the write performance of Universal RAM Disk driver.

The write verification feature is active only when the Universal RAM Disk driver is compiled with the `FS_RAMDISK_VERIFY_WRITE` configuration define is set to 1 (default is 0) or when the `FS_DEBUG_LEVEL` configuration define is set to a value greater than or equal to `FS_DEBUG_LEVEL_CHECK_ALL`.

6.2.3.3 Additional driver functions

The functions documented in this section are optional. They can be used to get information about the status of the Universal RAM Disk driver or to directly access the data stored on a RAM device.

Function	Description
<code>FS_RAMDISK_UNI_GetDiskInfo()</code>	Gets information about the storage device.
<code>FS_RAMDISK_UNI_ReadOff()</code>	Reads a specified number of bytes from storage device.
<code>FS_RAMDISK_UNI_WriteOff()</code>	Writes a specified number of bytes to storage device.

6.2.3.3.1 FS_RAMDISK_UNI_GetDiskInfo()

Description

Gets information about the storage device.

Prototype

```
int FS_RAMDISK_UNI_GetDiskInfo(U8 Unit,  
                               FS_RAMDISK_UNI_DISK_INFO * pDiskInfo);
```

Parameters

Parameter	Description
<code>Unit</code>	Index of the driver instance (0-based).
<code>pDiskInfo</code>	<code>out</code> Storage device information. It cannot be <code>NULL</code> .

Return value

- = 0 OK, information returned successfully.
- ≠ 0 Error code indicating the failure reason.

6.2.3.3.2 FS_RAMDISK_UNI_ReadOff()

Description

Reads a specified number of bytes from storage device.

Prototype

```
int FS_RAMDISK_UNI_ReadOff(U8      Unit,
                          U32      Off,
                          void *  pData,
                          U32      NumBytes);
```

Parameters

Parameter	Description
<code>Unit</code>	Index of the driver instance (0-based).
<code>Off</code>	Byte offset to read from.
<code>pData</code>	<code>out</code> Data read from storage device. It cannot be <code>NULL</code> .
<code>NumBytes</code>	Number of bytes to be read.

Return value

= 0 OK, data read successfully.
 ≠ 0 Error code indicating the failure reason.

Additional information

`Off` has to be specified in bytes and is relative to the beginning of the storage partition configured via `FS_RAMDISK_UNI_SetByteRange()`.

6.2.3.3.3 FS_RAMDISK_UNI_WriteOff()

Description

Writes a specified number of bytes to storage device.

Prototype

```
int FS_RAMDISK_UNI_WriteOff(    U8    Unit,
                               U32    Off,
                               const void * pData,
                               U32    NumBytes);
```

Parameters

Parameter	Description
<code>Unit</code>	Index of the driver instance (0-based).
<code>Off</code>	Byte offset to write to.
<code>pData</code>	<code>out</code> Data to be written to the storage device. It cannot be NULL.
<code>NumBytes</code>	Number of bytes to be written.

Return value

= 0 OK, data written successfully.
 ≠ 0 Error code indicating the failure reason.

Additional information

`Off` has to be specified in bytes and is relative to the beginning of the storage partition configured via `FS_RAMDISK_UNI_SetByteRange()`.

6.2.3.3.4 FS_RAMDISK_UNI_DISK_INFO

Description

Management information maintained by the Universal RAM Disk driver.

Type definition

```
typedef struct {  
    U32  NumBytes;  
    U16  BytesPerSector;  
} FS_RAMDISK_UNI_DISK_INFO;
```

Structure members

Member	Description
NumBytes	Capacity of the storage device in bytes.
BytesPerSector	Size of the logical sector used by the driver in bytes.

6.2.3.4 Performance and resource usage

6.2.3.4.1 ROM usage

The ROM usage depends on the compiler options, the compiler version and the used CPU. The memory requirements of the Universal RAM Disk driver were measured as described in the section *Test procedure* on page 1283.

Usage: 600 bytes

6.2.3.4.2 Static RAM usage

Static RAM usage refers to the amount of RAM required by the Universal RAM Disk driver internally for all the driver instances. The number of bytes can be seen in the compiler list file of the `FS_RAMDISK_UNI_Drv.c` file.

Usage: 16 bytes

6.2.3.4.3 Dynamic RAM usage

Dynamic RAM usage is the amount of RAM allocated by the driver at runtime. Each instance of the Universal RAM Disk driver requires the following number of bytes:

Usage: 25 bytes

6.2.3.4.4 Performance

These performance measurements are in no way complete, but they give an approximation of the length of time required for common operations on various targets. The tests have been performed as described in the section *Performance* on page 1289. All values are given in Mbytes/sec.

CPU type	RAM device	Write speed	Read speed
ST STM32H743 (480 MHz)	Infineon CY15B104QSN (48 MHz, quad DTR)	48	64

6.2.4 RAMDISK physical layer

6.2.4.1 General information

The table below lists the RAMDISK physical layers that ship with emFile. Refer to *Configuring the driver* on page 394 and *Configuring the driver* on page 398 for more information about how to add and configure a physical layer in an application.

Physical layer identifier	Hardware layer type
FS_RAMDISK_PHY_I2C	FS_RAMDISK_HW_TYPE_I2C
FS_RAMDISK_PHY_SPI	FS_RAMDISK_HW_TYPE_SPI
FS_RAMDISK_PHY_System	Not required.

The following sections provide information about the usage and the implementation of a RAMDISK physical layer.

6.2.4.2 I2C physical layer

This physical layer supports any RAM device connected to the MCU via I2C.

The physical layer has to be configured at runtime. The following section describes how this can be done in the application.

6.2.4.2.1 Runtime configuration

The API functions listed in the following table can be used by the application to configure the behavior of the System physical layer. The application can call these function only at the file system initialization in `FS_X_AddDevices()`.

Function	Description
<code>FS_RAMDISK_I2C_SetDeviceAddress()</code>	Configures the I2C address of the storage device.
<code>FS_RAMDISK_I2C_SetDeviceSize()</code>	Configures the capacity of the storage device.
<code>FS_RAMDISK_I2C_SetHWType()</code>	Configures the HW layer for the device access.

6.2.4.2.1.1 FS_RAMDISK_I2C_SetDeviceAddress()

Description

Configures the I2C address of the storage device.

Prototype

```
int FS_RAMDISK_I2C_SetDeviceAddress(U8 Unit,  
                                     unsigned Addr);
```

Parameters

Parameter	Description
<code>Unit</code>	Index of the physical layer instance (0-based).
<code>Addr</code>	I2C address to be configured.

Return value

- = 0 OK, device address configured.
- ≠ 0 Error code indicating the failure reason.

Additional information

It is mandatory to call this function once for each configured I2C RAMDisk physical layer. The application must call it in `FS_X_AddDevices()`.

6.2.4.2.1.2 FS_RAMDISK_I2C_SetDeviceSize()

Description

Configures the capacity of the storage device.

Prototype

```
int FS_RAMDISK_I2C_SetDeviceSize(U8 Unit,  
                                U32 NumBytes);
```

Parameters

Parameter	Description
<code>Unit</code>	Index of the physical layer instance (0-based).
<code>NumBytes</code>	Device capacity to be configured.

Return value

- = 0 OK, device capacity configured.
- ≠ 0 Error code indicating the failure reason.

Additional information

It is mandatory to call this function once for each configured I2C RAMDisk physical layer. The application must call it in `FS_X_AddDevices()`.

6.2.4.2.1.3 FS_RAMDISK_I2C_SetHWType()

Description

Configures the HW layer for the device access.

Prototype

```
int FS_RAMDISK_I2C_SetHWType(          U8          Unit,
                                   const FS_RAMDISK_HW_TYPE_I2C * pHWType);
```

Parameters

Parameter	Description
<code>Unit</code>	Index of the physical layer instance (0-based).
<code>pHWType</code>	<code>in</code> HW layer to be used. It cannot be NULL.

Return value

= 0 OK, HW layer configured.
 ≠ 0 Error code indicating the failure reason.

Additional information

It is mandatory to call this function once for each configured I2C RAMDisk physical layer. The application must call it in `FS_X_AddDevices()`.

6.2.4.3 SPI physical layer

This physical layer supports any RAM device connected to the MCU via single dual, quad and octal SPI.

The physical layer has to be configured at runtime. The following section describes how this can be done in the application.

6.2.4.3.1 Runtime configuration

The API functions listed in the following table can be used by the application to configure the behavior of the System physical layer. The application can call these function only at the file system initialization in `FS_X_AddDevices()`.

Function	Description
<code>FS_RAMDISK_SPI_Allow2bitMode()</code>	Specifies if the physical layer is permitted to exchange data via two data lines.
<code>FS_RAMDISK_SPI_Allow4bitMode()</code>	Specifies if the physical layer is permitted to exchange data via four data lines.
<code>FS_RAMDISK_SPI_AllowDTRMode()</code>	Specifies if the physical layer is permitted to exchange data on both clock edges.
<code>FS_RAMDISK_SPI_SetDeviceList()</code>	Configures the type of handled serial RAM devices.
<code>FS_RAMDISK_SPI_SetHWType()</code>	Configures the HW layer for the device access.
<code>FS_RAMDISK_SPI_SetMemAddr()</code>	Configures the address in the system memory where the device is mapped.

6.2.4.3.1.1 FS_RAMDISK_SPI_Allow2bitMode()

Description

Specifies if the physical layer is permitted to exchange data via two data lines.

Prototype

```
int FS_RAMDISK_SPI_Allow2bitMode(U8 Unit,
                                  U8 OnOff);
```

Parameters

Parameter	Description
<code>Unit</code>	Index of the physical layer (0-based).
<code>OnOff</code>	Activation status of the option. <ul style="list-style-type: none"> • 0 Disable the option. • 1 Enable the option.

Return value

= 0 OK, 2 bit mode configured.
 ≠ 0 Error code indicating the failure reason.

Additional information

This function is optional. By default the data is exchanged via one data line (standard SPI). The data transfer via two data lines is used only if this type of data transfer is supported by the serial RAM device. In dual mode two bits of data are transferred with each clock period which helps improve the performance. If the serial RAM device does not support the dual mode then the data is transferred in standard mode (one data bit per clock period).

The application is permitted to call this function only at the file system initialization in `FS_X_AddDevices()`.

6.2.4.3.1.2 FS_RAMDISK_SPI_Allow4bitMode()

Description

Specifies if the physical layer is permitted to exchange data via four data lines.

Prototype

```
int FS_RAMDISK_SPI_Allow4bitMode(U8 Unit,  
                                U8 OnOff);
```

Parameters

Parameter	Description
Unit	Index of the physical layer (0-based).
OnOff	Activation status of the option. <ul style="list-style-type: none">• 0 Disable the option.• 1 Enable the option.

Return value

= 0 OK, 4 bit mode configured.
≠ 0 Error code indicating the failure reason.

Additional information

This function is optional. By default the data is exchanged via one data line (standard SPI). The data transfer via four data lines is used only if this type of data transfer is supported by the serial RAM device. In quad mode four bits of data are transferred on each clock period which helps improve the performance. If the serial RAM device does not support the quad mode then the data is transferred in dual mode if enabled and supported or in standard mode (one bit per clock period).

The application is permitted to call this function only at the file system initialization in `FS_X_AddDevices()`.

6.2.4.3.1.3 FS_RAMDISK_SPI_AllowDTRMode()

Description

Specifies if the physical layer is permitted to exchange data on both clock edges.

Prototype

```
int FS_RAMDISK_SPI_AllowDTRMode(U8 Unit,
                                U8 OnOff);
```

Parameters

Parameter	Description
<code>Unit</code>	Index of the physical layer (0-based).
<code>OnOff</code>	Activation status of the option. <ul style="list-style-type: none"> • 0 Disable the option. • 1 Enable the option.

Return value

= 0 OK, DTR mode configured.
 ≠ 0 Error code indicating the failure reason.

Additional information

This function is optional. By default the data is exchanged only on one of the clock edges (SDR mode). In DTR mode the data is transferred on each edge of the clock which helps improve the performance. The SPI RAMDISK physical layer transfers the data in DTR mode only if the used serial RAM device supports it.

The application is permitted to call this function only at the file system initialization in `FS_X_AddDevices()`.

6.2.4.3.1.4 FS_RAMDISK_SPI_SetDeviceList()

Description

Configures the type of handled serial RAM devices.

Prototype

```
int FS_RAMDISK_SPI_SetDeviceList(      U8          Unit,
                                     const FS_RAMDISK_SPI_DEVICE_LIST * pDeviceList);
```

Parameters

Parameter	Description
<code>Unit</code>	Index of the physical layer (0-based).
<code>pDeviceList</code>	List of serial RAM devices the physical layer can handle.

Return value

= 0 OK, device list successfully configured.
 ≠ 0 Error code indicating the failure reason.

Additional information

This function is optional. By default the physical layer is configured to handle Infineon (Ramtron) serial FRAM devices. Handling of serial RAM devices from other manufacturers has to be explicitly enabled via this function.

Permitted values for the `pDeviceList` parameter are:

Identifier	Description
<code>FS_NOR_SPI_DeviceListAll</code>	Enables handling of serial RAM devices from all supported manufacturers.
<code>FS_NOR_SPI_DeviceListDefault</code>	Enables handling of Infineon (Ramtron) serial RAM devices.
<code>FS_NOR_SPI_DeviceListFujitsu</code>	Enables handling of Fujitsu serial RAM devices.
<code>FS_NOR_SPI_DeviceListInfineon</code>	Enables handling of Infineon serial RAM devices.

The application can save ROM space by setting `FS_RAMDISK_DEVICE_LIST_DEFAULT` to `NULL` at compile time and by calling at runtime `FS_RAMDISK_SPI_SetDeviceList()` with the actual list of serial RAM devices that have to be handled.

The application is permitted to call this function only at the file system initialization in `FS_X_AddDevices()`.

6.2.4.3.1.5 FS_RAMDISK_SPI_SetHWType()

Description

Configures the HW layer for the device access.

Prototype

```
int FS_RAMDISK_SPI_SetHWType(          U8          Unit,
                                   const FS_RAMDISK_HW_TYPE_SPI * pHWType);
```

Parameters

Parameter	Description
<code>Unit</code>	Index of the physical layer instance (0-based).
<code>pHWType</code>	<code>in</code> HW layer to be used. It cannot be NULL.

Return value

= 0 OK, HW layer configured.
 ≠ 0 Error code indicating the failure reason.

Additional information

It is mandatory to call this function once for each configured SPI RAMDisk physical layer. The application must call it in `FS_X_AddDevices()`.

6.2.4.3.1.6 FS_RAMDISK_SPI_SetMemAddr()

Description

Configures the address in the system memory where the device is mapped.

Prototype

```
int FS_RAMDISK_SPI_SetMemAddr(U8 Unit,  
                               U32 Addr);
```

Parameters

Parameter	Description
<code>Unit</code>	Index of the physical layer instance (0-based).
<code>Addr</code>	Address in the system memory.

Return value

- = 0 OK, address successfully configured.
- ≠ 0 Error code indicating the failure reason.

Additional information

This function has to be called only in `FS_X_AddDevices()`.

6.2.4.3.1.7 RAMDISK HW layer flags

Description

Additional options for data exchanged by the SPI RAMDISK hardware layer.

Definition

```
#define FS_RAMDISK_HW_FLAG_DTR_DATA      (1uL << 0)
#define FS_RAMDISK_HW_FLAG_DTR_ADDR    (1uL << 1)
#define FS_RAMDISK_HW_FLAG_DTR_CMD     (1uL << 2)
#define FS_RAMDISK_HW_FLAG_DQS_ACTIVE  (1uL << 3)
#define FS_RAMDISK_HW_FLAG_MODE_8BIT   (1uL << 4)
```

Symbols

Definition	Description
FS_RAMDISK_HW_FLAG_DTR_DATA	Exchange the data on each clock transition.
FS_RAMDISK_HW_FLAG_DTR_ADDR	Send the address on each clock transition.
FS_RAMDISK_HW_FLAG_DTR_CMD	Send the command on each clock transition.
FS_RAMDISK_HW_FLAG_DQS_ACTIVE	Enable the data strobe signal.
FS_RAMDISK_HW_FLAG_MODE_8BIT	Send eight mode bits after the data address.

6.2.4.4 System physical layer

This physical layer supports any system memory.

The physical layer has to be configured at runtime. The following section describes how this can be done in the application.

6.2.4.4.1 Runtime configuration

The API functions listed in the following table can be used by the application to configure the behavior of the System physical layer. The application can call these function only at the file system initialization in `FS_X_AddDevices()`.

Function	Description
<code>FS_RAMDISK_SYS_SetMemBlock()</code>	Configures the memory block to be used as storage.

6.2.4.4.1.1 FS_RAMDISK_SYS_SetMemBlock()

Description

Configures the memory block to be used as storage.

Prototype

```
int FS_RAMDISK_SYS_SetMemBlock(U8      Unit,
                               void *  pData,
                               U32      NumBytes);
```

Parameters

Parameter	Description
<code>Unit</code>	Index of the physical layer instance (0-based).
<code>pData</code>	Memory area to be used as storage. It cannot be <code>NULL</code> .
<code>NumBytes</code>	Number of bytes to be used as storage.

Return value

= 0 OK, memory block configured.
 ≠ 0 Error code indicating the failure reason.

Additional information

The application has to call this function for each instance of the RAM disk physical layer that is added to the file system. `Unit` identifies the instance of the RAM disk physical layer. `pData` has to point to a memory region that is at least `NumBytes` bytes large. The memory region can be located on any system memory that is accessible by CPU.

6.2.4.5 Physical layer API

The physical layers that come with emFile provide support most of the popular RAM device and target MCU types. Therefore, there is typically no need to modify any of the provided RAMDISK physical layers. In most of the cases, only the RAMDISK hardware layer has to be adapted to a specific target hardware. However, when none of the provided RAMDISK physical layers are compatible with the target hardware a new RAMDISK physical layer implementation is required. This section provides information about the API of the RAMDISK physical layer that helps to create a new physical layer from scratch or to modify an existing one.

The API of the physical layer is implemented as a structure of type `FS_RAMDISK_PHY_TYPE` that contains pointers to functions. The following sections describe these functions in detail together with the data structure passed to these functions as parameters.

6.2.4.5.1 FS_RAMDISK_PHY_TYPE

Description

RAMDISK physical layer API.

Type definition

```
typedef struct {
    FS_RAMDISK_PHY_TYPE_INIT_GET_DEVICE_INFO * pfInitGetDeviceInfo;
    FS_RAMDISK_PHY_TYPE_READ_OFF           * pfReadOff;
    FS_RAMDISK_PHY_TYPE_WRITE_OFF          * pfWriteOff;
    FS_RAMDISK_PHY_TYPE_DEINIT             * pfDeInit;
} FS_RAMDISK_PHY_TYPE;
```

Structure members

Member	Description
<code>pfInitGetDeviceInfo</code>	Initializes the instance of the RAM physical layer and returns the information about the RAM device.
<code>pfReadOff</code>	Reads data from the RAM device.
<code>pfWriteOff</code>	Writes data to the RAM device.
<code>pfDeInit</code>	Frees the resources allocated by the RAM physical layer instance.

6.2.4.5.2 FS_RAMDISK_PHY_TYPE_INIT_GET_DEVICE_INFO

Description

Initializes the physical layer.

Type definition

```
typedef int FS_RAMDISK_PHY_TYPE_INIT_GET_DEVICE_INFO(U8 Unit,
    FS_RAMDISK_DEVICE_INFO * pDeviceInfo);
```

Parameters

Parameter	Description
<code>Unit</code>	Index of the RAMDISK physical layer instance (0-based)
<code>pDeviceInfo</code>	<code>out</code> Information about the NAND flash device.

Return value

= 0 OK, physical layer successfully initialized.
 ≠ 0 An error occurred.

Additional information

This function is a member of the RAMDISK physical layer API. It has to be implemented by all the RAMDISK physical layers. This is the first function of the physical layer API that is called by the Universal RAM Disk driver when the RAM device is mounted.

This function has to perform the initialization of the hardware layer, and the identification of the RAM device. If the RAM device can be handled, then the function has to fill `pDevInfo` with information about the organization of the RAM device.

6.2.4.5.3 FS_RAMDISK_PHY_TYPE_READ_OFF

Description

Reads data from a RAM device.

Type definition

```
typedef int FS_RAMDISK_PHY_TYPE_READ_OFF(U8      Unit,
                                         U32      Off,
                                         void *  pData,
                                         U32      NumBytes);
```

Parameters

Parameter	Description
<code>Unit</code>	Index of the RAMDISK physical layer instance (0-based)
<code>Off</code>	Byte offset to read from.
<code>pData</code>	<code>out</code> Data read from RAM device.
<code>NumBytes</code>	Number of bytes to be read.

Return value

= 0 OK, data read successfully.
 ≠ 0 An error occurred.

Additional information

This function is a member of the RAMDISK physical layer API. It has to be implemented by all the RAMDISK physical layers.

6.2.4.5.4 FS_RAMDISK_PHY_TYPE_WRITE_OFF

Description

Writes data to a RAM device.

Type definition

```
typedef int FS_RAMDISK_PHY_TYPE_WRITE_OFF(
    U8      Unit,
    U32     Off,
    const void * pData,
    U32     NumBytes);
```

Parameters

Parameter	Description
Unit	Index of the RAMDISK physical layer instance (0-based)
Off	Byte offset to write to.
pData	<input type="text" value="in"/> Data to be written to the RAM device.
NumBytes	Number of bytes to be written.

Return value

= 0 OK, data written.
 ≠ 0 An error occurred.

Additional information

This function is a member of the RAMDISK physical layer API. It has to be implemented by all the RAMDISK physical layers.

6.2.4.5.5 FS_RAMDISK_PHY_TYPE_DEINIT

Description

Releases the allocated resources.

Type definition

```
typedef void FS_RAMDISK_PHY_TYPE_DEINIT(U8 Unit);
```

Parameters

Parameter	Description
<code>Unit</code>	Index of the RAMDISK physical layer instance (0-based)

Additional information

This function is a member of the RAMDISK physical layer API. It has to be implemented by the all the RAMDISK physical layers that allocate resources dynamically during the initialization such as memory for the physical layer instance.

The RAMDISK driver calls this function when the file system is unmounted.

6.2.4.5.6 FS_RAMDISK_DEVICE_INFO

Description

Information about a RAM device.

Type definition

```
typedef struct {  
    U32 NumBytes;  
} FS_RAMDISK_DEVICE_INFO;
```

Structure members

Member	Description
NumBytes	Capacity of the storage device in bytes.

6.2.4.6 Resource usage

This section describes the ROM and RAM usage of the RAMDISK physical layers.

6.2.4.6.1 ROM usage

The ROM usage depends on the compiler options, the compiler version, and the used CPU. The memory requirements of the RAMDISK physical layers were measured as described in the section *Test procedure* on page 1283.

The following table lists the ROM usage of all the available RAMDISK physical layers.

Name	ROM usage(Kbytes)
I2C	0.5
SPI	1
System	0.1

6.2.4.6.2 Static RAM usage

Static RAM usage is the amount of RAM required by the driver for static variables inside the driver. The number of bytes can be seen in a compiler list file. The next table lists the static RAM usage of all the available RAMDISK physical layers.

Name	RAM usage (bytes)
I2C	16
SPI	16
System	16

6.2.4.6.3 Dynamic RAM usage

Dynamic RAM usage is the amount of RAM allocated by the physical layer at runtime. The amount of RAM required depends on the compile time and runtime configuration. The following table lists the the dynamic RAM usage of the available RAMDISK physical layers.

Name	RAM usage (bytes)
I2C	11
SPI	20
System	8

6.2.5 RAMDISK hardware layer

6.2.5.1 General information

The RAMDISK hardware layer provides functionality for accessing a RAM device via the target hardware such as GPIO, SPI, I2C, etc. The functions of the RAMDISK hardware layer are called by the RAMDISK physical layer to exchange commands and data with a RAM device. These functions are hardware dependent and therefore they have to be implemented in the application. emFile comes with template hardware layers and sample implementations for popular evaluation boards that can be used as starting point for implementing new hardware layers. The relevant files are located in the `/Sample/FS/Driver/RAM` folder of the emFile shipment.

The functions of the RAMDISK hardware layer are organized in a function table implemented as a C structure. Different hardware layer types are provided to support different ways of interfacing a RAM device. The type of hardware layer an application has to use depends on the type RAMDISK physical layer configured. The following table shows what hardware layer is required by each physical layer.

RAMDISK hardware layer	RAMDISK physical layer
FS_RAMDISK_HW_TYPE_I2C	FS_RAMDISK_PHY_I2C
FS_RAMDISK_HW_TYPE_SPI	FS_RAMDISK_PHY_SPI

6.2.5.2 Hardware layer API - FS_RAMDISK_HW_TYPE_I2C

This hardware layer supports serial RAM devices that are interfaced via I2C. The functions of this hardware layer are grouped in a structure of type `FS_RAMDISK_HW_TYPE_I2C`. The following sections describe these functions in detail.

6.2.5.2.1 FS_RAMDISK_HW_TYPE_I2C

Description

HW layer for RAM devices connected via I2C.

Type definition

```
typedef struct {
    FS_RAMDISK_HW_TYPE_I2C_INIT * pfInit;
    FS_RAMDISK_HW_TYPE_I2C_START * pfStart;
    FS_RAMDISK_HW_TYPE_I2C_STOP * pfStop;
    FS_RAMDISK_HW_TYPE_I2C_READ * pfRead;
    FS_RAMDISK_HW_TYPE_I2C_WRITE * pfWrite;
} FS_RAMDISK_HW_TYPE_I2C;
```

Structure members

Member	Description
<code>pfInit</code>	Initializes the I2C hardware.
<code>pfStart</code>	Generates a START condition on the I2C bus.
<code>pfStop</code>	Generates a STOP condition on the I2C bus.
<code>pfRead</code>	Transfers data from I2C device to MCU.
<code>pfWrite</code>	Transfers data from MCU to I2C device.

6.2.5.2.2 FS_RAMDISK_HW_TYPE_I2C_INIT

Description

Initializes the HW layer.

Type definition

```
typedef int FS_RAMDISK_HW_TYPE_I2C_INIT(U8 Unit);
```

Parameters

Parameter	Description
<code>Unit</code>	Index of the hardware layer (0-based).

Return value

= 0 OK, HW layer successfully initialized.
≠ 0 An error occurred.

6.2.5.2.3 FS_RAMDISK_HW_TYPE_I2C_START

Description

Start an I2C transaction.

Type definition

```
typedef int FS_RAMDISK_HW_TYPE_I2C_START(U8      Unit,
                                         unsigned Addr,
                                         int      IsRead);
```

Parameters

Parameter	Description
<code>Unit</code>	Index of the hardware layer (0-based).
<code>Addr</code>	Address of the device to be accessed.
<code>IsRead</code>	Type of operation to be executed. <ul style="list-style-type: none"> • 0 - Write operation. • 1 - Read operation.

Return value

= 0 OK, transaction successfully started.
 ≠ 0 An error occurred.

Additional information

This function is a member of the I2C RAMDISK hardware layer API. It has to be implemented by all the hardware layers.

6.2.5.2.4 FS_RAMDISK_HW_TYPE_I2C_STOP

Description

Ends an I2C transaction.

Type definition

```
typedef int FS_RAMDISK_HW_TYPE_I2C_STOP(U8 Unit);
```

Parameters

Parameter	Description
<code>Unit</code>	Index of the hardware layer (0-based).

Return value

= 0 OK, transaction successfully ended.
≠ 0 An error occurred.

Additional information

This function is a member of the I2C RAMDISK hardware layer API. It has to be implemented by all the hardware layers.

6.2.5.2.5 FS_RAMDISK_HW_TYPE_I2C_READ

Description

Transfers data from I2C device to MCU.

Type definition

```
typedef int FS_RAMDISK_HW_TYPE_I2C_READ(U8 Unit,  
                                         U8 * pData,  
                                         U32 NumBytes);
```

Parameters

Parameter	Description
<code>Unit</code>	Index of the hardware layer (0-based).
<code>pData</code>	<code>out</code> Data read from I2C device.
<code>NumBytes</code>	Number of bytes to transfer.

Return value

= 0 OK, data successfully transferred.
≠ 0 An error occurred.

Additional information

This function is a member of the I2C RAMDISK hardware layer API. It has to be implemented by all the hardware layers.

The function has to send a NAK after the last byte transferred.

6.2.5.2.6 FS_RAMDISK_HW_TYPE_I2C_WRITE

Description

Transfers data from MCU to I2C device.

Type definition

```
typedef int FS_RAMDISK_HW_TYPE_I2C_WRITE(      U8  Unit,  
                                              const U8 * pData,  
                                              U32  NumBytes);
```

Parameters

Parameter	Description
<code>Unit</code>	Index of the hardware layer (0-based).
<code>pData</code>	in Data written to I2C device.
<code>NumBytes</code>	Number of bytes to transfer.

Return value

= 0 OK, data successfully transferred.
≠ 0 An error occurred.

Additional information

This function is a member of the I2C RAMDISK hardware layer API. It has to be implemented by all the hardware layers.

6.2.5.2.7 Sample implementation

The following sample implementation uses the GPIOs of an ST STM32H743 MCU to interface with a I2C RAM device. This RAMDISK hardware layer was tested on the SEGGER QSPI Flash Evaluator board (<https://www.segger.com/evaluate-our-software/segger/qspi-flash-evaluator/>)

```

/*****
*                               (c) SEGGER Microcontroller GmbH                               *
*                               The Embedded Experts                                       *
*                               www.segger.com                                           *
*****/

----- END-OF-HEADER -----

File      : FS_RAMDISK_HW_I2C_GPIO_STM32H743_SEGGER_QSPI_Flash_Evaluator.c
Purpose   : Hardware layer for SEGGER QSPI Flash Evaluator
           with RAM device connected via I2C.
Literature:
  [1] RM0433 Reference manual STM32H7x3 advanced ARM-based 32-bit MCUs
  [2] STM32H753xI Errata sheet STM32H753xI rev Y device limitations
Additional information:
  The value of RAM_NUM_DELAY_LOOPS was determined by testing with
  different I2C RAM devices. The resulting maximum SCL frequency
  for a stable data transfer is about 100 kHz which is relatively
  slow compared with the 1 MHz clock frequency supported by most
  of the I2C RAM devices.
  The reason for this limitation is that the HW layer is using
  the internal pull-up resistors of the GPIO ports for the SCL
  and SDA signals. According to the datasheet of STM32H7 device
  the value of the internal pull-up resistors is about 40 kOhm.
  The frequency of SCL signal can be greatly improved by using
  external pull-up resistors of about 4.7 kOhm.

  The device select address signals (A0-2) are set to logic low.
*/

/*****
*
*      #include section
*
*****/
#include "FS.h"

/*****
*
*      Defines, configurable
*
*****/
#define RAM_NUM_DELAY_LOOPS      500 // Number of software cycles required
                                   // to generate a delay of at least
                                   // 4.7 us if the I2C device supports
                                   // standard-mode (400kHz) or of at least
                                   // 1.3 us if the I2C device support
                                   // fast-mode (1MHz).

/*****
*
*      RAM_SET_SCL
*
*      Description
*      Sets the logic level of SCL signal to high.
*/
#define RAM_SET_SCL()            GPIOF_BSRR = 1uL << RAM_SCL_BIT

/*****
*
*      RAM_CLR_SCL
*
*      Description
*      Sets the logic level of SCL signal to low.
*/
#define RAM_CLR_SCL()            GPIOF_BSRR = 1uL << (RAM_SCL_BIT + 16)

```

```

/*****
 *
 *      RAM_SET_SDA
 *
 * Description
 * Sets the logic level of SDA signal to high.
 */
#define RAM_SET_SDA()          GPIOF_BSRR = 1uL << RAM_SDA_BIT

/*****
 *
 *      RAM_CLR_SDA
 *
 * Description
 * Sets the logic level of SDA signal to high.
 */
#define RAM_CLR_SDA()          GPIOF_BSRR = 1uL << (RAM_SDA_BIT + 16)

/*****
 *
 *      RAM_SET_SDA_TO_INPUT
 *
 * Description
 * Configures the direction of the SDA signal to input.
 */
#define RAM_SET_SDA_TO_INPUT()  GPIOF_MODER &= ~(MODER_MASK << (RAM_SDA_BIT << 1));

/*****
 *
 *      RAM_SET_SDA_TO_OUTPUT
 *
 * Description
 * Configures the direction of the SDA signal to output.
 */
#define RAM_SET_SDA_TO_OUTPUT() GPIOF_MODER |= MODER_OUT << (RAM_SDA_BIT << 1)

/*****
 *
 *      RAM_GET_SDA
 *
 * Description
 * Returns the logic level of the SDA signal.
 */
#define RAM_GET_SDA()           (GPIOF_IDR & (1uL << RAM_SDA_BIT))

/*****
 *
 *      Defines, fixed
 *
 *****/

/*****
 *
 *      RAM_DELAY
 *
 * Description
 * Blocks the execution for a fixed period of time.
 */
#if RAM_NUM_DELAY_LOOPS
#define RAM_DELAY()             _Delay()
#else
#define RAM_DELAY()
#endif

/*****
 *
 *      Port B registers
 */
#define GPIOB_BASE_ADDR         0x58020400uL
#define GPIOB_MODER             (*(volatile U32 *) (GPIOB_BASE_ADDR + 0x00))
#define GPIOB_OTYPE             (*(volatile U32 *) (GPIOB_BASE_ADDR + 0x04))
#define GPIOB_OSPEEDR           (*(volatile U32 *) (GPIOB_BASE_ADDR + 0x08))
#define GPIOB_PUPDR             (*(volatile U32 *) (GPIOB_BASE_ADDR + 0x0C))
#define GPIOB_IDR               (*(volatile U32 *) (GPIOB_BASE_ADDR + 0x10))

```

```

#define GPIOB_ODR          (*(volatile U32 *) (GPIOB_BASE_ADDR + 0x14))
#define GPIOB_BSRR        (*(volatile U32 *) (GPIOB_BASE_ADDR + 0x18))
#define GPIOB_AFRL        (*(volatile U32 *) (GPIOB_BASE_ADDR + 0x20))

/*****
 *
 *      Port F registers
 */
#define GPIOF_BASE_ADDR    0x58021400uL
#define GPIOF_MODER        (*(volatile U32 *) (GPIOF_BASE_ADDR + 0x00))
#define GPIOF_OTYPE        (*(volatile U32 *) (GPIOF_BASE_ADDR + 0x04))
#define GPIOF_OSPEEDR      (*(volatile U32 *) (GPIOF_BASE_ADDR + 0x08))
#define GPIOF_PUPDR        (*(volatile U32 *) (GPIOF_BASE_ADDR + 0x0C))
#define GPIOF_IDR          (*(volatile U32 *) (GPIOF_BASE_ADDR + 0x10))
#define GPIOF_ODR          (*(volatile U32 *) (GPIOF_BASE_ADDR + 0x14))
#define GPIOF_BSRR        (*(volatile U32 *) (GPIOF_BASE_ADDR + 0x18))
#define GPIOF_AFRL        (*(volatile U32 *) (GPIOF_BASE_ADDR + 0x20))
#define GPIOF_AFRH        (*(volatile U32 *) (GPIOF_BASE_ADDR + 0x24))

/*****
 *
 *      Reset and clock control
 */
#define RCC_BASE_ADDR      0x58024400uL
#define RCC_AHB3RSTR       (*(volatile U32 *) (RCC_BASE_ADDR + 0x7C))
#define RCC_AHB3ENR        (*(volatile U32 *) (RCC_BASE_ADDR + 0xD4))
#define RCC_AHB4ENR        (*(volatile U32 *) (RCC_BASE_ADDR + 0xE0))

/*****
 *
 *      GPIO bit positions of SPI signals
 */
#define RAM_SCL_BIT        10 // Port F
#define RAM_SDA_BIT        8 // Port F
#define RAM_A0_BIT         6 // Port B
#define RAM_A1_BIT         9 // Port F
#define RAM_A2_BIT         7 // Port F
#define RAM_WP_BIT         6 // Port F

/*****
 *
 *      GPIO bits and masks
 */
#define OSPEEDR_HIGH       2uL
#define OSPEEDR_MASK       0x3uL
#define MODER_MASK         0x3uL
#define MODER_OUT          1uL
#define MODER_ALT          2uL
#define AFR_MASK           0xFuL
#define PUPDR_MASK         0x3uL
#define PUPDR_PULLUP       0x1uL

/*****
 *
 *      Masks for the peripheral enable bits
 */
#define AHB1ENR_GPIOBEN_BIT 1
#define AHB1ENR_GPIOFEN_BIT 5

/*****
 *
 *      Static code
 */

/*****
 *
 *      _Delay
 *
 *      Function description
 *      Blocks the execution for a specified time.
 *
 *      Additional information
 *      The delay time is specified via RAM_NUM_DELAY_LOOPS.
 */

```

```

static void _Delay(void) {
    volatile int i;

    for (i = 0; i < RAM_NUM_DELAY_LOOPS; ++i) {
        ;
    }
}

/*****
 *
 *      _WriteByte
 *
 * Function description
 *   Transfers 8 bits of data from MCU to I2C device.
 *
 * Parameters
 *   Data      8-bit value to be transferred.
 *
 * Return value
 *   ==0      Data accepted by the I2C device (ACK/NACK bit set to 0)
 *   !=0      Data rejected by the I2C device (ACK/NACK bit set to 1)
 */
static int _WriteByte(U8 Data) {
    int r;
    int i;

    //
    // Send data bits with MSB first.
    //
    for (i = 0; i < 8; ++i) {
        if ((Data & (1 << 7)) != 0) {
            RAM_SET_SDA();
        } else {
            RAM_CLR_SDA();
        }
        Data <<= 1;
        RAM_DELAY();           // Wait tLOW
        RAM_SET_SCL();
        RAM_DELAY();           // Wait tHIGH
        RAM_CLR_SCL();
    }
    //
    // Receive ACK/NACK.
    //
    RAM_SET_SDA_TO_INPUT();
    RAM_DELAY();           // Wait tLOW
    RAM_SET_SCL();
    RAM_DELAY();           // Wait tHIGH
    r = RAM_GET_SDA();
    RAM_CLR_SCL();
    RAM_DELAY();           // Wait tLOW
    RAM_SET_SDA_TO_OUTPUT();
    return r;
}

/*****
 *
 *      _ReadByte
 *
 * Function description
 *   Transfers 8 bits of data from I2C device to MCU.
 *
 * Parameters
 *   AckNack   Value of the ACK/NACK bit.
 *             * 0 - More data will be transferred (ACK/NACK is set to 0)
 *             * 1 - Last data to be transferred (ACK/NACK is set to 1)
 *
 * Return value
 *   Transferred 8-bit value.
 */
static U8 _ReadByte(int AckNack) {
    U8 Value;
    int i;

    //
    // Receive data bits with MSB first.

```

```

//
RAM_SET_SDA_TO_INPUT();
RAM_DELAY();           // Wait tLOW
Value = 0;
for (i = 0; i < 8; ++i) {
    RAM_SET_SCL();
    RAM_DELAY();       // Wait tHIGH
    Value <<= 1;
    if (RAM_GET_SDA() != 0) {
        Value |= 1u;
    }
    RAM_CLR_SCL();
    RAM_DELAY();       // Wait tLOW
}
//
// Send ACK/NACK.
//
if (AckNack != 0) {
    RAM_CLR_SDA();
} else {
    RAM_SET_SDA();
}
RAM_SET_SDA_TO_OUTPUT();
RAM_SET_SCL();
RAM_DELAY();           // Wait tHIGH
RAM_CLR_SCL();
return Value;
}

/*****
 *
 *      Static code (public via callback)
 *
 *****/

/*****
 *
 *      _HW_Init
 *
 *      Function description
 *      Initializes the HW layer.
 *
 *      Parameters
 *      Unit          Index of the hardware layer (0-based).
 *
 *      Return value
 *      ==0          OK, HW layer successfully initialized.
 *      !=0          An error occurred.
 */
static int _HW_Init(U8 Unit) {
    FS_USE_PARA(Unit);
    //
    // Enable the clocks of GPIO peripherals.
    //
    RCC_AHB4ENR |= 0
                | (1uL << AHB1ENR_GPIOBEN_BIT)
                | (1uL << AHB1ENR_GPIOFEN_BIT)
                ;

    //
    // Clock signal (SCL).
    //
    GPIOF_MODER  &= ~(MODER_MASK << (RAM_SCL_BIT << 1));
    GPIOF_AFRH   &= ~(AFR_MASK << ((RAM_SCL_BIT - 8) << 2));
    GPIOF_PUPDR  &= ~(PUPDR_MASK << (RAM_SCL_BIT << 1));
    GPIOF_PUPDR  |= PUPDR_PULLUP << (RAM_SCL_BIT << 1);
    GPIOF_BSRR   = 1uL << RAM_SCL_BIT;
    // Set to high logic level.
    GPIOF_OTYPE  |= 1uL << RAM_SCL_BIT;           // Set to open-drain.
    GPIOF_OSPEEDR &= ~(OSPEEDR_MASK << (RAM_SCL_BIT << 1));
    GPIOF_MODER  |= MODER_OUT << (RAM_SCL_BIT << 1);
    //
    // Data signal (SDA).
    //
    GPIOF_MODER  &= ~(MODER_MASK << (RAM_SDA_BIT << 1));
    GPIOF_AFRH   &= ~(AFR_MASK << ((RAM_SDA_BIT - 8) << 2));

```



```

GPIOF_PUPDR   &= ~(PUPDR_MASK << (RAM_SDA_BIT << 1));
GPIOF_PUPDR   |= PUPDR_PULLUP << (RAM_SDA_BIT << 1);
GPIOF_BSRR    = 1uL << RAM_SDA_BIT;
// Set to high logic level.
GPIOF_OTYPE   |= 1uL << RAM_SDA_BIT; // Set to open-drain.
GPIOF_OSPEEDR &= ~(OSPEEDR_MASK << (RAM_SDA_BIT << 1));
GPIOF_MODER   |= MODER_OUT << (RAM_SDA_BIT << 1);
//
// Address pin 0 (A0).
//
GPIOB_MODER   &= ~(MODER_MASK << (RAM_A0_BIT << 1));
GPIOB_AFR_L   &= ~(AFR_MASK << (RAM_A0_BIT << 2));
GPIOB_BSRR    = 1uL << (RAM_A0_BIT + 16); // Set to low logic level.
GPIOB_OSPEEDR &= ~(OSPEEDR_MASK << (RAM_A0_BIT << 1));
GPIOB_MODER   |= MODER_OUT << (RAM_A0_BIT << 1);
//
// Address pin 1 (A1).
//
GPIOF_MODER   &= ~(MODER_MASK << (RAM_A1_BIT << 1));
GPIOF_AFR_H   &= ~(AFR_MASK << ((RAM_A1_BIT - 8) << 2));
GPIOF_BSRR    = 1uL << (RAM_A1_BIT + 16); // Set to low logic level.
GPIOF_OSPEEDR &= ~(OSPEEDR_MASK << (RAM_A1_BIT << 1));
GPIOF_MODER   |= MODER_OUT << (RAM_A1_BIT << 1);
//
// Address pin 2 (A2).
//
GPIOF_MODER   &= ~(MODER_MASK << (RAM_A2_BIT << 1));
GPIOF_AFR_L   &= ~(AFR_MASK << (RAM_A2_BIT << 2));
GPIOF_BSRR    = 1uL << (RAM_A2_BIT + 16); // Set to low logic level.
GPIOF_OSPEEDR &= ~(OSPEEDR_MASK << (RAM_A2_BIT << 1));
GPIOF_MODER   |= MODER_OUT << (RAM_A2_BIT << 1);
//
// Write protect pin (WP).
//
GPIOF_MODER   &= ~(MODER_MASK << (RAM_WP_BIT << 1));
GPIOF_AFR_L   &= ~(AFR_MASK << (RAM_WP_BIT << 2));
GPIOF_BSRR    = 1uL << (RAM_WP_BIT + 16);
// Set to low logic level to disable the write protection.
GPIOF_OSPEEDR &= ~(OSPEEDR_MASK << (RAM_WP_BIT << 1));
GPIOF_MODER   |= MODER_OUT << (RAM_WP_BIT << 1);
return 0;
}

/*****
 *
 *      _HW_Start
 *
 *  Function description
 *      Start an I2C transaction.
 *
 *  Parameters
 *      Unit          Index of the hardware layer (0-based).
 *      Addr          Address of the device to be accessed.
 *      IsRead        Type of operation to be executed.
 *                   * 0 - Write operation.
 *                   * 1 - Read operation.
 *
 *  Return value
 *      ==0          OK, transaction successfully started.
 *      !=0          An error occurred.
 */
static int _HW_Start(U8 Unit, unsigned Addr, int IsRead) {
    int r;
    U8 AddrByte;

    FS_USE_PARA(Unit);
    AddrByte = (U8)(Addr << 1);
    if (IsRead != 0) {
        AddrByte |= 1u;
    }
    RAM_SET_SDA();
    RAM_SET_SCL();
    RAM_DELAY(); // Wait tBUF
    RAM_CLR_SDA();
    RAM_DELAY(); // Wait tHD;STA
    RAM_CLR_SCL();

```

```

r = _WriteByte(AddrByte);
if (r != 0) {
    return 1;
}
return 0;
}

/*****
*
*      _HW_Stop
*
* Function description
* Ends an I2C transaction.
*
* Parameters
* Unit          Index of the hardware layer (0-based).
*
* Return value
* ==0          OK, transaction successfully ended.
* !=0          An error occurred.
*/
static int _HW_Stop(U8 Unit) {
    FS_USE_PARA(Unit);
    RAM_CLR_SDA();
    RAM_DELAY();           // Wait tLOW
    RAM_SET_SCL();
    RAM_DELAY();           // Wait tSU;STO
    RAM_SET_SDA();
    return 0;
}

/*****
*
*      _HW_Read
*
* Function description
* Transfers data from I2C device to MCU.
*
* Parameters
* Unit          Index of the hardware layer (0-based).
* pData        [OUT] Data read from I2C device.
* NumBytes     Number of bytes to transfer.
*
* Return value
* ==0          OK, data successfully transferred.
* !=0          An error occurred.
*/
static int _HW_Read(U8 Unit, U8 * pData, U32 NumBytes) {
    FS_USE_PARA(Unit);
    if (NumBytes != 0u) {
        --NumBytes;
        if (NumBytes != 0) {
            do {
                *pData++ = _ReadByte(1);
            } while (--NumBytes != 0u);
        }
        *pData = _ReadByte(0);
    }
    return 0;
}

/*****
*
*      _HW_Write
*
* Function description
* Transfers data from MCU to I2C device.
*
* Parameters
* Unit          Index of the hardware layer (0-based).
* pData        [IN] Data written to I2C device.
* NumBytes     Number of bytes to transfer.
*
* Return value
* ==0          OK, data successfully transferred.
* !=0          An error occurred.

```

```

*/
static int _HW_Write(U8 Unit, const U8 * pData, U32 NumBytes) {
    int r;

    FS_USE_PARA(Unit);
    r = 0; // Set to indicate success.
    if (NumBytes != 0u) {
        do {
            r = _WriteByte(*pData++);
            if (r != 0) {
                break;
            }
        } while (--NumBytes != 0u);
    }
    return r;
}

/*****
*
*     Public data
*
*****/

/*****
*
*     FS_RAMDISK_HW_I2C_GPIO_STM32H743_SEGGER_QSPI_Flash_Evaluator
*/
const FS_RAMDISK_HW_TYPE_I2C FS_RAMDISK_HW_I2C_GPIO_STM32H743_SEGGER_QSPI_Flash_Evaluator = {
    _HW_Init,
    _HW_Start,
    _HW_Stop,
    _HW_Read,
    _HW_Write
};

/***** End of file *****/

```

6.2.5.3 Hardware layer API - FS_RAMDISK_HW_TYPE_SPI

This hardware layer supports serial RAM devices that are interfaced via SPI. The functions of this hardware layer are grouped in a structure of type `FS_RAMDISK_HW_TYPE_SPI`. The following sections describe these functions in detail.

6.2.5.3.1 FS_RAMDISK_HW_TYPE_SPI

Description

HW layer for RAM devices connected via SPI (single, dual, quad or octal).

Type definition

```
typedef struct {
    FS_RAMDISK_HW_TYPE_SPI_INIT      * pfInit;
    FS_RAMDISK_HW_TYPE_SPI_UNMAP     * pfUnmap;
    FS_RAMDISK_HW_TYPE_SPI_MAP       * pfMap;
    FS_RAMDISK_HW_TYPE_SPI_CONTROL   * pfControl;
    FS_RAMDISK_HW_TYPE_SPI_READ      * pfRead;
    FS_RAMDISK_HW_TYPE_SPI_WRITE     * pfWrite;
    FS_RAMDISK_HW_TYPE_SPI_LOCK      * pfLock;
    FS_RAMDISK_HW_TYPE_SPI_UNLOCK    * pfUnlock;
} FS_RAMDISK_HW_TYPE_SPI;
```

Structure members

Member	Description
<code>pfInit</code>	Initializes the hardware.
<code>pfUnmap</code>	Configures the hardware for direct access to serial RAM device.
<code>pfMap</code>	Configures the hardware for access to serial RAM device via system memory.
<code>pfControl</code>	Sends a command to serial RAM device that does not transfer any data.
<code>pfRead</code>	Transfers data from serial RAM device to MCU.
<code>pfWrite</code>	Transfers data from MCU to serial RAM device.
<code>pfLock</code>	Requests exclusive access to SPI bus.
<code>pfUnlock</code>	Releases the exclusive access to SPI bus.

6.2.5.3.2 FS_RAMDISK_HW_TYPE_SPI_INIT

Description

Initializes the SPI hardware.

Type definition

```
typedef int FS_RAMDISK_HW_TYPE_SPI_INIT(U8 Unit);
```

Parameters

Parameter	Description
<code>Unit</code>	Index of the hardware layer (0-based).

Return value

> 0 OK, frequency of the SPI clock in Hz.
= 0 An error occurred.

Additional information

This function is a member of the SPI RAMDISK hardware layer API. It has to be implemented by all the hardware layers.

This function is called by the SPI RAMDISK physical layer before any other function of the hardware layer each time the file system mounts the serial RAM deice. `FS_RAMDISK_HW_TYPE_SPI_INIT` has to perform the initialization of clock signals, GPIO ports, SPI controller, etc.

6.2.5.3.3 FS_RAMDISK_HW_TYPE_SPI_UNMAP

Description

Configures the hardware for direct access to serial RAM device.

Type definition

```
typedef int FS_RAMDISK_HW_TYPE_SPI_UNMAP(U8 Unit);
```

Parameters

Parameter	Description
Unit	Index of the hardware layer (0-based).

Return value

- = 0 OK, direct mode configured successfully.
- ≠ 0 An error occurred.

Additional information

This function is a member of the SPI RAMDISK hardware layer API. It has to be implemented by all the hardware layers.

The physical layer calls this function before it starts sending commands directly to the serial RAM device. Typically, the SPI hardware can operate in two modes: command and memory. In command mode the physical layer can access the serial RAM device directly by sending commands to it. In the memory mode the SPI hardware translates read accesses to an assigned memory region to serial RAM device read commands. In this way, the contents of the serial RAM device is mapped into this memory region.

If the command and memory mode are mutually exclusive, FS_NOR_HW_TYPE_SPIFI_UNMAP has to disable the memory mode.

6.2.5.3.4 FS_RAMDISK_HW_TYPE_SPI_MAP

Description

Configures the hardware for access to serial RAM device via system memory.

Type definition

```
typedef int FS_RAMDISK_HW_TYPE_SPI_MAP(
    U8      Unit,
    const U8      * pCmd,
    unsigned NumBytesCmd,
    const U8      * pPara,
    unsigned NumBytesPara,
    unsigned NumBytesAddr,
    U16      BusWidth,
    unsigned Flags);
```

Parameters

Parameter	Description
<code>Unit</code>	Index of the hardware layer (0-based).
<code>pCmd</code>	in Code of the command to be used for reading the data. Cannot be <code>NULL</code> .
<code>NumBytesCmd</code>	Number of bytes in the command code. Cannot be 0.
<code>pPara</code>	in Command parameters (address and dummy bytes). Can be <code>NULL</code> .
<code>NumBytesPara</code>	Total number of address and dummy bytes to be sent. Can be 0.
<code>NumBytesAddr</code>	Number of address bytes to be send. Can be 0.
<code>BusWidth</code>	Number of data lines to be used for the data transfer.
<code>Flags</code>	Options for the data exchange.

Return value

= 0 OK, memory mode configured successfully.
 ≠ 0 An error occurred.

Additional information

This function is a member of the SPI RAMDISK hardware layer API. The implementation of this function is mandatory if the SPI hardware supports the access to RAM device via system memory. If `FS_RAMDISK_HW_TYPE_SPI_MAP` is not provided then the SPI RAMDISK physical layer accesses the RAM device in command mode.

`Flags` is a bitwise-or combination of *RAMDISK HW layer flags* on page 425.

6.2.5.3.5 FS_RAMDISK_HW_TYPE_SPI_CONTROL

Description

Sends a command to serial RAM device that does not transfer any data.

Type definition

```
typedef int FS_RAMDISK_HW_TYPE_SPI_CONTROL(
    U8 Unit,
    const U8 * pCmd,
    unsigned NumBytesCmd,
    U8 BusWidth,
    unsigned Flags);
```

Parameters

Parameter	Description
Unit	Index of the hardware layer (0-based).
pCmd	in Code of the command to be sent. Cannot be NULL.
NumBytesCmd	Number of bytes in the command code. Cannot be 0.
BusWidth	Number of data lines to be used for sending the command.
Flags	Options for the data exchange.

Return value

= 0 OK, command transferred successfully.
 ≠ 0 An error occurred.

Additional information

This function is a member of the SPI RAMDISK hardware layer API. The implementation of this function is mandatory.

[Flags](#) is a bitwise-or combination of *RAMDISK HW layer flags* on page 425.

The value of [BusWidth](#) is not encoded as is the case with the other functions of this physical layer. The value specified via [BusWidth](#) is the actual number of data lines that have to be used for the data transfer of the command code. Permitted values are 1, 2, 4 and 8.

6.2.5.3.6 FS_RAMDISK_HW_TYPE_SPI_READ

Description

Transfers data from serial RAM device to MCU.

Type definition

```
typedef int FS_RAMDISK_HW_TYPE_SPI_READ(
    U8      Unit,
    const U8 * pCmd,
    unsigned NumBytesCmd,
    const U8 * pPara,
    unsigned NumBytesPara,
    unsigned NumBytesAddr,
    U8      * pData,
    unsigned NumBytesData,
    U16     BusWidth,
    unsigned Flags);
```

Parameters

Parameter	Description
<code>Unit</code>	Index of the hardware layer (0-based).
<code>pCmd</code>	in Code of the command to be sent. Cannot be <code>NULL</code> .
<code>NumBytesCmd</code>	Number of bytes in the command code. Cannot be 0.
<code>pPara</code>	in Command parameters (address and dummy bytes). Can be <code>NULL</code> .
<code>NumBytesPara</code>	Total number of address and dummy bytes to be sent. Can be 0.
<code>NumBytesAddr</code>	Number of address bytes to be send. Can be 0.
<code>pData</code>	out Data read from the serial RAM device. Can be <code>NULL</code> .
<code>NumBytesData</code>	Number of bytes to read from the serial RAM device. Can be 0.
<code>BusWidth</code>	Number of data lines to be used for the data transfer.
<code>Flags</code>	Options for the data exchange.

Return value

= 0 OK, data transferred successfully.
 ≠ 0 An error occurred.

Additional information

This function is a member of the SPI RAMDISK hardware layer API. The implementation of this function is mandatory.

The first address byte is stored at `*pPara`. `NumBytesAddr` is always smaller than or equal to `NumBytesPara`. If `NumBytesAddr` is equal to `NumBytesPara` then neither mode nor dummy bytes have to be sent. The number of dummy bytes to be generated can be calculated as `NumBytesPara - NumBytesAddr`. If the hardware generates dummy cycles instead of bytes then the number of dummy bytes has to converted to clock cycles by taking into account the number of data lines used for the data transfer of the address.

`Flags` is a bitwise-or combination of *RAMDISK HW layer flags* on page 425.

6.2.5.3.7 FS_RAMDISK_HW_TYPE_SPI_WRITE

Description

Transfers data from MCU to serial RAM device.

Type definition

```
typedef int FS_RAMDISK_HW_TYPE_SPI_WRITE(
    U8          Unit,
    const U8    * pCmd,
    unsigned    NumBytesCmd,
    const U8    * pPara,
    unsigned    NumBytesPara,
    unsigned    NumBytesAddr,
    const U8    * pData,
    unsigned    NumBytesData,
    U16         BusWidth,
    unsigned    Flags);
```

Parameters

Parameter	Description
Unit	Index of the hardware layer (0-based).
pCmd	in Code of the command to be sent. Cannot be NULL.
NumBytesCmd	Number of bytes in the command code. Cannot be 0.
pPara	in Command parameters (address and dummy bytes). Can be NULL.
NumBytesPara	Total number of address and dummy bytes to be sent. Can be 0.
NumBytesAddr	Number of address bytes to be send. Can be 0.
pData	in Data to be sent to the serial RAM device. Can be NULL.
NumBytesData	Number of bytes to be written the serial RAM device. Can be 0.
BusWidth	Number of data lines to be used for the data transfer.
Flags	Options for the data exchange.

Return value

= 0 OK, data transferred successfully.
 ≠ 0 An error occurred.

Additional information

This function is a member of the SPI RAMDISK hardware layer API. The implementation of this function is mandatory.

The first address byte is stored at [*pPara](#). [NumBytesAddr](#) is always smaller than or equal to [NumBytesPara](#).

[Flags](#) is a bitwise-or combination of *RAMDISK HW layer flags* on page 425.

6.2.5.3.8 FS_RAMDISK_HW_TYPE_SPI_LOCK

Description

Requests exclusive access to SPI bus.

Type definition

```
typedef void FS_RAMDISK_HW_TYPE_SPI_LOCK(U8 Unit);
```

Parameters

Parameter	Description
<code>Unit</code>	Index of the hardware layer (0-based).

Additional information

This function is a member of the SPIFI NOR hardware layer API. The implementation of this function is optional.

The NOR physical layer calls this function to indicate that it needs exclusive to access the NOR flash device via the SPI bus. It is guaranteed that the NOR physical layer does not attempt to exchange any data with the serial NOR flash device via the SPI bus before calling this function first. It is also guaranteed that `FS_RAMDISK_HW_TYPE_SPI_LOCK` and `FS_RAMDISK_HW_TYPE_SPI_UNLOCK` are called in pairs. Typically, this function is used for synchronizing the access to SPI bus when the SPI bus is shared between the serial NOR flash and other SPI devices.

A possible implementation would make use of an OS semaphore that is acquired in `FS_RAMDISK_HW_TYPE_SPI_LOCK` and released in `FS_RAMDISK_HW_TYPE_SPI_UNLOCK`.

6.2.5.3.9 FS_RAMDISK_HW_TYPE_SPI_UNLOCK

Description

Requests exclusive access to SPI bus.

Type definition

```
typedef void FS_RAMDISK_HW_TYPE_SPI_UNLOCK(U8 Unit);
```

Parameters

Parameter	Description
<code>Unit</code>	Index of the hardware layer (0-based).

Additional information

This function is a member of the SPIFI NOR hardware layer API. The implementation of this function is optional.

The NOR physical layer calls this function when it no longer needs to access the serial NOR flash device via the SPI bus. It is guaranteed that the NOR physical layer does not attempt to exchange any data with the serial NOR flash device via the SPI bus before calling `FS_RAMDISK_HW_TYPE_SPI_LOCK`. It is also guaranteed that `FS_RAMDISK_HW_TYPE_SPI_UNLOCK` and `FS_RAMDISK_HW_TYPE_SPI_LOCK` are called in pairs.

`FS_RAMDISK_HW_TYPE_SPI_UNLOCK` and `FS_RAMDISK_HW_TYPE_SPI_LOCK` can be used to synchronize the access to the SPI bus when other devices than the serial NOR flash are connected to it. A possible implementation would make use of an OS semaphore that is acquired `FS_RAMDISK_HW_TYPE_SPI_LOCK` and released in `FS_RAMDISK_HW_TYPE_SPI_UNLOCK`.

6.2.5.3.10 Sample implementation

The following sample implementation uses the QUADSPI controller of an ST STM32H743 MCU to interface with a SPI RAM device. This RAMDISK hardware layer was tested on the SGGGER QSPI Flash Evaluator board (<https://www.segger.com/evaluate-our-software/segger/qspi-flash-evaluator/>)

```

/*****
*
*          (c) SEGGER Microcontroller GmbH
*          The Embedded Experts
*          www.segger.com
*
*****/

----- END-OF-HEADER -----

File      : FS_RAMDISK_HW_SPI_STM32H743_SEGGER_QSPI_Flash_Evaluator.c
Purpose   : Hardware layer for SEGGER QSPI Flash Evaluator
           with RAM device connected via SPI.
Literature:
  [1] RM0433 Reference manual STM32H7x3 advanced ARM-based 32-bit MCUs
  [2] STM32H753xI Errata sheet STM32H753xI rev Y device limitations
*/

/*****
*
*          #include section
*
*****/
#include "FS.h"

/*****
*
*          Defines, configurable
*
*****/
#ifndef FS_RAMDISK_HW_PER_CLK_HZ
#define FS_RAMDISK_HW_PER_CLK_HZ          24000000    // Clock of Quad-SPI unit.
#endif

#ifndef FS_RAMDISK_HW_RAM_CLK_HZ
#define FS_RAMDISK_HW_RAM_CLK_HZ         48000000
// Frequency of the clock supplied to RAM device.
#endif

#ifndef FS_RAMDISK_HW_QUADSPI_MEM_ADDR
#define FS_RAMDISK_HW_QUADSPI_MEM_ADDR    0x90000000
// This is the start address of the memory region used by the file system

// to read the data from the serial RAM device. The hardware layer

// uses this address to invalidate the data cache.
#endif

#ifndef FS_RAMDISK_HW_USE_QUAD_MODE
#define FS_RAMDISK_HW_USE_QUAD_MODE       1
// Enables/disables the support for quad mode.
#endif

#ifndef FS_RAMDISK_HW_USE_MEM_MAP_MODE
#define FS_RAMDISK_HW_USE_MEM_MAP_MODE    1
// Enables or disables the access to the RAM device data via system memory.
#endif

#ifndef FS_RAMDISK_HW_RESET_TIME_MS
#define FS_RAMDISK_HW_RESET_TIME_MS       10
// Number milliseconds to keep the reset line low.
#endif

/*****
*
*          Defines, fixed
*
*****/

```

```

*/
/*****
*
*       QSPI registers
*/
#define QUADSPI_BASE_ADDR      0x52005000uL
#define QUADSPI_CR             (*(volatile U32 *) (QUADSPI_BASE_ADDR + 0x00))
#define QUADSPI_DCR            (*(volatile U32 *) (QUADSPI_BASE_ADDR + 0x04))
#define QUADSPI_SR             (*(volatile U32 *) (QUADSPI_BASE_ADDR + 0x08))
#define QUADSPI_FCR            (*(volatile U32 *) (QUADSPI_BASE_ADDR + 0x0C))
#define QUADSPI_DLR            (*(volatile U32 *) (QUADSPI_BASE_ADDR + 0x10))
#define QUADSPI_CCR            (*(volatile U32 *) (QUADSPI_BASE_ADDR + 0x14))
#define QUADSPI_AR             (*(volatile U32 *) (QUADSPI_BASE_ADDR + 0x18))
#define QUADSPI_ABR            (*(volatile U32 *) (QUADSPI_BASE_ADDR + 0x1C))
#define QUADSPI_DR             (*(volatile U32 *) (QUADSPI_BASE_ADDR + 0x20))
#define QUADSPI_DR_BYTE        (*(volatile U8 *) (QUADSPI_BASE_ADDR + 0x20))
#define QUADSPI_PSMKR          (*(volatile U32 *) (QUADSPI_BASE_ADDR + 0x24))
#define QUADSPI_PSMAR          (*(volatile U32 *) (QUADSPI_BASE_ADDR + 0x28))
#define QUADSPI_PIR            (*(volatile U32 *) (QUADSPI_BASE_ADDR + 0x2C))
#define QUADSPI_LPTR           (*(volatile U32 *) (QUADSPI_BASE_ADDR + 0x30))

/*****
*
*       Port B registers
*/
#define GPIOB_BASE_ADDR        0x58020400uL
#define GPIOB_MODER            (*(volatile U32 *) (GPIOB_BASE_ADDR + 0x00))
#define GPIOB_OSPEEDR          (*(volatile U32 *) (GPIOB_BASE_ADDR + 0x08))
#define GPIOB_PUPDR            (*(volatile U32 *) (GPIOB_BASE_ADDR + 0x0C))
#define GPIOB_ODR              (*(volatile U32 *) (GPIOB_BASE_ADDR + 0x14))
#define GPIOB_AFRLL            (*(volatile U32 *) (GPIOB_BASE_ADDR + 0x20))

/*****
*
*       Port F registers
*/
#define GPIOF_BASE_ADDR        0x58021400uL
#define GPIOF_MODER            (*(volatile U32 *) (GPIOF_BASE_ADDR + 0x00))
#define GPIOF_OSPEEDR          (*(volatile U32 *) (GPIOF_BASE_ADDR + 0x08))
#define GPIOF_PUPDR            (*(volatile U32 *) (GPIOF_BASE_ADDR + 0x0C))
#define GPIOF_ODR              (*(volatile U32 *) (GPIOF_BASE_ADDR + 0x14))
#define GPIOF_BSRR             (*(volatile U32 *) (GPIOF_BASE_ADDR + 0x18))
#define GPIOF_AFRLL            (*(volatile U32 *) (GPIOF_BASE_ADDR + 0x20))
#define GPIOF_AFRHH            (*(volatile U32 *) (GPIOF_BASE_ADDR + 0x24))

/*****
*
*       Reset and clock control
*/
#define RCC_BASE_ADDR          0x58024400uL
#define RCC_AHB3RSTR           (*(volatile U32 *) (RCC_BASE_ADDR + 0x7C))
#define RCC_AHB3ENR            (*(volatile U32 *) (RCC_BASE_ADDR + 0xD4))
#define RCC_AHB4ENR            (*(volatile U32 *) (RCC_BASE_ADDR + 0xE0))

/*****
*
*       System Control Block
*/
#define SCB_BASE_ADDR          0xE000E000uL
#define SCB_CCR                 (*(volatile U32 *) (SCB_BASE_ADDR + 0xD14))
// Configuration Control Register

/*****
*
*       Memory protection unit
*/
#define MPU_BASE_ADDR          0xE000ED90uL
#define MPU_TYPE                (*(volatile U32 *) (MPU_BASE_ADDR + 0x00))
#define MPU_CTRL                (*(volatile U32 *) (MPU_BASE_ADDR + 0x04))
#define MPU_RNR                 (*(volatile U32 *) (MPU_BASE_ADDR + 0x08))
#define MPU_RBAR                (*(volatile U32 *) (MPU_BASE_ADDR + 0x0C))
#define MPU_RASR                (*(volatile U32 *) (MPU_BASE_ADDR + 0x10))

/*****
*

```

```

*      Masks for the peripheral enable bits
*/
#define AHBL1ENR_GPIOBEN      1
#define AHBL1ENR_GPIOFEN     5
#define AHB3ENR_QSPIEN       14

/*****
*
*      GPIO bit positions of SPI signals
*/
#define RAM_BK1_NCS_BIT       6 // Port B
#define RAM_CLK_BIT          10 // Port F
#define RAM_BK1_D0_BIT        8 // Port F
#define RAM_BK1_D1_BIT        9 // Port F
#define RAM_BK1_D2_BIT        7 // Port F
#define RAM_BK1_D3_BIT        6 // Port F
#define RAM_MP6_BIT           3 // Port F
#define RAM_RST_BIT           11 // Port F

/*****
*
*      GPIO bits and masks
*/
#define OSPEEDR_HIGH          2uL
#define OSPEEDR_MASK          0x3uL
#define MODER_MASK            0x3uL
#define MODER_OUT              1uL
#define MODER_ALT              2uL
#define AFR_MASK               0xFuL

/*****
*
*      Quad-SPI control register
*/
#define CR_EN_BIT              0
#define CR_ABORT_BIT          1
#define CR_SSHIFT_BIT         4
#define CR_SMIE_BIT           19
#define CR_APMS_BIT           22
#define CR_PRESCALER_BIT      24
#define CR_PRESCALER_MAX      255

/*****
*
*      Quad-SPI device configuration register
*/
#define DCR_CKMODE_BIT         0
#define DCR_FSIZE_BIT         16
#define DCR_FSIZE_MAX         0x1FuL

/*****
*
*      Quad-SPI status register
*/
#define SR_TEF_BIT             0
#define SR_TCF_BIT             1
#define SR_SMF_BIT             3
#define SR_TOF_BIT             4
#define SR_BUSY_BIT            5
#define SR_FLEVEL_BIT          8
#define SR_FLEVEL_MASK        0x3FuL

/*****
*
*      Quad-SPI communication configuration register
*/
#define CCR_INSTRUCTION_BIT    0
#define CCR_IMODE_BIT          8
#define CCR_MODE_NONE          0
#define CCR_MODE_SINGLE        1uL
#define CCR_MODE_DUAL          2uL
#define CCR_MODE_QUAD          3uL
#define CCR_ADMODE_BIT         10
#define CCR_AD_SIZE_BIT        12
#define CCR_AD_SIZE_MASK       0x03uL
#define CCR_ABMODE_BIT         14

```



```

#define CCR_ABSIZE_BIT          16
#define CCR_ABSIZE_MASK        0x03uL
#define CCR_DCYC_BIT           18
#define CCR_DMODE_BIT          24
#define CCR_FMODE_BIT          26
#define CCR_FMODE_WRITE        0x0uL
#define CCR_FMODE_READ         0x1uL
#define CCR_FMODE_POLL         0x2uL
#define CCR_FMODE_MMAP         0x3uL
#define CCR_FMODE_MASK         0x3uL
#define CCR_DDRM_BIT           31

/*****
 *
 *      MPU defines
 */
#define CTRL_ENABLE_BIT        0
#define CTRL_PRIVDEFENA_BIT    2
#define RNR_REGION_MASK        0xFF
#define RASR_ENABLE_BIT        0
#define RASR_SIZE_BIT          1
#define RASR_TEX_BIT           19
#define RASR_AP_BIT            24
#define RASR_XN_BIT            28
#define RASR_AP_FULL           0x3uL
#define TYPE_DREGION_BIT       8
#define TYPE_DREGION_MASK      0xFFuL
#define RBAR_REGION_BIT        0
#define RBAR_REGION_MASK       0x1FuL
#define RBAR_VALID_BIT         5

/*****
 *
 *      Misc. defines
 */
#define NUM_BYTES_FIFO         32
#define CCR_DC_BIT             16
#define QUADSPI_MEM_SIZE_SHIFT 28
    // Size of the memory region reserved for QUADSPI (256 MB)
#define QUADSPI_PRIO           15
#define CYCLES_PER_MS           150000           // Depends on the CPU clock frequency.
#define WAIT_TIMEOUT_MS        500
#define WAIT_TIMEOUT_CYCLES    (WAIT_TIMEOUT_MS * CYCLES_PER_MS)

/*****
 *
 *      Static code
 *
 *****/

/*****
 *
 *      _CalcClockDivider
 *
 *      Function description
 *      Calculates the divider for the clock supplied to RAM device.
 */
static U8 _CalcClockDivider(U32 * pFreq_Hz) {
    U8 Div;
    U32 Freq_Hz;
    U32 MaxFreq_Hz;

    Div = 0;
    MaxFreq_Hz = *pFreq_Hz;
    for (;;) {
        Freq_Hz = FS_RAMDISK_HW_PER_CLK_HZ / (Div + 1);
        if (Freq_Hz <= MaxFreq_Hz) {
            break;
        }
        ++Div;
        if (Div == CR_PRESCALER_MAX) {
            break;
        }
    }
    *pFreq_Hz = Freq_Hz;
}

```

```

    return Div;
}

/*****
 *
 *      _GetMode
 *
 * Function description
 * Returns the transfer mode for the QUADSPI peripheral.
 */
static U32 _GetMode(unsigned BusWidth, U32 NumBytes) {
    U32 Mode;

    Mode = CCR_MODE_NONE;
    if (NumBytes) {
        switch (BusWidth) {
            case 1:
                Mode = CCR_MODE_SINGLE;
                break;
            case 2:
                Mode = CCR_MODE_DUAL;
                break;
            case 4:
                Mode = CCR_MODE_QUAD;
                break;
            default:
                break;
        }
    }
    return Mode;
}

/*****
 *
 *      _CalcNumCycles
 *
 * Function description
 * Calculates the number of clock cycles required to transfer a specified number of bytes.
 */
static U32 _CalcNumCycles(unsigned BusWidth, U32 NumBytes, int IsDTRMode) {
    U32 NumCycles;

    NumCycles = 0;
    if (NumBytes != 0) {
        NumCycles = NumBytes << 3;           // Assume 8-bits per byte.
        switch (BusWidth) {
            case 2:
                NumCycles >>= 1;
                break;
            case 4:
                NumCycles >>= 2;
                break;
            default:
                break;
        }
        if (IsDTRMode != 0) {
            NumCycles >>= 1;                 // The data is sent on both clock edges.
        }
    }
    return NumCycles;
}

/*****
 *
 *      _ClearFlags
 *
 * Function description
 * Clears the status flags of QUADSPI peripheral.
 */
static int _ClearFlags(void) {
    U32 TimeOut;
    int r;

    QUADSPI_FCR = 0
        | (1uL << SR_TEF_BIT)
        | (1uL << SR_TCF_BIT)

```

```

        | (1uL << SR_SMF_BIT)
        | (1uL << SR_TOF_BIT)
        ;

//
// Wait for the flags to be cleared.
//
r      = 0;
TimeOut = WAIT_TIMEOUT_CYCLES;
for (;;) {
    if ((QUADSPI_SR & ((1uL << SR_TEF_BIT) |
                       (1uL << SR_TCF_BIT) |
                       (1uL << SR_SMF_BIT) |
                       (1uL << SR_TOF_BIT))) == 0) {

        break;
    }
    if (--TimeOut == 0u) {
        r = 1;
        break;
    }
}
return r;
}

/*****
 *
 *      _Cancel
 *
 * Function description
 * Interrupts an ongoing data transfer.
 */
static int _Cancel(void) {
    U32 TimeOut;
    int r;

    r      = 0;
    TimeOut = WAIT_TIMEOUT_CYCLES;
    QUADSPI_CR |= 1uL << CR_ABORT_BIT;
    for (;;) {
        if ((QUADSPI_CR & (1uL << CR_ABORT_BIT)) == 0) {
            break;
        }
        if (--TimeOut == 0u) {
            r = 1;
            break;
        }
    }
    return r;
}

/*****
 *
 *      _DisabledDCache
 *
 * Function description
 * Disables the data cache for the memory region where the RAM device is mapped.
 */
static void _DisabledDCache(void) {
    U32 NumRegions;
    U32 iRegion;
    U32 Mask;

    if (SCB_CCR & (1uL << CCR_DC_BIT)) { // Is data cache enabled?
        NumRegions = (MPU_TYPE >> TYPE_DREGION_BIT) & TYPE_DREGION_MASK;
        //
        // Find the next free region.
        //
        for (iRegion = 0; iRegion < NumRegions; ++iRegion) {
            MPU_RNR = iRegion;
            if ((MPU_RASR & (1uL << RASR_ENABLE_BIT)) == 0) {
                break; // Found a free region.
            }
            //
            // Check if we already configured the MPU.
            //
            Mask = 0uL
                | (RBAR_REGION_MASK << RBAR_REGION_BIT)

```

```

        | (1uL << RBAR_VALID_BIT)
        ;
    if ((MPU_RBAR & ~Mask) == FS_RAMDISK_HW_QUADSPI_MEM_ADDR) {
        iRegion = NumRegions;
        break; // Already configured.
    }
}
if (iRegion < NumRegions) {
    //
    // Use MPU to disable the data cache on the memory region assigned to QSPI.
    //
    MPU_CTRL &= ~(1uL << CTRL_ENABLE_BIT); // Disable MPU first.
    MPU_RNR = iRegion & RNR_REGION_MASK;
    MPU_RBAR = FS_RAMDISK_HW_QUADSPI_MEM_ADDR;
    MPU_RASR = 0
        | (1uL << RASR_XN_BIT)
        | (RASR_AP_FULL << RASR_AP_BIT)
        | (1uL << RASR_TEX_BIT)
        | ((QUADSPI_MEM_SIZE_SHIFT - 1) << RASR_SIZE_BIT)
        | (1uL << RASR_ENABLE_BIT)
        ;

    //
    // Enable MPU.
    //
    MPU_CTRL |= 0
        | (1uL << CTRL_PRIVDEFENA_BIT)
        | (1uL << CTRL_ENABLE_BIT)
        ;
}
}
}

/*****
 *
 * Static code (public via callback)
 *
 *****/

/*****
 *
 * _HW_Init
 *
 * Function description
 * Initializes the SPI hardware.
 *
 * Parameters
 * Unit Index of the hardware layer (0-based).
 *
 * Return value
 * > 0 OK, frequency of the SPI clock in Hz.
 * ==0 An error occurred.
 */
static int _HW_Init(U8 Unit) {
    U32 Div;
    U32 Freq_Hz;

    FS_USE_PARA(Unit);
    //
    // Enable the clocks of peripherals and reset them.
    //
    RCC_AHB4ENR |= 0
        | (1uL << AHB1ENR_GPIOBEN)
        | (1uL << AHB1ENR_GPIOFEN)
        ;

    RCC_AHB3ENR |= 1uL << AHB3ENR_QSPIEN;
    RCC_AHB3RSTR |= 1uL << AHB3ENR_QSPIEN;
    RCC_AHB3RSTR &= ~(1uL << AHB3ENR_QSPIEN);
    //
    // Wait for the unit to exit reset.
    //
    for (;;) {
        if ((RCC_AHB3RSTR & (1uL << AHB3ENR_QSPIEN)) == 0) {
            break;
        }
    }
}

```

```

//
// Disable the cache on the memory region assigned to QSPI.
//
_DisableDCache();
//
// NCS of bank 1 is an output signal and is controlled by the QUADSPI unit.
//
GPIOB_MODER   &= ~(MODER_MASK   << (RAM_BK1_NCS_BIT << 1));
GPIOB_MODER   |=  MODER_ALT     << (RAM_BK1_NCS_BIT << 1);
GPIOB_AFRL    &= ~(AFR_MASK     << (RAM_BK1_NCS_BIT << 2));
GPIOB_AFRL    |=  0xAuL        << (RAM_BK1_NCS_BIT << 2);
GPIOB_OSPEEDR &= ~(OSPEEDR_MASK << (RAM_BK1_NCS_BIT << 1));
GPIOB_OSPEEDR |=  OSPEEDR_HIGH << (RAM_BK1_NCS_BIT << 1);
//
// CLK is an output signal controlled by the QUADSPI unit.
//
GPIOF_MODER   &= ~(MODER_MASK   << (RAM_CLK_BIT << 1));
GPIOF_MODER   |=  MODER_ALT     << (RAM_CLK_BIT << 1);
GPIOF_AFRH    &= ~(AFR_MASK     << ((RAM_CLK_BIT - 8) << 2));
GPIOF_AFRH    |=  0x9uL        << ((RAM_CLK_BIT - 8) << 2);
GPIOF_OSPEEDR &= ~(OSPEEDR_MASK << (RAM_CLK_BIT << 1));
GPIOF_OSPEEDR |=  OSPEEDR_HIGH << (RAM_CLK_BIT << 1);
//
// D0 of bank 1 is an input/output signal controlled by the QUADSPI unit.
//
GPIOF_MODER   &= ~(MODER_MASK   << (RAM_BK1_D0_BIT << 1));
GPIOF_MODER   |=  MODER_ALT     << (RAM_BK1_D0_BIT << 1);
GPIOF_AFRH    &= ~(AFR_MASK     << ((RAM_BK1_D0_BIT - 8) << 2));
GPIOF_AFRH    |=  0xAuL        << ((RAM_BK1_D0_BIT - 8) << 2);
GPIOF_OSPEEDR &= ~(OSPEEDR_MASK << (RAM_BK1_D0_BIT << 1));
GPIOF_OSPEEDR |=  OSPEEDR_HIGH << (RAM_BK1_D0_BIT << 1);
//
// D1 of bank 1 is an input/output signal controlled by the QUADSPI unit.
//
GPIOF_MODER   &= ~(MODER_MASK   << (RAM_BK1_D1_BIT << 1));
GPIOF_MODER   |=  MODER_ALT     << (RAM_BK1_D1_BIT << 1);
GPIOF_AFRH    &= ~(AFR_MASK     << ((RAM_BK1_D1_BIT - 8) << 2));
GPIOF_AFRH    |=  0xAuL        << ((RAM_BK1_D1_BIT - 8) << 2);
GPIOF_OSPEEDR &= ~(OSPEEDR_MASK << (RAM_BK1_D1_BIT << 1));
GPIOF_OSPEEDR |=  OSPEEDR_HIGH << (RAM_BK1_D1_BIT << 1);
#if FS_RAMDISK_HW_USE_QUAD_MODE
//
// D2 of bank 1 is an input/output signal and is controlled by the QUADSPI unit.
//
GPIOF_MODER   &= ~(MODER_MASK   << (RAM_BK1_D2_BIT << 1));
GPIOF_MODER   |=  MODER_ALT     << (RAM_BK1_D2_BIT << 1);
GPIOF_AFRL    &= ~(AFR_MASK     << (RAM_BK1_D2_BIT << 2));
GPIOF_AFRL    |=  0x9uL        << (RAM_BK1_D2_BIT << 2);
GPIOF_OSPEEDR &= ~(OSPEEDR_MASK << (RAM_BK1_D2_BIT << 1));
GPIOF_OSPEEDR |=  OSPEEDR_HIGH << (RAM_BK1_D2_BIT << 1);
//
// D3 of bank 1 is an output signal and is controlled by the QUADSPI unit.
//
GPIOF_MODER   &= ~(MODER_MASK   << (RAM_BK1_D3_BIT << 1));
GPIOF_MODER   |=  MODER_ALT     << (RAM_BK1_D3_BIT << 1);
GPIOF_AFRL    &= ~(AFR_MASK     << (RAM_BK1_D3_BIT << 2));
GPIOF_AFRL    |=  0x9uL        << (RAM_BK1_D3_BIT << 2);
GPIOF_OSPEEDR &= ~(OSPEEDR_MASK << (RAM_BK1_D3_BIT << 1));
GPIOF_OSPEEDR |=  OSPEEDR_HIGH << (RAM_BK1_D3_BIT << 1);
#else
//
// D2 and D3 are used as WP and HOLD signals when the quad mode
// is disabled in the RAM device. We set these signals to
// logic high here so that the data transfer works correctly
// in single and dual mode.
//
GPIOF_BSRR    = 1uL << RAM_BK1_D2_BIT;
GPIOF_MODER   &= ~(MODER_MASK   << (RAM_BK1_D2_BIT << 1));
GPIOF_MODER   |=  MODER_OUT     << (RAM_BK1_D2_BIT << 1);
GPIOF_AFRL    &= ~(AFR_MASK     << (RAM_BK1_D2_BIT << 2));
GPIOF_OSPEEDR &= ~(OSPEEDR_MASK << (RAM_BK1_D2_BIT << 1));
GPIOF_BSRR    = 1uL << RAM_BK1_D3_BIT;
GPIOF_MODER   &= ~(MODER_MASK   << (RAM_BK1_D3_BIT << 1));
GPIOF_MODER   |=  MODER_OUT     << (RAM_BK1_D3_BIT << 1);
GPIOF_AFRL    &= ~(AFR_MASK     << (RAM_BK1_D3_BIT << 2));
GPIOF_OSPEEDR &= ~(OSPEEDR_MASK << (RAM_BK1_D3_BIT << 1));

```

```

#endif // FS_RAMDISK_HW_USE_QUAD_MODE
//
// The MP6 is the signal connected to the pin 6 of the RAM device
// which is used by some dual stack devices as the chip select signal
// for the second stack. We have to disable the second stack
// by setting the MP6 signal to high in order to prevent that the
// second stack is accidentally activated.
//
GPIOF_BSRR = 1uL << RAM_MP6_BIT;
GPIOF_MODER &= ~(MODER_MASK << (RAM_MP6_BIT << 1));
GPIOF_MODER |= MODER_OUT << (RAM_MP6_BIT << 1);
GPIOF_AFRH &= ~(AFR_MASK << (RAM_MP6_BIT << 2));
GPIOF_OSPEEDR &= ~(OSPEEDR_MASK << (RAM_MP6_BIT << 1));
//
// Set the RST signal to high to make sure that the RAM
// device is not accidentally reset during the data transfer.
//
GPIOF_BSRR = 1uL << RAM_RST_BIT;
GPIOF_MODER &= ~(MODER_MASK << (RAM_RST_BIT << 1));
GPIOF_MODER |= MODER_OUT << (RAM_RST_BIT << 1);
GPIOF_AFRH &= ~(AFR_MASK << ((RAM_RST_BIT - 8) << 2));
GPIOF_OSPEEDR &= ~(OSPEEDR_MASK << (RAM_RST_BIT << 1));
//
// Initialize the Quad-SPI controller.
//
Freq_Hz = FS_RAMDISK_HW_RAM_CLK_HZ;
Div = (U32)_CalcClockDivider(&Freq_Hz);
QUADSPI_CR = 0
            | (1uL << CR_EN_BIT) // Enable the Quad-SPI unit.
            | (Div << CR_PRESCALER_BIT);
;
QUADSPI_DCR = 0
            | (1uL << DCR_CKMODE_BIT)
// CLK signal stays HIGH when the RAM device is not selected.
            | (DCR_FSIZE_MAX << DCR_FSIZE_BIT)
// We set the size of the RAM device to maximum because the actual capacity is not known at this stage.
            ;
#if FS_RAMDISK_HW_RESET_TIME_MS
{
    volatile U32 NumCycles;

    GPIOF_BSRR = 1uL << (RAM_RST_BIT + 16);
// Put the RAM device into reset state by setting the signal to low.
    NumCycles = FS_RAMDISK_HW_RESET_TIME_MS * CYCLES_PER_MS;
    do {
        ;
    } while (--NumCycles != 0u);
    GPIOF_BSRR = 1uL << RAM_RST_BIT;
// Release the RAM device from the reset state by setting reset signal to high.
    NumCycles = FS_RAMDISK_HW_RESET_TIME_MS * CYCLES_PER_MS;
    do {
        ;
    } while (--NumCycles != 0u);
}
#endif // FS_RAMDISK_HW_RESET_TIME_MS
return (int)Freq_Hz;
}

/*****
*
*      _HW_Unmap
*
* Function description
*   Enables the direct access to RAM device.
*
* Parameters
*   Unit      Index of the hardware layer (0-based).
*
* Return value
*   ==0      OK, command mode configured successfully.
*   !=0      An error occurred.
*
* Additional information
*   This function disables the memory-mapped mode.
*/
static int _HW_Unmap(U8 Unit) {

```

```

int r;

FS_USE_PARA(Unit);          // This device has only one HW unit.
r = 0;
//
// Restore the default sampling mode.
//
QUADSPI_CR &= ~(1uL << CR_SSHIFT_BIT);
//
// Cancel the memory mode so that the BUSY bit goes to 0
// and we can write to QUADSPI_CCR register.
//
if ((QUADSPI_CCR & (CCR_FMODE_MASK << CCR_FMODE_BIT)) == (CCR_FMODE_MMAP << CCR_FMODE_BIT)) {
    r = _Cancel();
}
return r;
}

#if FS_RAMDISK_HW_USE_MEM_MAP_MODE

/*****
*
*     _HW_Map
*
* Function description
*     Configures the hardware for access to serial RAM device via system memory.
*
* Parameters
*     Unit           Index of the hardware layer (0-based).
*     pCmd           [IN] Code of the command to be used for reading the data. Cannot be
NULL.
*     NumBytesCmd    Number of bytes in the command code. Cannot be 0.
*     pPara         [IN] Command parameters (address and dummy bytes). Can be NULL.
*     NumBytesPara   Total number of address and dummy bytes to be sent. Can be 0.
*     NumBytesAddr   Number of address bytes to be send. Can be 0.
*     BusWidth      Number of data lines to be used for the data transfer.
*     Flags         Options for the data exchange.
*
* Return value
*     ==0          OK, memory mode configured successfully.
*     !=0          An error occurred.
*/
static int _HW_Map(U8 Unit, const U8 * pCmd, unsigned NumBytesCmd, const U8 * pPara,
unsigned NumBytesPara, unsigned NumBytesAddr, U16 BusWidth, unsigned Flags) {
    U32 CfgReg;
    U32 CmdMode;
    U32 AddrMode;
    U32 DataMode;
    U32 NumDummyCycles;
    U32 AddrSize;
    U32 IsDTR;
    U32 AltMode;
    U32 AltSize;
    U32 NumBytesAlt;
    U32 NumBytes;
    U32 AltReg;
    int r;
    U32 TimeOut;

    FS_USE_PARA(Unit);
    // This MCU has only one QSPI controller.
    FS_USE_PARA(pPara);
    FS_DEBUG_ASSERT(FS_MTYPE_DRIVER, NumBytesCmd == 1u);
    // The QSPI controller is able to handle only 1-byte commands.
    //
    // Fill local variables.
    //
    r          = 0;
    AltReg     = 0;
    NumBytesAlt = NumBytesPara - NumBytesAddr;
    //
    // Calculate the transfer mode.
    //
    IsDTR = 0;
    if ( (Flags & FS_RAMDISK_HW_FLAG_DTR_ADDR) != 0u)

```

```

    || ((Flags & FS_RAMDISK_HW_FLAG_DTR_DATA) != 0u) {
        IsDTR = 1;
    }
    //
    // Encode the mode and dummy bytes.
    //
    NumDummyCycles = 0;
    if (NumBytesAlt != 0) {
        NumBytes = NumBytesAlt;
        //
        // Check if a mode byte has to be sent and if yes encode its value.
        //
        if ((Flags & FS_RAMDISK_HW_FLAG_MODE_8BIT) != 0u) {
            NumBytes = NumBytesAlt - 1u;
            NumBytesAlt = 1;
        }
        // We never send more than one mode byte.
        if (pPara != NULL) {
            AltReg = (U32)*pPara;
        } else {
            AltReg = 0xFFuL;
        }
    } else {
        NumBytesAlt = 0;
    }
    if (NumBytes != 0u) {
        //
        // The remaining alternate bytes are not sent. Instead, we generate dummy cycles.
        //
        NumDummyCycles = _CalcNumCycles(FS_BUSWIDTH_GET_ADDR(BusWidth), NumBytes, IsDTR);
    }
}
//
// It seems that QUADSPI is driving the data lines one half of the clock
// cycle longer than required. This can cause that a wrong value is
// sampled immediately after a data line is switched from output to input.
// For this reason we configure QUADSPI to sample the data later than default.
//
if ((IsDTR == 0) && (NumBytesAlt != 0) && (NumDummyCycles == 0) ) {
    QUADSPI_CR |= 1uL << CR_SSHIFT_BIT;
}
//
// Calculate the number of data lines to be used for the transfer.
//
CmdMode = _GetMode(FS_BUSWIDTH_GET_CMD(BusWidth), NumBytesCmd);
AddrMode = _GetMode(FS_BUSWIDTH_GET_ADDR(BusWidth), NumBytesAddr);
AltMode = _GetMode(FS_BUSWIDTH_GET_ADDR(BusWidth), NumBytesAlt);
DataMode = _GetMode(FS_BUSWIDTH_GET_DATA(BusWidth), 1);
// We always read at least one byte.
//
// Calculate the number of bytes in each command phase.
//
AddrSize = 0;
if (NumBytesAddr) {
    AddrSize = (NumBytesAddr - 1) & CCR_ADSIZE_MASK;
}
AltSize = 0;
if (NumBytesAlt) {
    AltSize = (NumBytesAlt - 1) & CCR_ABSIZE_MASK;
}
//
// Configure the operation.
//
CfgReg = 0
    | (CCR_FMODE_MMAP << CCR_FMODE_BIT)
    | (DataMode << CCR_DMODE_BIT)
    | (AddrSize << CCR_ADSIZE_BIT)
    | (AddrMode << CCR_ADMODE_BIT)
    | (AltSize << CCR_ABSIZE_BIT)
    | (AltMode << CCR_ABMODE_BIT)
    | (NumDummyCycles << CCR_DCYC_BIT)
    | (IsDTR << CCR_DDRM_BIT)
    | (CmdMode << CCR_IMODE_BIT)
    | (*pCmd << CCR_INTRUCTION_BIT)
    ;
//
// Wait until the unit is ready for the new command.

```



```

//
TimeOut = WAIT_TIMEOUT_CYCLES;
for (;;) {
    if ((QUADSPI_SR & (1uL << SR_BUSY_BIT)) == 0) {
        break;
    }
    if (--TimeOut == 0u) {
        r = 1;
    }
    // Error, QUADSPI is not ready.
    goto Done;
}
}
r = _ClearFlags();
if (r != 0) {
    goto Done;
}
// Error, could not clear status flags.
}
QUADSPI_ABR = AltReg;
QUADSPI_CCR = CfgReg;
Done:
return r;
}

#endif // FS_RAMDISK_HW_USE_MEM_MAP_MODE

/*****
 *
 *      _HW_Control
 *
 * Function description
 *      Sends a command to serial RAM device that does not transfer any data.
 *
 * Parameters
 *      Unit          Index of the hardware layer (0-based).
 *      pCmd          [IN] Code of the command to be sent. Cannot be NULL.
 *      NumBytesCmd   Number of bytes in the command code. Cannot be 0.
 *      BusWidth      Number of data lines to be used for sending the command.
 *      Flags         Options for the data exchange.
 *
 * Return value
 *      ==0          OK, command transferred successfully.
 *      !=0          An error occurred.
 */
static int _HW_Control(U8 Unit, const U8 * pCmd, unsigned NumBytesCmd, U8 BusWidth, unsigned Flags) {
    U32 CfgReg;
    U32 CmdMode;
    U32 TimeOut;
    int r;

    FS_USE_PARA(Unit);
    // This MCU has only one QSPI controller.
    FS_USE_PARA(Flags);
    FS_DEBUG_ASSERT(FS_MTYPE_DRIVER, NumBytesCmd == 1u);
    // The QSPI controller is able to handle only 1-byte commands.
    //
    // Fill local variables.
    //
    r = 0;
    CmdMode = _GetMode(BusWidth, NumBytesCmd);
    CfgReg = 0
        | (CCR_FMODE_WRITE << CCR_FMODE_BIT)
        | (CmdMode << CCR_IMODE_BIT)
        | (*pCmd << CCR_INSTRUCTION_BIT)
        ;

    //
    // Wait until the unit is ready for the new command.
    //
    TimeOut = WAIT_TIMEOUT_CYCLES;
    for (;;) {
        if ((QUADSPI_SR & (1uL << SR_BUSY_BIT)) == 0) {
            break;
        }
        if (--TimeOut == 0u) {
            r = 1; // Error, QUADSPI is not ready.
            goto Done;
        }
    }
}

```

```

}
//
// Execute the command.
//
r = _ClearFlags();
if (r != 0) {
    goto Done;
// Error, could not clear status flags.
}
QUADSPI_DLR = 0;
QUADSPI_ABR = 0;
QUADSPI_CCR = CfgReg;
//
// Wait until the command has been completed.
//
Timeout = WAIT_TIMEOUT_CYCLES;
for (;;) {
    if ((QUADSPI_SR & (1uL << SR_BUSY_BIT)) == 0) {
        break;
    }
    if (--Timeout == 0u) {
        r = 1; // Error, QUADSPI is not ready.
        break;
    }
}
Done:
    return r;
}

/*****
*
*     _HW_Read
*
* Function description
*     Transfers data from serial RAM device to MCU.
*
* Parameters
*     Unit           Index of the hardware layer (0-based).
*     pCmd           [IN] Code of the command to be sent. Cannot be NULL.
*     NumBytesCmd    Number of bytes in the command code. Cannot be 0.
*     pPara          [IN] Command parameters (address and dummy bytes). Can be NULL.
*     NumBytesPara   Total number of address and dummy bytes to be sent. Can be 0.
*     NumBytesAddr   Number of address bytes to be send. Can be 0.
*     pData          [OUT] Data read from the serial RAM device. Can be NULL.
*     NumBytesData   Number of bytes to read from the serial RAM device. Can be 0.
*     BusWidth       Number of data lines to be used for the data transfer.
*     Flags          Options for the data exchange.
*
* Return value
*     ==0           OK, data transferred successfully.
*     !=0           An error occurred.
*/
static int _HW_Read(U8 Unit, const U8 * pCmd, unsigned NumBytesCmd, const U8 * pPara, unsigned NumBytesPara,
    unsigned NumBytesAddr, U8 * pData, unsigned NumBytesData, U16 BusWidth, unsigned Flags) {
    U32 AddrReg;
    U32 AltReg;
    U32 CfgReg;
    U32 DataMode;
    U32 AddrMode;
    U32 AltMode;
    U32 CmdMode;
    U32 DataReg;
    U32 AltSize;
    U32 AddrSize;
    U32 NumBytesAvail;
    U32 NumBytes;
    U32 NumBytesAlt;
    U32 IsDTR;
    U32 NumDummyCycles;
    U32 Timeout;
    int r;

    FS_USE_PARA(Unit);
    // This MCU has only one QSPI controller.

```

```

FS_DEBUG_ASSERT(FS_MTYPE_DRIVER, NumBytesCmd == 1u);
// The QSPI controller is able to handle only 1-byte commands.
//
// Fill local variables.
//
r          = 0;
AddrReg    = 0;
AltReg     = 0;
NumBytesAlt = NumBytesPara - NumBytesAddr;
//
// Calculate the transfer mode.
//
IsDTR = 0;
if ( ((Flags & FS_RAMDISK_HW_FLAG_DTR_ADDR) != 0u)
     || ((Flags & FS_RAMDISK_HW_FLAG_DTR_DATA) != 0u) ) {
    IsDTR = 1;
}
//
// Encode the address.
//
if (NumBytesAddr) {
    NumBytes = NumBytesAddr;
    do {
        AddrReg <<= 8;
        AddrReg |= (U32)(*pPara++);
    } while (--NumBytes);
}
//
// Encode the mode and dummy bytes.
//
NumDummyCycles = 0;
if (NumBytesAlt != 0) {
    NumBytes = NumBytesAlt;
    //
    // Check if a mode byte has to be sent and if yes encode its value.
    //
    if ((Flags & FS_RAMDISK_HW_FLAG_MODE_8BIT) != 0u) {
        NumBytes = NumBytesAlt - 1u;
        NumBytesAlt = 1;
    }
    // We never send more than one mode byte.
    if (pPara != NULL) {
        AltReg = (U32)*pPara;
    } else {
        AltReg = 0xFFuL;
    }
} else {
    NumBytesAlt = 0;
}
if (NumBytes != 0u) {
    //
    // The remaining alternate bytes are not sent. Instead, we generate dummy cycles.
    //
    NumDummyCycles = _CalcNumCycles(FS_BUSWIDTH_GET_ADDR(BusWidth), NumBytes, IsDTR);
}
}
//
// Calculate the number of data lines to be used for the transfer.
//
CmdMode = _GetMode(FS_BUSWIDTH_GET_CMD(BusWidth), NumBytesCmd);
AddrMode = _GetMode(FS_BUSWIDTH_GET_ADDR(BusWidth), NumBytesAddr);
AltMode = _GetMode(FS_BUSWIDTH_GET_ADDR(BusWidth), NumBytesAlt);
DataMode = _GetMode(FS_BUSWIDTH_GET_DATA(BusWidth), NumBytesData);
//
// Calculate the number of bytes in each command phase.
//
AddrSize = 0;
if (NumBytesAddr) {
    AddrSize = (NumBytesAddr - 1) & CCR_ADSIZE_MASK;
}
AltSize = 0;
if (NumBytesAlt) {
    AltSize = (NumBytesAlt - 1) & CCR_ABSIZE_MASK;
}
//
// Configure the operation.
//

```

```

CfgReg = 0
    | (CCR_FMODE_READ << CCR_FMODE_BIT)
    | (DataMode << CCR_DMODE_BIT)
    | (AltSize << CCR_ABSIZE_BIT)
    | (AltMode << CCR_ABMODE_BIT)
    | (AddrSize << CCR_ADSIZE_BIT)
    | (AddrMode << CCR_ADMODE_BIT)
    | (NumDummyCycles << CCR_DCYC_BIT)
    | (IsDTR << CCR_DDRM_BIT)
    | (CmdMode << CCR_IMODE_BIT)
    | (*pCmd << CCR_INSTRUCTION_BIT)
;

//
// Wait until the unit is ready for the new command.
//
TimeOut = WAIT_TIMEOUT_CYCLES;
for (;;) {
    if ((QUADSPI_SR & (1uL << SR_BUSY_BIT)) == 0) {
        break;
    }
    if (--TimeOut == 0u) {
        r = 1; // Error, QUADSPI is not ready.
        goto Done;
    }
}
//
// It seems that QUADSPI is driving the data lines one half of the clock
// cycle longer than required. This can cause that a wrong value is
// sampled immediately after a data line is switched from output to input.
// For this reason we configure QUADSPI to sample the data later than default.
//
if ((IsDTR == 0) && (NumBytesAlt != 0) && (NumDummyCycles == 0) ) {
    QUADSPI_CR |= 1uL << CR_SSHIFT_BIT;
}
//
// Execute the command.
//
r = _ClearFlags();
if (r != 0) {
    goto Done; // Error, could not clear status flags.
}
if (NumBytesData != 0) {
    QUADSPI_DLR = NumBytesData - 1; // 0 means "read 1 byte".
}
QUADSPI_ABR = AltReg;
QUADSPI_CCR = CfgReg;
if (NumBytesAddr != 0) {
    QUADSPI_AR = AddrReg;
}
//
// Read data from RAM device.
//
if (NumBytesData != 0) {
    do {
        //
        // Wait for the data to be received.
        //
        TimeOut = WAIT_TIMEOUT_CYCLES;
        for (;;) {
            NumBytesAvail = (QUADSPI_SR >> SR_FLEVEL_BIT) & SR_FLEVEL_MASK;
            if ((NumBytesAvail >= 4) || (NumBytesAvail >= NumBytesData)) {
                break;
            }
        }
        if (--TimeOut == 0u) {
            r = 1; // Error, no data received.
            goto Done;
        }
    }
}
//
// Read data and store it to destination buffer.
//
if (NumBytesData < 4) {
    //
    // Read single bytes.
    //
    do {

```

```

        *pData++ = QUADSPI_DR_BYTE;
    } while (--NumBytesData != 0);
} else {
    //
    // Read 4 bytes at a time.
    //
    DataReg = QUADSPI_DR;
    *pData++ = (U8)DataReg;
    *pData++ = (U8)(DataReg >> 8);
    *pData++ = (U8)(DataReg >> 16);
    *pData++ = (U8)(DataReg >> 24);
    NumBytesData -= 4;
}
} while (NumBytesData != 0);
}
//
// Wait until the data transfer has been completed.
//
TimeOut = WAIT_TIMEOUT_CYCLES;
for (;;) {
    if (QUADSPI_SR & (1uL << SR_TCF_BIT)) {
        break;
    }
    if (--TimeOut == 0u) {
        r = 1; // Error, transaction not completed.
        break;
    }
}
}
Done:
//
// Restore the default sampling mode.
//
QUADSPI_CR &= ~(1uL << CR_SSHIFT_BIT);
return r;
}

/*****
*
*     _HW_Write
*
* Function description
*     Transfers data from MCU to serial RAM device.
*
* Parameters
*     Unit           Index of the hardware layer (0-based).
*     pCmd           [IN] Code of the command to be sent. Cannot be NULL.
*     NumBytesCmd    Number of bytes in the command code. Cannot be 0.
*     pPara         [IN] Command parameters (address and dummy bytes). Can be NULL.
*     NumBytesPara   Total number of address and dummy bytes to be sent. Can be 0.
*     NumBytesAddr   Number of address bytes to be send. Can be 0.
*     pData         [IN] Data to be sent to the serial RAM device. Can be NULL.
*     NumBytesData   Number of bytes to be written the serial RAM device. Can be 0.
*     BusWidth       Number of data lines to be used for the data transfer.
*     Flags          Options for the data exchange.
*
* Return value
*     ==0           OK, data transferred successfully.
*     !=0           An error occurred.
*/
static int _HW_Write(U8 Unit, const U8 * pCmd, unsigned NumBytesCmd, const U8 * pPara, unsigned NumBytesPara,
    unsigned NumBytesAddr, const U8 * pData, unsigned NumBytesData, U16 BusWidth, unsigned Flags) {
    U32 AddrReg;
    U32 AltReg;
    U32 CfgReg;
    U32 DataMode;
    U32 AddrMode;
    U32 AltMode;
    U32 CmdMode;
    U32 DataReg;
    U32 AddrSize;
    U32 AltSize;
    U32 NumBytes;
    U32 NumBytesAlt;
    U32 NumBytesFree;
    U32 IsDTR;

```

```

U32 TimeOut;
int r;

FS_USE_PARA(Unit);
// This MCU has only one QSPI controller.
FS_DEBUG_ASSERT(FS_MTYPE_DRIVER, NumBytesCmd == 1u);
// The QSPI controller is able to handle only 1-byte commands.
//
// Fill local variables.
//
r          = 0;
AddrReg    = 0;
AltReg     = 0;
NumBytesAlt = NumBytesPara - NumBytesAddr;
//
// Calculate the transfer mode.
//
IsDTR = 0;
if ( ((Flags & FS_RAMDISK_HW_FLAG_DTR_ADDR) != 0u)
    || ((Flags & FS_RAMDISK_HW_FLAG_DTR_DATA) != 0u) ) {
    IsDTR = 1;
}
//
// Encode the address.
//
if (NumBytesAddr) {
    NumBytes = NumBytesAddr;
    do {
        AddrReg <<= 8;
        AddrReg |= (U32)(*pPara++);
    } while (--NumBytes);
}
//
// Encode additional information.
//
if (NumBytesPara > NumBytesAddr) {
    NumBytes = NumBytesAlt;
    do {
        AltReg <<= 8;
        AltReg |= (U32)(*pPara++);
    } while (--NumBytes);
}
//
// Calculate the number of data lines to be used for the transfer.
//
CmdMode    = _GetMode(FS_BUSWIDTH_GET_CMD(BusWidth), NumBytesCmd);
AddrMode    = _GetMode(FS_BUSWIDTH_GET_ADDR(BusWidth), NumBytesAddr);
AltMode     = _GetMode(FS_BUSWIDTH_GET_ADDR(BusWidth), NumBytesAlt);
DataMode    = _GetMode(FS_BUSWIDTH_GET_DATA(BusWidth), NumBytesData);
//
// Calculate the number of bytes in each command phase.
//
AddrSize = 0;
if (NumBytesAddr) {
    AddrSize = NumBytesAddr - 1;
}
AltSize = 0;
if (NumBytesAlt) {
    AltSize = NumBytesAlt - 1;
}
//
// Configure the operation.
//
CfgReg = 0
    | (CCR_FMODE_WRITE << CCR_FMODE_BIT)
    | (DataMode << CCR_DMODE_BIT)
    | (AltSize << CCR_ABSIZE_BIT)
    | (AltMode << CCR_ABMODE_BIT)
    | (AddrSize << CCR_AD_SIZE_BIT)
    | (AddrMode << CCR_ADMODE_BIT)
    | (IsDTR << CCR_DDRM_BIT)
    | (CmdMode << CCR_IMODE_BIT)
    | (*pCmd << CCR_INSTRUCTION_BIT)
    ;
//
// Wait until the unit is ready for the new command.

```

```

//
TimeOut = WAIT_TIMEOUT_CYCLES;
for (;;) {
    if ((QUADSPI_SR & (1uL << SR_BUSY_BIT)) == 0) {
        break;
    }
    if (--TimeOut == 0u) {
        r = 1; // Error, QUADSPI is not ready.
        goto Done;
    }
}
//
// Execute the command.
//
r = _ClearFlags();
if (r != 0) {
    goto Done; // Error, could not clear status flags.
}
if (NumBytesData != 0) {
    QUADSPI_DLR = NumBytesData - 1; // 0 means "read 1 byte".
}
QUADSPI_ABR = AltReg;
QUADSPI_CCR = CfgReg;
if (NumBytesAddr != 0) {
    QUADSPI_AR = AddrReg;
}
//
// Write data to RAM device.
//
if (NumBytesData != 0) {
    do {
        //
        // Wait for free space in FIFO.
        //
        TimeOut = WAIT_TIMEOUT_CYCLES;
        for (;;) {
            NumBytesFree = (QUADSPI_SR >> SR_FLEVEL_BIT) & SR_FLEVEL_MASK;
            NumBytesFree = NUM_BYTES_FIFO - NumBytesFree;
            if ((NumBytesFree >= 4) || (NumBytesFree >= NumBytesData)) {
                break;
            }
            if (--TimeOut == 0u) {
                r = 1; // Error, no free space in FIFO.
                goto Done;
            }
        }
        //
        // Get the data from source buffer and write it.
        //
        if (NumBytesData < 4) {
            //
            // Write single bytes.
            //
            do {
                QUADSPI_DR_BYTE = *pData++;
            } while (--NumBytesData != 0);
        } else {
            //
            // Write 4 bytes at a time if possible.
            //
            DataReg = (U32)*pData++;
            DataReg |= (U32)*pData++ << 8;
            DataReg |= (U32)*pData++ << 16;
            DataReg |= (U32)*pData++ << 24;
            NumBytesData -= 4;
            QUADSPI_DR = DataReg;
        }
    } while (NumBytesData != 0);
}
//
// Wait until the data transfer has been completed.
//
TimeOut = WAIT_TIMEOUT_CYCLES;
for (;;) {
    if (QUADSPI_SR & (1uL << SR_TCF_BIT)) {
        break;
    }
}

```

```

    }
    if (--TimeOut == 0u) {
        r = 1; // Error, transfer not completed.
        break;
    }
}
Done:
return r;
}

/*****
 *
 *      Global data
 *
 *****/

/*****
 *
 *      FS_RAMDISK_HW_SPI_STM32H743_SEGGER_QSPI_Flash_Evaluator
 */
const FS_RAMDISK_HW_TYPE_SPI FS_RAMDISK_HW_SPI_STM32H743_SEGGER_QSPI_Flash_Evaluator = {
    _HW_Init,
    _HW_Unmap,
#ifdef FS_RAMDISK_HW_USE_MEM_MAP_MODE
    _HW_Map,
#else
    NULL,
#endif // FS_RAMDISK_HW_USE_MEM_MAP_MODE
    _HW_Control,
    _HW_Read,
    _HW_Write,
    NULL,
    NULL
};

/***** End of file *****/

```

6.3 NAND flash driver

6.3.1 General information

emFile supports the use of unmanaged NAND flash devices as data storage. Two drivers for NAND flash devices also known as flash translation layers are provided:

- *SLC1 NAND driver* - Supports SLC NAND flash devices that require 1-bit error correction. In addition, it also supports the Microchip / Atmel and Adesto DataFlash devices.
- *Universal NAND driver* - Supports all modern SLC and MLC NAND flash devices. It can make use of the hardware ECC engine integrated into NAND flash devices to correct bit errors.

6.3.1.1 Selecting the correct NAND driver

The first factor to be considered is the type of storage device used. Microchip / Atmel and Adesto DataFlash devices are currently supported only by the SLC1 NAND driver while NAND flash devices are typically supported by both NAND drivers. The bit error correction requirement of the NAND flash device is the next factor. It indicates how many bit errors the error correcting code (ECC) have to be able to detect and correct. If the NAND flash devices requires only 1-bit correction capability then the SLC1 NAND driver can be used. The SLC1 NAND driver performs the bit error detection and correction in the software. For an correction capability larger than 1 bit the Universal NAND driver has to be used instead. The Universal NAND driver is able to calculate the ECC either in the hardware using the ECC integrated into the NAND flash device or MCU or in the software using an ECC library such as SEGGER emLib-ECC (<https://www.segger.com/products/security-iot/emlib/variations/ecc/>)

You can always get in contact with us if you are not sure what type of NAND driver to choose.

6.3.1.2 Multiple driver configurations

Both NAND drivers store management information to spare area of a page. The layout and the content of this information is different for each NAND driver which means that data written using one NAND driver cannot be accessed with the other one and vice versa. For example, if an application uses the SLC1 NAND driver to store data to a NAND flash device than it cannot use the Universal NAND driver to access it. The Universal NAND driver reports in this case that the NAND flash device is not properly formatted. For applications that have to support different types of NAND flash devices that require the usage of both NAND drivers it is possible to select the correct NAND driver by checking the device id of the connected NAND flash device. The description of the `FS_NAND_PHY_ReadDeviceId()` function provides an example showing how to a NAND flash device can be identified at the configuration of the file system.

6.3.1.3 Software structure

The NAND driver is organized into different layers that contains from top to bottom:

- NAND driver layer
- *NAND physical layer*
- *NAND hardware layer*

It is possible to use the NAND driver with custom hardware. If port pins or a simple memory controller are used for accessing the flash memory, only the hardware layer needs to be ported, normally no changes to the physical layer are required. If the NAND driver should be used with a special memory controller (for example special FPGA implementations), the physical layer needs to be adapted. In this case, the hardware layer is not required, because the memory controller manages the hardware access.

6.3.1.4 Bad block management

Bad block management is supported in the driver. Blocks marked as defective are skipped and are not used for data storage. The block is recognized as defective when the first byte

in the spare area of the first or second page is different than `0xFF`. The driver marks blocks as defective in the following cases:

- when the NAND flash reports an error after a write operation.
- when the NAND flash reports an error after an erase operation.
- when an uncorrectable ECC error is detected on the data read from NAND flash.

6.3.1.5 Garbage collection

The driver performs the garbage collection automatically during the write operations. If no empty NAND blocks are available to store the data, new empty NAND blocks are created by erasing the data of the NAND blocks marked as invalid. This involves a NAND block erase operation which, depending on the characteristics of the NAND flash, can potentially take a long time to complete, and therefore reduces the write throughput. For applications which require maximum write throughput, the garbage collection can be done in the application. Typically, this operation can be performed when the file system is idle. Two API functions are provided: `FS_STORAGE_Clean()` and `FS_STORAGE_CleanOne()`. They can be called directly from the task which is performing the write or from a background task. The `FS_STORAGE_Clean()` function blocks until all the invalid NAND blocks are converted to free NAND blocks. A write operation following the call to this function runs at maximum speed. The other function, `FS_STORAGE_CleanOne()`, converts a single invalid NAND block. Depending on the number of invalid NAND blocks, several calls to this function are required to clean up the entire NAND flash.

6.3.1.6 Fail-safe operation

The NAND drivers are fail-safe which means that the drivers make only atomic operations and guarantee that the file system data is always valid. If an unexpected power loss or reset interrupts a write operation, then the old data is kept while the new corrupted data is discarded. The fail-safe operation can only be guaranteed if the NAND flash device is able to fully complete the last command it received from the MCU. The picture below is an oscilloscope capture which shows how a power down sequence should look like in order to meet the requirements needed for a fail-safe operation of a NAND driver. The labels in the picture have the following meaning:

- VCC is the main power supply voltage.
- RESET is a signal driven high by a program running on the CPU. This signal goes low when the CPU stops running indicating the point in time when the last command could have been sent to NAND flash.
- VCCmin is the minimum supply voltage required for the NAND flash to properly operate.
- Tmax is the time it takes for the longest NAND flash operation to complete which is 2 ms for the NAND flash used in the test. As it can be seen in the picture the supply voltage stays above VCCmin long enough to allow for any NAND flash command to finish.

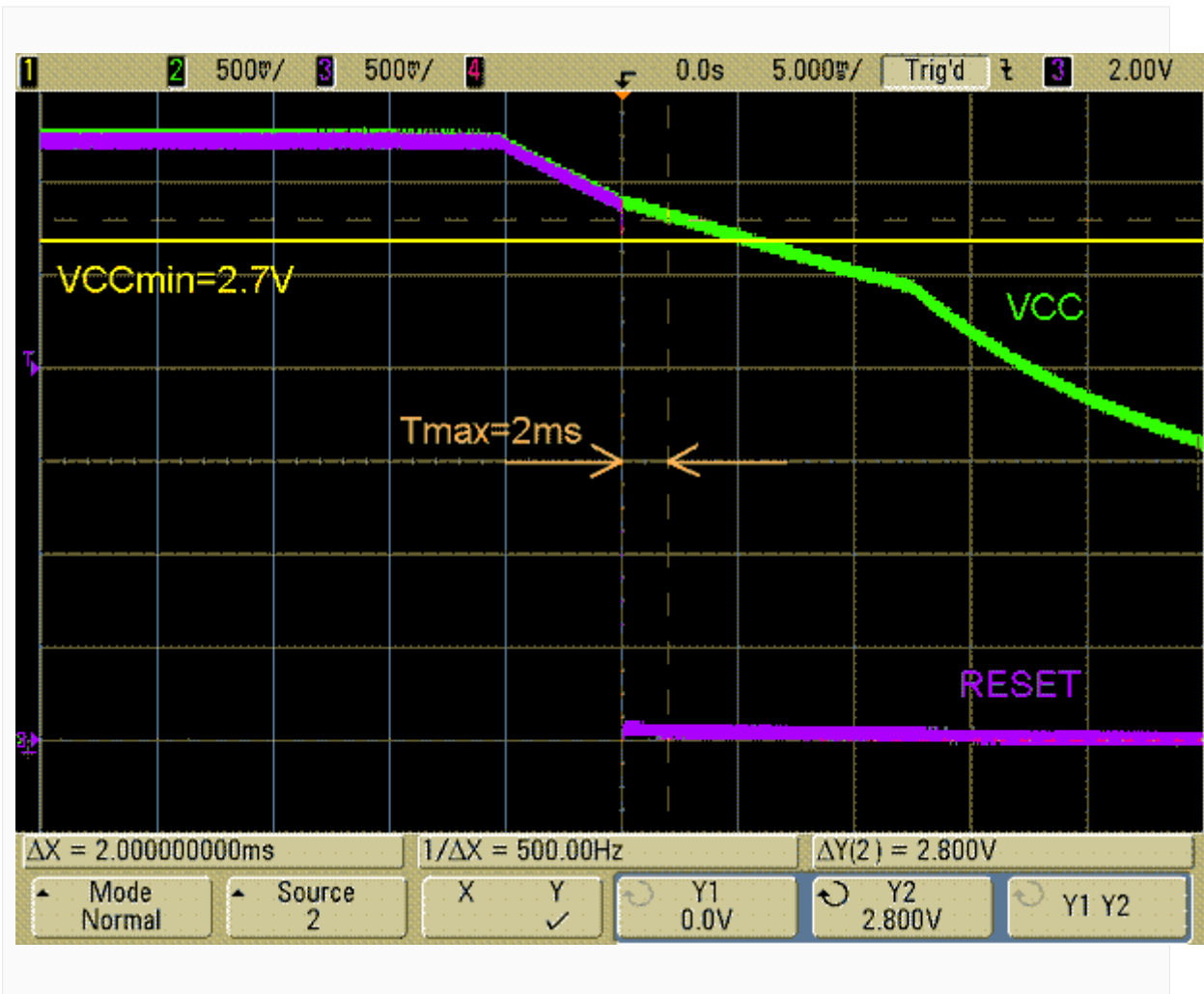

Power loss

6.3.1.7 Wear leveling

Wear leveling is supported by the NAND drivers. The procedure makes sure that the number of times a NAND block is erased remains approximately equal for all the NAND blocks. This is realized by maintaining an erase count for each NAND block. The maximum allowed erase count difference is configurable at compile time via `FS_NAND_MAX_ERASE_CNT_DIFF` as well as at runtime via `FS_NAND_SetMaxEraseCntDiff()` for the SLC1 NAND driver and `FS_NAND_UNI_SetMaxEraseCntDiff()` for the Universal NAND driver.

6.3.1.8 Read disturb errors

Read disturb errors are bit errors that occur when a large number of read operations (a few hundred thousand to one million) are performed on a NAND flash block without an erase operation taking place in between. These bit errors can be avoided by simply rewriting the sector data. This can be realized by calling in the application the `FS_STORAGE_RefreshSectors()` storage layer API function that is able to refresh multiple sectors in a single call.

6.3.1.9 Low-level format

Before using a NAND flash device for the first time, the application has to initialize it by performing a low-level format operation on it. Refer to `FS_FormatLow()` and `FS_FormatLLIfRequired()` for detailed information about this.

6.3.1.10 NAND flash organization

A NAND flash device is a serial-type memory device that uses the I/O pins for both address and data transfer as well as for command inputs. A NAND flash device consist of a number

of individual storage blocks. Every block contains a number of pages, typically 64. The pages can be written to individually, one at a time. When writing to a page, bits can only be changed from 1 to 0. Only entire blocks (all pages in the block) can be erased. Erasing means bringing all memory bits in all pages of the block to logical 1. The erase and program operations are executed automatically by the NAND flash device.

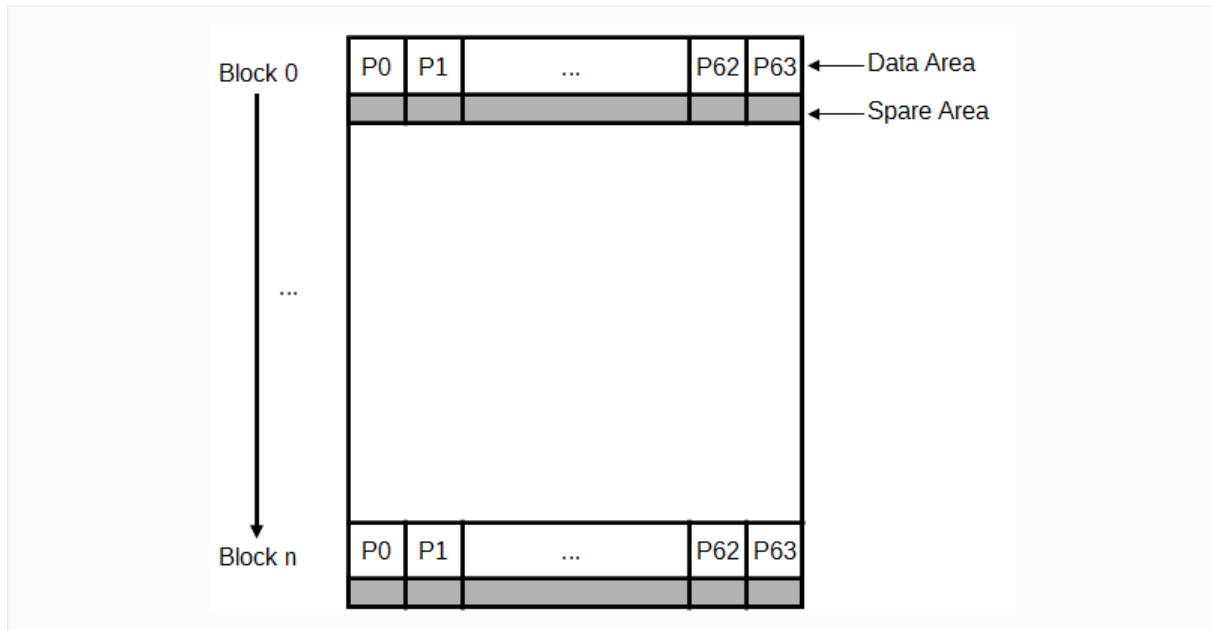

NAND organization

Small NAND flashes (up to 256 Mbytes) have a page size of 528 bytes, that is 512 bytes for storing file system data and 16 bytes, called the spare area, for storing management information (ECC, etc.).

Large NAND devices (256 Mbytes or more) have a page size of 2112 bytes with 2048 bytes used for storing file system data data and with 64 bytes of spare area.

6.3.1.11 Pin description - parallel NAND flash device

This type of devices uses 8 or 16 I/O signals to exchange the data with the MCU an additional set of signals that are used to control the data transfer.

Signal name	Description
CE	Chip Enable - The CE signal enables the device. This signal is active low. If the signal is inactive, device is in standby mode.
WE	Write Enable - The WE signal controls the transfer of data from MCU to NAND flash device. This signal is active low. Commands, address and data are latched on the rising edge of the WE pulse.
RE	Read Enable - The RE signal controls the transfer of data from NAND flash device to MCU. This signal is active low. When active the NAND flash device outputs data.
CLE	Command Latch Enable - The CLE signal controls the activating path for commands sent to NAND flash device. This signal is active high. When active, command data sent via the I/O signals is latched by the NAND flash device into the internal command register on the rising edge of the WE signal.
ALE	Address Latch Enable - The ALE signal controls the activating path for address to the internal address registers. This signal is active high. Address data is latched on the rising edge of WE with ALE high.
WP	Write Protect - The WP signal controls if data can be stored to NAND flash device. This signal is active low and is typically connected to VCC (recommended), but may also be connected to port pin.

Signal name	Description
R/B	Ready/Busy - The R/B signal indicates the status of the NAND flash device operation to MCU. When low, it indicates that a program, erase or read operation is in process. The signal returns to high when the operation is completed. It is an open drain output that should be connected to a port pin with pull-up. If available, a port pin which can trigger an interrupt can be connected to this signal.
I/O0-I/O7	Data Input/Output - The data I/O signals are used to input command, address and data, and to output data during read operations.
I/O8-I/O15	Data Input/Output - Additional data I/O signals.

6.3.1.12 Pin description - DataFlash device

DataFlash devices are commonly used when low pin count and easy data transfer are required. DataFlash devices use the following pins:

Signal name	Description
CS	Chip Select - This signal selects the DataFlash device. The device is selected, when CS pin is driven low.
SCLK	Serial Clock - The SCLK signal is used to control the flow of data to and from the DataFlash. Data is always clocked into the device on the rising edge of SCLK and clocked out of the device on the falling edge of SCLK.
SI	Serial Data In - The SI signal is used to transfer data to the DataFlash device. It is used for all data input including opcodes and address sequences.
SO	Serial Data Out - The SO signal is used to transfer data serially out of the DataFlash device.

Additionally, the host system has to comply with the following requirements:

- The data transfer width is 8 bit.
- The Chip Select (CS) signal sets the device active at low-level and inactive at high level.
- The clock signal has to be generated by the target system. The serial flash devices are always in slave mode.
- The bit order requires most significant bit (MSB) to be sent out first.

6.3.2 SLC1 NAND driver

SLC1 NAND driver is an extremely efficient and low footprint driver that can be used to access the data stored on a raw NAND flash device. The driver is designed to support one or multiple Single Level Cell (SLC) NAND flash devices that require 1-bit error correction capability. The SLC1 NAND flash driver can also be used to access the data stored on Microchip / Atmel and Adesto DataFlash devices. Different sector sizes are supported to help reduce the RAM usage of the file system.

6.3.2.1 Supported hardware

the SLC1 NAND driver supports almost all SLC NAND flash devices. This includes NAND flash devices with page sizes of 512 + 16 and 2048 + 64 bytes.

6.3.2.1.1 Tested and compatible NAND flash devices

The table below lists the NAND flash devices that have been tested or are compatible with a tested device. In addition the NAND flash driver fully supports the Dialog Semiconductor / Adesto / Atmel DataFlash devices with capacities up to 128 MBit.

Device name	Page size	Number of blocks	Storage capacity	Bus width
ATO				
AFND1G08U3	2048+64 byte	1024	128 MiB	16 bit
Dialog Semiconductor/Adesto/Atmel				
AT25PE16	512+16 byte	512	2 MiB	1 bit
AT45BR3214B	512+16 byte	1024	4 MiB	1 bit
AT45DB011B	256+8 byte	64	128 KiB	1 bit
AT45DB021B	256+8 byte	128	256 KiB	1 bit
AT45DB041B	256+8 byte	256	512 KiB	1 bit
AT45DB081B	256+8 byte	512	1 MiB	1 bit
AT45DB1282	1024+32 byte	2048	16 MiB	1 bit
AT45DB161B	512+16 byte	512	2 MiB	1 bit
AT45DB161E	512+16 byte	512	2 MiB	1 bit
AT45DB321C	512+16 byte	1024	4 MiB	1 bit
AT45DB321E	512+16 byte	1024	4 MiB	1 bit
AT45DB641E	256+8 byte	4096	8 MiB	1 bit
AT45DB642D	1024+32 byte	1024	8 MiB	1 bit
AT45DCB002	512+16 byte	512	2 MiB	1 bit
AT45DCB004	512+16 byte	1024	4 MiB	1 bit
AT45DCB008	1024+32 byte	1024	8 MiB	1 bit
Hynix				
HY27SA081G1M	512+16 byte	8192	512 MiB	8 bit
HY27SS08121M	512+16 byte	4096	512 MiB	8 bit
HY27SS08561M	512+16 byte	2048	256 MiB	8 bit
HY27UA081G1M	512+16 byte	8192	512 MiB	8 bit
HY27UF081G2A	2048+64 byte	1024	128 MiB	8 bit
HY27UF081G2M	2048+64 byte	1024	128 MiB	8 bit
HY27UF082G2M	2048+64 byte	2048	256 MiB	8 bit
HY27UF084G2M	2048+64 byte	4096	512 MiB	8 bit

Device name	Page size	Number of blocks	Storage capacity	Bus width
HY27UG084G2M	2048+64 byte	4096	512 MiB	8 bit
HY27UG084GDM	2048+64 byte	4096	512 MiB	8 bit
HY27US08121M	512+16 byte	4096	512 MiB	8 bit
HY27US08281A	512+16 byte	1024	128 MiB	8 bit
HY27US08561M	512+16 byte	2048	256 MiB	8 bit
Kioxia/Toshiba				
TC5816BFT	256+8 byte	512	2 MiB	8 bit
TC582562A	512+8 byte	2048	32 MiB	8 bit
TC58256AFT	512+8 byte	2048	32 MiB	8 bit
TC58512FT	512+8 byte	4096	64 MiB	8 bit
TC58V32AFT	512+8 byte	512	4 MiB	8 bit
TC58V64BFT	512+8 byte	1024	8 MiB	8 bit
TH58100FT	512+8 byte	8192	128 MiB	8 bit
Micron				
MT29F2G08AAB	2048+64 byte	2048	256 MiB	8 bit
MT29F2G08ABD	2048+64 byte	2048	256 MiB	8 bit
MT29F2G16AAD	2048+64 byte	2048	256 MiB	16 bit
MT29F2G16AAD	2048+64 byte	2048	256 MiB	16 bit
MT29F4G08AAA	2048+64 byte	4096	512 MiB	8 bit
MT29F4G08BAB	2048+64 byte	4096	512 MiB	8 bit
STMicroelectronics				
NAND01GR3A	512+16 byte	8192	1 GiB	8 bit
NAND01GR3B	2048+64 byte	1024	128 MiB	8 bit
NAND01GW3A	512+16 byte	8192	1 GiB	8 bit
NAND01GW3B	2048+64 byte	1024	128 MiB	8 bit
NAND02GR3B	2048+64 byte	2048	256 MiB	8 bit
NAND02GW3B	2048+64 byte	2048	256 MiB	8 bit
NAND04GW3B	2048+64 byte	4096	512 MiB	8 bit
NAND128R3A	512+16 byte	1024	128 MiB	8 bit
NAND128W3A	512+16 byte	1024	128 MiB	8 bit
NAND256R3A	512+16 byte	2048	256 MiB	8 bit
NAND256W3A	512+16 byte	2048	256 MiB	8 bit
NAND512R3A	512+16 byte	4096	512 MiB	8 bit
NAND512W3A	512+16 byte	4096	512 MiB	8 bit
Samsung				
K9F1208B0B	512+16 byte	4096	64 MiB	8 bit
K9F1208R0B	512+16 byte	4096	64 MiB	8 bit
K9F1208U0B	512+16 byte	4096	64 MiB	8 bit
K9F1G08R0A	2048+64 byte	1024	128 MiB	8 bit
K9F1G08U0A	2048+64 byte	1024	128 MiB	8 bit
K9F1G08U0C	2048+64 byte	1024	128 MiB	8 bit
K9F2808Q0B	512+16 byte	1024	16 MiB	8 bit

Device name	Page size	Number of blocks	Storage capacity	Bus width
K9F2808U0B	512+16 byte	1024	16 MiB	8 bit
K9F2G08U0M	2048+64 byte	2048	256 MiB	8 bit
K9F4G08U0A	2048+64 byte	4096	512 MiB	8 bit
K9F4G08U0M	2048+64 byte	4096	512 MiB	8 bit
K9F5608B0D	512+16 byte	2048	32 MiB	8 bit
K9F5608R0D	512+16 byte	2048	32 MiB	8 bit
K9F5608U0D	512+16 byte	2048	32 MiB	8 bit
K9F6408Q0C	512+16 byte	1024	8 MiB	8 bit
K9F6408U0C	512+16 byte	1024	8 MiB	8 bit
K9F8G08U0M	2048+128 byte	4096	1 GiB	8 bit
K9K1G08B0B	512+16 byte	8192	128 MiB	8 bit
K9K1G08R0B	512+16 byte	8192	128 MiB	8 bit
K9K1G08U0B	512+16 byte	8192	128 MiB	8 bit
K9K1G08U0M	512+16 byte	8192	128 MiB	8 bit
K9K2G08R0A	2048+64 byte	2048	256 MiB	8 bit
K9K2G08U0M	2048+64 byte	2048	256 MiB	8 bit
SkyHigh/Cypress				
S34ML01G100TFI000	2048+64 byte	1024	128 MiB	8 bit
S34ML04G100TFI000	2048+64 byte	4096	512 MiB	8 bit
S34MS02G100TFI000	2048+64 byte	2048	256 MiB	8 bit
Winbond				
W29N08GVSIAA	2048+64 byte	8192	1 GiB	8 bit

Support for devices not in this list

Most other NAND flash devices are compatible with one of the supported devices. Thus, the driver can be used with these devices or may only need a little modification, which can be easily done. Get in touch with us, if you have questions about support for devices not in this list.

Note

DataFlash devices with a page size that is a power of 2 are not supported by the SLC1 NAND driver.

6.3.2.2 Theory of operation

NAND flash devices are divided into physical blocks and physical pages. One physical block is the smallest erasable unit; one physical page is the smallest writable unit. Small block NAND flashes contain multiple pages. One block contain typically 16 / 32 / 64 pages per block. Every page has a size of 528 bytes (512 data bytes + 16 spare bytes). Large block NAND Flash devices contain blocks made up of 64 pages, each page containing 2112 bytes (2048 data bytes + 64 spare bytes). The driver uses the spare bytes for the following purposes:

1. To check if the data status byte and block status are valid. If they are valid the driver uses this sector. When the driver detects a bad sector, the whole block is marked as invalid and its content is copied to a non-defective block.

2. To store/read an ECC (Error Correcting Code) for data reliability. When reading a sector, the driver also reads the ECC stored in the spare area of the sector, calculates the ECC based on the read data and compares the ECCs. If the ECCs are not identical, the driver tries to recover the data, based on the read ECC. When writing to a page the ECC is calculated based on the data the driver has to write to the page. The calculated ECC is then stored in the spare area.

6.3.2.3 Error correction using ECC

The SLC1 NAND driver is highly speed optimized and offers a better error detection and correction than a standard memory controller ECC. The ECC is capable of single bit error correction and 2-bit random detection. When a block for which the ECC is calculated has 2 or more bit errors, the data cannot be corrected. Standard memory controllers calculate an ECC for the complete block size (512 / 2048 bytes). The ECC routines of the SLC1 NAND driver calculates the ECC for data chunks of 256 bytes (e.g. a page with 2048 bytes is divided into 8 parts of 256 bytes), therefore the probability to detect and also correct data errors is much higher. This enhancement is realized with a very good performance. The ECC computation of the SLC1 NAND driver is highly optimized, so that a performance of 18 Mbytes/second can be achieved with an ARM7 based MCU running at 48 MHz. We suggest the use of the SLC1 NAND driver without enabling the hardware ECC of the memory controller, because the performance of the driver is very high and the error correction is much better.

6.3.2.4 Partial write operations

Most NAND devices allow a write operation to change an arbitrary number of bytes starting from any byte offset inside a page. A write operation that does not change all the bytes in page is called partial write or partial programming. The driver makes extensive use of this feature to increase the write speed and to reduce the RAM usage. But there is a limitation of this method imposed by the NAND technology. The manufacturer does not guarantee the integrity of the data if a page is partially written more than a number of times without an intermediate erase operation. The maximum number of partial writes is usually four. Exceeding the maximum number of partial writes does not lead automatically to the corruption of data in that page but it can increase the probability of bit errors. The driver is able to correct single bit errors using ECC. For some combinations of logical sector size and NAND page size the driver might exceed the limit for the number of partial write operations. The table below summarizes the maximum number of partial writes performed by the SLC1 NAND driver for different logical sector sizes:

NAND page size (bytes)	Logical sector size (bytes)	Maximum number of partial write operations
512	512	4
2048	2048	4
2048	1024	5
2048	512	8

6.3.2.5 Configuring the driver

This section describes how to configure the file system to make use of the SLC1 NAND driver.

6.3.2.5.1 Compile time configuration

The SLC1 NAND driver can optionally be configured at compile time. Typically, this step can be omitted because the SLC1 NAND driver provides reasonable default values that work for most of the target applications. The compile time configuration is realized via preprocessor defines that have to be added to the `FS_Conf.h` file which is the main configuration file of emFile. For detailed information about the configuration of emFile and of the configuration define types, refer to *Configuration of emFile* on page 1218. The following table lists the configuration defines supported by the SLC1 NAND driver.

Define	Default value	Type	Description
FS_NAND_ENABLE_STATS	0 or 1	B	Enables or disables the support for statistical counters.
FS_NAND_NUM_READ_RETRIES	10	N	Configures the number of retries in case of a read error.
FS_NAND_NUM_WRITE_RETRIES	10	N	Configures the number of retries in case of a write error.
FS_NAND_NUM_UNITS	4	N	Configures the maximum number of driver instances.
FS_NAND_VERIFY_ERASE	0	B	Enables or disables the verification of the erase operation.
FS_NAND_VERIFY_WRITE	0	B	Enables or disables the verification of the write operation.

6.3.2.5.1.1 FS_NAND_ENABLE_STATS

This define can be used to enable the support for statistical counters. The statistical counters provide information about the number of operations performed internally by the SLC1 NAND driver that can be useful for debugging. The statistical counters can be queried via `FS_NAND_GetStatCounters()`. By default `FS_NAND_ENABLE_STATS` is set to 1 if `FS_DEBUG_LEVEL` is set to a value greater than or equal to `FS_DEBUG_LEVEL_CHECK_ALL`.

6.3.2.5.1.2 FS_NAND_NUM_READ_RETRIES

Number of times the SLC1 NAND driver retries the operation in case of a read error (device error or uncorrectable bit error). `NumReadRetries` of `FS_NAND_STAT_COUNTERS` is incremented by 1 on each retry.

6.3.2.5.1.3 FS_NAND_NUM_WRITE_RETRIES

Number of times the SLC1 NAND driver retries the operation in case of a write error. A write error occurs when the NAND flash device is not able to write the data to memory array. This condition is typically reported via a flag in the status register of the NAND flash device that is queried by the NAND physical layer after each write operation. `NumWriteRetries` of `FS_NAND_STAT_COUNTERS` is incremented by 1 on each retry.

6.3.2.5.1.4 FS_NAND_NUM_UNITS

This define specifies the maximum number of driver instances of the SLC1 NAND driver the application is allowed create. Four bytes of static RAM are reserved for each instance. If the maximum number of driver instances is smaller than the default then `FS_NAND_NUM_UNITS` can be set to the to that value in order to reduce the RAM usage.

6.3.2.5.1.5 FS_NAND_VERIFY_ERASE

This define can be used to activate the erase verification of the SLC1 NOR driver. The erase verification is performed after each erase operation by reading back the entire data of the erase block and by comparing each byte in the block with `0xFF`. An error is reported if a difference is detected. This feature has to be enabled at runtime by calling `FS_NAND_SetEraseVerification()`.

Note

Activating the erase verification may negatively affect the write performance.

6.3.2.5.1.6 FS_NAND_VERIFY_WRITE

This define can be used to activate the write verification of the SLC1 NAND driver. The write verification is performed after each write operation by reading back the modified data and

by comparing it with the data requested to be written. An error is reported if a difference is detected. This feature has to be enabled at runtime by calling `FS_NAND_SetWriteVerification()`.

Note

Activating the write verification may negatively affect the write performance.

6.3.2.5.2 Runtime configuration

The driver must be added to the file system by calling `FS_AddDevice()` with the driver identifier set to the address of `FS_NAND_Driver`. This function call together with other function calls that configure the driver operation have to be added to `FS_X_AddDevices()` as demonstrated in the following example.

Example

```
#include <FS.h>
#include "FS_NAND_HW_Template.h"

#define ALLOC_SIZE      0x9000          // Memory pool for the file system in bytes

static U32 _aMemBlock[ALLOC_SIZE / 4]; // Memory pool used for semi-dynamic allocation.

void FS_X_AddDevices(void) {
    FS_AssignMemory(&_aMemBlock[0], sizeof(_aMemBlock));
    //
    // Add the driver to file system.
    //
    FS_AddDevice(&FS_NAND_Driver);
    //
    // Set the physical interface of the NAND flash.
    //
    FS_NAND_SetPhyType(0, &FS_NAND_PHY_x8);
    //
    // Skip 2 blocks (256 Kbytes in case of 2K device)
    // The size of the configured area is 128 blocks.
    // For 2K devices, this means 2 Kbytes * 64 * 128 = 16 Mbytes
    //
    FS_NAND_SetBlockRange(0, 2, 128);
    //
    // Configure the HW access routines.
    //
    FS_NAND_x8_SetHWType(0, &FS_NAND_HW_Template);
#ifdef FS_SUPPORT_FILE_BUFFER
    //
    // Enable the file buffer to increase the performance
    // when reading/writing a small number of bytes.
    //
    FS_ConfigFileBufferDefault(512, FS_FILE_BUFFER_WRITE);
#endif // FS_SUPPORT_FILE_BUFFER
}
```

The API functions listed in the next table can be used by the application to configure the behavior of the SLC1 NAND driver. The application can call them only at the file system initialization in `FS_X_AddDevices()`.

Function	Description
<code>FS_NAND_SetBlockRange()</code>	Specifies which NAND flash blocks can be used as data storage.
<code>FS_NAND_SetCleanThreshold()</code>	Specifies the minimum number of sectors that the driver should keep available for fast write operations.
<code>FS_NAND_SetEraseVerification()</code>	Enables or disables the checking of the block erase operation.

Function	Description
<code>FS_NAND_SetMaxEraseCntDiff()</code>	Configures the threshold of the wear leveling procedure.
<code>FS_NAND_SetNumWorkBlocks()</code>	Sets number of work blocks the SLC1 NAND driver uses for write operations.
<code>FS_NAND_SetOnFatalErrorCallback()</code>	Registers a function to be called by the driver when a fatal error occurs.
<code>FS_NAND_SetPhyType()</code>	Configures NAND flash access functions.
<code>FS_NAND_SetWriteVerification()</code>	Enables or disables the checking of each page write operation.

6.3.2.5.2.1 FS_NAND_SetBlockRange()

Description

Specifies which NAND flash blocks can be used as data storage.

Prototype

```
void FS_NAND_SetBlockRange(U8 Unit,
                          U16 FirstBlock,
                          U16 MaxNumBlocks);
```

Parameters

Parameter	Description
<code>Unit</code>	Index of the driver instance (0-based).
<code>FirstBlock</code>	Index of the first NAND flash block to be used as storage (0-based).
<code>MaxNumBlocks</code>	Maximum number of NAND flash blocks to be used as storage.

Additional information

This function is optional. By default, the SLC1 NAND driver uses all blocks of the NAND flash as data storage. `FS_NAND_SetBlockRange()` is useful when a part of the NAND flash has to be used for another purpose, for example to store the application program used by a boot loader, and therefore it cannot be managed by the SLC1 NAND driver. Limiting the number of blocks used by the SLC1 NAND driver can also help reduce the RAM usage.

`FirstBlock` is the index of the first physical NAND block where 0 is the index of the first block of the NAND flash device. `MaxNumBlocks` can be larger than the actual number of available NAND blocks in which case the SCL1 NAND driver silently truncates the value to reflect the actual number of NAND blocks available.

The SLC1 NAND driver uses the first NAND block in the range to store management information at low-level format. If the first NAND block happens to be marked as defective, then the next usable NAND block is used.

The read optimization of the `FS_NAND_PHY_2048x8` physical layer has to be disabled when this function is used to partition the NAND flash device in order to ensure data consistency. The read cache can be disabled at runtime using `FS_NAND_2048x8_DisableReadCache()`.

If the `FS_NAND_SetBlockRange()` is used to subdivide the same physical NAND flash device into two or more partitions then the application has to make sure that they do not overlap.

Example

Sample configuration showing how to reserve the first 16 blocks of the NAND flash.

```
#include <FS.h>

void FS_X_AddDevices(void) {
    //
    // Basic file system configuration...
    //

    //
    // Add and configure the SLC1 NAND driver.
    // Only the NAND blocks with the physical
    // indexes 16-143 are used for storage.
    //
    FS_AddDevice(&FS_NAND_Driver);
    FS_NAND_SetPhyType(0, &FS_NAND_PHY_2048x8);
    FS_NAND_SetBlockRange(0, 16, 128);

    //
    // Additional file system configuration...
}
```

```
//  
}
```

Sample configuration showing how to partition the same NAND flash device.

```
#include <FS.h>  
  
void FS_X_AddDevices(void) {  
    //  
    // Basic file system configuration...  
    //  
  
    //  
    // Add and configure the first SLC1 NAND driver.  
    // The blocks 16 blocks are used for storage,  
    // that is the NAND blocks with the physical  
    // indexes 0-15.  
    //  
    FS_AddDevice(&FS_NAND_Driver);  
    FS_NAND_SetPhyType(0, &FS_NAND_PHY_2048x8);  
    FS_NAND_SetBlockRange(0, 0, 16);  
  
    //  
    // Add and configure the second SLC1 NAND driver.  
    // The blocks 64 blocks are used for storage,  
    // that is the NAND blocks with the physical  
    // indexes 16-79.  
    //  
    FS_AddDevice(&FS_NAND_Driver);  
    FS_NAND_SetPhyType(0, &FS_NAND_PHY_2048x8);  
    FS_NAND_SetBlockRange(0, 16, 64);  
  
    //  
    // Additional file system configuration...  
    //  
}
```

6.3.2.5.2.2 FS_NAND_SetCleanThreshold()

Description

Specifies the minimum number sectors that the driver should keep available for fast write operations.

Prototype

```
int FS_NAND_SetCleanThreshold(U8      Unit,
                              unsigned NumBlocksFree,
                              unsigned NumSectorsFree);
```

Parameters

Parameter	Description
<code>Unit</code>	Index of the driver instance (0-based).
<code>NumBlocksFree</code>	Number of blocks to be kept free.
<code>NumSectorsFree</code>	Number of sectors to be kept free on each block.

Return value

= 0 OK, threshold set.
 ≠ 0 An error occurred.

Additional information

Typically, used for allowing the NAND flash to write data fast to a file on a sudden reset. At the startup, the application reserves free space, by calling the function with `NumBlocksFree` and `NumSectorsFree` set to a value different than 0. The number of free sectors depends on the number of bytes written and on how the file system is configured. When the unexpected reset occurs, the application tells the driver that it can write to the free sectors, by calling the function with `NumBlocksFree` and `NumSectorsFree` set to 0. Then, the application writes the data to file and the NAND driver stores it to the free space. Since no erase or copy operation is required, the data is written as fastest as the NAND flash device permits it.

The NAND flash device will wear out faster than normal if sectors are reserved in a work block (`NumSectors > 0`).

6.3.2.5.2.3 FS_NAND_SetEraseVerification()

Description

Enables or disables the checking of the block erase operation.

Prototype

```
void FS_NAND_SetEraseVerification(U8 Unit,
                                  U8 OnOff);
```

Parameters

Parameter	Description
<code>Unit</code>	Index of the driver instance (0-based).
<code>OnOff</code>	Specifies if the feature has to be enabled or disabled <ul style="list-style-type: none"> • =0 The erase operation is not checked. • ≠0 The erase operation is checked.

Additional information

This function is optional. The result of a block erase operation is normally checked by evaluating the error bits maintained by the NAND flash device in a internal status register. `FS_NAND_SetEraseVerification()` can be used to enable additional verification of the block erase operation that is realized by reading back the contents of the entire erased physical block and by checking that all the bytes in it are set to `0xFF`. Enabling this feature can negatively impact the write performance of SLC1 NAND driver.

The block erase verification feature is active only when the SLC1 NAND driver is compiled with the `FS_NAND_VERIFY_ERASE` configuration define is set to 1 (default is 0) or when the `FS_DEBUG_LEVEL` configuration define is set to a value greater than or equal to `FS_DEBUG_LEVEL_CHECK_ALL`.

6.3.2.5.2.4 FS_NAND_SetMaxEraseCntDiff()

Description

Configures the threshold of the wear leveling procedure.

Prototype

```
void FS_NAND_SetMaxEraseCntDiff(U8 Unit,
                                U32 EraseCntDiff);
```

Parameters

Parameter	Description
Unit	Index of the driver instance (0-based).
EraseCntDiff	Maximum allowed difference between the erase counts of any two NAND blocks.

Additional information

This function is optional. It can be used to control how the SLC1 NAND driver performs the wear leveling. The wear leveling procedure makes sure that the NAND blocks are equally erased to meet the life expectancy of the storage device by keeping track of the number of times a NAND block has been erased (erase count). The SLC1 NAND driver executes this procedure when a new empty NAND block is required for data storage. The wear leveling procedure works by first choosing the next available NAND block. Then the difference between the erase count of the chosen block and the NAND block with lowest erase count is computed. If this value is greater than `EraseCntDiff` the NAND block with the lowest erase count is freed and made available for use.

The same threshold can also be configured at compile time via the `FS_NAND_MAX_ERASE_CNT_DIFF` configuration define.

Example

```
#include <FS.h>

void FS_X_AddDevices(void) {
    //
    // Basic file system configuration...
    //

    //
    // Add and configure the SLC1 NAND driver.
    //
    FS_AddDevice(&FS_NAND_Driver);
    FS_NAND_SetPhyType(0, &FS_NAND_PHY_2048x8);
    FS_NAND_SetMaxEraseCntDiff(0, 5000);

    //
    // Additional file system configuration...
    //
}
```

6.3.2.5.2.5 FS_NAND_SetNumWorkBlocks()

Description

Sets number of work blocks the SLC1 NAND driver uses for write operations.

Prototype

```
void FS_NAND_SetNumWorkBlocks(U8 Unit,
                              U32 NumWorkBlocks);
```

Parameters

Parameter	Description
<code>Unit</code>	Index of the driver instance (0-based).
<code>NumWorkBlocks</code>	Number of work blocks.

Additional information

This function is optional. It can be used to change the default number of work blocks according to the requirements of the application. Work blocks are physical NAND blocks that the SLC1 NAND driver uses to temporarily store the data written to NAND flash device. The SLC1 NAND driver calculates at low-level format the number of work blocks based on the total number of blocks available on the NAND flash device.

By default, the NAND driver allocates 10% of the total number of NAND blocks used as storage, but no more than 10 NAND blocks. The minimum number of work blocks allocated by default depends on whether journaling is used or not. If the journal is active 4 work blocks are allocated, else SLC1 NAND driver allocates 3 work blocks. The currently allocated number of work blocks can be checked via `FS_NAND_GetDiskInfo()`. The value is returned in the `NumWorkBlocks` member of the `FS_NAND_DISK_INFO` structure.

Increasing the number of work blocks can help increase the write performance of the SLC1 NAND driver. At the same time the RAM usage of the SLC1 NAND driver increases since each configured work block requires a certain amount of RAM for the data management. This is a trade-off between write performance and RAM usage.

The new value take effect after the NAND flash device is low-level formatted via `FS_FormatLow()` or `FS_NAND_FormatLow()` API functions.

Example

```
#include <FS.h>

void FS_X_AddDevices(void) {
    //
    // Basic file system configuration...
    //

    //
    // Add and configure the SLC1 NAND driver.
    //
    FS_AddDevice(&FS_NAND_Driver);
    FS_NAND_SetPhyType(0, &FS_NAND_PHY_2048x8);
    FS_NAND_SetNumWorkBlocks(0, 5);

    //
    // Additional file system configuration...
    //
}
```

6.3.2.5.2.6 FS_NAND_SetOnFatalErrorCallback()

Description

Registers a function to be called by the driver when a fatal error occurs.

Prototype

```
void FS_NAND_SetOnFatalErrorCallback
    (FS_NAND_ON_FATAL_ERROR_CALLBACK * pOnFatalError);
```

Parameters

Parameter	Description
<code>pOnFatalError</code>	Pointer to callback function.

Additional information

This function is optional. If no callback function is registered the SLC1 NAND driver behaves as if the callback function returned 1. This means that the NAND flash remains writable after the occurrence of the fatal error. emFile versions previous to 4.04b behave differently and mark the NAND flash as read-only in this case. For additional information refer to `FS_NAND_ON_FATAL_ERROR_CALLBACK`.

Typically, the SLC1 NAND driver reports a fatal error when an uncorrectable bit error occurs, that is when the ECC is not able to correct the bit errors. A fatal error can also be reported on other events such the failure to erase a NAND block. The type of error is indicated to the callback function via the `ErrorType` member of the `FS_NAND_FATAL_ERROR_INFO` structure.

All instances of the SLC1 NAND driver share the same callback function. The `Unit` member of the `FS_NAND_FATAL_ERROR_INFO` structure passed as parameter to the `pOnFatalError` callback function can be used to determine which driver instance triggered the fatal error.

6.3.2.5.2.7 FS_NAND_SetPhyType()

Description

Configures NAND flash access functions.

Prototype

```
void FS_NAND_SetPhyType(      U8          Unit,
                             const FS_NAND_PHY_TYPE * pPhyType);
```

Parameters

Parameter	Description
<code>Unit</code>	Index of the driver instance (0-based)
<code>pPhyType</code>	in Physical layer to be used to access the NAND flash device.

Additional information

This function is mandatory and it has to be called in `FS_X_AddDevices()` once for each instance of the SLC1 NAND driver. The driver instance is identified by the `Unit` parameter. First SLC1 NAND driver instance added to the file system via a `FS_AddDevice(&FS_NAND_Driver)` call has the unit number 0, the SLC1 NAND driver added by a second call to `FS_AddDevice()` has the unit number 1 and so on.

6.3.2.5.2.8 FS_NAND_SetWriteVerification()

Description

Enables or disables the checking of each page write operation.

Prototype

```
void FS_NAND_SetWriteVerification(U8 Unit,
                                U8 OnOff);
```

Parameters

Parameter	Description
<code>Unit</code>	Index of the driver instance (0-based).
<code>OnOff</code>	Specifies if the feature has to be enabled or disabled <ul style="list-style-type: none"> • =0 The write operation is not checked. • ≠0 The write operation is checked.

Additional information

This function is optional. The result of a page write operation is normally checked by evaluating the error bits maintained by the NAND flash device in a internal status register. `FS_NAND_SetWriteVerification()` can be used to enable additional verification of the page write operation that is realized by reading back the contents of the written page and by checking that all the bytes are matching the data requested to be written. Enabling this feature can negatively impact the write performance of SLC1 NAND driver.

The page write verification feature is active only when the SLC1 NAND driver is compiled with the `FS_NAND_VERIFY_WRITE` configuration define is set to 1 (default is 0) or when the `FS_DEBUG_LEVEL` configuration define is set to a value greater than or equal to `FS_DEBUG_LEVEL_CHECK_ALL`.

6.3.2.5.2.9 FS_NAND_ON_FATAL_ERROR_CALLBACK

Description

The type of the callback function invoked by the NAND driver when a fatal error occurs.

Type definition

```
typedef int FS_NAND_ON_FATAL_ERROR_CALLBACK(FS_NAND_FATAL_ERROR_INFO * pFatalErrorInfo);
```

Parameters

Parameter	Description
<code>pFatalErrorInfo</code>	Information about the fatal error.

Return value

- = 0 The NAND driver has to mark the NAND flash device as read only.
- ≠ 0 The NAND flash device has to remain writable.

Additional information

If the callback function returns a 0 the NAND driver marks the NAND flash device as read-only and it remains in this state until the NAND flash device is low-level formatted. In this state all further write operations are rejected with an error by the NAND driver.

The application is responsible to handle the fatal error by for example checking the consistency of the file system via `FS_CheckDisk()`. The callback function is not allowed to invoke any other FS API functions therefore the handling of the error has to be done after the FS API function that triggered the error returns.

Depending on the type of NAND driver used, the fatal error handler can be registered either via `FS_NAND_SetOnFatalErrorCallback()` or `FS_NAND_UNI_SetOnFatalErrorCallback()`.

6.3.2.5.2.10 FS_NAND_FATAL_ERROR_INFO

Description

Information passed to callback function when a fatal error occurs.

Type definition

```
typedef struct {  
    U8    Unit;  
    U8    ErrorType;  
    U32   ErrorSectorIndex;  
} FS_NAND_FATAL_ERROR_INFO;
```

Structure members

Member	Description
Unit	Instance of the NAND driver that generated the fatal error.
ErrorType	Type of fatal error.
ErrorSectorIndex	Index of the physical sector where the error occurred. Not applicable for all type of errors.

6.3.2.6 Additional driver functions

The following functions are optional and can be used by the application to perform operations directly on the NAND flash device.

Function	Description
<code>FS_NAND_Clean()</code>	Makes sectors available for fast write operations.
<code>FS_NAND_EraseBlock()</code>	Sets all the bytes in a NAND block to 0xFF.
<code>FS_NAND_EraseFlash()</code>	Erases the entire NAND partition.
<code>FS_NAND_FormatLow()</code>	Performs a low-level format of the NAND flash device.
<code>FS_NAND_GetBlockInfo()</code>	Returns information about a specified NAND block.
<code>FS_NAND_GetDiskInfo()</code>	Returns information about the NAND partition.
<code>FS_NAND_GetStatCounters()</code>	Returns the actual values of statistical counters.
<code>FS_NAND_IsBlockBad()</code>	Checks if a NAND block is marked as defective.
<code>FS_NAND_IsLLFormatted()</code>	Checks if the NAND flash is low-level formatted.
<code>FS_NAND_ReadPageRaw()</code>	Reads data from a page without ECC.
<code>FS_NAND_ReadPhySector()</code>	This function reads a physical sector from NAND flash.
<code>FS_NAND_ResetStatCounters()</code>	Sets the values of statistical counters to 0.
<code>FS_NAND_TestBlock()</code>	Fills all the pages in a block (including the spare area) with the specified pattern and verifies if the data was written correctly.
<code>FS_NAND_WritePage()</code>	Stores data to a page of a NAND flash with ECC.
<code>FS_NAND_WritePageRaw()</code>	Stores data to a page of a NAND flash without ECC.

6.3.2.6.1 FS_NAND_Clean()

Description

Makes sectors available for fast write operations.

Prototype

```
int FS_NAND_Clean(U8          Unit,
                 unsigned NumBlocksFree,
                 unsigned NumSectorsFree);
```

Parameters

Parameter	Description
<code>Unit</code>	Index of the driver instance (0-based).
<code>NumBlocksFree</code>	Number of blocks to be kept free.
<code>NumSectorsFree</code>	Number of sectors to be kept free on each block.

Return value

= 0 OK
 ≠ 0 An error occurred

Additional information

This function is optional. It can be used to free space on the NAND flash device for data that the application has to write as fast as possible. `FS_NAND_UNI_Clean()` performs two internal operations: (1) Converts all work blocks that have less free sectors than `NumSectorsFree` into data blocks. (2) If required, convert work blocks until at least `NumBlocksFree` are available.

6.3.2.6.2 FS_NAND_EraseBlock()

Description

Sets all the bytes in a NAND block to 0xFF.

Prototype

```
int FS_NAND_EraseBlock(U8 Unit,  
                      unsigned BlockIndex);
```

Parameters

Parameter	Description
Unit	Index of the driver instance (0-based).
BlockIndex	Index of the NAND flash block to be erased.

Return value

= 0 OK, block erased.
≠ 0 An error occurred.

Additional information

This function is optional. FS_NAND_EraseBlock() function does not check if the block is marked as defective before erasing it.

6.3.2.6.3 FS_NAND_EraseFlash()

Description

Erases the entire NAND partition.

Prototype

```
int FS_NAND_EraseFlash(U8 Unit);
```

Parameters

Parameter	Description
<code>Unit</code>	Index of the driver instance (0-based).

Return value

- ≥ 0 Number of blocks which failed to erase.
- < 0 An error occurred.

Additional information

This function is optional. After the call to `FS_NAND_EraseFlash()` all the bytes in the NAND partition are set to `0xFF`.

This function has to be used with care, since it also erases blocks marked as defective and therefore the information about the block status will be lost. `FS_NAND_EraseFlash()` can be used without this side effect on storage devices that are guaranteed to not have any bad blocks, such as DataFlash devices.

6.3.2.6.4 FS_NAND_FormatLow()

Description

Performs a low-level format of the NAND flash device.

Prototype

```
int FS_NAND_FormatLow(U8 Unit);
```

Parameters

Parameter	Description
<code>Unit</code>	Index of the driver instance (0-based).

Return value

= 0 OK, NAND flash device is low-level formatted.
≠ 0 An error occurred.

Additional information

This function is optional. It is recommended that application use `FS_FormatLow()` to initialize the NAND flash device instead of `FS_NAND_FormatLow()`.

After the low-level format operation all data that was stored on the NAND flash device is lost. A low-level format has to be performed only once before using the NAND flash device for the first time. The application can check if the NAND flash device is low-level formatted by calling `FS_IsLLFormatted()` or alternatively `FS_NAND_IsLLFormatted()`.

6.3.2.6.5 FS_NAND_GetBlockInfo()

Description

Returns information about a specified NAND block.

Prototype

```
int FS_NAND_GetBlockInfo(U8          Unit,
                        U32          PhyBlockIndex,
                        FS_NAND_BLOCK_INFO * pBlockInfo);
```

Parameters

Parameter	Description
Unit	Index of the driver instance (0-based).
PhyBlockIndex	Index of the physical block to get information about.
pBlockInfo	out Information about the NAND block.

Return value

= 0 OK, information returned.
 ≠ 0 An error occurred.

Additional information

This function is not required for the functionality of the SLC1 NAND driver and is typically not linked in in production builds.

Example

```
#include <stdio.h>
#include "FS.h"

void SampleNANDGetBlockInfo(void) {
    FS_NAND_BLOCK_INFO BlockInfo;
    char                ac[100];

    FS_X_Log("Get information about block 1 of the first SLC1 NAND driver instance\n");
    FS_NAND_GetBlockInfo(0, 1, &BlockInfo);
    SEGGER_sprintf(ac, sizeof(ac), " sType:           %s\n", BlockInfo.sType);
    FS_X_Log(ac);
    SEGGER_sprintf(ac, sizeof(ac), " EraseCnt:           0x%.8x\n", BlockInfo.EraseCnt);
    FS_X_Log(ac);
    SEGGER_sprintf(ac, sizeof(ac), " LBI:                %lu\n", BlockInfo.lbi);
    FS_X_Log(ac);
    SEGGER_sprintf(ac, sizeof(ac), " NumSectorsBlank:    %d\n", BlockInfo.NumSectorsBlank);
    FS_X_Log(ac);
    SEGGER_sprintf(ac, sizeof(ac), " NumSectorsECCCorrectable: %d\n", BlockInfo.NumSectorsECCCorrectable);
    FS_X_Log(ac);
    SEGGER_sprintf(ac, sizeof(ac), " NumSectorsErrorInECC: %d\n", BlockInfo.NumSectorsErrorInECC);
    FS_X_Log(ac);
    SEGGER_sprintf(ac, sizeof(ac), " NumSectorsECCError:  %d\n", BlockInfo.NumSectorsECCError);
    FS_X_Log(ac);
    SEGGER_sprintf(ac, sizeof(ac), " NumSectorsInvalid:  %d\n", BlockInfo.NumSectorsInvalid);
    FS_X_Log(ac);
    SEGGER_sprintf(ac, sizeof(ac), " NumSectorsValid:    %d\n", BlockInfo.NumSectorsValid);
    FS_X_Log(ac);
}
```

6.3.2.6.6 FS_NAND_GetDiskInfo()

Description

Returns information about the NAND partition.

Prototype

```
int FS_NAND_GetDiskInfo(U8          Unit,
                       FS_NAND_DISK_INFO * pDiskInfo);
```

Parameters

Parameter	Description
Unit	Index of the driver instance (0-based).
pDiskInfo	out Information about the NAND partition.

Return value

= 0 OK, information returned.
 ≠ 0 An error occurred.

Additional information

This function is not required for the functionality of the SLC1 NAND driver and is typically not linked in production builds.

Example

```
#include <stdio.h>
#include "FS.h"

void SampleNANDGetDiskInfo(void) {
    FS_NAND_DISK_INFO DiskInfo;
    char                ac[100];

    memset(&DiskInfo, 0, sizeof(DiskInfo));
    FS_X_Log("Get information about the first SLC1 NAND driver instance:\n");
    FS_NAND_GetDiskInfo(0, &DiskInfo);
    SEGGER_sprintf(ac, sizeof(ac), "  NumPhyBlocks:      %lu\n", DiskInfo.NumPhyBlocks);
    FS_X_Log(ac);
    SEGGER_sprintf(ac, sizeof(ac), "  NumLogBlocks:      %lu\n", DiskInfo.NumLogBlocks);
    FS_X_Log(ac);
    SEGGER_sprintf(ac, sizeof(ac), "  NumPagesPerBlock:  %lu\n", DiskInfo.NumPagesPerBlock);
    FS_X_Log(ac);
    SEGGER_sprintf(ac, sizeof(ac), "  NumSectorsPerBlock: %lu\n", DiskInfo.NumSectorsPerBlock);
    FS_X_Log(ac);
    SEGGER_sprintf(ac, sizeof(ac), "  BytesPerPage:      %lu\n", DiskInfo.BytesPerPage);
    FS_X_Log(ac);
    SEGGER_sprintf(ac, sizeof(ac), "  BytesPerSector:    %lu\n", DiskInfo.BytesPerSector);
    FS_X_Log(ac);
    SEGGER_sprintf(ac, sizeof(ac), "  NumUsedPhyBlocks:  %lu\n", DiskInfo.NumUsedPhyBlocks);
    FS_X_Log(ac);
    SEGGER_sprintf(ac, sizeof(ac), "  NumBadPhyBlocks:   %lu\n", DiskInfo.NumBadPhyBlocks);
    FS_X_Log(ac);
    SEGGER_sprintf(ac, sizeof(ac), "  EraseCntMin:       %lu\n", DiskInfo.EraseCntMin);
    FS_X_Log(ac);
    SEGGER_sprintf(ac, sizeof(ac), "  EraseCntMax:       %lu\n", DiskInfo.EraseCntMax);
    FS_X_Log(ac);
    SEGGER_sprintf(ac, sizeof(ac), "  EraseCntAvg:       %lu\n", DiskInfo.EraseCntAvg);
    FS_X_Log(ac);
    SEGGER_sprintf(ac, sizeof(ac), "  IsWriteProtected:  %d\n", DiskInfo.IsWriteProtected);
    FS_X_Log(ac);
    SEGGER_sprintf(ac, sizeof(ac), "  HasFatalError:     %d\n", DiskInfo.HasFatalError);
    FS_X_Log(ac);
    SEGGER_sprintf(ac, sizeof(ac), "  ErrorType:         %d\n", DiskInfo.ErrorType);
    FS_X_Log(ac);
    SEGGER_sprintf(ac, sizeof(ac), "  ErrorSectorIndex:  %lu\n", DiskInfo.ErrorSectorIndex);
    FS_X_Log(ac);
}
```

```
}
```

6.3.2.6.7 FS_NAND_GetStatCounters()

Description

Returns the actual values of statistical counters.

Prototype

```
void FS_NAND_GetStatCounters(U8 Unit,
                             FS_NAND_STAT_COUNTERS * pStat);
```

Parameters

Parameter	Description
<code>Unit</code>	Index of the driver instance (0-based)
<code>pStat</code>	<code>out</code> Values of statistical counters.

Additional information

This function is optional. It is active only when the file system is compiled with `FS_DEBUG_LEVEL` set to a value greater than or equal to `FS_DEBUG_LEVEL_CHECK_ALL` or `FS_NAND_ENABLE_STATS` set to 1.

The statistical counters can be cleared via `FS_NAND_ResetStatCounters()`.

6.3.2.6.8 FS_NAND_IsBlockBad()

Description

Checks if a NAND block is marked as defective.

Prototype

```
int FS_NAND_IsBlockBad(U8 Unit,  
                      unsigned BlockIndex);
```

Parameters

Parameter	Description
<code>Unit</code>	Index of the driver instance (0-based).
<code>BlockIndex</code>	Index of the NAND flash block to be checked.

Return value

1 Block is defective
0 Block is not defective

Additional information

This function is optional.

6.3.2.6.9 FS_NAND_IsLLFormatted()

Description

Checks if the NAND flash is low-level formatted.

Prototype

```
int FS_NAND_IsLLFormatted(U8 Unit);
```

Parameters

Parameter	Description
<code>Unit</code>	Index of the driver instance (0-based).

Return value

- = 1 NAND flash device is low-level formatted.
- = 0 NAND flash device is not low-level formatted.
- < 0 An error occurred.

Additional information

This function is optional.

6.3.2.6.10 FS_NAND_ReadPageRaw()

Description

Reads data from a page without ECC.

Prototype

```
int FS_NAND_ReadPageRaw(U8          Unit,
                        U32          PageIndex,
                        void         * pData,
                        unsigned     NumBytes);
```

Parameters

Parameter	Description
<code>Unit</code>	Index of the driver instance (0-based).
<code>PageIndex</code>	Index of the page to be read.
<code>pData</code>	<code>out</code> Data to be written.
<code>NumBytes</code>	Number of bytes to be read.

Return value

= 0 OK, data read.
 ≠ 0 An error occurred.

Additional information

This function is optional.

The data is read beginning from byte offset 0 in the page. If more data is requested than the page + spare area size, typ. 2 Kbytes + 64 bytes, the function does not modify the remaining bytes in `pData`.

6.3.2.6.11 FS_NAND_ReadPhySector()

Description

This function reads a physical sector from NAND flash.

Prototype

```
int FS_NAND_ReadPhySector(U8          Unit,
                          U32          PhySectorIndex,
                          void         * pData,
                          unsigned    * pNumBytesData,
                          void         * pSpare,
                          unsigned    * pNumBytesSpare);
```

Parameters

Parameter	Description
<code>Unit</code>	Index of the driver instance (0-based).
<code>PhySectorIndex</code>	Physical sector index.
<code>pData</code>	Pointer to a buffer to store read data.
<code>pNumBytesData</code>	in Pointer to variable storing the size of the data buffer. out The number of bytes that were stored in the data buffer.
<code>pSpare</code>	Pointer to a buffer to store read spare data.
<code>pNumBytesSpare</code>	in Pointer to variable storing the size of the spare data buffer. out The number of bytes that were stored in the spare data buffer.

Return value

- < 0 OK, all bytes are set to 0xFF in the physical sector.
- = 0 OK, no bit errors.
- = 1 OK, one bit error found and corrected.
- = 2 OK, one bit error found in the ECC.
- = 3 Error, more than 1 bit errors occurred.
- = 4 Error, could not read from NAND flash device.
- = 5 Error, internal operation.

Additional information

This function is optional.

6.3.2.6.12 FS_NAND_ResetStatCounters()

Description

Sets the values of statistical counters to 0.

Prototype

```
void FS_NAND_ResetStatCounters(U8 Unit);
```

Parameters

Parameter	Description
<code>Unit</code>	Index of the driver instance (0-based)

Additional information

This function is optional. It is active only when the file system is compiled with `FS_DEBUG_LEVEL` set to a value greater than or equal to `FS_DEBUG_LEVEL_CHECK_ALL` or `FS_NAND_ENABLE_STATS` set to 1.

The statistical counters can be queried via `FS_NAND_GetStatCounters()`.

6.3.2.6.13 FS_NAND_TestBlock()

Description

Fills all the pages in a block (including the spare area) with the specified pattern and verifies if the data was written correctly.

Prototype

```
int FS_NAND_TestBlock(U8          Unit,
                    unsigned     BlockIndex,
                    U32          Pattern,
                    FS_NAND_TEST_INFO * pInfo);
```

Parameters

Parameter	Description
Unit	Index of the driver instance (0-based).
BlockIndex	Index of the NAND block to be tested.
Pattern	Data pattern to be written during the test.
pInfo	out Optional information about the test result.

Return value

FS_NAND_TEST_RETVAL_OK	OK, no bit errors.
FS_NAND_TEST_RETVAL_CORRECTABLE_ERROR	OK, correctable bit errors found. The number of bit errors is returned in NumErrorsCorrectable of pResult.
FS_NAND_TEST_RETVAL_FATAL_ERROR	Fatal error, uncorrectable bit error found. The page index is returned in PageIndexFatalError of pResult.
FS_NAND_TEST_RETVAL_BAD_BLOCK	Bad block, skipped.
FS_NAND_TEST_RETVAL_ERASE_FAILURE	Erase operation failed. The block has been marked as defective.
FS_NAND_TEST_RETVAL_WRITE_FAILURE	Write operation failed. The block has been marked as defective.
FS_NAND_TEST_RETVAL_READ_FAILURE	Read operation failed.
FS_NAND_TEST_RETVAL_INTERNAL_ERROR	NAND flash access error.

Additional information

This function is optional. It can be used by the application to test the data reliability of a NAND block. [BlockIndex](#) is relative to the beginning of the NAND partition where the first block has the index 0.

Example

```
#include <stdio.h>
#include "FS.h"

void _SampleNANDTestBlock(void) {
    int          r;
    U32          NumPhyBlocks;
    U32          iBlock;
    FS_NAND_DISK_INFO DiskInfo;
    FS_NAND_TEST_INFO TestInfo;
    char         ac[100];

    memset(&DiskInfo, 0, sizeof(DiskInfo));
    memset(&TestInfo, 0, sizeof(TestInfo));
    FS_NAND_GetDiskInfo(0, &DiskInfo);
    NumPhyBlocks = DiskInfo.NumPhyBlocks;
    for (iBlock = 0; iBlock < NumPhyBlocks; ++iBlock) {
        r = FS_NAND_TestBlock(0, iBlock, 0xAA5500FFuL, &TestInfo);
        switch (r) {
```

```

case FS_NAND_TEST_RETVAL_OK:
    SEGGER_sprintf(ac, sizeof(ac), "Block %lu: OK.\n", iBlock);
    FS_X_Log(ac);
    break;
case FS_NAND_TEST_RETVAL_CORRECTABLE_ERROR:
    SEGGER_sprintf(ac, sizeof(ac), "Block %lu: %lu correctable error(s).\n",
        iBlock, TestInfo.BitErrorCnt);
    FS_X_Log(ac);
    break;
case FS_NAND_TEST_RETVAL_FATAL_ERROR:
    SEGGER_sprintf(ac, sizeof(ac),
        "Block %lu: %lu correctable error(s), fatal error on page %lu.\n",
        iBlock, TestInfo.BitErrorCnt, TestInfo.PageIndex);
    FS_X_Log(ac);
    break;
case FS_NAND_TEST_RETVAL_BAD_BLOCK:
    SEGGER_sprintf(ac, sizeof(ac), "Block %lu: Bad. Skipped.\n", iBlock);
    FS_X_Log(ac);
    break;
case FS_NAND_TEST_RETVAL_ERASE_FAILURE:
    SEGGER_sprintf(ac, sizeof(ac), "Block %lu: Erase failure. Marked as bad.\n", iBlock);
    FS_X_Log(ac);
    break;
case FS_NAND_TEST_RETVAL_WRITE_FAILURE:
    SEGGER_sprintf(ac, sizeof(ac), "Block %lu: Write failure on page %lu. Marked as bad.
\n",
        iBlock, TestInfo.PageIndex);
    FS_X_Log(ac);
    break;
case FS_NAND_TEST_RETVAL_READ_FAILURE:
    SEGGER_sprintf(ac, sizeof(ac), "Block %lu: Read failure on page %lu.\n",
        iBlock, TestInfo.PageIndex);
    FS_X_Log(ac);
    break;
default:
    SEGGER_sprintf(ac, sizeof(ac), "Block %lu: Internal error.\n", iBlock);
    FS_X_Log(ac);
    break;
}
}
}

```

6.3.2.6.14 FS_NAND_WritePage()

Description

Stores data to a page of a NAND flash with ECC.

Prototype

```
int FS_NAND_WritePage(    U8          Unit,
                          U32          PageIndex,
                          const void * pData,
                          unsigned     NumBytes);
```

Parameters

Parameter	Description
<code>Unit</code>	Index of the driver instance (0-based).
<code>PageIndex</code>	Index of the page to be written.
<code>pData</code>	<code>in</code> Data to be written.
<code>NumBytes</code>	Number of bytes to be written.

Return value

= 0 OK, data written.
 ≠ 0 An error occurred.

Additional information

This function is optional.

The data is written beginning with the byte offset 0 in the page. If more data is written than the size of the page, typically 2 KB + 64 bytes, the excess bytes are discarded. Data in the area reserved for ECC cannot be written using this function and it will be overwritten.

6.3.2.6.15 FS_NAND_WritePageRaw()

Description

Stores data to a page of a NAND flash without ECC.

Prototype

```
int FS_NAND_WritePageRaw(      U8      Unit,
                               U32      PageIndex,
                               const void * pData,
                               unsigned  NumBytes);
```

Parameters

Parameter	Description
<code>Unit</code>	Index of the driver instance (0-based).
<code>PageIndex</code>	Index of the page to be written.
<code>pData</code>	in Data to be written.
<code>NumBytes</code>	Number of bytes to be written.

Return value

= 0 OK, data written.
 ≠ 0 An error occurred.

Additional information

This function is optional.

The data is written beginning at the byte offset 0 in the page. If more data is written than the size of the page + spare area, typically 2 Kbytes + 64 bytes, the excess bytes are ignored.

6.3.2.6.16 FS_NAND_DISK_INFO

Description

Information about the NAND partition.

Type definition

```
typedef struct {
    U32  NumPhyBlocks;
    U32  NumLogBlocks;
    U32  NumUsedPhyBlocks;
    U32  NumBadPhyBlocks;
    U32  NumPagesPerBlock;
    U32  NumSectorsPerBlock;
    U32  BytesPerPage;
    U32  BytesPerSpareArea;
    U32  BytesPerSector;
    U32  EraseCntMin;
    U32  EraseCntMax;
    U32  EraseCntAvg;
    U8   BadBlockMarkingType;
    U8   IsWriteProtected;
    U8   HasFatalError;
    U8   ErrorType;
    U32  ErrorSectorIndex;
    U16  BlocksPerGroup;
    U32  NumWorkBlocks;
    U8   IsFormatted;
} FS_NAND_DISK_INFO;
```

Structure members

Member	Description
NumPhyBlocks	Total number of blocks in the NAND partition.
NumLogBlocks	Total number of NAND blocks that can be used to store data.
NumUsedPhyBlocks	Number of NAND blocks that store valid data.
NumBadPhyBlocks	Number of NAND blocks that are marked as defective.
NumPagesPerBlock	Number of pages in a NAND block.
NumSectorsPerBlock	Number of logical sectors stored in a NAND block.
BytesPerPage	Number of bytes in the main area of a NAND page.
BytesPerSpareArea	Number of bytes in the spare area of a NAND page.
BytesPerSector	Number of bytes is a logical sector.
EraseCntMin	Minimum value of the erase counts in the NAND partition.
EraseCntMax	Maximum value of the erase counts in the NAND partition.
EraseCntAvg	Average value of the erase counts of all the NAND blocks in the NAND partition.
BadBlockMarkingType	Type of the bad block marking.
IsWriteProtected	Set to 1 if the NAND flash device cannot be written.
HasFatalError	Set to 1 if the SLC1 NAND driver reported a fatal error.
ErrorType	Type of fatal error that has occurred.
ErrorSectorIndex	Sector index on which a fatal error occurred.
BlocksPerGroup	Number of NAND blocks in a group.
NumWorkBlocks	Number of work blocks used by the SLC1 NAND driver.
IsFormatted	Set to 1 if the NAND partition has been low-level formatted.

Additional information

Refer to *Bad block marking types* on page 579 for a list of permitted values for BadBlock-MarkingType.

6.3.2.6.17 FS_NAND_BLOCK_INFO

Description

Information about a NAND block.

Type definition

```
typedef struct {
    U32      EraseCnt;
    U32      lbi;
    U16      NumSectorsBlank;
    U16      NumSectorsValid;
    U16      NumSectorsInvalid;
    U16      NumSectorsECCError;
    U16      NumSectorsECCCorrectable;
    U16      NumSectorsErrorInECC;
    U8       IsDriverBadBlock;
    U8       BadBlockErrorType;
    U16      BadBlockErrorBRSI;
    U8       Type;
    const char * sType;
} FS_NAND_BLOCK_INFO;
```

Structure members

Member	Description
EraseCnt	Number of times the block has been erased
lbi	Logical block index assigned to queried physical block.
NumSectorsBlank	Sectors are not used yet.
NumSectorsValid	Sectors contain correct data.
NumSectorsInvalid	Sectors have been invalidated.
NumSectorsECCError	Sectors have incorrect ECC.
NumSectorsECCCorrectable	Sectors have correctable ECC error.
NumSectorsErrorInECC	Sectors have error in ECC.
IsDriverBadBlock	Set to 1 if the block has been marked as bad by the driver.
BadBlockErrorType	Type of the error that caused the block to be marked as defective.
BadBlockErrorBRSI	Block-relative sector index on which the fatal error occurred that caused the block to be marked as defective.
Type	Type of data stored in the block.
sType	Zero-terminated string holding the block type.

Additional information

Refer to *NAND block types* on page 586 for a list of permitted values for [Type](#).

[IsDriverBadBlock](#) is valid only when [Type](#) is set to `FS_NAND_BLOCK_TYPE_BAD`.

6.3.2.7 Performance and resource usage

This section provides information about the ROM and RAM usage as well as the performance of the SLC1 NAND driver. Each SLC1 NAND driver instance requires one instance of one NAND physical layer in order to operate. The resource usage of the used NAND physical layer has to be taken into account when calculating the total resource usage of the SLC1 NAND driver.

6.3.2.7.1 ROM usage

The ROM usage depends on the compiler options, the compiler version and the used CPU. The memory requirements of the SLC1 NAND driver were measured as described in the section *Test procedure* on page 1283.

Usage: 4.5 Kbytes

6.3.2.7.2 Static RAM usage

Static RAM usage refers to the amount of RAM required by the SLC1 NAND driver internally for all the driver instances. The number of bytes can be seen in the compiler list file of the `{FS_NAND_Drv.c}` file.

Usage: 32 bytes

6.3.2.7.3 Dynamic RAM usage

Dynamic RAM usage is the amount of RAM allocated by the driver at runtime. The amount RAM required depends on the runtime configuration and on the characteristics of the used NAND flash device. The approximate RAM usage of the SLC1 NAND driver can be calculated as follows:

$$\text{MemAllocated} = 160 + 2 * \text{NumberOfUsedBlocks} + 4 * \text{SectorsPerBlock} + 1.04 * \text{MaxSectorSize}$$

Parameter	Description
MemAllocated	Number of bytes allocated for one instance of the NAND driver
NumberOfUsedBlocks	Number of NAND blocks used for data storage
SectorsPerBlock	Number of logical sectors that can be stored in a NAND block
MaxSectorSize	Size of a logical sector in bytes

Example 1

2 GBit NAND flash with 2K pages, 2048 blocks used, 512-byte sectors, one NAND block consists of 64 pages, each page holds 4 sectors of 512 bytes.

```
SectorsPerBlock      = 256
NumberOfUsedBlocks   = 2048
MaxSectorSize        = 512
RAM usage             = (160 + 2 * 2048 + 4 * 256 + 1.04 * 512) bytes
RAM usage             = 5813 bytes
```

Example 2

2 GBit NAND flash with 2K pages, 2048 blocks used, 2048-byte sectors, one block consists of 64 pages, each page holds 1 sector of 2048 bytes.

```
SectorsPerBlock      = 64
NumberOfUsedBlocks   = 2048
MaxSectorSize        = 2048
RAM usage             = (160 + 2 * 2048 + 4 * 64 + 1.04 * 2048) bytes
RAM usage             = 6642 bytes
```

Example 3

512 MBit NAND flash with 512 pages, 4096 blocks used, 512-byte sectors, one block consists of 64 pages, each page holds 1 sector of 512 bytes.

```
SectorsPerBlock    = 32
NumberOfUsedBlocks = 8192
MaxSectorSize     = 512
RAM usage         = (160 + 2 * 4096 + 4 * 32 + 1.04 * 512) bytes
RAM usage         = 9013 bytes
```

6.3.2.7.4 Performance

The following performance measurements are in no way complete, but they give a good approximation of time required for common operations on various target hardware. The tests were performed as described in the section *Performance* on page 1289. All values are given in Mbytes/sec.

CPU type	NAND flash device	Write speed	Read speed
Atmel AT91SAM7S (48 MHz)	NAND flash with 512 bytes per page using port mode.	0.8	2.0
Atmel AT91SAM7S (48 MHz)	NAND flash with 2048 bytes per page and a sector size of 512 bytes using Port mode.	0.7	2.0
Atmel AT91SAM7S (48 MHz)	NAND flash with 2048 bytes per page and a sector size of 2048 bytes using the built-in NAND controller/external bus-interface.	1.3	2.3
Atmel AT91SAM7SE (48 MHz)	NAND flash with 2048 bytes per page and a sector size of 512 bytes using the built-in NAND controller/external bus-interface.	1.6	3.1
Atmel AT91SAM7SE (48 MHz)	NAND flash with 2048 bytes per page and a sector size of 2048 bytes using the built-in NAND controller/external bus-interface.	3.8	5.9
Atmel AT91SAM9261 (200 MHz)	NAND flash with 2048 bytes per page and a sector size of 512 bytes using the built-in NAND controller/external bus-interface.	2.3	6.5
Atmel AT91SAM9261 (200 MHz)	NAND flash with 2048 bytes per page and a sector size of 2048 bytes using the built-in NAND controller/external bus-interface.	5.1	9.8
Atmel AT91SAM9G45 (384 MHz)	NAND flash with 2048 bytes per page and a sector size of 2048 bytes using the built-in NAND controller/external bus-interface.	4.7	12.4
Atmel AT91SAM3U (96 MHz)	NAND flash with 2048 bytes per page and a sector size of 2048 bytes using the built-in NAND controller/external bus-interface.	5.0	5.9
Atmel AT91SAM3U (96 MHz)	NAND flash with 2048 bytes per page and a sector size of 512 bytes using the built-in NAND controller/external bus-interface.	2.3	4.7

CPU type	NAND flash device	Write speed	Read speed
Atmel AT91SAM9261 (200 MHz)	AT45DB64 DataFlash with a sector size of 1024 bytes using the SPI interface.	0.16	0.67

6.3.3 Universal NAND driver

Universal NAND driver is a very efficient device driver that was designed to support NAND flash devices that are using Single-Level Cell (SLC) as well Multi-Level Cell (MLC) technology. It requires a relatively small amount of RAM to operate and it can correct multiple bit errors by using the internal ECC of a NAND flash device or by calling ECC calculation routines provided by the application. The ECC protects the sector data and the driver management data stored in the spare area of a page which provides better data reliability. The Universal NAND driver uses a logical sector size that is equal to page size of the used NAND flash device. The NAND flash device must have a page of least 2048 bytes. Smaller logical sector sizes can be used with the help of an additional file system layer such as *Sector Size Adapter driver* on page 1165.

6.3.3.1 Supported hardware

In general, the Universal NAND driver supports almost all popular Single-Level Cell NAND flashes (SLC) with a page size larger than 2048+64 bytes. The table below shows the NAND flash devices that have been tested or are compatible with a tested device:

Device name	Page size	Number of blocks	Storage capacity	Bus width	HW ECC
ATO					
AFND1G08U3	2048+64 byte	1024	128 MiB	16 bit	No
Alliance Memory					
AS5F32G04SND	2048+128 byte	2048	256 MiB	1 bit	Yes
AS5F34G04SND	2048+128 byte	4096	512 MiB	1 bit	Yes
AS5F38G04SND	4096+256 byte	4096	1 GiB	1 bit	Yes
GigaDevice					
GD5F1GQ4UF	2048+64 byte	1024	128 MiB	1 bit	Yes
GD5F2GQ5UE	2048+128 byte	2048	256 MiB	1 bit	Yes
GD9FU1G8F2A	2048+128 byte	1024	128 MiB	8 bit	No
GD9FU4G8F2A	2048+128 byte	4096	512 MiB	8 bit	Yes
Hynix					
HY27UF081G2A	2048+64 byte	1024	128 MiB	8 bit	No
HY27UF081G2M	2048+64 byte	1024	128 MiB	8 bit	No
HY27UF082G2M	2048+64 byte	2048	256 MiB	8 bit	No
HY27UF084G2M	2048+64 byte	4096	512 MiB	8 bit	No
HY27UG084G2M	2048+64 byte	4096	512 MiB	8 bit	No
HY27UG084GDM	2048+64 byte	4096	512 MiB	8 bit	No
ISSI					
IS34ML01G081	2048+64 byte	1024	128 MiB	8 bit	No
IS34ML01G084	2048+64 byte	1024	128 MiB	8 bit	No
IS34ML02G084	2048+64 byte	2048	256 MiB	8 bit	No
IS34ML04G081	2048+64 byte	4096	512 MiB	8 bit	No
IS34ML04G084	2048+64 byte	4096	512 MiB	8 bit	No
IS35ML02G081	2048+64 byte	2048	256 MiB	8 bit	No
IS37SML01G1	2048+64 byte	1024	128 MiB	1 bit	Yes
IS38SML01G1	2048+64 byte	1024	128 MiB	1 bit	Yes
Kioxia/Toshiba					

Device name	Page size	Number of blocks	Storage capacity	Bus width	HW ECC
TC58BVG0S3HTAI0	2048+64 byte	1024	128 MiB	8 bit	Yes
TC58BVG1S3HTA00	2048+64 byte	2048	256 MiB	8 bit	Yes
TC58BYG0S3HBIAI6	2048+64 byte	1024	128 MiB	8 bit	Yes
TC58CVG0S3HRAIJ	2048+64 byte	1024	128 MiB	1 bit	Yes
TC58CVG1S3HRAIF	2048+128 byte	2048	256 MiB	1 bit	Yes
TC58CVG1S3HRAIG	2048+64 byte	2048	256 MiB	1 bit	Yes
TC58CVG1S3HRAIJ	2048+64 byte	2048	256 MiB	1 bit	Yes
TC58CVG2S0HRAIJ	4096+128 byte	2048	512 MiB	1 bit	Yes
TC58CYG0S3HRAIJ	2048+64 byte	1024	128 MiB	1 bit	Yes
TC58CYG1S3HRAIJ	2048+64 byte	2048	256 MiB	1 bit	Yes
TC58CYG2S0HRAIG	4096+128 byte	2048	512 MiB	1 bit	Yes
TC58CYG2S0HRAIJ	4096+128 byte	2048	512 MiB	1 bit	Yes
TH58BYG3S0HBIAI6	4096+128 byte	4096	1 GiB	8 bit	Yes
TH58CVG3S0HRAIJ	4096+128 byte	4096	1 GiB	1 bit	Yes
TH58CYG3S0HRAIJ	4096+128 byte	4096	1 GiB	1 bit	Yes
Macronix					
MX30LF1G18AC	2048+64 byte	1024	128 MiB	8 bit	No
MX30LF1G28AD	2048+128 byte	1024	128 MiB	8 bit	No
MX30LF1GE8AB	2048+64 byte	1024	128 MiB	8 bit	Yes
MX30LF2G28AD	2048+128 byte	2048	256 MiB	8 bit	No
MX30LF2GE8AB	2048+64 byte	2048	256 MiB	8 bit	Yes
MX30LF4G28AD	4096+256 byte	2048	512 MiB	8 bit	No
MX30LF4GE8AB	2048+64 byte	4096	512 MiB	8 bit	Yes
MX35LF1G24AD	2048+128 byte	1024	128 MiB	1 bit	No
MX35LF1GE4AB	2048+64 byte	1024	128 MiB	1 bit	Yes
MX35LF2G24AD	2048+128 byte	2048	256 MiB	1 bit	No
MX35LF2GE4AD	2048+64 byte	2048	256 MiB	1 bit	Yes
MX35LF4G24AD	4096+256 byte	2048	512 MiB	1 bit	No
MX35LF4GE4AD	4096+128 byte	2048	512 MiB	1 bit	Yes
MX60LF8G28AB	2048+112 byte	8192	1 GiB	8 bit	No
MX60LF8G28AD	4096+256 byte	4096	1 GiB	8 bit	No
Micron					
MT29F1G01AAADD	2048+64 byte	1024	128 MiB	1 bit	Yes
MT29F1G01ABAFD	2048+128 byte	1024	128 MiB	1 bit	Yes
MT29F1G01ABBFD	2048+128 byte	1024	128 MiB	1 bit	Yes
MT29F1G08ABADA	2048+64 byte	1024	128 MiB	8 bit	Yes
MT29F1G08ABAEA	2048+64 byte	1024	128 MiB	8 bit	No
MT29F1G08ABAFD	2048+128 byte	1024	128 MiB	8 bit	Yes
MT29F2G01AAAED	2048+64 byte	2048	256 MiB	1 bit	Yes
MT29F2G01ABAGD	2048+128 byte	2048	256 MiB	1 bit	Yes
MT29F2G08AAB	2048+64 byte	2048	256 MiB	8 bit	No
MT29F2G08ABABA	2048+64 byte	2048	256 MiB	8 bit	No

Device name	Page size	Number of blocks	Storage capacity	Bus width	HW ECC
MT29F2G08ABAEA	2048+64 byte	2048	256 MiB	8 bit	Yes
MT29F2G08ABAGA	2048+128 byte	2048	256 MiB	8 bit	Yes
MT29F2G08ABD	2048+64 byte	2048	256 MiB	8 bit	No
MT29F2G16AAD	2048+64 byte	2048	256 MiB	16 bit	No
MT29F2G16AAD	2048+64 byte	2048	256 MiB	16 bit	No
MT29F2G16ABAEA	2048+64 byte	2048	256 MiB	16 bit	Yes
MT29F4G01AAADD	2048+64 byte	4096	512 MiB	1 bit	Yes
MT29F4G01ABAFD	4096+256 byte	4096	512 MiB	1 bit	Yes
MT29F4G01ABBFD	4096+256 byte	2048	512 MiB	1 bit	Yes
MT29F4G08AAA	2048+64 byte	4096	512 MiB	8 bit	No
MT29F4G08ABADA	2048+64 byte	4096	512 MiB	8 bit	Yes
MT29F4G08BAB	2048+64 byte	4096	512 MiB	8 bit	No
MT29F8G01ADAFD	4096+256 byte	4096	1 GiB	1 bit	Yes
MT29F8G01ADBFD	4096+256 byte	4096	1 GiB	1 bit	Yes
MT29F8G08ABABA	4096+224 byte	2048	1 GiB	8 bit	No
MT29F8G08ABACA	4096+224 byte	4096	1 GiB	8 bit	No
STMicroelectronics					
NAND01GR3B	2048+64 byte	1024	128 MiB	8 bit	No
NAND01GW3B	2048+64 byte	1024	128 MiB	8 bit	No
NAND02GR3B	2048+64 byte	2048	256 MiB	8 bit	No
NAND02GW3B	2048+64 byte	2048	256 MiB	8 bit	No
NAND04GW3B	2048+64 byte	4096	512 MiB	8 bit	No
Samsung					
K9F1G08R0A	2048+64 byte	1024	128 MiB	8 bit	No
K9F1G08U0A	2048+64 byte	1024	128 MiB	8 bit	No
K9F1G08U0C	2048+64 byte	1024	128 MiB	8 bit	No
K9F1G08U0F	2048+64 byte	1024	128 MiB	8 bit	Yes
K9F2G08U0M	2048+64 byte	2048	256 MiB	8 bit	No
K9F4G08U0A	2048+64 byte	4096	512 MiB	8 bit	No
K9F4G08U0M	2048+64 byte	4096	512 MiB	8 bit	No
K9F8G08U0M	2048+128 byte	4096	1 GiB	8 bit	No
K9K2G08R0A	2048+64 byte	2048	256 MiB	8 bit	No
K9K2G08U0M	2048+64 byte	2048	256 MiB	8 bit	No
SkyHigh/Cypress					
S34ML01G100TFI000	2048+64 byte	1024	128 MiB	8 bit	No
S34ML04G100TFI000	2048+64 byte	4096	512 MiB	8 bit	No
S34ML04G200TFI000	2048+128 byte	4096	512 MiB	8 bit	No
S34ML04G300TFI000	2048+128 byte	4096	512 MiB	8 bit	Yes
S34ML04G300TFI100	4096+256 byte	2048	512 MiB	8 bit	Yes
S34ML08G201TFI000	2048+128 byte	8192	1 GiB	8 bit	No
S34ML08G301TFI000	2048+128 byte	8192	1 GiB	8 bit	Yes
S34ML16G202TFI200	2048+128 byte	16384	2 GiB	8 bit	No

Device name	Page size	Number of blocks	Storage capacity	Bus width	HW ECC
S34ML16G303TFI000	2048+128 byte	16384	2 GiB	8 bit	Yes
S34MS02G100TFI000	2048+64 byte	2048	256 MiB	8 bit	No
Winbond					
W25M02GVZEIT	2048+64 byte	2048	256 MiB	1 bit	Yes
W25N01GVZEIG	2048+64 byte	1024	128 MiB	1 bit	Yes
W25N02KVZEIU	2048+128 byte	2048	256 MiB	1 bit	Yes
W25N04KVZEIR	2048+128 byte	4096	512 MiB	1 bit	Yes
W25N512GVEIG	2048+64 byte	512	64 MiB	1 bit	Yes
W29N02GZSIBF	2048+64 byte	2048	256 MiB	8 bit	No
W29N08GVSI AA	2048+64 byte	8192	1 GiB	8 bit	No
XTX					
XT27G02BTSIG	2048+128 byte	0	256 MiB	8 bit	Yes

Support for devices not in the list

Most other NAND flash devices are compatible with one of the supported devices. Thus, the driver can be used with these devices or may only need a little modification, which can be easily done. Get in touch with us, if you have questions about support for devices not in this list.

6.3.3.2 Theory of operation

NAND flash devices are divided into physical blocks and physical pages. One physical block is the smallest erasable unit while one physical page is the smallest writable unit. Large block NAND Flash devices contain blocks made up of 64 pages, each page containing 2112 bytes (2048 data bytes + 64 spare bytes). The Universal NAND driver reserves the first page of a block for management data such as erase count. The Universal NAND driver uses the spare bytes for the following purposes:

1. To check if the block is valid.
If a block is valid then the driver uses it for data storage. When the driver detects an uncorrectable bit error in a page, the entire block containing that page is marked as invalid and its content is copied to a non-defective block.
2. To store/load management information.
This includes the mapping of pages to logical sectors, the number of times a block has been erased and whether a page contains valid data or not.
3. To store and load an ECC (Error Correction Code) for data reliability.
When reading a page, the driver also reads the ECC stored in the spare area of that page, calculates the ECC based on the read data and compares the ECCs. If the ECCs are not identical, the driver tries to recover the data, based on the read ECC. When writing to a page the ECC is calculated based on the data the driver has to write to the page. The calculated ECC is then stored in the spare area of that page.

6.3.3.3 Support for custom hardware

It is possible to use the Universal NAND driver with a custom hardware. If port pins or a simple memory controller are used for accessing the flash memory, only the hardware layer needs to be ported and normally no changes to the physical layer are required. If the NAND driver has to be used with a special memory controller (for example special FPGA implementations), the physical layer needs to be adapted. In this case, the hardware layer is not required, because the memory controller manages all the hardware accesses.

6.3.3.4 Partial write operations

The Universal NAND driver writes only once in any page of the NAND flash between two erase operations of the NAND block that contain that page. Therefore, the number of partial write operation is one which makes the driver compatible with any SLC and MLC NAND flash device.

6.3.3.5 High-reliability operation

The Universal NAND driver supports a feature that can be used to increase the reliability of the data stored to a NAND flash device. It works by checking the number of bit errors corrected by the ECC during each page read operation. If the number of bit errors is equal to or greater than a configured threshold the Universal NAND driver copies the contents of the NAND block containing the read page to an other location. This prevents the accumulation of bit errors that may cause ECC correction errors. An ECC correction error occurs when the number of bit errors is larger than the number of bit errors the ECC is able to correct. Typically, a correction error leads to a data loss.

This feature requires support for the `FS_NAND_PHY_TYPE_GET_ECC_RESULT` function in the NAND physical layer. By default, the feature is disabled for performance reasons and has to be explicitly enabled at compile time by setting `FS_NAND_MAX_BIT_ERROR_CNT` to a value greater than 0. This value can be modified at runtime by calling `FS_NAND_UNI_SetMaxBitErrorCnt()`.

Note

Enabling the high-reliability operation may reduce the specified lifetime of the NAND flash due to the increased number of erase cycles.

6.3.3.6 Configuring the driver

This section describes how to configure the file system to make use of the Universal NAND driver.

6.3.3.6.1 Compile time configuration

The Universal NAND driver can optionally be configured at compile time. Typically, this step can be omitted because the Universal NAND driver provides reasonable default values that work for most of the target applications. The compile time configuration is realized via preprocessor defines that have to be added to the `FS_Conf.h` file which is the main configuration file of emFile. For detailed information about the configuration of emFile and of the configuration define types, refer to *Configuration of emFile* on page 1218. The following table lists the configuration defines supported by the Universal NAND driver.

Define	Default value	Type	Description
<code>FS_NAND_ECC_HOOK_DEFAULT</code>	<code>&FS_NAND_ECC_SW_1BIT</code>	R	Configures the default ECC algorithm.
<code>FS_NAND_ENABLE_ERROR_RECOVERY</code>	0	B	Enables or disables the bit error recovery via RAID driver.
<code>FS_NAND_ENABLE_STATS</code>	0 or 1	B	Enables or disables the support for statistical counters.
<code>FS_NAND_ENABLE_STATS_SECTOR_STATUS</code>	1	B	Enables or disables the collection of statistical information about the number of valid logical sectors.
<code>FS_NAND_FILL_READ_BUFFER</code>	0 or 1	B	Enables or disables the filling of invalid sectors with predefined data.

Define	Default value	Type	Description
FS_NAND_MAX_BIT_ERROR_CNT	0	N	Configures the number of bit errors that trigger a block relocation.
FS_NAND_MAX_PAGE_SIZE	0	N	Configures the size of the main area buffer.
FS_NAND_MAX_SPARE_AREA_SIZE	0	N	Configures the size of the spare area buffer.
FS_NAND_NUM_READ_RETRIES	10	N	Configures the number of retries in case of a read error.
FS_NAND_NUM_WRITE_RETRIES	10	N	Configures the number of retries in case of a write error.
FS_NAND_NUM_UNITS	4	N	Configures the maximum number of driver instances.
FS_NAND_OPTIMIZE_SPARE_AREA_READ	0	B	Enables or disables the optimization related to reading data from the spare area.
FS_NAND_READ_BUFFER_FILL_PATTERN	0xFF	N	Configures the value to fill an invalid logical sector contents.
FS_NAND_RECLAIM_DRIVER_BAD_BLOCKS	0	B	Configures how the blocks marked as defective are handled at low-level format.
FS_NAND_STAT_MAX_BIT_ERRORS	1	N	Configures the number of statistical counters for bit errors.
FS_NAND_SUPPORT_BLOCK_GROUPING	1	B	Enables or disables the block grouping feature.
FS_NAND_VERIFY_ERASE	0	B	Enables or disables the verification of the erase operation.
FS_NAND_VERIFY_WRITE	0	B	Enables or disables the verification of the write operation.

6.3.3.6.1.1 FS_NAND_ECC_HOOK_DEFAULT

The `FS_NAND_ECC_HOOK_DEFAULT` can be used to specify default ECC calculation routines. For a file system configuration that has support for calculating the ECC in the hardware `FS_NAND_ECC_HOOK_DEFAULT` can be set to `NULL` to reduce the ROM usage. In this case it is mandatory that the application specifies at runtime a different ECC algorithm via `FS_NAND_UNI_SetECCHook()`.

6.3.3.6.1.2 FS_NAND_ENABLE_ERROR_RECOVERY

This define can be used to enable the support for error recovery in the Universal NAND driver. The error recovery is performed by getting corrected data from a redundant partition via one of the RAID components of the file system. Refer to *RAID1 driver* on page 1172 and *RAID5 driver* on page 1182 for more information about this.

6.3.3.6.1.3 FS_NAND_ENABLE_STATS

This define can be used to enable the support for statistical counters. The statistical counters provide information about the number of operations performed internally by the Universal NAND driver. This information can be useful for analyzing the performance. The statistical counters can be queried via `FS_NAND_UNI_GetStatCounters()`. By default `FS_NAND_ENABLE_STATS` is set to 1 if `FS_DEBUG_LEVEL` is set to a value greater than or equal to `FS_DEBUG_LEVEL_CHECK_ALL`.

6.3.3.6.1.4 FS_NAND_ENABLE_STATS_SECTOR_STATUS

This define can be used to configure if the Universal NAND driver has to collect information about the number of valid logical sectors. Enabling this operation may negatively affect the performance of the low-level mount operation because the the Universal NAND driver has to check the status of all logical sectors. `FS_NAND_ENABLE_STATS_SECTOR_STATUS` takes effect only if `FS_NAND_ENABLE_STATS` is set to 1.

6.3.3.6.1.5 FS_NAND_FILL_READ_BUFFER

`FS_NAND_FILL_READ_BUFFER` can be used to configure if the read buffer that receives the contents of an invalid logical sector has to be initialized with predefined data. The byte pattern that has to be used for filling the buffer contents can be specified via `FS_NAND_READ_BUFFER_FILL_PATTERN`. By default this feature is enabled only if no file system layer is used (both `FS_SUPPORT_FAT` and `FS_SUPPORT_EFS` set to 0), because the file system layer does not rely on this feature.

6.3.3.6.1.6 FS_NAND_MAX_BIT_ERROR_CNT

This define can be used to configure the monitoring of bit errors in the Universal NAND driver. The assigned value specifies the maximum number of correctable bit errors that are allowed to occur in a page before the block that contains that page is copied to another location. This is done in order to reduce the probability of a data loss as a result of an ECC correction error by keeping the number of bit errors below the bit error correction capability of the ECC algorithm. The value of `FS_NAND_MAX_BIT_ERROR_CNT` has to be smaller than or equal to the bit error correction capability that is required by the NAND flash device. The bit error monitoring is disabled if `FS_NAND_MAX_BIT_ERROR_CNT` is set to 0. The maximum number of bit errors can also be changed at runtime via `FS_NAND_UNI_SetMaxBitErrorCnt()`. Enabling this feature increases the data reliability but it may negatively affect the performance.

6.3.3.6.1.7 FS_NAND_MAX_PAGE_SIZE

`FS_NAND_MAX_PAGE_SIZE` can be used to configure the the size of the internal buffer that the Universal NAND driver uses for reading and writing the data of the main area of a page. If `FS_NAND_MAX_PAGE_SIZE` is set to 0 then the Universal NAND driver allocates a buffer with a size equal to the logical sector of the file system. In addition, the size of the buffer can be configured at runtime via `FS_NAND_UNI_SetMaxPageSize()`.

6.3.3.6.1.8 FS_NAND_MAX_SPARE_AREA_SIZE

`FS_NAND_MAX_SPARE_AREA_SIZE` can be used to configure the size of the internal buffer that the Universal NAND driver uses for reading and writing the data of the spare area of a page. If `FS_NAND_MAX_SPARE_AREA_SIZE` is set to 0 then the Universal NAND driver allocates a buffer that is 1/32 of the internal buffer allocated for the main area of a page. For example, 64 bytes are allocated if the size of the buffer used for the main area of a page is 2048 bytes. If the ratio between the size of the main and spare area of the page is different than 1/32 then `FS_NAND_MAX_SPARE_AREA_SIZE` has to be set to the number of bytes in the spare area of the NAND flash device. In addition, the size of the buffer can be configured a runtime via `FS_NAND_UNI_SetMaxSpareAreaSize()`.

6.3.3.6.1.9 FS_NAND_NUM_READ_RETRIES

`FS_NAND_NUM_READ_RETRIES` can be used to specify the number of times the Universal NAND driver retries the operation in case of a read error (device error or uncorrectable bit error). `NumReadRetries` of `FS_NAND_STAT_COUNTERS` is incremented by 1 on each retry.

6.3.3.6.1.10 FS_NAND_RECLAIM_DRIVER_BAD_BLOCKS

`FS_NAND_RECLAIM_DRIVER_BAD_BLOCKS` can be used to configure the behavior of the Universal NAND driver during the low-level format operation with regards to the NAND blocks marked as defective. If `FS_NAND_RECLAIM_DRIVER_BAD_BLOCKS` is set to 1 then the NAND blocks marked as defective by the Universal NAND driver are erased during the low-level format operation. If `FS_NAND_RECLAIM_DRIVER_BAD_BLOCKS` is set to 0 then the low-level

format operation does not erase the NAND blocks marked as defective by the Universal NAND driver. This is the default behavior. Setting `FS_NAND_RECLAIM_DRIVER_BAD_BLOCKS` to 1 is useful during the development of a NAND physical or hardware layer when NAND blocks may be marked as defective by mistake. These blocks can then be easily erased via a low-level format operation. The NAND blocks marked as defective by the manufacturer are never erased. In addition, these NAND blocks are never used for data storage.

6.3.3.6.1.11 FS_NAND_NUM_WRITE_RETRIES

`FS_NAND_NUM_WRITE_RETRIES` can be used to specify the number of times the Universal NAND driver retries the operation in case of a write error. A write error occurs when the NAND flash device is not able to write the data to memory array. This condition is typically reported via a flag in the status register of the NAND flash device that is queried by the NAND physical layer after each write operation. `NumWriteRetries` of `FS_NAND_STAT_COUNTERS` is incremented by 1 on each retry.

6.3.3.6.1.12 FS_NAND_NUM_UNITS

This define specifies the maximum number of driver instances of the Universal NAND driver the application is allowed create. Four bytes of static RAM are reserved for each instance. If the maximum number of driver instances is smaller than the default then `FS_NAND_NUM_UNITS` can be set to the to that value in order to reduce the RAM usage.

6.3.3.6.1.13 FS_NAND_OPTIMIZE_SPARE_AREA_READ

This configuration define can be used to enable an optimization that reduces the amount of data transferred by the Universal NAND driver from the spare area from a page to the MCU. With `FS_NAND_OPTIMIZE_SPARE_AREA_READ` set to 0 the entire spare area of a page is transferred to MCU each time the Universal NAND driver has to evaluate the management data of that page. If `FS_NAND_OPTIMIZE_SPARE_AREA_READ` set to 1 then only the regions of the spare area that store the management data are transferred to the MCU. This may help improve the performance when the NAND flash device is connected to the MCU via a relatively slow interface such as SPI.

6.3.3.6.1.14 FS_NAND_READ_BUFFER_FILL_PATTERN

The Universal NAND driver uses the byte value assigned to `FS_NAND_READ_BUFFER_FILL_PATTERN` to fill the read buffer that receives the contents of a logical sector that does not contain any valid data. The contents of a logical sector becomes valid when the file system layer writes any data to it. After a low-level format operation the contents of all logical sectors is invalid. The contents of a logical sector can be explicitly invalidated via a sector free operation. `FS_NAND_READ_BUFFER_FILL_PATTERN` takes effect only if `FS_NAND_FILL_READ_BUFFER` is set to 1.

6.3.3.6.1.15 FS_NAND_STAT_MAX_BIT_ERRORS

`FS_NAND_STAT_MAX_BIT_ERRORS` defines how many bit error counters the Universal NAND driver has to maintain. Each counter keeps track of the number of times a certain number of bit errors occurred at the same time during one page read operation. The first counter keeps track of the number of 1 bit errors, the second counter keeps track of the number of 2 bit errors and so on. The bit error counters can be read via `FS_NAND_UNI_GetStatCounters()`. `FS_NAND_ENABLE_STATS_SECTOR_STATUS` takes effect only if `FS_NAND_ENABLE_STATS` is set to 1.

6.3.3.6.1.16 FS_NAND_SUPPORT_BLOCK_GROUPING

`FS_NAND_SUPPORT_BLOCK_GROUPING` can be used to specify if the Universal NAND driver is able to handle of two or more adjacent NAND blocks as a single block. The number of blocks in the group has to be configured at runtime via `FS_NAND_UNI_SetNumBlocksPerGroup()`. The RAM usage of the Universal NAND driver depends on the number of NAND blocks it has to manage. Therefore, enabling the block grouping feature can help reduce the RAM usage because the the number of blocks decreases. If the block grouping feature is not required by

the application then `FS_NAND_SUPPORT_BLOCK_GROUPING` can be set to 0 in order to reduce the RAM and ROM usage of the Universal NAND driver.

6.3.3.6.1.17 FS_NAND_VERIFY_ERASE

This define can be used to activate the erase verification of the Universal NOR driver. The erase verification is performed after each erase operation by reading back the entire data of the erased block and by comparing each byte in the block with `0xFF`. An error is reported if a difference is detected. This feature has to be enabled at runtime by calling `FS_NAND_UNI_SetEraseVerification()`.

Note

Activating the erase verification may negatively affect the write performance.

6.3.3.6.1.18 FS_NAND_VERIFY_WRITE

This define can be used to activate the write verification of the Universal NAND driver. The write verification is performed after each write operation by reading back the modified data and by comparing it with the data requested to be written. An error is reported if a difference is detected. This feature has to be enabled at runtime by calling `FS_NAND_UNI_SetWriteVerification()`.

Note

Activating the write verification may negatively affect the write performance.

6.3.3.6.2 Runtime configuration

The driver must be added to the file system by calling `FS_AddDevice()` with the driver identifier set to the address of `FS_NAND_UNI_Driver`. This function call together with other function calls that configure the driver operation have to be added to `FS_X_AddDevices()` as demonstrated in the following example.

Example

```
#include "FS.h"
#include "FS_NAND_HW_Template.h"

#define ALLOC_SIZE      0x9000          // Memory pool for the file system in bytes

static U32 _aMemBlock[ALLOC_SIZE / 4]; // Memory pool used for semi-dynamic allocation.

void FS_X_AddDevices(void) {
    FS_AssignMemory(&_aMemBlock[0], sizeof(_aMemBlock));
    //
    // Add the NAND flash driver to file system. Volume name: "nand:0:".
    //
    FS_AddDevice(&FS_NAND_UNI_Driver);
    //
    // Set the physical interface of the NAND flash.
    //
    FS_NAND_UNI_SetPhyType(0, &FS_NAND_PHY_ONFI);
    //
    // Configure the driver to use the internal ECC of NAND flash for error correction.
    //
    FS_NAND_UNI_SetECCHook(0, &FS_NAND_ECC_HW_NULL);
    //
    // Configure the HW access routines.
    //
    FS_NAND_ONFI_SetHWType(0, &FS_NAND_HW_Template);
    #if FS_SUPPORT_FILE_BUFFER
    //
    // Enable the file buffer to increase the performance
    // when reading/writing a small number of bytes.
    //
    #endif
}
```



```

FS_ConfigFileBufferDefault(512, FS_FILE_BUFFER_WRITE);
#endif // FS_SUPPORT_FILE_BUFFER
}

```

The API functions listed in the next table can be used by the application to configure the behavior of the Universal NAND driver. The application can call them only at the file system initialization in `FS_X_AddDevices()`.

Function	Description
<code>FS_NAND_UNI-AllowBlankUnusedSectors()</code>	Configures if the data of unused sectors has to be initialized.
<code>FS_NAND_UNI-AllowReadErrorBadBlocks()</code>	Configures if a block is marked as defective on read fatal error.
<code>FS_NAND_UNI-SetBlockRange()</code>	Specifies which NAND blocks the driver can use to store the data.
<code>FS_NAND_UNI-SetBlockReserve()</code>	Configures the number of NAND flash blocks to be reserved as replacement for the NAND flash blocks that become defective.
<code>FS_NAND_UNI-SetCleanThreshold()</code>	Specifies the minimum number sectors that the driver should keep available for fast write operations.
<code>FS_NAND_UNI-SetDriverBadBlockReclamation()</code>	Configures if the bad blocks marked as defective by the driver have to be erased at low-level format or not.
<code>FS_NAND_UNI-SetECCHook()</code>	Configures the ECC algorithm to be used for the correction of bit errors.
<code>FS_NAND_UNI-SetEraseVerification()</code>	Enables or disables the checking of the block erase operation.
<code>FS_NAND_UNI-SetMaxBitErrorCnt()</code>	Configures the number of bit errors that trigger the relocation of the data stored in a NAND block.
<code>FS_NAND_UNI-SetMaxEraseCntDiff()</code>	Configures the threshold of the wear leveling procedure.
<code>FS_NAND_UNI-SetMaxPageSize()</code>	Configures the maximum handled page size.
<code>FS_NAND_UNI-SetMaxSpareAreaSize()</code>	Configures the maximum handled spare area size.
<code>FS_NAND_UNI-SetNumBlocksPerGroup()</code>	Specifies the number of physical NAND blocks in a virtual block.
<code>FS_NAND_UNI-SetNumWorkBlocks()</code>	Sets number of work blocks the Universal NAND driver uses for write operations.
<code>FS_NAND_UNI-SetOnFatalErrorCallback()</code>	Registers a function to be called by the driver when a fatal error occurs.
<code>FS_NAND_UNI-SetPhyType()</code>	Configures NAND flash access functions.
<code>FS_NAND_UNI-SetWriteDisturbHandling()</code>	Configures if the bit errors caused by write operations are handled or not.

Function	Description
<code>FS_NAND_UNI_SetWriteVerification()</code>	Enables or disables the checking of each page write operation.

6.3.3.6.2.1 FS_NAND_UNI_AllowBlankUnusedSectors()

Description

Configures if the data of unused sectors has to be initialized.

Prototype

```
void FS_NAND_UNI_AllowBlankUnusedSectors(U8 Unit,
                                           U8 OnOff);
```

Parameters

Parameter	Description
<code>Unit</code>	Index of driver instance (0-based).
<code>OnOff</code>	Specifies if the feature has to be enabled or disabled <ul style="list-style-type: none"> • =0 Sector data is filled with 0s. • ≠0 Sector data is not initialized (all bytes remain set to 0xFF).

Additional information

This function is optional. The default behavior of the Universal NAND driver is to fill the data of unused logical sectors with 0s. This done in order to reduce the chance of a bit error caused by an unwanted transition from 1 to 0 of the value stored to these memory cells.

Some NAND flash devices may wear out faster than expected if excessive number of bytes are set to 0. This limitation is typically documented in the data sheet of the corresponding NAND flash. For such devices it is recommended configure the Universal NAND driver to do not initialize the unused sectors with 0s. This can be realized by calling `FS_NAND_UNI_AllowBlankUnusedSectors()` with the `OnOff` parameter set to 1 in `FS_X_AddDevices()`.

6.3.3.6.2.2 FS_NAND_UNI-AllowReadErrorBadBlocks()

Description

Configures if a block is marked as defective on read fatal error.

Prototype

```
void FS_NAND_UNI-AllowReadErrorBadBlocks(U8 Unit,  
                                           U8 OnOff);
```

Parameters

Parameter	Description
<code>Unit</code>	Index of driver instance (0-based).
<code>OnOff</code>	Specifies if the feature has to be enabled or disabled <ul style="list-style-type: none">• =0 The block is not marked as defective.• ≠0 The block is marked as defective.

Additional information

This function is optional. The default behavior of the Universal NAND driver is to mark a block as defective if a read error or and uncorrectable bit error occurs while reading data from a page of that block.

6.3.3.6.2.3 FS_NAND_UNI_SetBlockRange()

Description

Specifies which NAND blocks the driver can use to store the data.

Prototype

```
void FS_NAND_UNI_SetBlockRange(U8 Unit,
                               U16 FirstBlock,
                               U16 MaxNumBlocks);
```

Parameters

Parameter	Description
<code>Unit</code>	Index of the driver instance (0-based).
<code>FirstBlock</code>	Index of the first NAND flash block to be used as storage (0-based).
<code>MaxNumBlocks</code>	Maximum number of NAND flash blocks to be used as storage.

Additional information

This function is optional. By default, the Universal NAND driver uses all blocks of the NAND flash as data storage. `FS_UNI_NAND_SetBlockRange()` is useful when a part of the NAND flash has to be used for another purpose, for example to store the application program used by a boot loader, and therefore it cannot be managed by the Universal NAND driver. Limiting the number of blocks used by the Universal NAND driver can also help reduce the RAM usage.

`FirstBlock` is the index of the first physical NAND block were 0 is the index of the first block of the NAND flash device. `MaxNumBlocks` can be larger than the actual number of available NAND blocks in which case the Universal NAND driver silently truncates the value to reflect the actual number of NAND blocks available.

The Universal NAND driver uses the first NAND block in the range to store management information at low-level format. If the first NAND block happens to be marked as defective, then the next usable NAND block is used.

If the `FS_UNI_NAND_SetBlockRange()` is used to subdivide the same physical NAND flash device into two or more partitions than the application has to make sure that the created partitions do not overlap.

The read optimization of the `FS_NAND_PHY_2048x8` physical layer has to be disabled when this function is used to partition the NAND flash device in order to ensure data consistency. The read cache can be disabled at runtime via `FS_NAND_2048x8_DisableReadCache()`.

6.3.3.6.2.4 FS_NAND_UNI_SetBlockReserve()

Description

Configures the number of NAND flash blocks to be reserved as replacement for the NAND flash blocks that become defective.

Prototype

```
void FS_NAND_UNI_SetBlockReserve(U8 Unit,  
                                unsigned pctOfBlocks);
```

Parameters

Parameter	Description
<code>Unit</code>	Index of the driver instance (0-based).
<code>pctOfBlocks</code>	Number of NAND flash blocks to be reserved as percentage of the total number of NAND flash blocks.

Additional information

This function is optional. The Universal NAND driver reserves by default about 3% of the total number of NAND flash blocks which is sufficient for most applications. Reserving more NAND flash blocks can increase the lifetime of the NAND flash device. The NAND flash device has to be low-level formatted after changing the number of reserved blocks.

6.3.3.6.2.5 FS_NAND_UNI_SetCleanThreshold()

Description

Specifies the minimum number sectors that the driver should keep available for fast write operations.

Prototype

```
int FS_NAND_UNI_SetCleanThreshold(U8          Unit,
                                  unsigned NumBlocksFree,
                                  unsigned NumSectorsFree);
```

Parameters

Parameter	Description
Unit	Index of the driver instance (0-based).
NumBlocksFree	Number of blocks to be kept free.
NumSectorsFree	Number of sectors to be kept free on each block.

Return value

= 0 OK, threshold has been set.
 ≠ 0 An error occurred.

Additional information

This function is optional. It can be used by the application to prepare the NAND flash device to write data as fast as possible once when an event occurs such as an unexpected reset. At the startup, the application reserves free space, by calling the function with `NumBlocksFree` and `NumSectorsFree` set to a value different than 0. The number of free sectors depends on the number of bytes written and on how the file system is configured. When the unexpected reset occurs, the application tells the driver that it can write to the free sectors, by calling the function with `NumBlocksFree` and `NumSectorsFree` set to 0. Then, the application writes the data to file and the NAND driver stores it to the free space. Since no erase or copy operation is required, the data is written as fastest as the NAND flash device permits it.

The NAND flash device will wear out faster than normal if sectors are reserved in a work block (`NumSectors > 0`).

Example

The following sample code demonstrates how to determine the threshold parameters.

```
#include <stdio.h>
#include "FS.h"

void SampleNAND_UNISetCleanThreshold(void) {
    unsigned NumPhyBlocks;
    unsigned NumWorkBlocks;
    FS_FILE * pFile;
    FS_NAND_DISK_INFO DiskInfo;
    FS_NAND_BLOCK_INFO BlockInfo;
    U32 BlockIndex;
    unsigned MaxNumSectors;
    unsigned NumSectorsValid;
    char ac[100];

    //
    // Get information about the storage.
    //
    memset(&DiskInfo, 0, sizeof(DiskInfo));
    FS_NAND_UNI_GetDiskInfo(0, &DiskInfo);
    NumPhyBlocks = DiskInfo.NumPhyBlocks;
    NumWorkBlocks = DiskInfo.NumWorkBlocks;
    //
    // Make sure that all work blocks are converted to data blocks.
```

```

//
FS_NAND_UNI_Clean(0, NumWorkBlocks, 0);
//
// Create a test file, write to file the data
// to be saved on sudden reset then close it.
//
pFile = FS_FOpen("Test.txt", "w");
FS_Write(pFile, "Reset", 5);
FS_FClose(pFile);
//
// Calculate how many work blocks were written
// and the maximum number of sectors written in a work block.
//
NumWorkBlocks = 0;
BlockIndex    = 0;
MaxNumSectors = 0;
do {
    memset(&BlockInfo, 0, sizeof(BlockInfo));
    FS_NAND_UNI_GetBlockInfo(0, BlockIndex++, &BlockInfo);
    if (BlockInfo.Type == FS_NAND_BLOCK_TYPE_WORK) {
        ++NumWorkBlocks;
        NumSectorsValid = BlockInfo.NumSectorsValid;
        if (MaxNumSectors < NumSectorsValid) {
            MaxNumSectors = NumSectorsValid;
        }
    }
} while (--NumPhyBlocks);
//
// Clean up: remove the test file.
//
FS_Remove("Test.txt");
//
// Show the calculated values.
// NumWorkBlocks and MaxNumSectors can be passed as 2nd and 3rd
// argument in the call to FS_NAND_UNI_SetWorkBlockReserve().
//
SEGGER_sprintf(ac, sizeof(ac), "Number of work blocks used: %u\n", NumWorkBlocks);
FS_X_Log(ac);
SEGGER_sprintf(ac, sizeof(ac), "Max. number of used sectors: %u\n", MaxNumSectors);
FS_X_Log(ac);
}

```

Sample output

```

Number of work blocks used: 1
Max. number of used sectors: 5

```

6.3.3.6.2.6 FS_NAND_UNI_SetDriverBadBlockReclamation()

Description

Configures if the bad blocks marked as defective by the driver have to be erased at low-level format or not.

Prototype

```
void FS_NAND_UNI_SetDriverBadBlockReclamation(U8 Unit,
                                              U8 OnOff);
```

Parameters

Parameter	Description
<code>Unit</code>	Index of the driver instance (0-based).
<code>OnOff</code>	Configures if the feature has to be enable or disabled. <ul style="list-style-type: none"> • =1 Defective blocks marked as such by the driver are erased at low-level format. • =0 Defective blocks marked as such by the driver are not erased at low-level format.

Additional information

This function is active only when the option `FS_NAND_RECLAIM_DRIVER_BAD_BLOCKS` is set to 1. The default behavior is to erase the blocks marked as defective by the driver.

6.3.3.6.2.7 FS_NAND_UNI_SetECCHook()

Description

Configures the ECC algorithm to be used for the correction of bit errors.

Prototype

```
void FS_NAND_UNI_SetECCHook(      U8          Unit,
                                const FS_NAND_ECC_HOOK * pECCHook);
```

Parameters

Parameter	Description
Unit	Index of the driver instance (0-based)
pECCHook	in ECC algorithm.

Additional information

This function is optional. By default, the Universal NAND driver uses an software algorithm that is capable of correcting 1 bit errors and of detecting 2 bit errors. If the NAND flash device requires a better error correction, the application has to specify an different ECC algorithm via `FS_NAND_UNI_SetECCHook()`.

The ECC algorithms can be either implemented in the software or the calculation routines can take advantage of any dedicated ECC HW available on the target system.

The following ECC algorithms are supported:

Type	Description
FS_NAND_ECC_HW_NULL	This is a pseudo ECC algorithm that requests the Universal NAND driver to use the internal HW ECC of a NAND flash device.
FS_NAND_ECC_HW_4BIT	This is a pseudo ECC algorithm that requests the Universal NAND driver to use HW 4 bit error correction. It can be used for example with dedicated a NAND flash controller that comes with a configurable HW ECC.
FS_NAND_ECC_HW_8BIT	This is a pseudo ECC algorithm that requests the Universal NAND driver to use HW 8 bit error correction. It can be used for example with dedicated a NAND flash controller that comes with a configurable HW ECC.
FS_NAND_ECC_SW_1BIT	This is an software algorithm that is able to correct 1 bit errors and detect 2 bit errors. More specifically it can correct a 1 bit error per 256 bytes of data and a 1 bit error per 4 bytes of spare area.

Additional software algorithms with error correction capabilities greater than 1 are supported via the SEGGER emLib ECC component (www.segger.com/products/security-iot/emlib/variations/ecc/).

6.3.3.6.2.8 FS_NAND_UNI_SetEraseVerification()

Description

Enables or disables the checking of the block erase operation.

Prototype

```
void FS_NAND_UNI_SetEraseVerification(U8 Unit,
                                     U8 OnOff);
```

Parameters

Parameter	Description
<code>Unit</code>	Index of the driver instance (0-based).
<code>OnOff</code>	Specifies if the feature has to be enabled or disabled <ul style="list-style-type: none"> • =0 The erase operation is not checked. • ≠0 The erase operation is checked.

Additional information

This function is optional. The result of a block erase operation is normally checked by evaluating the error bits maintained by the NAND flash device in a internal status register. `FS_NAND_UNI_SetEraseVerification()` can be used to enable additional verification of the block erase operation that is realized by reading back the contents of the entire erased physical block and by checking that all the bytes in it are set to `0xFF`. Enabling this feature can negatively impact the write performance of Universal NAND driver.

The block erase verification feature is active only when the Universal NAND driver is compiled with the `FS_NAND_VERIFY_ERASE` configuration define is set to 1 (default is 0) or when the `FS_DEBUG_LEVEL` configuration define is set to a value greater than or equal to `FS_DEBUG_LEVEL_CHECK_ALL`.

6.3.3.6.2.9 FS_NAND_UNI_SetMaxBitErrorCnt()

Description

Configures the number of bit errors that trigger the relocation of the data stored in a NAND block.

Prototype

```
void FS_NAND_UNI_SetMaxBitErrorCnt(U8 Unit,
                                   unsigned BitErrorCnt);
```

Parameters

Parameter	Description
<code>Unit</code>	Index of the driver instance (0-based).
<code>BitErrorCnt</code>	Number of physical bit errors.

Additional information

This function is optional and is active only when the file system is compiled with `FS_NAND_MAX_BIT_ERROR_CNT` set to a value greater than 0.

`FS_NAND_UNI_SetMaxBitErrorCnt()` can be used to configure when the Universal NAND Driver has to copy the contents of a NAND block to another location in order to prevent the accumulation of bit errors. `BitErrorCnt` has to be smaller than or equal to the bit error correction requirement of the NAND flash device. The feature can be disabled by calling `FS_NAND_UNI_SetMaxBitErrorCnt()` with `BitErrorCnt` set to 0.

The lifetime of the NAND flash device can be negatively affected if this feature is enabled due to the increased number of block erase operations.

6.3.3.6.2.10 FS_NAND_UNI_SetMaxEraseCntDiff()

Description

Configures the threshold of the wear leveling procedure.

Prototype

```
void FS_NAND_UNI_SetMaxEraseCntDiff(U8 Unit,
                                     U32 EraseCntDiff);
```

Parameters

Parameter	Description
<code>Unit</code>	Index of the driver instance (0-based).
<code>EraseCntDiff</code>	Maximum allowed difference between the erase counts of any two NAND blocks.

Additional information

This function is optional. It can be used to control how the Universal NAND driver performs the wear leveling. The wear leveling procedure makes sure that the NAND blocks are equally erased to meet the life expectancy of the storage device by keeping track of the number of times a NAND block has been erased (erase count). The Universal NAND driver executes this procedure when a new empty NAND block is required for data storage. The wear leveling procedure works by first choosing the next available NAND block. Then the difference between the erase count of the chosen block and the NAND block with lowest erase count is computed. If this value is greater than `EraseCntDiff` the NAND block with the lowest erase count is freed and made available for use.

The same threshold can also be configured at compile time via the `FS_NAND_MAX_ERASE_CNT_DIFF` configuration define.

6.3.3.6.2.11 FS_NAND_UNI_SetMaxPageSize()

Description

Configures the maximum handled page size.

Prototype

```
void FS_NAND_UNI_SetMaxPageSize(unsigned NumBytes);
```

Parameters

Parameter	Description
<code>NumBytes</code>	NAND page size in bytes.

Additional information

This function can be used at runtime to configure the size of the internal buffer used by the Universal NAND driver to read the data from a NAND page. This buffer is shared by all instances of the Universal NAND driver. If the application does not call `FS_NAND_UNI_SetMaxPageSize()` then the size of the internal page buffer is set to `FS_NAND_MAX_PAGE_SIZE` if `FS_NAND_MAX_PAGE_SIZE` is different than 0 or to the logical sector size of the file system if `FS_NAND_MAX_PAGE_SIZE` is set to 0.

`FS_NAND_UNI_SetMaxPageSize()` is for example useful when the application is using two NAND flash devices with different page sizes. In this case, the application has to call `FS_NAND_UNI_SetMaxPageSize()` with the `NumBytes` parameter set to the largest of the two page sizes.

`FS_NAND_UNI_SetMaxPageSize()` is available only if the file system is built with `FS_NAND_MAX_PAGE_SIZE` set to a value different than 0. The function has to be called in `FS_X_AddDevices()` before any instance of the Universal NAND driver is created.

`NumBytes` has to be a power of 2 value.

6.3.3.6.2.12 FS_NAND_UNI_SetMaxSpareAreaSize()

Description

Configures the maximum handled spare area size.

Prototype

```
void FS_NAND_UNI_SetMaxSpareAreaSize(unsigned NumBytes);
```

Parameters

Parameter	Description
NumBytes	Spare area size of the NAND page in bytes.

Additional information

This function can be used at runtime to configure the size of the internal buffer used by the Universal NAND driver to read the data from a spare area of a NAND page. This buffer is shared by all instances of the Universal NAND driver. If the application does not call `FS_NAND_UNI_SetMaxSpareAreaSize()` then the size of the internal spare area buffer is set to `FS_NAND_MAX_SPARE_AREA_SIZE` if `FS_NAND_MAX_SPARE_AREA_SIZE` is different than 0 or to 1/32 of the logical sector size of the file system if `FS_NAND_MAX_SPARE_AREA_SIZE` is set to 0.

`FS_NAND_UNI_SetMaxSpareAreaSize()` is for example useful when NAND flash device has a spare area that is larger than 1/32 of the page size. In this case, the application has to call `FS_NAND_UNI_SetMaxSpareAreaSize()` with the `NumBytes` parameter set to the spare area size specified in the data sheet of the NAND flash device.

`FS_NAND_UNI_SetMaxSpareAreaSize()` is available only if the file system is built with `FS_NAND_MAX_SPARE_AREA_SIZE` set to a value different than 0. The function has to be called in `FS_X_AddDevices()` before any instance of the Universal NAND driver is created.

6.3.3.6.2.13 FS_NAND_UNI_SetNumBlocksPerGroup()

Description

Specifies the number of physical NAND blocks in a virtual block.

Prototype

```
int FS_NAND_UNI_SetNumBlocksPerGroup(U8 Unit,
                                     unsigned BlocksPerGroup);
```

Parameters

Parameter	Description
<code>Unit</code>	Index of the driver instance (0-based).
<code>BlocksPerGroup</code>	Number of physical blocks in a virtual block. The value must be a power of 2.

Return value

= 0 OK, value configured.
 ≠ 0 Error code indicating the failure reason.

Additional information

This function is optional. It can be used to specify how many physical NAND blocks are grouped together to form a virtual block. Grouping physical blocks helps reduce the RAM usage of the driver when the NAND flash device contains a large number of physical blocks. For example, the dynamic RAM usage of the Universal NAND driver using a NAND flash device with 8196 blocks and a page size of 2048 bytes is about 20 KB. The dynamic RAM usage is reduced to about 7 KB if 4 physical blocks are grouped together.

The `FS_NAND_SUPPORT_BLOCK_GROUPING` configuration define has to be set to 1 in order to enable this function. The `FS_NAND_SUPPORT_BLOCK_GROUPING` configuration define is set to 1 by default. When set to 0 the function returns an error if called in the application.

`FS_NAND_UNI_SetNumBlocksPerGroup()` is optional and may be called only from `FS_X_AddDevices()`. Changing the block grouping requires a low-level format of the NAND flash device.

6.3.3.6.2.14 FS_NAND_UNI_SetNumWorkBlocks()

Description

Sets number of work blocks the Universal NAND driver uses for write operations.

Prototype

```
void FS_NAND_UNI_SetNumWorkBlocks(U8 Unit,
                                   U32 NumWorkBlocks);
```

Parameters

Parameter	Description
<code>Unit</code>	Index of the driver instance (0-based).
<code>NumWorkBlocks</code>	Number of work blocks.

Additional information

This function is optional. It can be used to change the default number of work blocks according to the requirements of the application. Work blocks are physical NAND blocks that the Universal NAND driver uses to temporarily store the data written to NAND flash device. The Universal NAND driver calculates at low-level format the number of work blocks based on the total number of blocks available on the NAND flash device.

By default, the NAND driver allocates 10% of the total number of NAND blocks used as storage, but no more than 10 NAND blocks. The minimum number of work blocks allocated by default depends on whether journaling is used or not. If the journal is active 4 work blocks are allocated, else Universal NAND driver allocates 3 work blocks. The currently allocated number of work blocks can be checked via `FS_NAND_UNI_GetDiskInfo()`. The value is returned in the `NumWorkBlocks` member of the `FS_NAND_DISK_INFO` structure.

Increasing the number of work blocks can help increase the write performance of the Universal NAND driver. At the same time the RAM usage of the Universal NAND driver increases since each configured work block requires a certain amount of RAM for the data management. This is a trade-off between write performance and RAM usage.

The new value take effect after the NAND flash device is low-level formatted via the `FS_FormatLow()` API function.

6.3.3.6.2.15 FS_NAND_UNI_SetOnFatalErrorCallback()

Description

Registers a function to be called by the driver when a fatal error occurs.

Prototype

```
void FS_NAND_UNI_SetOnFatalErrorCallback  
    (FS_NAND_ON_FATAL_ERROR_CALLBACK * pOnFatalError);
```

Parameters

Parameter	Description
<code>pOnFatalError</code>	Function to be called when a fatal error occurs.

Additional information

This function is optional. The application can use this function to register a routine to be called by the file system when a fatal error occurs. Typically, a fatal error occurs when the ECC is not able to correct all the bit errors in a page and is an indication that some data was lost. A data loss leads in most of the cases to a damage of the file system structure.

6.3.3.6.2.16 FS_NAND_UNI_SetPhyType()

Description

Configures NAND flash access functions.

Prototype

```
void FS_NAND_UNI_SetPhyType(      U8          Unit,
                                const FS_NAND_PHY_TYPE * pPhyType);
```

Parameters

Parameter	Description
<code>Unit</code>	Index of the driver instance (0-based)
<code>pPhyType</code>	in Physical layer to be used to access the NAND flash device.

Additional information

This function is mandatory and it has to be called in `FS_X_AddDevices()` once for each instance of the Universal NAND driver. The driver instance is identified by the `Unit` parameter. First Universal NAND driver instance added to the file system via a `FS_AddDevice(&FS_NAND_UNI_Driver)` call has the unit number 0, the Universal NAND driver added by a second call to `FS_AddDevice()` has the unit number 1 and so on.

6.3.3.6.2.17 FS_NAND_UNI_SetWriteDisturbHandling()

Description

Configures if the bit errors caused by write operations are handled or not.

Prototype

```
void FS_NAND_UNI_SetWriteDisturbHandling(U8 Unit,
                                         U8 OnOff);
```

Parameters

Parameter	Description
<code>Unit</code>	Index of the driver instance (0-based).
<code>OnOff</code>	Activation status of the feature. <ul style="list-style-type: none"> • =0 Write disturb errors are not handled (default). • ≠0 Write disturb errors are handled.

Additional information

This function is optional and is active only when the file system is compiled with `FS_NAND_MAX_BIT_ERROR_CNT` set to a value greater than 0.

A write operation can cause bit errors in the pages located on the same NAND block with the page being currently written. Normally, these bit errors are corrected later when the data of the NAND block is copied internally by the Universal NAND driver to another location on the NAND flash device during a wear leveling, a garbage collection or a write operation. This is the default behavior of the Universal NAND driver.

The Universal NAND driver is also able to check for and correct any bit errors right after the write operation in order to reduce the accumulation of bit errors that can lead to a data loss. This error handling mode can be enabled by calling `FS_NAND_UNI_SetWriteDisturbHandling()` with the `OnOff` parameter set to 1. In this error handling mode if the number of bit errors in any page in the checked NAND block is greater than or equal to the value configured via `FS_NAND_UNI_SetMaxBitErrorCnt()` then the NAND block is copied to another location on the NAND flash device in order to correct the bit errors.

The lifetime of the NAND flash device can be negatively affected if this feature is enabled due to the increased number of block erase operations. The write performance can be negatively affected as well.

6.3.3.6.2.18 FS_NAND_UNI_SetWriteVerification()

Description

Enables or disables the checking of each page write operation.

Prototype

```
void FS_NAND_UNI_SetWriteVerification(U8 Unit,
                                     U8 OnOff);
```

Parameters

Parameter	Description
<code>Unit</code>	Index of the driver instance (0-based).
<code>OnOff</code>	Specifies if the feature has to be enabled or disabled <ul style="list-style-type: none"> • =0 The write operation is not checked. • ≠0 The write operation is checked.

Additional information

This function is optional. The result of a page write operation is normally checked by evaluating the error bits maintained by the NAND flash device in a internal status register. `FS_NAND_UNI_SetWriteVerification()` can be used to enable additional verification of the page write operation that is realized by reading back the contents of the written page and by checking that all the bytes are matching the data requested to be written. Enabling this feature can negatively impact the write performance of Universal NAND driver.

The page write verification feature is active only when the Universal NAND driver is compiled with the `FS_NAND_VERIFY_WRITE` configuration define is set to 1 (default is 0) or when the `FS_DEBUG_LEVEL` configuration define is set to a value greater than or equal to `FS_DEBUG_LEVEL_CHECK_ALL`.

6.3.3.6.2.19 FS_NAND_ECC_HOOK

Description

ECC calculation algorithm.

Type definition

```
typedef struct {
    FS_NAND_ECC_HOOK_CALC * pfCalc;
    FS_NAND_ECC_HOOK_APPLY * pfApply;
    U8 NumBitsCorrectable;
    U8 ldBytesPerBlock;
    U8 NumBitsCorrectableSpare;
} FS_NAND_ECC_HOOK;
```

Structure members

Member	Description
pfCalc	Calculates the ECC of specified data.
pfApply	Verifies and corrects bit errors using ECC.
NumBitsCorrectable	Number of bits the ECC algorithm is able to correct in the data block and 4 bytes of spare area.
ldBytesPerBlock	Number of bytes in the data block given as power of 2 exponent.
NumBitsCorrectableSpare	Number of bits the ECC algorithm is able to correct in the 4 bytes of the spare area.

Additional information

This structure contains pointers to API functions and attributes related to an ECC calculation algorithm.

[ldBytesPerBlock](#) is typically set to 9 which indicates a block size of 512 bytes. The size of the ECC block is imposed by the specifications of the NAND flash device. If the value is set to 0 the Universal NAND driver assumes that the ECC block is 512 bytes large.

[NumBitsCorrectable](#) is used by the Universal NAND driver to check if the ECC algorithm is capable of correcting the number of bit errors required by the used NAND flash device.

[NumBitsCorrectableSpare](#) is used by the Universal NAND driver to activate an optimization related to reading the data from the spare area. If [NumBitsCorrectableSpare](#) is set to a value different than 0 than the Universal NAND driver assumes that the 4 bytes of management data stored in the spare area of the NAND page are protected by a dedicated ECC. This enables the Universal NAND driver to read only the spare area instead of the entire NAND page when only the management data has to be evaluated which can help increase the performance of specific operations such as the mounting of NAND flash device.

6.3.3.6.2.20 FS_NAND_ECC_HOOK_CALC

Description

Calculates the parity bits of the specified data using ECC.

Type definition

```
typedef void FS_NAND_ECC_HOOK_CALC(const U32 * pData,
                                   U8 * pSpare);
```

Parameters

Parameter	Description
<code>pData</code>	in Data to be written to the main area of the page.
<code>pSpare</code>	in Data to be written to the spare area of the page. out The calculated parity bits.

Additional information

`FS_NAND_ECC_HOOK_CALC` is called by the Universal NAND driver before it writes the data to the NAND flash device to calculate the parity check bits. The parity check bits are stored together with the data to NAND flash device. They are used by `FS_NAND_ECC_HOOK_CALC` to correct eventual bit errors.

This function has to calculate the parity bits of `pData` and of four bytes of `pSpare`. That is the calculated parity bits are used to protect the data stored in `pData` as well as `pSpare`. The number of bytes in `pData` to be protected by ECC is specified via `ldBytesPerBlock` in `FS_NAND_ECC_HOOK`. The data in `pSpare` to be protected by ECC is located at byte offset four. The calculated parity bits must be stored to `pSpare` at byte offset eight. The byte order of the stored parity bits is not relevant for the Universal NAND driver. `pSpare` is organized as follows:

Byte range	Description
0-3	Not protected by ECC
4-7	Data to be protected by ECC
8-N	Parity check bits calculated via the ECC algorithm

`FS_NAND_ECC_HOOK_CALC` is not allowed to store more than $N - 8 + 1$ parity check bytes at byte offset eight to `pSpare`. N depends on the size of the main and spare area of the NAND flash and on `ldBytesPerBlock` and can be calculate using this formula:

$$N = ((\text{BytesPerSpareArea} / (\text{BytesPerPage} \gg \text{ldBytesPerBlock})) - 8) - 1$$

Parameter	Description
<code>BytesPerSpareArea</code>	Number of bytes in the spare area of the NAND flash device
<code>BytesPerPage</code>	Number of bytes in the spare area of the NAND flash device
<code>ldBytesPerBlock</code>	Value specified in <code>FS_NAND_ECC_HOOK</code>

6.3.3.6.2.1 FS_NAND_ECC_HOOK_APPLY

Description

Checks and corrects bit errors in the specified data using ECC.

Type definition

```
typedef int FS_NAND_ECC_HOOK_APPLY(U32 * pData,
                                   U8  * pSpare);
```

Parameters

Parameter	Description
<code>pData</code>	in Data read from the main area of the page. out Corrected main area data.
<code>pSpare</code>	in Data read from the spare area of the page. out Corrected spare area data.

Return value

- < 0 Uncorrectable bit errors detected.
- ≥ 0 Number of bit errors detected and corrected.

Additional information

`FS_NAND_ECC_HOOK_APPLY` is called by the Universal NAND driver after it reads data with from the NAND flash device to verify that the data is not corrupted. If the function detects bit errors then it uses the parity check bits to correct them. The correction has to be performed in place that is directly in `pData` and `pSpare`. The parity check bits are located at byte offset eight in `pSpare`. They protect all the bytes in `pData` and four bytes of `pSpare`. Refer to `FS_NAND_ECC_HOOK_CALC` for a description of `pSpare` data layout. `FS_NAND_ECC_HOOK_APPLY` function has to also correct the bit errors that occurred in the parity check.

For backwards compatibility the return value is interpreted differently by the Universal NAND driver if `ldBytesPerBlock` is set to 0 as follows:

Value	Description
0	No error detected.
1	Bit errors corrected. Data is OK.
2	Error in ECC detected. Data is OK.
3	Uncorrectable bit error. Data is corrupted.

The Universal NAND driver can possibly call this function with `pData` set to `NULL` when it needs to check only the data stored in the spare area of a NAND page if `NumBitsCorrectableSpare` in `FS_NAND_ECC_HOOK` is set to a value different than 0.

6.3.3.7 Additional driver functions

The following functions are optional and can be used by the application to perform operations directly on the NAND flash device.

Function	Description
<code>FS_NAND_UNI_Clean()</code>	Makes storage space available for fast write operations.
<code>FS_NAND_UNI_EraseBlock()</code>	Sets all the bytes in a NAND block to 0xFF.
<code>FS_NAND_UNI_EraseFlash()</code>	Erases the entire NAND partition.
<code>FS_NAND_UNI_GetBlockInfo()</code>	Returns information about the specified NAND block.
<code>FS_NAND_UNI_GetBlockInfoEx()</code>	Returns information about the specified NAND block.
<code>FS_NAND_UNI_GetDiskInfo()</code>	Returns information about the NAND partition.
<code>FS_NAND_UNI_GetStatCounters()</code>	Returns the actual values of statistical counters.
<code>FS_NAND_UNI_IsBlockBad()</code>	Checks if a NAND block is marked as defective.
<code>FS_NAND_UNI_Mount()</code>	Mounts the NAND flash device.
<code>FS_NAND_UNI_ReadLogSectorPartial()</code>	Reads a specified number of bytes from a logical sector.
<code>FS_NAND_UNI_ReadPageRaw()</code>	Reads data from a page without ECC.
<code>FS_NAND_UNI_ReadPhySector()</code>	This function reads a physical sector from NAND flash.
<code>FS_NAND_UNI_ResetStatCounters()</code>	Sets the values of statistical counters to 0.
<code>FS_NAND_UNI_TestBlock()</code>	Fills all the pages in a block (including the spare area) with the specified pattern and verifies if the data was written correctly.
<code>FS_NAND_UNI_WritePage()</code>	Stores data to a page of a NAND flash with ECC.
<code>FS_NAND_UNI_WritePageRaw()</code>	Stores data to a page of a NAND flash without ECC.

6.3.3.7.1 FS_NAND_UNI_Clean()

Description

Makes storage space available for fast write operations.

Prototype

```
int FS_NAND_UNI_Clean(U8          Unit,
                    unsigned NumBlocksFree,
                    unsigned NumSectorsFree);
```

Parameters

Parameter	Description
<code>Unit</code>	Index of the driver instance (0-based).
<code>NumBlocksFree</code>	Number of blocks to be kept free.
<code>NumSectorsFree</code>	Number of sectors to be kept free on each block.

Return value

= 0 OK, space has been made available.
 ≠ 0 An error occurred.

Additional information

This function is optional. It can be used to free space on the NAND flash device for data that the application has to write as fast as possible. `FS_NAND_UNI_Clean()` performs two internal operations: (1) Converts all work blocks that have less free sectors than `NumSectorsFree` into data blocks. (2) If required, convert work blocks until at least `NumBlocksFree` are available.

6.3.3.7.2 FS_NAND_UNI_EraseBlock()

Description

Sets all the bytes in a NAND block to 0xFF.

Prototype

```
int FS_NAND_UNI_EraseBlock(U8 Unit,  
                           unsigned BlockIndex);
```

Parameters

Parameter	Description
<code>Unit</code>	Index of the driver instance (0-based).
<code>BlockIndex</code>	Index of the NAND flash block to be erased.

Return value

= 0 OK, block erased
≠ 0 An error occurred

Additional information

This function is optional. `FS_NAND_UNI_EraseBlock()` function does not check if the block is marked as defective before erasing it.

6.3.3.7.3 FS_NAND_UNI_EraseFlash()

Description

Erases the entire NAND partition.

Prototype

```
int FS_NAND_UNI_EraseFlash(U8 Unit);
```

Parameters

Parameter	Description
<code>Unit</code>	Index of the driver instance (0-based).

Return value

≥ 0 . Number of blocks which failed to erase.
 < 0 An error occurred.

Additional information

This function is optional. After the call to this function all the bytes in the NAND partition are set to `0xFF`.

This function has to be used with care, since it also erases blocks marked as defective and therefore the information about the block status will be lost. `FS_NAND_EraseFlash()` can be used without this side effect on storage devices that are guaranteed to not have any bad blocks, such as DataFlash devices.

6.3.3.7.4 FS_NAND_UNI_GetBlockInfo()

Description

Returns information about the specified NAND block.

Prototype

```
int FS_NAND_UNI_GetBlockInfo(U8          Unit,
                             U32        BlockIndex,
                             FS_NAND_BLOCK_INFO * pBlockInfo);
```

Parameters

Parameter	Description
<code>Unit</code>	Index of the driver instance (0-based).
<code>BlockIndex</code>	Index of the physical block to get information about.
<code>pBlockInfo</code>	out Information about the NAND block.

Return value

= 0 OK, information returned.
 ≠ 0 An error occurred.

Additional information

This function is not required for the functionality of the driver and will typically not be linked in production builds.

`FS_NAND_UNI_GetBlockInfo()` has to read the contents of the entire NAND block in order to collect all the information which may take a relatively long time to complete. If the application does not require the information about the block status or about the status of the logical sectors stored in the NAND block it can call `FS_NAND_UNI_GetBlockInfoEx()` instead.

6.3.3.7.5 FS_NAND_UNI_GetBlockInfoEx()

Description

Returns information about the specified NAND block.

Prototype

```
int FS_NAND_UNI_GetBlockInfoEx(U8          Unit,
                               U32          BlockIndex,
                               FS_NAND_BLOCK_INFO * pBlockInfo,
                               unsigned      Flags);
```

Parameters

Parameter	Description
Unit	Index of the driver instance (0-based).
BlockIndex	Index of the physical block to get information about.
pBlockInfo	out Information about the NAND block.
Flags	Specifies the information to be returned.

Return value

= 0 OK, information returned.
 ≠ 0 An error occurred.

Additional information

This function is not required for the functionality of the driver and will typically not be linked in production builds.

Flags is a bitwise OR-combination of *Block info flags* on page 580.

The `FS_NAND_BLOCK_INFO_FLAG_BAD_STATUS` flag specifies if the information about the block status has to be returned via the members `IsDriverBadBlock`, `BadBlockErrorType`, `BadBlockErrorBRSI` of `FS_NAND_BLOCK_INFO`. If `FS_NAND_UNI_GetBlockInfoEx()` is called on a NAND block marked as defective with the `FS_NAND_BLOCK_INFO_FLAG_BAD_STATUS` flag cleared than the member `Type` of `FS_NAND_BLOCK_INFO` is set to `NAND_BLOCK_TYPE_UNKNOWN`.

The `FS_NAND_BLOCK_INFO_FLAG_SECTOR_STATUS` flag specifies if `FS_NAND_UNI_GetBlockInfoEx()` has to return information about the logical sectors stored in the NAND block. This information is returned via the members `NumSectorsBlank`, `NumSectorsValid`, `NumSectorsInvalid`, `NumSectorsECCError`, `NumSectorsECCCorrectable`, `NumSectorsErrorInECC` of `FS_NAND_BLOCK_INFO`.

6.3.3.7.6 FS_NAND_UNI_GetDiskInfo()

Description

Returns information about the NAND partition.

Prototype

```
int FS_NAND_UNI_GetDiskInfo(U8 Unit,
                             FS_NAND_DISK_INFO * pDiskInfo);
```

Parameters

Parameter	Description
<code>Unit</code>	Index of the driver instance (0-based).
<code>pDiskInfo</code>	<code>out</code> Information about the NAND partition.

Return value

= 0 OK, information returned.
 ≠ 0 An error occurred.

Additional information

`FS_NAND_UNI_GetDiskInfo()` can be used to get information about the NAND flash device and about the instance of the Universal NAND driver that is used to access it. If the NAND flash device is formatted then `FS_NAND_UNI_GetDiskInfo()` also returns statistical information about the usage of NAND blocks. If this information is not relevant to the application `FS_NAND_UNI_Mount()` can be called instead which typically requires less time to complete.

`FS_NAND_UNI_GetDiskInfo()` mounts the NAND flash device if required and leaves it in this state upon return.

This function is not required for the functionality of the Universal NAND driver and is typically not linked in production builds.

6.3.3.7.7 FS_NAND_UNI_GetStatCounters()

Description

Returns the actual values of statistical counters.

Prototype

```
void FS_NAND_UNI_GetStatCounters(U8 Unit,
                                 FS_NAND_STAT_COUNTERS * pStat);
```

Parameters

Parameter	Description
<code>Unit</code>	Index of the driver instance (0-based)
<code>pStat</code>	<code>out</code> Values of statistical counters.

Additional information

This function is optional. It is active only when the file system is compiled with `FS_DEBUG_LEVEL` set to a value greater than or equal to `FS_DEBUG_LEVEL_CHECK_ALL` or `FS_NAND_ENABLE_STATS` set to 1.

The statistical counters can be cleared via `FS_NAND_UNI_ResetStatCounters()`.

6.3.3.7.8 FS_NAND_UNI_IsBlockBad()

Description

Checks if a NAND block is marked as defective.

Prototype

```
int FS_NAND_UNI_IsBlockBad(U8 Unit,  
                           unsigned BlockIndex);
```

Parameters

Parameter	Description
<code>Unit</code>	Index of the driver instance (0-based).
<code>BlockIndex</code>	Index of the NAND flash block to be checked.

Return value

1 Block is defective
0 Block is not defective

Additional information

This function is optional.

6.3.3.7.9 FS_NAND_UNI_Mount()

Description

Mounts the NAND flash device.

Prototype

```
int FS_NAND_UNI_Mount(U8 Unit,
                     FS_NAND_MOUNT_INFO * pMountInfo);
```

Parameters

Parameter	Description
<code>Unit</code>	Index of the driver instance (0-based).
<code>pMountInfo</code>	<code>out</code> Information about the mounted NAND flash device. Can be set to <code>NULL</code> .

Return value

= 0 OK, NAND flash device successfully mounted.
 ≠ 0 Error, could not mount NAND flash device.

Additional information

`FS_NAND_UNI_Mount()` can be used to explicitly mount the NAND flash device and to get information about it. This function returns a subset of the information returned by `FS_NAND_UNI_GetDiskInfo()` and therefore can be used instead of it if the application does not require statistical information about the usage of the NAND blocks. Typically, `FS_NAND_UNI_Mount()` requires less time to complete than `FS_NAND_UNI_GetDiskInfo()`.

This function is not required for the functionality of the Universal NAND driver and is typically not linked in production builds.

6.3.3.7.10 FS_NAND_UNI_ReadLogSectorPartial()

Description

Reads a specified number of bytes from a logical sector.

Prototype

```
int FS_NAND_UNI_ReadLogSectorPartial(U8          Unit,
                                     U32          LogSectorIndex,
                                     void         * pData,
                                     unsigned     Off,
                                     unsigned     NumBytes);
```

Parameters

Parameter	Description
<code>Unit</code>	Index of the driver instance (0-based).
<code>LogSectorIndex</code>	Index of the logical sector to read from.
<code>pData</code>	<code>out</code> Data read from NAND flash.
<code>Off</code>	Byte offset to read from (relative to beginning of the sector).
<code>NumBytes</code>	Number of bytes to be read.

Return value

≠ 0 Number of bytes read.
 = 0 An error occurred.

Additional information

This function is optional.

For NAND flash devices with internal HW ECC only the specified number of bytes is transferred and not the entire sector. Typ. used by the applications that access the NAND flash directly (that is without a file system) to increase the read performance.

6.3.3.7.11 FS_NAND_UNI_ReadPageRaw()

Description

Reads data from a page without ECC.

Prototype

```
int FS_NAND_UNI_ReadPageRaw(U8          Unit,
                             U32          PageIndex,
                             void        * pData,
                             unsigned    NumBytes);
```

Parameters

Parameter	Description
<code>Unit</code>	Index of the driver instance (0-based).
<code>PageIndex</code>	Index of the page to be read.
<code>pData</code>	<code>out</code> Data to be written.
<code>NumBytes</code>	Number of bytes to be read.

Return value

= 0 OK, data read.
 ≠ 0 An error occurred.

Additional information

This function is optional.

The data is read beginning from byte offset 0 in the page. If more data is requested than the page + spare area size, typ. 2 Kbytes + 64 bytes, the function does not modify the remaining bytes in `pData`.

`FS_NAND_UNI_ReadPageRaw()` does not work correctly on NAND flash devices with HW ECC that cannot be disabled.

6.3.3.7.12 FS_NAND_UNI_ReadPhySector()

Description

This function reads a physical sector from NAND flash.

Prototype

```
int FS_NAND_UNI_ReadPhySector(U8          Unit,
                              U32          PhySectorIndex,
                              void         * pData,
                              unsigned * pNumBytesData,
                              void         * pSpare,
                              unsigned * pNumBytesSpare);
```

Parameters

Parameter	Description
<code>Unit</code>	Index of the driver instance (0-based).
<code>PhySectorIndex</code>	Physical sector index.
<code>pData</code>	Pointer to a buffer to store read data.
<code>pNumBytesData</code>	<code>in</code> Pointer to variable storing the size of the data buffer. <code>out</code> The number of bytes that were stored in the data buffer.
<code>pSpare</code>	Pointer to a buffer to store read spare data.
<code>pNumBytesSpare</code>	<code>in</code> Pointer to variable storing the size of the spare data buffer. <code>out</code> The number of bytes that were stored in the spare data buffer.

Return value

≥ 0 OK, sector data read.
 < 0 An error occurred.

Additional information

This function is optional.

6.3.3.7.13 FS_NAND_UNI_ResetStatCounters()

Description

Sets the values of statistical counters to 0.

Prototype

```
void FS_NAND_UNI_ResetStatCounters(U8 Unit);
```

Parameters

Parameter	Description
<code>Unit</code>	Index of the driver instance (0-based)

Additional information

This function is optional. It is active only when the file system is compiled with `FS_DEBUG_LEVEL` set to a value greater than or equal to `FS_DEBUG_LEVEL_CHECK_ALL` or `FS_NAND_ENABLE_STATS` set to 1.

The statistical counters can be queried via `FS_NAND_UNI_GetStatCounters()`.

6.3.3.7.14 FS_NAND_UNI_TestBlock()

Description

Fills all the pages in a block (including the spare area) with the specified pattern and verifies if the data was written correctly.

Prototype

```
int FS_NAND_UNI_TestBlock(U8          Unit,
                          unsigned   BlockIndex,
                          U32        Pattern,
                          FS_NAND_TEST_INFO * pInfo);
```

Parameters

Parameter	Description
Unit	Index of the driver instance (0-based).
BlockIndex	Index of the NAND block to be tested.
Pattern	Data pattern to be written during the test.
pInfo	Additional parameters and information about the test.

Return value

FS_NAND_TEST_RETVAL_OK	OK, no bit errors.
FS_NAND_TEST_RETVAL_CORRECTABLE_ERROR	OK, correctable bit errors found. The number of bit errors is returned in NumErrorsCorrectable of pResult.
FS_NAND_TEST_RETVAL_FATAL_ERROR	Fatal error, uncorrectable bit error found. The page index is returned in PageIndexFatalError of pResult.
FS_NAND_TEST_RETVAL_BAD_BLOCK	Bad block, skipped.
FS_NAND_TEST_RETVAL_ERASE_FAILURE	Erase operation failed. The block has been marked as defective.
FS_NAND_TEST_RETVAL_WRITE_FAILURE	Write operation failed. The block has been marked as defective.
FS_NAND_TEST_RETVAL_READ_FAILURE	Read operation failed.
FS_NAND_TEST_RETVAL_INTERNAL_ERROR	NAND flash access error.

Additional information

This function is optional. It can be used by the application to test the data reliability of a NAND block. [BlockIndex](#) is relative to the beginning of the NAND partition where the first block has the index 0.

Example

The following sample code demonstrates how `FS_NAND_UNI_TestBlock()` can be used to check all the blocks of a NAND flash device. The function does not work correctly on NAND flash devices with HW ECC that cannot be disabled.

```
#include <stdio.h>
#include "FS.h"

void SampleNAND_UNITestBlocks(void) {
    int          r;
    U32          NumPhyBlocks;
    U32          iBlock;
    FS_NAND_DISK_INFO DiskInfo;
    FS_NAND_TEST_INFO TestInfo;
    char         ac[100];

    memset(&DiskInfo, 0, sizeof(DiskInfo));
    memset(&TestInfo, 0, sizeof(TestInfo));
```

```

FS_NAND_UNI_GetDiskInfo(0, &DiskInfo);
NumPhyBlocks = DiskInfo.NumPhyBlocks;
TestInfo.NumBitsCorrectable = 1;
TestInfo.BytesPerSpare = (U16)DiskInfo.BytesPerSpareArea;
for (iBlock = 0; iBlock < NumPhyBlocks; ++iBlock) {
    r = FS_NAND_UNI_TestBlock(0, iBlock, 0xAA5500FFuL, &TestInfo);
    switch (r) {
        case FS_NAND_TEST_RETVAL_OK:
            SEGGER_sprintf(ac, sizeof(ac), "Block %lu: OK.\n", iBlock);
            FS_X_Log(ac);
            break;
        case FS_NAND_TEST_RETVAL_CORRECTABLE_ERROR:
            SEGGER_sprintf(ac, sizeof(ac), "Block %lu: %lu correctable error(s).\n",
                iBlock, TestInfo.BitErrorCnt);
            FS_X_Log(ac);
            break;
        case FS_NAND_TEST_RETVAL_FATAL_ERROR:
            SEGGER_sprintf(ac, sizeof(ac),
                "Block %lu: %lu correctable error(s), fatal error on page %lu.\n",
                iBlock, TestInfo.BitErrorCnt, TestInfo.PageIndex);
            FS_X_Log(ac);
            break;
        case FS_NAND_TEST_RETVAL_BAD_BLOCK:
            SEGGER_sprintf(ac, sizeof(ac), "Block %lu: Bad. Skipped.\n", iBlock);
            FS_X_Log(ac);
            break;
        case FS_NAND_TEST_RETVAL_ERASE_FAILURE:
            SEGGER_sprintf(ac, sizeof(ac), "Block %lu: Erase failure. Marked as bad.\n", iBlock);
            FS_X_Log(ac);
            break;
        case FS_NAND_TEST_RETVAL_WRITE_FAILURE:
            SEGGER_sprintf(ac, sizeof(ac),
                "Block %lu: Write failure on page %lu. Marked as bad.\n",
                iBlock, TestInfo.PageIndex);
            FS_X_Log(ac);
            break;
        case FS_NAND_TEST_RETVAL_READ_FAILURE:
            SEGGER_sprintf(ac, sizeof(ac), "Block %lu: Read failure on page %lu.\n",
                iBlock, TestInfo.PageIndex);
            FS_X_Log(ac);
            break;
        default:
            SEGGER_sprintf(ac, sizeof(ac), "Block %lu: Internal error.\n", iBlock);
            FS_X_Log(ac);
            break;
    }
}
}
}

```

6.3.3.7.15 FS_NAND_UNI_WritePage()

Description

Stores data to a page of a NAND flash with ECC.

Prototype

```
int FS_NAND_UNI_WritePage(    U8          Unit,
                              U32          PageIndex,
                              const void    * pData,
                              unsigned      NumBytes);
```

Parameters

Parameter	Description
<code>Unit</code>	Index of the driver instance (0-based).
<code>PageIndex</code>	Index of the page to be written.
<code>pData</code>	<code>in</code> Data to be written.
<code>NumBytes</code>	Number of bytes to be written.

Return value

= 0 OK, data written.
 ≠ 0 An error occurred.

Additional information

This function is optional.

The data is written beginning with the byte offset 0 in the page. If more data is written than the size of the page, typically 2 KB + 64 bytes, the excess bytes are discarded. Data in the area reserved for ECC cannot be written using this function and it will be overwritten.

6.3.3.7.16 FS_NAND_UNI_WritePageRaw()

Description

Stores data to a page of a NAND flash without ECC.

Prototype

```
int FS_NAND_UNI_WritePageRaw(    U8          Unit,
                                U32          PageIndex,
                                const void    * pData,
                                unsigned     NumBytes);
```

Parameters

Parameter	Description
Unit	Index of the driver instance (0-based).
PageIndex	Index of the page to be written.
pData	in Data to be written.
NumBytes	Number of bytes to be written.

Return value

= 0 OK, data written.
 ≠ 0 An error occurred.

Additional information

This function is optional.

The data is written beginning at the byte offset 0 in the page. If more data is written than the size of the page + spare area, typ. 2 Kbytes + 64 bytes, the excess bytes are ignored.

`FS_NAND_UNI_WritePageRaw()` does not work correctly on NAND flash devices with HW ECC that cannot be disabled.

6.3.3.7.17 Bad block marking types

Description

Methods to mark a block as defective.

Definition

```
#define FS_NAND_BAD_BLOCK_MARKING_TYPE_FSPS 0
#define FS_NAND_BAD_BLOCK_MARKING_TYPE_FPS 1
#define FS_NAND_BAD_BLOCK_MARKING_TYPE_FLPS 2
#define FS_NAND_BAD_BLOCK_MARKING_TYPE_FSLPS 3
#define FS_NAND_BAD_BLOCK_MARKING_TYPE_FLPMS 4
```

Symbols

Definition	Description
<code>FS_NAND_BAD_BLOCK_MARKING_TYPE_FSPS</code>	The block is marked as defective in the spare area of the first and second page of the block.
<code>FS_NAND_BAD_BLOCK_MARKING_TYPE_FPS</code>	The block is marked as defective in the spare area of the first page of the block.
<code>FS_NAND_BAD_BLOCK_MARKING_TYPE_FLPS</code>	The block is marked as defective in the spare area of first and last page of the block.
<code>FS_NAND_BAD_BLOCK_MARKING_TYPE_FSLPS</code>	The block is marked as defective in the spare area of first, second and last page of the block.
<code>FS_NAND_BAD_BLOCK_MARKING_TYPE_FLPMS</code>	The block is marked as defective in the main and spare area of first and last page of the block.

6.3.3.7.18 Block info flags

Description

Flags that control the information returned by `FS_NAND_UNI_GetBlockInfoEx()`.

Definition

```
#define FS_NAND_BLOCK_INFO_FLAG_BAD_STATUS      0x01u
#define FS_NAND_BLOCK_INFO_FLAG_SECTOR_STATUS  0x02u
```

Symbols

Definition	Description
<code>FS_NAND_BLOCK_INFO_FLAG_BAD_STATUS</code>	Return information about the status of the NAND block (defective or not)
<code>FS_NAND_BLOCK_INFO_FLAG_SECTOR_STATUS</code>	Return information about the status of all logical sectors in the NAND block.

Additional information

These flags can be passed as `Flags` parameter to `FS_NAND_UNI_GetBlockInfoEx()` in order to specify the type of information that has to be returned.

6.3.3.7.19 ECC correction status

Description

Result of the bit error correction.

Definition

```
#define FS_NAND_CORR_NOT_APPLIED    0u
#define FS_NAND_CORR_APPLIED       1u
#define FS_NAND_CORR_FAILURE       2u
```

Symbols

Definition	Description
FS_NAND_CORR_NOT_APPLIED	No bit errors detected.
FS_NAND_CORR_APPLIED	Bit errors were detected and corrected.
FS_NAND_CORR_FAILURE	Bit errors were detected but not corrected.

6.3.3.7.20 FS_NAND_MOUNT_INFO

Description

Information about the mounted NAND flash device.

Type definition

```
typedef struct {
    U32  NumPhyBlocks;
    U32  NumLogBlocks;
    U32  NumPagesPerBlock;
    U32  NumSectorsPerBlock;
    U32  BytesPerPage;
    U32  BytesPerSpareArea;
    U32  BytesPerSector;
    U8   BadBlockMarkingType;
    U8   IsWriteProtected;
    U8   HasFatalError;
    U8   ErrorType;
    U32  ErrorSectorIndex;
    U16  BlocksPerGroup;
    U32  NumWorkBlocks;
} FS_NAND_MOUNT_INFO;
```

Structure members

Member	Description
NumPhyBlocks	Total number of blocks in the NAND partition.
NumLogBlocks	Total number of NAND blocks that can be used to store data.
NumPagesPerBlock	Number of pages in a NAND block.
NumSectorsPerBlock	Number of logical sectors stored in a NAND block.
BytesPerPage	Number of bytes in the main area of a NAND page.
BytesPerSpareArea	Number of bytes in the spare area of a NAND page.
BytesPerSector	Number of bytes is a logical sector.
BadBlockMarkingType	Type of the bad block marking.
IsWriteProtected	Set to 1 if the NAND flash device cannot be written.
HasFatalError	Set to 1 if the SLC1 NAND driver reported a fatal error.
ErrorType	Type of fatal error that has occurred.
ErrorSectorIndex	Sector index on which a fatal error occurred.
BlocksPerGroup	Number of NAND blocks in a group.
NumWorkBlocks	Number of work blocks used by the SLC1 NAND driver.

6.3.3.7.21 FS_NAND_STAT_COUNTERS

Description

Statistical counters of NAND flash driver.

Type definition

```
typedef struct {
    U32  NumFreeBlocks;
    U32  NumBadBlocks;
    U32  EraseCnt;
    U32  ReadDataCnt;
    U32  ReadSpareCnt;
    U32  ReadSectorCnt;
    U32  NumReadRetries;
    U32  WriteDataCnt;
    U32  WriteSpareCnt;
    U32  WriteSectorCnt;
    U32  NumWriteRetries;
    U32  ConvertViaCopyCnt;
    U32  ConvertInPlaceCnt;
    U32  NumValidSectors;
    U32  CopySectorCnt;
    U32  BlockRelocationCnt;
    U32  ReadByteCnt;
    U32  WriteByteCnt;
    U32  BitErrorCnt;
    U32  aBitErrorCnt[];
} FS_NAND_STAT_COUNTERS;
```

Structure members

Member	Description
NumFreeBlocks	Number of NAND blocks not used for data.
NumBadBlocks	Number of NAND blocks marked as defective.
EraseCnt	Number of block erase operation performed.
ReadDataCnt	Number of times the NAND driver read from the main area of a page.
ReadSpareCnt	Number of times the NAND driver read from the spare area of a page.
ReadSectorCnt	Number of logical sectors read from the NAND flash.
NumReadRetries	Number of times a read operation has been retried because of an error.
WriteDataCnt	Number of times the NAND driver wrote to the main area of a page.
WriteSpareCnt	Number of times the NAND driver wrote to the spare area of a page.
WriteSectorCnt	Number of logical sectors wrote to the NAND flash.
NumWriteRetries	Number of times a write operation has been retried because of an error.
ConvertViaCopyCnt	Number of block conversions via copy.
ConvertInPlaceCnt	Number of block conversions in place.
NumValidSectors	Number of logical sectors that contain valid data.
CopySectorCnt	Number of times the NAND driver copied a logical sector to another location.
BlockRelocationCnt	Number of times the NAND driver relocated a NAND block due to errors.

Member	Description
<code>ReadByteCnt</code>	Number of bytes read from NAND flash.
<code>WriteByteCnt</code>	Number of bytes written to NAND flash.
<code>BitErrorCnt</code>	Number of bit errors detected and corrected.
<code>aBitErrorCnt</code>	Number of times a specific number of bit errors occurred.

Additional information

This structure can be used to get statistical information about the operation of the Universal as well as SLC1 NAND driver via the function `FS_NAND_UNI_GetStatCounters()` and `FS_NAND_GetStatCounters()` respectively.

`aBitErrorCnt[0]` stores the number of 1 bit error occurrences, `aBitErrorCnt[1]` stores the number of 2 bit error occurrences, and so on.

Example

Refer to `FS_NAND_UNI_GetStatCounters()` and `FS_NAND_GetStatCounters()` for a sample usage.

6.3.3.7.22 FS_NAND_TEST_INFO

Description

Additional information passed to test routine.

Type definition

```
typedef struct {
    U8    NumBitsCorrectable;
    U8    OffSpareECCProt;
    U8    NumBytesSpareECCProt;
    U16   BytesPerSpare;
    U32   BitErrorCnt;
    U32   PageIndex;
} FS_NAND_TEST_INFO;
```

Structure members

Member	Description
NumBitsCorrectable	Number of bits the ECC can correct in the data and spare area (typically 4)
OffSpareECCProt	Offset in the spare area of the first byte protected by ECC (typically 4).
NumBytesSpareECCProt	Number of bytes in the spare area protected by ECC (typically 4 bytes)
BytesPerSpare	Total number of bytes in the spare area. When set to 0 the default value of 1/32 of page size is used.
BitErrorCnt	Number of bit errors detected and corrected.
PageIndex	Index of the physical page where the error happened.

Additional information

The test routine returns information about what went wrong during a test via `FS_NAND_UNI_TestBlock()` and `FS_NAND_TestBlock()`.

Example

Refer to `FS_NAND_UNI_TestBlock()` and `FS_NAND_TestBlock()` for a sample usage.

6.3.3.7.23 NAND block types

Description

Type of data stored to a NAND block.

Definition

```
#define FS_NAND_BLOCK_TYPE_UNKNOWN    0u
#define FS_NAND_BLOCK_TYPE_BAD       1u
#define FS_NAND_BLOCK_TYPE_EMPTY     2u
#define FS_NAND_BLOCK_TYPE_WORK      3u
#define FS_NAND_BLOCK_TYPE_DATA      4u
```

Symbols

Definition	Description
FS_NAND_BLOCK_TYPE_UNKNOWN	The type of the block cannot be determined.
FS_NAND_BLOCK_TYPE_BAD	The block marked as defective.
FS_NAND_BLOCK_TYPE_EMPTY	The block does not store any data.
FS_NAND_BLOCK_TYPE_WORK	The block that stores data temporarily.
FS_NAND_BLOCK_TYPE_DATA	The block that stores data permanently.

6.3.3.7.24 NAND test return values

Description

Return values of the NAND block test functions.

Definition

```
#define FS_NAND_TEST_RETVAL_OK                0
#define FS_NAND_TEST_RETVAL_CORRECTABLE_ERROR 1
#define FS_NAND_TEST_RETVAL_FATAL_ERROR       2
#define FS_NAND_TEST_RETVAL_BAD_BLOCK        3
#define FS_NAND_TEST_RETVAL_ERASE_FAILURE    4
#define FS_NAND_TEST_RETVAL_WRITE_FAILURE    5
#define FS_NAND_TEST_RETVAL_READ_FAILURE     6
#define FS_NAND_TEST_RETVAL_INTERNAL_ERROR   (-1)
```

Symbols

Definition	Description
FS_NAND_TEST_RETVAL_OK	The test was successful.
FS_NAND_TEST_RETVAL_CORRECTABLE_ERROR	Bit errors occurred that were corrected via ECC.
FS_NAND_TEST_RETVAL_FATAL_ERROR	Bit errors occurred that the ECC was not able to correct.
FS_NAND_TEST_RETVAL_BAD_BLOCK	The tested block was marked as defective.
FS_NAND_TEST_RETVAL_ERASE_FAILURE	An error occurred during the block erase operation.
FS_NAND_TEST_RETVAL_WRITE_FAILURE	An error occurred while writing the data to the NAND block.
FS_NAND_TEST_RETVAL_READ_FAILURE	An error occurred while reading the data from the NAND block.
FS_NAND_TEST_RETVAL_INTERNAL_ERROR	An internal processing error occurred.

6.3.3.8 Performance and resource usage

This section provides information about the ROM and RAM usage as well as the performance of the Universal NAND driver. Please note that a Universal NAND driver instance requires one instance of one NAND physical layer in order to operate. The resource usage of the used NAND physical layer has to be taken into account when calculating the total resource usage of the Universal NAND driver.

6.3.3.8.1 ROM usage

The ROM usage depends on the compiler options, the compiler version and the used CPU. The memory requirements of the Universal NAND driver were measured as described in the section *Test procedure* on page 1283.

Usage: 7.9 Kbytes

6.3.3.8.2 Static RAM usage

Static RAM usage refers to the amount of RAM required by the Universal NAND driver internally for all the driver instances. The number of bytes can be seen in the compiler list file of the `{FS_NAND_UNI_Drv.c}` file.

Usage: 32 bytes

6.3.3.8.3 Dynamic RAM usage

Dynamic RAM usage is the amount of RAM allocated by the driver at runtime. The amount required depends on the runtime configuration and the characteristics of the used NAND flash device. The approximate RAM usage of the Universal NAND driver can be calculated as follows:

```
MemAllocated = 148 + 2 * NumBlocks
              + ((PagesPerBlock - 1) + 18) * NumWorkBlocks
              + 1.04 * PageSize
```

Parameter	Description
MemAllocated	Number of bytes allocated for one instance of the NAND driver.
NumBlocks	Number of blocks in the NAND flash device.
NumWorkBlocks	Number of blocks the driver reserves as temporary storage for the written data. By default, 3 blocks are reserved. The number of work blocks can be specified at runtime via <code>FS_NAND_UNI_SetNumWorkBlocks()</code> .
PageSize	Number of bytes in a page.

Example

This example uses a 2 GBit NAND flash device with 2Kbyte pages and 2048 blocks. One block consists of 64 pages and each page holds 1 sector of 2048 bytes.

```
PagesPerBlock = 64
NumBlocks     = 2048
NumWorkBlocks = 4
PageSize      = 2048
MemAllocated  = 148 + 2 * 2048 + (64 - 1 + 18) * 4 + 1.04 * 2048
              = 148 + 4096 + 324 + 2129
              = 6397 bytes
```

6.3.3.8.4 Performance

The following performance measurements are in no way complete, but they give a good approximation of time required for common operations on various target hardware. The

tests were performed as described in the section *Performance* on page 1289. All values are given in Mbytes/sec.

CPU type	NAND flash device	Write speed	Read speed
NXP LPC4322 (180 MHz)	Serial NAND flash with 2048 bytes per page connected to a quad SPI controller via 4 data lines transferring data at 60 MHz.	4.1	12.2
NXP LPC4322 (180 MHz)	Serial NAND flash with 2048 bytes per page connected to a standard SPI controller transferring data at 60 MHz.	3.9	7.7
ST STM32MP157 (650 MHz)	Parallel NAND flash with 4096 bytes per page connected to external memory controller via an 8-bit data bus. The 8-bit ECC is calculated using SEGGER em-File-ECC.	10.8	22.2
Atmel AT91SAM3U (96 MHz)	Parallel NAND flash with 2048 bytes per page and a sector size of 2048 bytes with internal ECC enabled using the built in NAND controller/external bus-interface.	2.6	7.5

6.3.4 NAND physical layer

6.3.4.1 General information

The NAND physical layer provides the basic functionality for accessing a NAND flash device such as device identification, block erase operation, page read and write operations, etc. Every instance of the Universal or SLC1 NAND driver requires an instance of a NAND physical layer in order to be able to operate. A NAND physical layer instance is automatically allocated either statically or dynamically at the first call to one of its API functions. Each instance is identified by a unit number that is identical with the unit number of the NAND driver that uses that instance of the NAND physical layer. The type of the NAND physical layer assigned to an instance of a Universal or SLC1 NAND driver is configured via `FS_NAND_UNI_SetPhyType()` and `FS_NAND_SetPhyType()` respectively.

The table below lists the NAND physical layers that ship with emFile. Refer to *Configuring the driver* on page 489 and *Configuring the driver* on page 532 for detailed information about how to add and configure a physical layer in an application.

Physical layer identifier	Works with Universal NAND driver?	Works with SLC1 NAND driver?	Hardware layer type
FS_NAND_PHY_512x8	no	yes	FS_NAND_HW_TYPE
FS_NAND_PHY_2048x8	yes	yes	FS_NAND_HW_TYPE
FS_NAND_PHY_2048x8_Two-Plane	yes	yes	FS_NAND_HW_TYPE
FS_NAND_PHY_2048x8_Small	yes	yes	FS_NAND_HW_TYPE
FS_NAND_PHY_2048x16	yes	yes	FS_NAND_HW_TYPE
FS_NAND_PHY_4096x8	yes	yes	FS_NAND_HW_TYPE
FS_NAND_PHY_DataFlash	no	yes	FS_NAND_HW_TYPE_DF
FS_NAND_PHY_ONFI	yes	yes	FS_NAND_HW_TYPE
FS_NAND_PHY_ONFI_RO	yes	yes	FS_NAND_HW_TYPE
FS_NAND_PHY_ONFI_Small	yes	yes	FS_NAND_HW_TYPE
FS_NAND_PHY_QSPI	yes	no	FS_NAND_HW_TYPE_QSPI
FS_NAND_PHY_SPI	yes	no	FS_NAND_HW_TYPE_SPI
FS_NAND_PHY_x	yes	yes	FS_NAND_HW_TYPE
FS_NAND_PHY_x8	yes	yes	FS_NAND_HW_TYPE

The following sections provide information about the usage and the implementation of a NAND physical layer.

6.3.4.2 512x8 physical layer

This NAND physical layer supports any NAND flash device with a page size of 512 bytes and a spare area of 16 bytes that is connected to MCU via an 8-bit data bus. It works only with the SLC1 NAND driver because the size of the spare area is not sufficiently large for the amount of management data required by the Universal NAND driver. The instances of this physical layer are allocated statically. The maximum number of instances can be configured at compile time via `FS_NAND_NUM_UNITS`.

6.3.4.2.1 Runtime configuration

The API functions listed in the following table can be used by the application to configure the behavior of the 512x8 physical layer. The application can call them only at the file system initialization in `FS_X_AddDevices()`.

Function	Description
<code>FS_NAND_512x8_SetHWType()</code>	Configures the hardware access routines for a NAND physical layer of type <code>FS_NAND_PHY_512x8</code> .

6.3.4.2.1.1 FS_NAND_512x8_SetHWType()

Description

Configures the hardware access routines for a NAND physical layer of type `FS_NAND_PHY_512x8`.

Prototype

```
void FS_NAND_512x8_SetHWType(      U8          Unit,  
                                const FS_NAND_HW_TYPE * pHWType);
```

Parameters

Parameter	Description
<code>Unit</code>	Index of the physical layer instance (0-based)
<code>pHWType</code>	Type of the hardware layer to use. Cannot be <code>NULL</code> .

Additional information

This function is mandatory and has to be called once in `FS_X_AddDevices()` for every instance of a NAND physical layer of type `FS_NAND_PHY_512x8`.

6.3.4.3 2048x8 physical layer

This NAND physical layer supports any NAND flash device with a page size of 2048 bytes and a spare area larger than or equal to 64 bytes that is connected to MCU via an 8-bit data bus. The instances of this physical layer are allocated dynamically. The maximum number of instances can be configured at compile time via `FS_NAND_NUM_UNITS`.

6.3.4.3.1 Compile time configuration

The 2048x8 physical layer can optionally be configured at compile time. Typically, this step can be omitted because reasonable default values are provided that work with most of the applications. The following table provides a summary of the configuration defines supported by this physical layer.

Define	Default value	Type	Description
<code>FS_NAND_2048X8_DEVICE_LIST_DEFAULT</code>	<code>&FS_NAND_2048X8_DeviceListDefault</code>	R	List of parallel NAND flash devices that can be handled by the physical layer.
<code>FS_NAND_SUPPORT_READ_CACHE</code>	0	B	Specifies if the internal page register of the NAND flash device should be used as read cache.

6.3.4.3.1.1 FS_NAND_2048X8_DEVICE_LIST_DEFAULT

`FS_NAND_2048X8_DEVICE_LIST_DEFAULT` specifies the list of parallel NAND flash devices that can be handled by the physical layer. It can be set to `NULL` in order to reduce the ROM usage if not all the devices included in `FS_NAND_2048X8_DeviceListDefault` have to be handled. In this case it is mandatory that the application configures a list of devices via `FS_NAND_2048X8_SetDeviceList()`.

6.3.4.3.1.2 FS_NAND_SUPPORT_READ_CACHE

With `FS_NAND_SUPPORT_READ_CACHE` set to 1 the physical layer keeps track of the index of the last page read from NAND flash device. If the same page is read again then the physical layer omits the operation that transfers the page data from the memory array to the internal page register of the NAND flash device. In this case only a data transfer from the internal page register to host is executed which helps improve the performance.

Note

This feature cannot be used if the NAND flash device is partitioned via either `FS_NAND_SetBlockRange()` or `FS_NAND_UNI_SetBlockRange()` and the created partitions are accessed via the file system.

6.3.4.3.2 Runtime configuration

The API functions listed in the following table can be used by the application to configure the behavior of the 2048x8 physical layer. The application can call them only at the file system initialization in `FS_X_AddDevices()`.

Function	Description
<code>FS_NAND_2048x8_DisableReadCache()</code>	Deactivates the page read optimization.
<code>FS_NAND_2048x8_EnableReadCache()</code>	Activates the page read optimization.
<code>FS_NAND_2048X8_SetDeviceList()</code>	Specifies the list of NAND flash devices that require special handling.
<code>FS_NAND_2048x8_SetHWType()</code>	Configures the hardware access routines for a NAND physical layer of type <code>FS_NAND_PHY_2048x8</code> .

6.3.4.3.2.1 FS_NAND_2048x8_DisableReadCache()

Description

Deactivates the page read optimization.

Prototype

```
void FS_NAND_2048x8_DisableReadCache(U8 Unit);
```

Parameters

Parameter	Description
Unit	Index of the physical layer instance (0-based)

Additional information

This function is optional and is available only when the file system is build with `FS_NAND_SUPPORT_READ_CACHE` set to 1 which is the default. The optimization can be enabled at runtime via `FS_NAND_2048x8_EnableReadCache()`.

Refer to `FS_NAND_2048x8_EnableReadCache()` for more information about how the page read optimization works

6.3.4.3.2.2 FS_NAND_2048x8_EnableReadCache()

Description

Activates the page read optimization.

Prototype

```
void FS_NAND_2048x8_EnableReadCache(U8 Unit);
```

Parameters

Parameter	Description
Unit	Index of the physical layer instance (0-based)

Additional information

This function is optional and is available only when the file system is build with `FS_NAND_SUPPORT_READ_CACHE` set to 1 which is the default. Activating the read cache can increase the overall performance of the NAND driver especially when using the SLC1 NAND driver with a logical sector size smaller than the page of the used NAND flash device.

The optimization takes advantage of how the NAND flash device implements the read page operation. A NAND page read operation consists of two steps. In the first step, the page data is read from the memory array to internal page register of the NAND flash device. In the second step, the data is transferred from the internal page register of NAND flash device to MCU. With the optimization enabled the first step is skipped whenever possible.

The optimization is enabled by default and has to be disabled if two or more instances of the NAND driver are configured to access the same physical NAND flash device. At runtime, the optimization can be disabled via `FS_NAND_2048x8_DisableReadCache()`.

6.3.4.3.2.3 FS_NAND_2048X8_SetDeviceList()

Description

Specifies the list of NAND flash devices that require special handling.

Prototype

```
void FS_NAND_2048X8_SetDeviceList(      U8          Unit,
                                       const FS_NAND_2048X8_DEVICE_LIST * pDeviceList);
```

Parameters

Parameter	Description
<code>Unit</code>	Index of the physical layer (0-based)
<code>pDeviceList</code>	in List of NAND flash devices.

Additional information

NAND flash devices that do not require special handling such as devices without HW ECC are always enabled. The special handling is required for example to determine if the HW ECC of the NAND flash device can be enabled and disabled at runtime.

By default, only special handling for NAND flash devices from Samsung and Toshiba is enabled (`FS_NAND_ONFI_DeviceListDefault`). The correct operation of NAND flash device from a manufacturer not included in the configured list of devices is not guaranteed if the the NAND flash device requires special handling.

Permitted values for the `pDeviceList` parameter are:

Identifier	Description
<code>FS_NAND_2048X8_DeviceListAll</code>	Enables the handling for all supported NAND flash devices.
<code>FS_NAND_2048X8_DeviceListDefault</code>	Enables the handling of standard NAND flash devices and the special handling of Samsung and Toshiba NAND flashes.
<code>FS_NAND_2048X8_DeviceListStandard</code>	Enables the handling of NAND flash devices that do not have any special features such as HW ECC.
<code>FS_NAND_2048X8_DeviceListSamsung</code>	Enables the special handling of Samsung NAND flash devices.
<code>FS_NAND_2048X8_DeviceListToshiba</code>	Enables the special handling of Toshiba NAND flash devices.

6.3.4.3.2.4 FS_NAND_2048x8_SetHWType()

Description

Configures the hardware access routines for a NAND physical layer of type FS_NAND_PHY_2048x8.

Prototype

```
void FS_NAND_2048x8_SetHWType(      U8          Unit,  
                                 const FS_NAND_HW_TYPE * pHWType);
```

Parameters

Parameter	Description
Unit	Index of the physical layer instance (0-based)
pHWType	Type of the hardware layer to use. Cannot be NULL.

Additional information

This function is mandatory and has to be called once in FS_X_AddDevices() for every instance of a NAND physical layer of type FS_NAND_PHY_2048x8.

6.3.4.4 Two plane 2048x8 physical layer

This NAND physical layer supports any NAND flash device with a page size of 2048 bytes and a spare area larger than or equal to 64 bytes that is connected to MCU via an 8-bit data bus. In addition, the NAND flash device has to be organized in two planes and provide support for executing an operation on both planes simultaneously. The instances of this physical layer are allocated dynamically. The maximum number of instances can be configured at build time via `FS_NAND_NUM_UNITS`.

`FS_NAND_PHY_2048x8_TwoPlane` uses the same runtime functions and compile time configuration defines as `FS_NAND_PHY_2048x8`.

6.3.4.5 Small 2048x8 physical layer

This physical layer is a variant of `FS_NAND_PHY_2048x8` with reduced ROM usage. `FS_NAND_PHY_2048x8_Small` supports the same NAND flash devices as `FS_NAND_PHY_2048x8` but it does not provide support for the NAND internal page copy operation and for the reading the ECC correction result. `FS_NAND_PHY_2048x8_Small` provides read as well as write access to NAND flash device. The instances of this physical layer are allocated statically.

`FS_NAND_PHY_2048x8_Small` uses the same runtime functions and compile time configuration defines as `FS_NAND_PHY_2048x8`.

6.3.4.6 2048x16 physical layer

This physical layer supports NAND flash devices with page size of 2048 bytes and a spare area larger than or equal to 64 bytes that is connected to MCU via an 16-bit data bus. The instances of this physical layer are allocated statically. The maximum number of instances can be configured at build time via `FS_NAND_NUM_UNITS`.

6.3.4.6.1 Runtime configuration

The API functions listed in the following table can be used by the application to configure the behavior of the 2048x16 physical layer. The application can call them only at the file system initialization in `FS_X_AddDevices()`.

Function	Description
<code>FS_NAND_2048x16_SetHWType()</code>	Configures the hardware access routines for a NAND physical layer of type <code>FS_NAND_PHY_2048x16</code> .

6.3.4.6.1.1 FS_NAND_2048x16_SetHWType()

Description

Configures the hardware access routines for a NAND physical layer of type `FS_NAND_PHY_2048x16`.

Prototype

```
void FS_NAND_2048x16_SetHWType(      U8          Unit,  
                                   const FS_NAND_HW_TYPE * pHWType);
```

Parameters

Parameter	Description
<code>Unit</code>	Index of the physical layer instance (0-based)
<code>pHWType</code>	Type of the hardware layer to use. Cannot be <code>NULL</code> .

Additional information

This function is mandatory and has to be called once in `FS_X_AddDevices()` for every instance of a NAND physical layer of type `FS_NAND_PHY_2048x16`.

6.3.4.7 4096x8 physical layer

This NAND physical layer supports any NAND flash device with a page size of 4096 bytes and a spare area larger than or equal to 128 bytes that is connected to MCU via an 8-bit data bus. The instances of this physical layer are allocated statically. The maximum number of instances can be configured at build time via `FS_NAND_NUM_UNITS`.

6.3.4.7.1 Runtime configuration

The API functions listed in the following table can be used by the application to configure the behavior of the 4096x8 physical layer. The application can call them only at the file system initialization in `FS_X_AddDevices()`.

Function	Description
<code>FS_NAND_4096x8_SetHWType()</code>	Configures the hardware access routines for a NAND physical layer of type <code>FS_NAND_PHY_4096x8</code> .

6.3.4.7.1.1 FS_NAND_4096x8_SetHWType()

Description

Configures the hardware access routines for a NAND physical layer of type FS_NAND_PHY_4096x8.

Prototype

```
void FS_NAND_4096x8_SetHWType(      U8          Unit,  
                                 const FS_NAND_HW_TYPE * pHWType);
```

Parameters

Parameter	Description
Unit	Index of the physical layer instance (0-based)
pHWType	Type of the hardware layer to use. Cannot be NULL.

Additional information

This function is mandatory and has to be called once in FS_X_AddDevices() for every instance of a NAND physical layer of type FS_NAND_PHY_4096x8.

6.3.4.8 DataFlash physical layer

This physical layer supports Dialog Semiconductor / Adesto / Atmel DataFlash storage devices. The devices are accessed via SPI using a hardware layer of type `FS_NAND_HW_TYPE_DF`. `FS_NAND_PHY_DataFlash` works only with the SLC1 NAND driver because the size of the spare area is not sufficiently large for the amount of management data required by the Universal NAND driver. The instances of this physical layer are allocated statically.

6.3.4.8.1 Compile time configuration

The DataFlash physical layer can optionally be configured at compile time. Typically, this step can be omitted because reasonable default values are provided that work with most of the applications. The following table provides a summary of the configuration defines supported by this physical layer.

Define	Default value	Type	Description
<code>FS_NAND_BLOCK_TYPE</code>	2	N	Specifies the size of the erase unit.
<code>FS_NAND_SUPPORT_READ_CACHE</code>	0	B	Specifies if the internal page register of the DataFlash device should be used as read cache.

6.3.4.8.1.1 FS_NAND_BLOCK_TYPE

`FS_NAND_BLOCK_TYPE` can be used to specify the size of the erase unit used by the DataFlash physical layer. The following erase unit sizes are supported: 1 block large (`FS_NAND_BLOCK_TYPE = 0`), 8 blocks large (`FS_NAND_BLOCK_TYPE = 1`) and 1 sector large (`FS_NAND_BLOCK_TYPE = 2`). By default `FS_NAND_BLOCK_TYPE` is set 2 because it ensures the maximum performance.

Note

The physical layer is not fail-safe when `FS_NAND_BLOCK_TYPE` is set to 1 because more than one erase operation has to be performed in order to erase the entire block.

6.3.4.8.1.2 FS_NAND_SUPPORT_READ_CACHE

With `FS_NAND_SUPPORT_READ_CACHE` set to 1 the physical layer keeps track of the index of the last page read from DataFlash flash device. If the same page is read again then the physical layer omits the operation that transfers the page data from the memory array to the internal page register of the DataFlash flash device. In this case only a data transfer from the internal page register to host is executed which helps improve the performance.

Note

This feature cannot be used if the DataFlash device is partitioned via `FS_NAND_SetBlockRange()` and the created partitions are accessed via the file system.

6.3.4.8.2 Runtime configuration

The API functions listed in the following table can be used by the application to configure the behavior of the DataFlash physical layer. The application can call them only at the file system initialization in `FS_X_AddDevices()`.

Function	Description
<code>FS_NAND_DF_EraseChip()</code>	Erases the entire device.
<code>FS_NAND_DF_SetMinPageSize()</code>	Configures the required minimum page size.

Function	Description
FS_NAND_DF_SetHWType()	Configures the hardware access routines.

6.3.4.8.2.1 FS_NAND_DF_EraseChip()

Description

Erases the entire device.

Prototype

```
void FS_NAND_DF_EraseChip(U8 Unit);
```

Parameters

Parameter	Description
Unit	Index of the physical layer (0-based)

Additional information

This function is optional. It sets all the bits of the DataFlash memory to 1. All the data stored on the DataFlash memory is lost.

6.3.4.8.2.2 FS_NAND_DF_SetMinPageSize()

Description

Configures the required minimum page size.

Prototype

```
void FS_NAND_DF_SetMinPageSize(U8 Unit,  
                               U32 NumBytes);
```

Parameters

Parameter	Description
Unit	Index of the physical layer (0-based)
NumBytes	Page size in bytes.

Additional information

This function is optional. The application can use it to request a minimum page size to work with. If the size of the physical page is smaller than the specified value then adjacent physical pages are grouped together into one virtual page that is presented as a single page to the SLC1 NAND driver. This is required when the size of a physical page is smaller than 512 bytes which is the minimum sector size the SLC1 NAND driver can work with. [NumBytes](#) has to be a power of 2 value.

6.3.4.8.2.3 FS_NAND_DF_SetHWType()

Description

Configures the hardware access routines.

Prototype

```
void FS_NAND_DF_SetHWType(      U8          Unit,  
                             const FS_NAND_HW_TYPE_DF * pHWType);
```

Parameters

Parameter	Description
Unit	Index of the physical layer (0-based)
pHWType	Table of hardware routines.

Additional information

This function is mandatory and it has to be called once for each used instance of the physical layer.

6.3.4.9 ONFI physical layer

This physical layer supports NAND flash devices that are compliant to ONFI specification. The organization of the NAND flash device such as page size and number of blocks is determined automatically by evaluating the parameters stored in the NAND flash device according to ONFI specification. The instances of this physical layer are allocated dynamically.

6.3.4.9.1 Compile time configuration

The ONFI physical layer can optionally be configured at compile time. Typically, this step can be omitted because reasonable default values are provided that work with most of the applications. The following table provides a summary of the configuration defines supported by this physical layer.

Define	Default value	Type	Description
FS_NAND_ONFI_DEVICE_LIST_DEFAULT	&FS_NAND_ONFI_DeviceListDefault	R	List of parallel NAND flash devices that can be handled by the physical layer.
FS_NAND_SUPPORT_EXT_ONFI_PARA	0	B	Specifies if the extended ONFI parameters have to be evaluated or not.

6.3.4.9.1.1 FS_NAND_ONFI_DEVICE_LIST_DEFAULT

FS_NAND_ONFI_DEVICE_LIST_DEFAULT specifies the list of parallel NAND flash devices that can be handled by the physical layer. It can be set to NULL in order to reduce the ROM usage if not all the devices included in FS_NAND_ONFI_DeviceListDefault have to be handled. In this case it is mandatory that the application configures a list of devices via FS_NAND_ONFI_SetDeviceList().

6.3.4.9.1.2 FS_NAND_SUPPORT_EXT_ONFI_PARA

FS_NAND_SUPPORT_EXT_ONFI_PARA can be used to enable the evaluation of extended ONFI parameters. By default the ONFI physical layer evaluates only the standard ONFI parameters. The extended ONFI parameters provide for example additional information about the bit error correction. Setting FS_NAND_SUPPORT_EXT_ONFI_PARA to 0 reduces the ROM usage.

6.3.4.9.2 Runtime configuration

The API functions listed in the following table can be used by the application to configure the behavior of the ONFI physical layer. The application can call them only at the file system initialization in FS_X_AddDevices().

Function	Description
FS_NAND_ONFI_SetHWType()	Configures the hardware access routines for a NAND physical layer of type FS_NAND_PHY_ONFI.
FS_NAND_ONFI_SetDeviceList()	Specifies the list of ONFI NAND flash devices that require special handling.

6.3.4.9.2.1 FS_NAND_ONFI_SetHWType()

Description

Configures the hardware access routines for a NAND physical layer of type `FS_NAND_PHY_ONFI`.

Prototype

```
void FS_NAND_ONFI_SetHWType(      U8          Unit,  
                               const FS_NAND_HW_TYPE * pHWType);
```

Parameters

Parameter	Description
<code>Unit</code>	Index of the physical layer instance (0-based)
<code>pHWType</code>	Type of the hardware layer to use. Cannot be <code>NULL</code> .

Additional information

This function is mandatory and has to be called once in `FS_X_AddDevices()` for every instance of a NAND physical layer of type `FS_NAND_PHY_ONFI`.

6.3.4.9.2.2 FS_NAND_ONFI_SetDeviceList()

Description

Specifies the list of ONFI NAND flash devices that require special handling.

Prototype

```
void FS_NAND_ONFI_SetDeviceList(      U8          Unit,
                                     const FS_NAND_ONFI_DEVICE_LIST * pDeviceList);
```

Parameters

Parameter	Description
<code>Unit</code>	Index of the physical layer (0-based)
<code>pDeviceList</code>	in List of ONFI NAND flash devices.

Additional information

NAND flash devices that do not require special handling such as devices without HW ECC are always enabled. The special handling is required for example to determine if the HW ECC of the NAND flash device can be enabled and disabled at runtime.

By default, only special handling for NAND flash devices from Micron and Macronix is enabled (`FS_NAND_ONFI_DeviceListDefault`). The correct operation of NAND flash device from a manufacturer not included in the configured list of devices is not guaranteed if the the NAND flash device requires special handling.

Permitted values for the `pDeviceList` parameter are:

Identifier	Description
<code>FS_NAND_ONFI_DeviceListAll</code>	Enables special handling for all supported NAND flash devices.
<code>FS_NAND_ONFI_DeviceListDefault</code>	Enables special handling of NAND flash devices from Micron and Macronix.
<code>FS_NAND_ONFI_DeviceListMacronix</code>	Enables special handling of Macronix parallel NAND flash devices.
<code>FS_NAND_ONFI_DeviceListMicron</code>	Enables special handling of Micron parallel NAND flash devices.
<code>FS_NAND_ONFI_DeviceListSkyHigh</code>	Enables special handling of SkyHigh parallel NAND flash devices.
<code>FS_NAND_ONFI_DeviceListGigaDevice</code>	Enables special handling of GigaDevice parallel NAND flash devices.
<code>FS_NAND_ONFI_DeviceListWinbond</code>	Enables special handling of Winbond parallel NAND flash devices.

6.3.4.10 Read-only ONFI physical layer

This physical layer is a variant of `FS_NAND_PHY_ONFI` with read-only access. `FS_NAND_PHY_ONFI_RO` provides the same functionality as `FS_NAND_PHY_ONFI` except that it cannot modify any data stored on the NAND flash device only to read it. The erase and write functions of `FS_NAND_PHY_ONFI_RO` do nothing and return an error to NAND driver when called.

`FS_NAND_PHY_ONFI_RO` uses the same runtime configuration functions and compile time configuration defines as `FS_NAND_PHY_ONFI`.

6.3.4.11 Small ONFI physical layer

This physical layer is a variant of `FS_NAND_PHY_ONFI` with reduced ROM usage. `FS_NAND_PHY_ONFI_Small` supports the same NAND flash devices as `FS_NAND_PHY_ONFI` but it does not provide support for the internal page copy operation and for the reading the ECC correction result. `FS_NAND_PHY_ONFI_Small` provides read as well as write access to NAND flash device.

`FS_NAND_PHY_ONFI_Small` uses the same runtime configuration functions and compile time configuration defines as `FS_NAND_PHY_ONFI`.

6.3.4.12 Quad-SPI physical layer

This physical layer supports NAND flash devices interfaced via quad or dual SPI. The organization of the NAND flash device such as page size and number of blocks is determined automatically by evaluating the parameters stored in the NAND flash device. The instances of this physical layer are allocated dynamically.

6.3.4.12.1 Compile time configuration

The QSPI physical layer can optionally be configured at compile time. Typically, this step can be omitted because reasonable default values are provided that work with most of the applications. The following table provides a summary of the configuration defines supported by this physical layer.

Define	Default value	Type	Description
FS_NAND_DEVICE_OPERATION_TIMEOUT	500	N	Timeout for a NAND flash device operation in milliseconds.
FS_NAND_RESET_TIME	2	N	Time to wait for the device to become ready after reset in milliseconds.
FS_NAND_SPI_DEVICE_LIST_DEFAULT	&FS_NAND_SPI_DeviceListAll	R ^{De}	List of serial NAND flash devices that can be handled by the physical layer.
FS_NAND_SUPPORT_COMPATIBILITY_MODE	0	N	Specifies the operating mode of the physical layer.
FS_NAND_SUPPORT_READ_CACHE	1	B	Specifies if the internal page register of the NAND flash should be used as read cache.

6.3.4.12.1.1 FS_NAND_DEVICE_OPERATION_TIMEOUT

`FS_NAND_DEVICE_OPERATION_TIMEOUT` specifies the maximum time in milliseconds the physical layer has to wait for a NAND flash operation to complete. This timeout is used for the read, write and as well as erase operations. This value has to be set according to the timings specified in the data sheet of the NAND flash device.

6.3.4.12.1.2 FS_NAND_RESET_TIME

`FS_NAND_RESET_TIME` specifies the time in milliseconds the physical layer waits for the NAND flash device to become ready after a reset command. This value has to be set according to the timings specified in the data sheet of the NAND flash device.

6.3.4.12.1.3 FS_NAND_SPI_DEVICE_LIST_DEFAULT

`FS_NAND_SPI_DEVICE_LIST_DEFAULT` specifies the list of serial NAND flash devices that can be handled by the physical layer. It can be set to `NULL` in order to reduce the ROM usage if not all the devices included in `FS_NAND_SPI_DeviceListDefault` have to be handled. In this case it is mandatory that the application configures a list of devices via `FS_NAND_QSPI_SetDeviceList()`.

6.3.4.12.1.4 FS_NAND_SUPPORT_COMPATIBILITY_MODE

emFile versions older than 4.06b wrongly stored the management data to a region of the spare area that was not protected by the HW ECC. This behavior affects only configurations that use the Micron MT29F1G01ABAFD NAND flash device. The correction of this behavior introduces a data compatibility that can be avoided by setting this define either to 1 or to 2. With `FS_NAND_SUPPORT_COMPATIBILITY_MODE` set to 1 the physical layer reads the management data from old location if at the new location no management data is present. With `FS_NAND_SUPPORT_COMPATIBILITY_MODE` set to 2 the physical layer updates the management data to old and new location in addition to trying to read it from both of these locations.

6.3.4.12.1.5 FS_NAND_SUPPORT_READ_CACHE

With `FS_NAND_SUPPORT_READ_CACHE` set to 1 the physical layer keeps track of the index of the last page read from the serial NAND flash device. If the same page is read again then the physical layer omits the operation that transfers the page data from the memory array to the internal page register of the serial NAND flash device. In this case only a data transfer from the internal page register to host is executed which helps improve the performance.

Note

This feature cannot be used if the NAND flash device is partitioned via `FS_NAND_UNI_SetBlockRange()` and the created partitions are accessed via the file system.

6.3.4.12.2 Runtime configuration

The API functions listed in the following table can be used by the application to configure the behavior of the QSPI physical layer. The application can call them only at the file system initialization in `FS_X_AddDevices()`.

Function	Description
<code>FS_NAND_QSPI_Allow2bitMode()</code>	Specifies if the physical layer can exchange data via 2 data lines.
<code>FS_NAND_QSPI_Allow4bitMode()</code>	Specifies if the physical layer can exchange data via 4 data lines.
<code>FS_NAND_QSPI_DisableReadCache()</code>	Deactivates the page read optimization.
<code>FS_NAND_QSPI_EnableReadCache()</code>	Activates the page read optimization.
<code>FS_NAND_QSPI_SetDeviceList()</code>	Specifies the list of enabled serial NAND flash devices.
<code>FS_NAND_QSPI_SetHWType()</code>	Configures the hardware access routines for a NAND physical layer of type <code>FS_NAND_PHY_QSPI</code> .

6.3.4.12.2.1 FS_NAND_QSPI_Allow2bitMode()

Description

Specifies if the physical layer can exchange data via 2 data lines.

Prototype

```
void FS_NAND_QSPI_Allow2bitMode(U8 Unit,  
                                U8 OnOff);
```

Parameters

Parameter	Description
<code>Unit</code>	Index of the physical layer (0-based)
<code>OnOff</code>	Activation status of the option. <ul style="list-style-type: none">• 0 Data is exchanged via 1 data line.• 1 Data is exchanged via 2 data lines.

Additional information

This function is optional. By default the data is exchanged via 1 data line (standard SPI mode).

6.3.4.12.2.2 FS_NAND_QSPI_Allow4bitMode()

Description

Specifies if the physical layer can exchange data via 4 data lines.

Prototype

```
void FS_NAND_QSPI_Allow4bitMode(U8 Unit,  
                                U8 OnOff);
```

Parameters

Parameter	Description
<code>Unit</code>	Index of the physical layer (0-based)
<code>OnOff</code>	Activation status of the option. <ul style="list-style-type: none">• 0 Data is exchanged via 1 data line or 2 data lines.• 1 Data is exchanged via 4 data lines.

Additional information

This function is optional. By default the data is exchanged via 1 data line (standard SPI mode).

6.3.4.12.2.3 FS_NAND_QSPI_DisableReadCache()

Description

Deactivates the page read optimization

Prototype

```
void FS_NAND_QSPI_DisableReadCache(U8 Unit);
```

Parameters

Parameter	Description
Unit	Index of the physical layer instance (0-based)

Additional information

This function is optional and is available only when the file system is build with `FS_NAND_SUPPORT_READ_CACHE` set to 1 which is the default. The optimization can be enabled at runtime via `FS_NAND_QSPI_EnableReadCache()`.

Refer to `FS_NAND_QSPI_EnableReadCache()` for more information about how the page read optimization works

6.3.4.12.2.4 FS_NAND_QSPI_EnableReadCache()

Description

Activates the page read optimization

Prototype

```
void FS_NAND_QSPI_EnableReadCache(U8 Unit);
```

Parameters

Parameter	Description
<code>Unit</code>	Index of the physical layer instance (0-based)

Additional information

This function is optional and is available only when the file system is build with `FS_NAND_SUPPORT_READ_CACHE` set to 1 which is the default. Activating the read cache can increase the overall performance of the NAND driver.

The optimization takes advantage of how the NAND flash device implements the read page operation. A NAND page read operation consists of two steps. In the first step, the page data is read from the memory array to internal page register of the NAND flash device. In the second step, the data is transferred from the internal page register of NAND flash device to MCU. With the optimization enabled the first step is skipped whenever possible.

The optimization is enabled by default and has to be disabled if two or more instances of the NAND driver are configured to access the same physical NAND flash device. At runtime, the optimization can be disabled via `FS_NAND_QSPI_DisableReadCache()`.

6.3.4.12.2.5 FS_NAND_QSPI_SetDeviceList()

Description

Specifies the list of enabled serial NAND flash devices.

Prototype

```
void FS_NAND_QSPI_SetDeviceList(      U8          Unit,
                                     const FS_NAND_SPI_DEVICE_LIST * pDeviceList);
```

Parameters

Parameter	Description
<code>Unit</code>	Index of the physical layer (0-based)
<code>pDeviceList</code>	<input type="checkbox"/> List of serial NAND flash devices.

Additional information

All supported serial NAND flash devices are enabled by default. Serial NAND flash devices that are not on the list are not recognized by the file system.

Permitted values for the `pDeviceList` parameter are:

Identifier	Description
<code>FS_NAND_SPI_DeviceListAll</code>	Enables handling of serial NAND flash devices from all manufacturers.
<code>FS_NAND_SPI_DeviceListAllianceMemory</code>	Enables handling of Alliance Memory serial NAND flash devices.
<code>FS_NAND_SPI_DeviceListDefault</code>	Enables handling of NAND flash devices from any other manufacturer.
<code>FS_NAND_SPI_DeviceListGigaDevice</code>	Enables handling of GigaDevice serial NAND flash devices.
<code>FS_NAND_SPI_DeviceListISSI</code>	Enables handling of ISSI serial NAND flash devices.
<code>FS_NAND_SPI_DeviceListMacronix</code>	Enables handling of Macronix serial NAND flash devices.
<code>FS_NAND_SPI_DeviceListMicron</code>	Enables handling of Micron serial NAND flash devices.
<code>FS_NAND_SPI_DeviceListToshiba</code>	Enables handling of Kioxia/Toshiba serial NAND flash devices.
<code>FS_NAND_SPI_DeviceListWinbond</code>	Enables handling of Winbond serial NAND flash devices.

6.3.4.12.2.6 FS_NAND_QSPI_SetHWType()

Description

Configures the hardware access routines for a NAND physical layer of type `FS_NAND_PHY_QSPI`.

Prototype

```
void FS_NAND_QSPI_SetHWType(          U8          Unit,  
                               const FS_NAND_HW_TYPE_QSPI * pHWType);
```

Parameters

Parameter	Description
<code>Unit</code>	Index of the physical layer instance (0-based)
<code>pHWType</code>	Type of the hardware layer to use. Cannot be <code>NULL</code> .

Additional information

This function is mandatory and has to be called once in `FS_X_AddDevices()` for every instance of a NAND physical layer of type `FS_NAND_PHY_QSPI`.

6.3.4.13 SPI physical layer

This physical layer supports NAND flash devices interfaced via standard SPI. The organization of the NAND flash device such as page size and number of blocks is determined automatically by evaluating the parameters stored in the NAND flash device. The instances of this physical layer are allocated dynamically.

6.3.4.13.1 Compile time configuration

The SPI physical layer can optionally be configured at compile time. Typically, this step can be omitted because reasonable default values are provided that work with most of the applications. The following table provides a summary of the configuration defines supported by this physical layer.

Define	Default value	Type	Description
FS_NAND_DEVICE_OPERATION_TIMEOUT	500	N	Timeout for a NAND flash device operation in milliseconds.
FS_NAND_RESET_TIME	2	N	Time to wait for the device to become ready after reset in milliseconds.
FS_NAND_SPI_DEVICE_LIST_DEFAULT	&FS_NAND_SPI_DeviceListAll	R ^{De-}	List of serial NAND flash devices that can be handled by the physical layer.
FS_NAND_SUPPORT_COMPATIBILITY_MODE	0	N	Specifies the operating mode of the physical layer.
FS_NAND_SUPPORT_READ_CACHE	1	B	Specifies if the internal page register of the NAND flash should be used as read cache.

6.3.4.13.1.1 FS_NAND_DEVICE_OPERATION_TIMEOUT

`FS_NAND_DEVICE_OPERATION_TIMEOUT` specifies the maximum time in milliseconds the physical layer has to wait for a NAND flash operation to complete. This value has to be set according to the timings specified in the data sheet of the NAND flash device.

6.3.4.13.1.2 FS_NAND_RESET_TIME

`FS_NAND_RESET_TIME` specifies the time in milliseconds the physical layer waits for the NAND flash device to become ready after a reset command. This value has to be set according to the timings specified in the data sheet of the NAND flash device.

6.3.4.13.1.3 FS_NAND_SPI_DEVICE_LIST_DEFAULT

`FS_NAND_SPI_DEVICE_LIST_DEFAULT` specifies the list of serial NAND flash devices that can be handled by the physical layer. It can be set to `NULL` in order to reduce the ROM usage if not all the devices included in `FS_NAND_SPI_DeviceListDefault` have to be handled. In this case it is mandatory that the application configures a list of devices via `FS_NAND_SPI_SetDeviceList()`.

6.3.4.13.1.4 FS_NAND_SUPPORT_COMPATIBILITY_MODE

emFile versions older than 4.06b wrongly stored the management data to a region of the spare area that was not protected by the HW ECC. This behavior affects only configurations that use the Micron MT29F1G01ABAFD NAND flash device. The correction of this behavior introduces a data compatibility that can be avoided by setting this define either to 1 or to 2. With `FS_NAND_SUPPORT_COMPATIBILITY_MODE` set to 1 the physical layer reads the management data from old location if at the new location no management data is present. With `FS_NAND_SUPPORT_COMPATIBILITY_MODE` set to 2 the physical layer updates the management data to old and new location in addition to trying to read it from both of these locations.

6.3.4.13.1.5 FS_NAND_SUPPORT_READ_CACHE

With `FS_NAND_SUPPORT_READ_CACHE` set to 1 the physical layer keeps track of the index of the last page read from the serial NAND flash device. If the same page is read again then the physical layer omits the operation that transfers the page data from the memory array to the internal page register of the serial NAND flash device. In this case only a data transfer from the internal page register to host is executed which helps improve the performance.

Note

This feature cannot be used if the NAND flash device is partitioned via `FS_NAND_UNI_SetBlockRange()` and the created partitions are accessed via the file system.

6.3.4.13.2 Runtime configuration

The API functions listed in the following table can be used by the application to configure the behavior of the SPI physical layer. The application can call them only at the file system initialization in `FS_X_AddDevices()`.

Function	Description
<code>FS_NAND_SPI_DisableReadCache()</code>	Deactivates the page read optimization.
<code>FS_NAND_SPI_EnableReadCache()</code>	Activates the page read optimization.
<code>FS_NAND_SPI_SetDeviceList()</code>	Specifies the list of enabled serial NAND flash devices.
<code>FS_NAND_SPI_SetHWType()</code>	Configures the hardware access routines for a NAND physical layer of type <code>FS_NAND_PHY_SPI</code> .

6.3.4.13.2.1 FS_NAND_SPI_DisableReadCache()

Description

Deactivates the page read optimization

Prototype

```
void FS_NAND_SPI_DisableReadCache(U8 Unit);
```

Parameters

Parameter	Description
Unit	Index of the physical layer instance (0-based)

Additional information

This function is optional and is available only when the file system is build with `FS_NAND_SUPPORT_READ_CACHE` set to 1 which is the default. The optimization can be enabled at runtime via `FS_NAND_SPI_EnableReadCache()`.

Refer to `FS_NAND_SPI_EnableReadCache()` for more information about how the page read optimization works

6.3.4.13.2.2 FS_NAND_SPI_EnableReadCache()

Description

Activates the page read optimization

Prototype

```
void FS_NAND_SPI_EnableReadCache(U8 Unit);
```

Parameters

Parameter	Description
Unit	Index of the physical layer instance (0-based)

Additional information

This function is optional and is available only when the file system is build with `FS_NAND_SUPPORT_READ_CACHE` set to 1 which is the default. Activating the read cache can increase the overall performance of the NAND driver.

The optimization takes advantage of how the NAND flash device implements the read page operation. A NAND page read operation consists of two steps. In the first step, the page data is read from the memory array to internal page register of the NAND flash device. In the second step, the data is transferred from the internal page register of NAND flash device to MCU. With the optimization enabled the first step is skipped whenever possible.

The optimization is enabled by default and has to be disabled if two or more instances of the NAND driver are configured to access the same physical NAND flash device. At runtime, the optimization can be disabled via `FS_NAND_SPI_DisableReadCache()`.

6.3.4.13.2.3 FS_NAND_SPI_SetDeviceList()

Description

Specifies the list of enabled serial NAND flash devices.

Prototype

```
void FS_NAND_SPI_SetDeviceList(      U8          Unit,
                                   const FS_NAND_SPI_DEVICE_LIST * pDeviceList);
```

Parameters

Parameter	Description
<code>Unit</code>	Index of the physical layer (0-based)
<code>pDeviceList</code>	in List of serial NAND flash devices.

Additional information

All supported serial NAND flash devices are enabled by default. Serial NAND flash devices that are not on the list are not recognized by the file system.

Permitted values for the `pDeviceList` parameter are:

Identifier	Description
<code>FS_NAND_SPI_DeviceListAll</code>	Enables handling of serial NAND flash devices from all manufacturers.
<code>FS_NAND_SPI_DeviceListDefault</code>	Enables handling of NAND flash devices from any other manufacturer.
<code>FS_NAND_SPI_DeviceListISSI</code>	Enables handling of ISSI serial NAND flash devices.
<code>FS_NAND_SPI_DeviceListMacronix</code>	Enables handling of Macronix serial NAND flash devices.
<code>FS_NAND_SPI_DeviceListMicron</code>	Enables handling of Micron serial NAND flash devices.
<code>FS_NAND_SPI_DeviceListToshiba</code>	Enables handling of Kioxia/Toshiba serial NAND flash devices.
<code>FS_NAND_SPI_DeviceListWinbond</code>	Enables handling of Winbond serial NAND flash devices.

6.3.4.13.2.4 FS_NAND_SPI_SetHWType()

Description

Configures the hardware access routines for a NAND physical layer of type `FS_NAND_PHY_SPI`.

Prototype

```
void FS_NAND_SPI_SetHWType(          U8          Unit,
                               const FS_NAND_HW_TYPE_SPI * pHWType);
```

Parameters

Parameter	Description
<code>Unit</code>	Index of the physical layer instance (0-based)
<code>pHWType</code>	Type of the hardware layer to use. Cannot be <code>NULL</code> .

Additional information

This function is mandatory and has to be called once in `FS_X_AddDevices()` for every instance of a NAND physical layer of type `FS_NAND_PHY_SPI`.

6.3.4.14 8/16-bit data bus physical layer

This physical layer supports all the NAND flash devices supported by the following NAND physical layers:

- FS_NAND_PHY_512x8
- FS_NAND_PHY_2048x8
- FS_NAND_PHY_2048x16
- FS_NAND_PHY_4096x8
- FS_NAND_PHY_ONFI

6.3.4.14.1 Compile time configuration

The 16/8-bit data bus physical layer can optionally be configured at compile time. Typically, this step can be omitted because reasonable default values are provided that work with most of the applications. The following table provides a summary of the configuration defines supported by this physical layer.

Define	Default value	Type	Description
FS_NAND_SUPPORT_AUTO_DETECTION	1	B	Specifies if the parameters of the NAND flash device have to be automatically detected or not.

6.3.4.14.1.1 FS_NAND_SUPPORT_AUTO_DETECTION

By default, the 8-bit data bus physical layer tries to automatically detect the parameters of the NAND flash device such as the number of blocks and the number of pages in the block by evaluating the value returned as response to the READ ID (0x90) command. This behavior can be disabled by building the physical layer with FS_NAND_SUPPORT_AUTO_DETECTION set to 0. In this case, the application must call FS_NAND_x_Configure() in FS_X_AddDevices() to specify the parameters of the NAND flash device.

6.3.4.14.2 Runtime configuration

The API functions listed in the following table can be used by the application to configure the behavior of the 16/8-bit data bus physical layer. The application can call them only at the file system initialization in FS_X_AddDevices().

Function	Description
FS_NAND_x_Configure()	Configures the parameters of the NAND flash device for a NAND physical layer of type FS_NAND_PHY_x.
FS_NAND_x_SetHWType()	Configures the hardware access routines for a NAND physical layer of type FS_NAND_PHY_x.

6.3.4.14.2.1 FS_NAND_x_Configure()

Description

Configures the parameters of the NAND flash device for a NAND physical layer of type FS_NAND_PHY_x.

Prototype

```
void FS_NAND_x_Configure(U8          Unit,
                        unsigned NumBlocks,
                        unsigned PagesPerBlock,
                        unsigned BytesPerPage,
                        unsigned BytesPerSpareArea,
                        unsigned DataBusWidth);
```

Parameters

Parameter	Description
Unit	Index of the physical layer instance (0-based)
NumBlocks	Total number of blocks in the NAND flash device.
PagesPerBlock	Total number of pages in a NAND block.
BytesPerPage	Number of bytes in a page without the spare area.
BytesPerSpareArea	Number of bytes in the spare area of a NAND page.
DataBusWidth	Number of data lines used for data exchange.

Additional information

This function is mandatory only when the file system is built with FS_NAND_SUPPORT_AUTO_DETECTION set to 0 which is not the default. FS_NAND_x_Configure() has to be called once in FS_X_AddDevices() for each instance of the FS_NAND_PHY_x physical layer. FS_NAND_x_Configure() is not available if FS_NAND_SUPPORT_AUTO_DETECTION is set to 0.

By default, the FS_NAND_PHY_x physical layer identifies the parameters of the NAND flash device by evaluating the first and second byte of the reply returned by the NAND flash device to the READ ID (0x90) command. The identification operation is disabled if FS_NAND_SUPPORT_AUTO_DETECTION set to 0 and the application must specify the NAND flash parameters via this function.

6.3.4.14.2.2 FS_NAND_x_SetHWType()

Description

Configures the hardware access routines for a NAND physical layer of type FS_NAND_PHY_x.

Prototype

```
void FS_NAND_x_SetHWType(      U8          Unit,  
                           const FS_NAND_HW_TYPE * pHWType);
```

Parameters

Parameter	Description
Unit	Index of the physical layer instance (0-based)
pHWType	Type of the hardware layer to use. Cannot be NULL.

Additional information

This function is mandatory and has to be called once in FS_X_AddDevices() for every instance of a NAND physical layer of type FS_NAND_PHY_x.

6.3.4.15 8-bit data bus physical layer

This physical layer supports all the NAND flash devices supported by the following NAND physical layers:

- FS_NAND_PHY_512x8
- FS_NAND_PHY_2048x8
- FS_NAND_PHY_4096x8
- FS_NAND_PHY_ONFI

6.3.4.15.1 Compile time configuration

The 8-bit data bus physical layer can optionally be configured at compile time. Typically, this step can be omitted because reasonable default values are provided that work with most of the applications. The following table provides a summary of the configuration defines supported by this physical layer.

Define	Default value	Type	Description
FS_NAND_SUPPORT_AUTO_DETECTION	1	B	Specifies if the parameters of the NAND flash device have to be automatically detected or not.

6.3.4.15.1.1 FS_NAND_SUPPORT_AUTO_DETECTION

By default, the 8-bit data bus physical layer tries to automatically detect the parameters of the NAND flash device such as the number of blocks and the number of pages in the block by evaluating the value returned as response to the READ ID (0x90) command. This behavior can be disabled by building the physical layer with FS_NAND_SUPPORT_AUTO_DETECTION set to 0. In this case, the application must call FS_NAND_x8_Configure() in FS_X_AddDevices() to specify the parameters of the NAND flash device.

6.3.4.15.2 Runtime configuration

The API functions listed in the following table can be used by the application to configure the behavior of the 8-bit data bus physical layer. The application can call them only at the file system initialization in FS_X_AddDevices().

Function	Description
FS_NAND_x8_Configure()	Configures the parameters of the NAND flash device for a NAND physical layer of type FS_NAND_PHY_x8.
FS_NAND_x8_SetHWType()	Configures the hardware access routines for a NAND physical layer of type FS_NAND_PHY_x8.

6.3.4.15.2.1 FS_NAND_x8_Configure()

Description

Configures the parameters of the NAND flash device for a NAND physical layer of type `FS_NAND_PHY_x8`.

Prototype

```
void FS_NAND_x8_Configure(U8          Unit,
                          unsigned NumBlocks,
                          unsigned PagesPerBlock,
                          unsigned BytesPerPage,
                          unsigned BytesPerSpareArea);
```

Parameters

Parameter	Description
<code>Unit</code>	Index of the physical layer instance (0-based)
<code>NumBlocks</code>	Total number of blocks in the NAND flash device.
<code>PagesPerBlock</code>	Total number of pages in a NAND block.
<code>BytesPerPage</code>	Number of bytes in a page without the spare area.
<code>BytesPerSpareArea</code>	Number of bytes in the spare area of a NAND page.

Additional information

This function is mandatory only when the file system is built with `FS_NAND_SUPPORT_AUTO_DETECTION` set to 0 which is not the default. `FS_NAND_x_Configure()` has to be called once in `FS_X_AddDevices()` for each instance of the `FS_NAND_PHY_x8` physical layer. `FS_NAND_x_Configure()` is not available if `FS_NAND_SUPPORT_AUTO_DETECTION` is set to 0.

By default, the `FS_NAND_PHY_x8` physical layer identifies the parameters of the NAND flash device by evaluating the first and second byte of the reply returned by the NAND flash device to the `READ ID (0x90)` command. The identification operation is disabled if `FS_NAND_SUPPORT_AUTO_DETECTION` set to 0 and the application must specify the NAND flash parameters via this function.

6.3.4.15.2 FS_NAND_x8_SetHWType()

Description

Configures the hardware access routines for a NAND physical layer of type `FS_NAND_PHY_x8`.

Prototype

```
void FS_NAND_x8_SetHWType(      U8          Unit,
                               const FS_NAND_HW_TYPE * pHWType);
```

Parameters

Parameter	Description
<code>Unit</code>	Index of the physical layer instance (0-based)
<code>pHWType</code>	Type of the hardware layer to use. Cannot be <code>NULL</code> .

Additional information

This function has to be called once in `FS_X_AddDevices()` for every instance of a NAND physical layer of type `FS_NAND_PHY_x8`.

6.3.4.16 Physical layer API

The physical layers that come with emFile provide support most of the popular NAND flash device and target MCU types. Therefore, there is no need to modify any of the provided NAND physical layers. Typically, only the NAND hardware layer has to be adapted to a specific target hardware. However, when none of the provided NAND physical layers are compatible with the target hardware a new NAND physical layer implementation is required. This section provides information about the API of the NAND physical layer that helps to create a new physical layer from scratch or to modify an existing one.

The API of the physical layer is implemented as a structure of type `FS_NAND_PHY_TYPE` that contains pointers to functions. The following sections describe these functions in detail together with the data structure passed to these functions as parameters.

6.3.4.16.1 FS_NAND_PHY_TYPE

Description

NAND physical layer API.

Type definition

```
typedef struct {
    FS_NAND_PHY_TYPE_ERASE_BLOCK          * pfEraseBlock;
    FS_NAND_PHY_TYPE_INIT_GET_DEVICE_INFO * pfInitGetDeviceInfo;
    FS_NAND_PHY_TYPE_IS_WP                * pfIsWP;
    FS_NAND_PHY_TYPE_READ                 * pfRead;
    FS_NAND_PHY_TYPE_READ_EX              * pfReadEx;
    FS_NAND_PHY_TYPE_WRITE                 * pfWrite;
    FS_NAND_PHY_TYPE_WRITE_EX              * pfWriteEx;
    FS_NAND_PHY_TYPE_ENABLE_ECC           * pfEnableECC;
    FS_NAND_PHY_TYPE_DISABLE_ECC          * pfDisableECC;
    FS_NAND_PHY_TYPE_CONFIGURE_ECC        * pfConfigureECC;
    FS_NAND_PHY_TYPE_COPY_PAGE            * pfCopyPage;
    FS_NAND_PHY_TYPE_GET_ECC_RESULT        * pfGetECCResult;
    FS_NAND_PHY_TYPE_DEINIT               * pfDeInit;
    FS_NAND_PHY_TYPE_SET_RAW_MODE          * pfSetRawMode;
} FS_NAND_PHY_TYPE;
```

Structure members

Member	Description
pfEraseBlock	Erases a NAND block.
pfInitGetDeviceInfo	Initializes the physical layer.
pfIsWP	Checks the write protection status of NAND flash device.
pfRead	Reads data from a NAND page.
pfReadEx	Reads data from a NAND page.
pfWrite	Writes data to a NAND page.
pfWriteEx	Writes data to a NAND page.
pfEnableECC	Enables the hardware ECC.
pfDisableECC	Disables the hardware ECC.
pfConfigureECC	Configures the hardware ECC.
pfCopyPage	Copies a NAND page.
pfGetECCResult	Returns the result of bit correction via ECC.
pfDeInit	Frees allocated resources.
pfSetRawMode	Enables or disables the raw operation mode.

6.3.4.16.2 FS_NAND_PHY_TYPE_ERASE_BLOCK

Description

Erases a NAND block.

Type definition

```
typedef int FS_NAND_PHY_TYPE_ERASE_BLOCK(U8 Unit,
                                          U32 PageIndex);
```

Parameters

Parameter	Description
Unit	Index of the NAND physical layer instance (0-based)
PageIndex	Index of the first page in the NAND block to be erased (0-based)

Return value

= 0 OK, the NAND block has been erased.
 ≠ 0 An error occurred.

Additional information

This function is a member of the NAND physical layer API. It is mandatory to be implemented by all the NAND physical layers. It is called by the NAND driver to set to 1 all the bits of a NAND block. A NAND block is the smallest erasable unit of a NAND flash device.

The index of the actual NAND block to be erased depends on the number of pages stored in a NAND block. For example if the NAND block contains 64 pages, then the [PageIndex](#) parameter passed by the NAND driver to the function has to be interpreted as follows:

- 0 - NAND block 0
- 64 - NAND block 1
- 128 - NAND block 2
- etc.

6.3.4.16.3 FS_NAND_PHY_TYPE_INIT_GET_DEVICE_INFO

Description

Initializes the physical layer.

Type definition

```
typedef int FS_NAND_PHY_TYPE_INIT_GET_DEVICE_INFO(U8 Unit,
FS_NAND_DEVICE_INFO * pDevInfo);
```

Parameters

Parameter	Description
<code>Unit</code>	Index of the NAND physical layer instance (0-based)
<code>pDevInfo</code>	<code>out</code> Information about the NAND flash device.

Return value

= 0 OK, physical layer has been initialized.
 ≠ 0 An error occurred.

Additional information

This function is a member of the NAND physical layer API. It is mandatory to be implemented by all the NAND physical layers. It is the first function of the physical layer API that is called by the NAND driver when the NAND flash device is mounted.

This function initializes hardware layer, resets and tries to identify the NAND flash device. If the NAND flash device can be handled, the `pDevInfo` is filled with information about the organization and the ECC requirements of the NAND flash device.

6.3.4.16.4 FS_NAND_PHY_TYPE_IS_WP

Description

Checks if the NAND flash device is write protected.

Type definition

```
typedef int FS_NAND_PHY_TYPE_IS_WP(U8 Unit);
```

Parameters

Parameter	Description
Unit	Index of the NAND physical layer instance (0-based)

Return value

- = 0 Data stored on the NAND flash device can be modified.
- ≠ 0 Data stored on the NAND flash device cannot be modified.

Additional information

This function is a member of the NAND physical layer API. It is mandatory to be implemented by all the NAND physical layers.

The write protection status is checked by evaluating the bit 7 of the NAND status register. Typical reason for write protection is that either the supply voltage is too low or the /WP-pin is connected to ground.

6.3.4.16.5 FS_NAND_PHY_TYPE_READ

Description

Reads data from a NAND page.

Type definition

```
typedef int FS_NAND_PHY_TYPE_READ(U8      Unit,
                                   U32      PageIndex,
                                   void     * pData,
                                   unsigned  Off,
                                   unsigned  NumBytes);
```

Parameters

Parameter	Description
<code>Unit</code>	Index of the NAND physical layer instance (0-based)
<code>PageIndex</code>	Index of the NAND page to read from (0-based).
<code>pData</code>	<code>out</code> Data read from NAND page.
<code>Off</code>	Byte offset to read from.
<code>NumBytes</code>	Number of bytes to be read.

Return value

= 0 OK, data read.
 ≠ 0 An error occurred.

Additional information

This function is a member of the NAND physical layer API. It has to be implemented by all the NAND physical layers. The NAND driver uses `FS_NAND_PHY_TYPE_READ` to read data from the main as well as from the spare area of a page.

6.3.4.16.6 FS_NAND_PHY_TYPE_READ_EX

Description

Reads data from two different locations of a NAND page.

Type definition

```
typedef int FS_NAND_PHY_TYPE_READ_EX(U8      Unit,
                                     U32      PageIndex,
                                     void *  pData0,
                                     unsigned Off0,
                                     unsigned NumBytes0,
                                     void *  pData1,
                                     unsigned Off1,
                                     unsigned NumBytes1);
```

Parameters

Parameter	Description
<code>Unit</code>	Index of the NAND physical layer instance (0-based)
<code>PageIndex</code>	Index of the NAND page to read from (0-based).
<code>pData0</code>	out Data read from <code>Off0</code> of the NAND page.
<code>Off0</code>	Byte offset to read from for <code>pData0</code> .
<code>NumBytes0</code>	Number of bytes to be read.
<code>pData1</code>	out Data read from <code>Off1</code> of a NAND page.
<code>Off1</code>	Byte offset to read from for <code>pData1</code> .
<code>NumBytes1</code>	Number of bytes to be read from <code>Off1</code> .

Return value

= 0 OK, data read.
 ≠ 0 An error occurred.

Additional information

This function is a member of the NAND physical layer API. It has to be implemented by all the NAND physical layers. `FS_NAND_PHY_TYPE_READ_EX` is typically used by the NAND driver to read the data from main and spare area of a page at the same time.

It is guaranteed that `Off0` is always smaller than `Off1` and that the region defined by `Off0` and `NumBytes0` does not overlap the region defined by `Off1` and `NumBytes1`.

6.3.4.16.7 FS_NAND_PHY_TYPE_WRITE

Description

Writes data to a NAND page.

Type definition

```
typedef int FS_NAND_PHY_TYPE_WRITE(
    U8      Unit,
    U32     PageIndex,
    const void * pData,
    unsigned Off,
    unsigned NumBytes);
```

Parameters

Parameter	Description
<code>Unit</code>	Index of the NAND physical layer instance (0-based)
<code>PageIndex</code>	Index of the NAND page to write to (0-based).
<code>pData</code>	in Data to be written to the NAND page.
<code>Off</code>	Byte offset to write to.
<code>NumBytes</code>	Number of bytes to be written.

Return value

= 0 OK, data written.
 ≠ 0 An error occurred.

Additional information

This function is a member of the NAND physical layer API. It has to be implemented only by a NAND physical layer that works with the SLC1 NAND driver. The Universal NAND driver does not call this function. `FS_NAND_PHY_TYPE_WRITE` is used by the SLC1 NAND driver to write data to the main as well as to the spare area of a page.

6.3.4.16.8 FS_NAND_PHY_TYPE_WRITE_EX

Description

Writes data to two different locations of a NAND page.

Type definition

```
typedef int FS_NAND_PHY_TYPE_WRITE_EX(
    U8      Unit,
    U32     PageIndex,
    const void * pData0,
    unsigned Off0,
    unsigned NumBytes0,
    const void * pData1,
    unsigned Off1,
    unsigned NumBytes1);
```

Parameters

Parameter	Description
<code>Unit</code>	Index of the NAND physical layer instance (0-based)
<code>PageIndex</code>	Index of the NAND page to write to (0-based).
<code>pData0</code>	in Data to be written to the NAND page at <code>Off0</code> .
<code>Off0</code>	Byte offset to write to for <code>pData0</code> .
<code>NumBytes0</code>	Number of bytes to be written at <code>Off0</code> .
<code>pData1</code>	in Data to be written to the NAND page at <code>Off1</code> .
<code>Off1</code>	Byte offset to write to for <code>pData1</code> .
<code>NumBytes1</code>	Number of bytes to be written at <code>Off1</code> .

Return value

= 0 OK, data written.
 ≠ 0 An error occurred.

Additional information

This function is a member of the NAND physical layer API. It has to be implemented by all the NAND physical layers. The NAND driver uses `FS_NAND_PHY_TYPE_WRITE_EX` to write data to the main and spare area of a page at the same time.

It is guaranteed that `Off0` is always smaller than `Off1` and that the region defined by `Off0` and `NumBytes0` does not overlap the region defined by `Off1` and `NumBytes1`.

6.3.4.16.9 FS_NAND_PHY_TYPE_ENABLE_ECC

Description

Enables the hardware ECC.

Type definition

```
typedef int FS_NAND_PHY_TYPE_ENABLE_ECC(U8 Unit);
```

Parameters

Parameter	Description
<code>Unit</code>	Index of the NAND physical layer instance (0-based)

Return value

= 0 OK, hardware ECC activated.
 ≠ 0 An error occurred.

Additional information

This function is a member of the NAND physical layer API. It has to be implemented by the NAND physical layers that provide hardware support for bit error correction either on MCU via a dedicated NAND flash controller or via on-die ECC of the NAND flash device. `FS_NAND_PHY_TYPE_ENABLE_ECC` is called only by the Universal NAND driver.

After the call to this function the Universal NAND driver expects that `FS_NAND_PHY_TYPE_READ` and `FS_NAND_PHY_TYPE_READ_EX` return corrected data that is without bit errors. In addition, the Universal NAND driver expects that `FS_NAND_PHY_TYPE_WRITE` and `FS_NAND_PHY_TYPE_WRITE_EX` calculate and store the ECC to NAND flash device.

6.3.4.16.10 FS_NAND_PHY_TYPE_DISABLE_ECC

Description

Deactivates the hardware ECC.

Type definition

```
typedef int FS_NAND_PHY_TYPE_DISABLE_ECC(U8 Unit);
```

Parameters

Parameter	Description
<code>Unit</code>	Index of the NAND physical layer instance (0-based)

Return value

= 0 OK, hardware ECC deactivated.
 ≠ 0 An error occurred.

Additional information

This function is a member of the NAND physical layer API. It has to be implemented by the NAND physical layers that provide hardware support for bit error correction. `FS_NAND_PHY_TYPE_DISABLE_ECC` is called only by the Universal NAND driver.

After the call to this function the Universal NAND driver expects that `FS_NAND_PHY_TYPE_READ` and `FS_NAND_PHY_TYPE_READ_EX` return data that might contain bit errors. In addition, the Universal NAND driver expects that `FS_NAND_PHY_TYPE_WRITE` and `FS_NAND_PHY_TYPE_WRITE_EX` store the data without calculating the ECC.

6.3.4.16.11 FS_NAND_PHY_TYPE_CONFIGURE_ECC

Description

Configures the hardware ECC.

Type definition

```
typedef int FS_NAND_PHY_TYPE_CONFIGURE_ECC(U8 Unit,
                                           U8 NumBitsCorrectable,
                                           U16 BytesPerECCBlock);
```

Parameters

Parameter	Description
<code>Unit</code>	Index of the NAND physical layer instance (0-based)
<code>NumBitsCorrectable</code>	Maximum number of bit errors the hardware ECC has to be able to correct.
<code>BytesPerECCBlock</code>	Number of consecutive data bytes protected by a single ECC.

Return value

= 0 OK, hardware ECC configured.
 ≠ 0 An error occurred.

Additional information

This function is a member of the NAND physical layer API. It has to be implemented by the NAND physical layers that provide hardware support for bit error correction with configurable ECC strength. `FS_NAND_PHY_TYPE_CONFIGURE_ECC` is called only by the Universal NAND driver.

6.3.4.16.12 FS_NAND_PHY_TYPE_COPY_PAGE

Description

Copies the contents of an entire page to another page.

Type definition

```
typedef int FS_NAND_PHY_TYPE_COPY_PAGE(U8 Unit,
                                       U32 PageIndexSrc,
                                       U32 PageIndexDest);
```

Parameters

Parameter	Description
<code>Unit</code>	Index of the NAND physical layer instance (0-based)
<code>PageIndexSrc</code>	Index of the page to copy from.
<code>PageIndexDest</code>	Index of the page to copy to.

Return value

= 0 OK, page copied.
 ≠ 0 An error occurred or operation not supported.

Additional information

This function is a member of the NAND physical layer API. It may be implemented by the NAND physical layers that can provide a faster method of copying the contents of a page than by first reading the source page contents to MCU and then by writing the contents to the destination page. One such method is the internal page copy operation supported by some NAND flash device. `FS_NAND_PHY_TYPE_COPY_PAGE` is called only by the Universal NAND driver.

6.3.4.16.13 FS_NAND_PHY_TYPE_GET_ECC_RESULT

Description

Returns the error correction status of the last read page.

Type definition

```
typedef int FS_NAND_PHY_TYPE_GET_ECC_RESULT(U8 Unit,
                                             FS_NAND_ECC_RESULT * pResult);
```

Parameters

Parameter	Description
<code>Unit</code>	Index of the NAND physical layer instance (0-based)
<code>pResult</code>	<code>out</code> Information about the correction status.

Return value

- = 0 OK, information returned.
- ≠ 0 An error occurred or operation not supported.

Additional information

This function is a member of the NAND physical layer API. It may be implemented by the NAND physical layers that can provide information about the status of the bit correction operation and about the number of bit errors corrected. `FS_NAND_PHY_TYPE_GET_ECC_RESULT` is called only by the Universal NAND driver.

The information returned by `FS_NAND_PHY_TYPE_GET_ECC_RESULT` is used by the Universal NAND driver to decide when a NAND block has to be relocated in order to prevent bit correction errors. A bit correction error occurs when the number of bit errors is greater than the number of bit errors the ECC is able to correct. Typically, a bit correction error causes a data loss.

6.3.4.16.14 FS_NAND_PHY_TYPE_DEINIT

Description

Releases the allocated resources.

Type definition

```
typedef void FS_NAND_PHY_TYPE_DEINIT(U8 Unit);
```

Parameters

Parameter	Description
<code>Unit</code>	Index of the NAND physical layer instance (0-based)

Additional information

This function is a member of the NAND physical layer API. It has to be implemented by the NAND physical layers that allocate resources dynamically during the initialization such as memory for the instance.

The NAND driver calls this function when the file system is unmounted.

6.3.4.16.15 FS_NAND_PHY_TYPE_SET_RAW_MODE

Description

Enables or disables the data translation.

Type definition

```
typedef int FS_NAND_PHY_TYPE_SET_RAW_MODE(U8 Unit,
                                           U8 OnOff);
```

Parameters

Parameter	Description
<code>Unit</code>	Index of the NAND physical layer instance (0-based)
<code>OnOff</code>	Activation status of the feature.

Return value

= 0 OK, status changed.
 ≠ 0 An error occurred or operation not supported.

Additional information

This function is a member of the NAND physical layer API. It may be implemented by the NAND physical layers that store the data to NAND flash device using a different layout than the NAND driver. `FS_NAND_PHY_TYPE_SET_RAW_MODE` is not called by the NAND driver during the normal operation. It is called only by specific functions of the Universal NAND driver such as `FS_NAND_UNI_WritePageRaw()` and `FS_NAND_UNI_ReadPageRaw()`.

6.3.4.16.16 FS_NAND_DEVICE_INFO

Description

Information about the NAND flash device.

Type definition

```
typedef struct {
    U8      BPP_Shift;
    U8      PPB_Shift;
    U16     NumBlocks;
    U16     BytesPerSpareArea;
    FS_NAND_ECC_INFO ECC_Info;
    U8      DataBusWidth;
    U8      BadBlockMarkingType;
    U8      PPO_Shift;
} FS_NAND_DEVICE_INFO;
```

Structure members

Member	Description
BPP_Shift	Bytes per page as a power of two value.
PPB_Shift	Pages per block as a power of two value.
NumBlocks	Total number of blocks in the NAND flash device.
BytesPerSpareArea	Number of bytes in the spare area.
ECC_Info	Information about the ECC capability required by the NAND flash device.
DataBusWidth	Number of lines used for exchanging the data with the NAND flash device.
BadBlockMarkingType	Specifies how the blocks are marked as defective.
PPO_Shift	Number of operations performed in parallel by the NAND physical layer.

Additional information

The initialization function of the physical layer `FS_NAND_PHY_TYPE_INIT_GET_DEVICE_INFO` uses this structure to return information about the NAND flash device to the NAND driver.

Typical values for [BPP_Shift](#) are 9 and 11 for NAND flash devices with a page size (without the spare area) of 512 and 2048 bytes respectively.

[BytesPerSpareArea](#) is typically 1/32 of the page size ($2^{\text{BPP_Shift}}$) but some NAND flash devices have a spare area larger than this. For example Micron MT29F8G08ABABA has a spare area of 224 bytes for a page size of 4096 bytes.

[DataBusWidth](#) can take the following values:

- 0 - unknown
- 1 - SPI
- 8 - parallel 8-bit
- 16 - parallel 16-bit

Refer to *Bad block marking types* on page 579 for a list of permitted values for [BadBlockMarkingType](#).

[PPO_Shift](#) (Planes Per Operation) has to be specified as a power of two value. Most of the NAND physical layers set this value to 0 to indicate that they do not support parallel operations. `FS_NAND_PHY_2048x8_TwoPlane` sets this value to 1 because it can read and write two NAND pages at once and it can erase two NAND blocks at once. This information is used by the Universal NAND driver to correctly identify and mark defective blocks.

6.3.4.16.17 FS_NAND_ECC_INFO

Description

Information about the ECC used to protect data stored on the NAND flash.

Type definition

```
typedef struct {
    U8  NumBitsCorrectable;
    U8  ldBytesPerBlock;
    U8  HasHW_ECC;
    U8  IsHW_ECCEnabledPerm;
} FS_NAND_ECC_INFO;
```

Structure members

Member	Description
NumBitsCorrectable	Maximum number of bit errors the ECC should be able to correct.
ldBytesPerBlock	Number of bytes the ECC should protect as power of 2 exponent.
HasHW_ECC	Set to 1 if the NAND flash device has internal HW ECC.
IsHW_ECCEnabledPerm	Set to 1 if the internal HW ECC of the NAND flash device cannot be disabled.

Additional information

The value of [IsHW_ECCEnabledPerm](#) is valid only if the value of [HasHW_ECC](#) is different than 0.

[ldBytesPerBlock](#) is a power of 2 value. If [HasHW_ECC](#) is different than 0 [ldBytesPerBlock](#) represents the number of bytes in the main and spare area of a NAND page the internal HW ECC is able to protect against bit errors. More than one ECC is used to protect the data in a NAND page if the size of the NAND page is larger than [ldBytesPerBlock](#). [ldBytesPerBlock](#) can never be larger than the size of a NAND page.

If [HasHW_ECC](#) is different than 0 than [NumBitsCorrectable](#) represents the maximum number of bit errors the internal HW ECC is able to correct.

6.3.4.16.18 FS_NAND_ECC_RESULT

Description

Information about the ECC number of bits corrected in an ECC block.

Type definition

```
typedef struct {
    U8 CorrectionStatus;
    U8 MaxNumBitsCorrected;
} FS_NAND_ECC_RESULT;
```

Structure members

Member	Description
CorrectionStatus	Indicates if the correction succeeded or failed.
MaxNumBitsCorrected	Maximum number of bit errors detected and corrected in any ECC block of a page.

Additional information

This structure is filled by the `FS_NAND_PHY_TYPE_GET_ECC_RESULT` function of the NAND physical layer to return the result of the bit error correction operation.

Refer to *ECC correction status* on page 581 for a list of permitted values for `CorrectionStatus`.

An ECC block is the number of bytes protected by a single ECC. Typically, the ECC block is 512 bytes large, therefore the number of ECC blocks in a 2 KByte page is 4. Most of the NAND flash devices report the number of bits corrected in each of the ECC blocks. The value stored to `MaxNumBitsCorrected` must be the maximum of these values.

6.3.4.17 Additional physical layer functions

The following functions are optional. They can be called to get information about the NAND flash device and to control additional functionality of physical layers.

Function	Description
FS_NAND_PHY_ReadDeviceId()	Returns the id information stored in a NAND flash device.
FS_NAND_PHY_ReadONFIPara()	Reads the ONFI parameters from a NAND flash.
FS_NAND_PHY_SetHWType()	Configures the hardware access routines for <code>FS_NAND_PHY_ReadDeviceId()</code> and <code>FS_NAND_PHY_ReadONFIPara()</code> .

6.3.4.17.1 FS_NAND_PHY_ReadDeviceId()

Description

Returns the id information stored in a NAND flash device.

Prototype

```
int FS_NAND_PHY_ReadDeviceId(U8    Unit,
                             U8    * pId,
                             U32    NumBytes);
```

Parameters

Parameter	Description
Unit	Index of HW layer connected to NAND flash.
pId	out Identification data read from NAND flash.
NumBytes	Number of bytes to read.

Return value

- = 0 OK, id information read.
- ≠ 0 An error occurred.

Additional information

FS_NAND_PHY_ReadDeviceId() executes the READ ID command to read the id information from the NAND flash device. NumBytes specifies the number of bytes to be read. Refer to the data sheet of the NAND flash device for additional information about the meaning of the data returned by the NAND flash device. Typically, the first byte stores the manufactured id while the second byte provides information about the organization of the NAND flash device.

It is permitted to call FS_NAND_PHY_ReadONFIPara() from FS_X_AddDevices() since it does not require for the file system to be fully initialized and it invokes only functions of the NAND hardware layer. No instance of NAND driver is required to invoke this function.

Typical usage is to determine at runtime the type of NAND driver to be used for the connected NAND flash device.

Example

The following example shows how an application can select at runtime a different NAND drivers based on the type of the used NAND flash.

```
#include "FS.h"

#define ALLOC_SIZE          0x4000    // Memory pool for the file system in bytes

static U32 _aMemBlock[ALLOC_SIZE / 4]; // Memory pool used for semi-dynamic allocation.

/*****
 *
 *     FS_X_AddDevices
 */
void FS_X_AddDevices(void) {
    U8 Id;

    FS_AssignMemory(_aMemBlock, sizeof(_aMemBlock));
    //
    // Read the first byte of the identification array.
    // This byte stores the manufacturer type.
    //
    FS_NAND_PHY_SetHWType(0, &FS_NAND_HW_Default);
    FS_NAND_PHY_ReadDeviceId(0, &Id, sizeof(Id));
    if (Id == 0xEC) {
        //
        // Found a Samsung NAND flash. Use the SLC1 NAND driver.
    }
}
```

```
// ECC is performed by the NAND driver
//
FS_AddDevice(&FS_NAND_Driver);
FS_NAND_SetPhyType(0, &FS_NAND_PHY_2048x8);
FS_NAND_2048x8_SetHWType(0, &FS_NAND_HW_Default);
} else if (Id == 0x2C) {
//
// Found a Micron NAND flash. Use the Universal NAND driver.
// The ECC is performed by the NAND flash.
//
FS_AddDevice(&FS_NAND_UNI_Driver);
FS_NAND_UNI_SetPhyType(0, &FS_NAND_PHY_ONFI);
FS_NAND_UNI_SetECCHook(0, &FS_NAND_ECC_HW_NULL);
FS_NAND_ONFI_SetHWType(0, &FS_NAND_HW_Default);
} else {
//
// NAND flash from another manufacturer, use auto-identification.
//
FS_AddDevice(&FS_NAND_Driver);
FS_NAND_SetPhyType(0, &FS_NAND_PHY_x8);
FS_NAND_x8_SetHWType(0, &FS_NAND_HW_Default);
}
}
```

6.3.4.17.2 FS_NAND_PHY_ReadONFIPara()

Description

Reads the ONFI parameters from a NAND flash.

Prototype

```
int FS_NAND_PHY_ReadONFIPara(U8      Unit,
                             void * pPara);
```

Parameters

Parameter	Description
Unit	Index of HW layer connected to NAND flash.
pPara	out Data of ONFI parameter page read from NAND flash. This parameter can be set to NULL.

Return value

= 0 ONFI parameters read.
 ≠ 0 ONFI is not supported by the NAND flash.

Additional information

Refer to the data sheet of the NAND flash device for a description of the data layout of the returned ONFI parameters.

This function can be used to read the ONFI parameter stored in a NAND flash. It is permitted to call `FS_NAND_PHY_ReadONFIPara()` from `FS_X_AddDevices()` since it does not require for the file system to be fully initialized and it invokes only functions of the NAND hardware layer. No instance of NAND driver is required to invoke this function.

`FS_NAND_PHY_ReadONFIPara()` can also be used to check if the NAND flash device is ONFI compliant by setting `pParam` to NULL.

The size of the buffer passed via `pParam` must be at least 256 bytes large.

Example

This example demonstrates how an application can configure at runtime different NAND driver based on the type of the NAND flash.

```
#include "FS.h"

#define ALLOC_SIZE          0x4000    // Memory pool for the file system in bytes

static U32 _aMemBlock[ALLOC_SIZE / 4]; // Memory pool used for semi-dynamic allocation.

/*****
 *
 *      FS_X_AddDevices
 */
void FS_X_AddDevices(void) {
    int r;

    FS_AssignMemory(_aMemBlock, sizeof(_aMemBlock));
    //
    // Check whether the NAND flash supports ONFI.
    //
    FS_NAND_PHY_SetHWType(0, &FS_NAND_HW_Default);
    r = FS_NAND_PHY_ReadONFIPara(0, NULL);
    if (r != 0) {
        //
        // Found a NAND flash which does not support ONFI.
        //
        FS_AddDevice(&FS_NAND_Driver);
        FS_NAND_SetPhyType(0, &FS_NAND_PHY_2048x8);
    } else {
```

```
//  
// Found a NAND flash which supports ONFI.  
//  
FS_AddDevice(&FS_NAND_UNI_Driver);  
FS_NAND_UNI_SetPhyType(0, &FS_NAND_PHY_ONFI);  
FS_NAND_UNI_SetECCHook(0, &FS_NAND_ECC_HW_NULL);  
}  
}
```

6.3.4.17.3 FS_NAND_PHY_SetHWType()

Description

Configures the hardware access routines for `FS_NAND_PHY_ReadDeviceId()` and `FS_NAND_PHY_ReadONFIPara()`.

Prototype

```
void FS_NAND_PHY_SetHWType(      U8          Unit,
                               const FS_NAND_HW_TYPE * pHWType);
```

Parameters

Parameter	Description
<code>Unit</code>	Index of the physical layer instance (0-based)
<code>pHWType</code>	Type of the hardware layer to use. Cannot be NULL.

Additional information

This function is mandatory if the application calls either `FS_NAND_PHY_ReadDeviceId()` or `FS_NAND_PHY_ReadONFIPara()`. `FS_NAND_PHY_SetHWType()` has to be called once in `FS_X_AddDevices()` for every different `Unit` number passed to `FS_NAND_PHY_ReadDeviceId()` or `FS_NAND_PHY_ReadONFIPara()`.

6.3.4.18 Resource usage

This section describes the ROM and RAM usage of the NAND physical layers.

6.3.4.18.1 ROM usage

The ROM usage depends on the compiler options, the compiler version, and the used CPU. The memory requirements of the NAND physical layers were measured as described in the section *Test procedure* on page 1283.

The following table lists the ROM usage of all the available NOR physical layers.

Name	ROM usage(Kbytes)
512x8	1.3
2048x8	1.6
Two plane 2048x8	1.4
Small 2048x8	1.4
2048x16	1.2
4096x8	1.1
DataFlash	1.7
ONFI	3.8
Read-only ONFI	3.5
Small ONFI	3.6
QSPI	5.2
SPI	5.2
8/16-bit data bus	9.4
8-bit data bus	8.2

6.3.4.18.2 Static RAM usage

Static RAM usage is the amount of RAM required by the driver for static variables inside the driver. The number of bytes can be seen in a compiler list file. The next table lists the static RAM usage of all the available NOR physical layers.

Name	RAM usage(bytes)
512x8	20
2048x8	16
Two plane 2048x8	16
Small 2048x8	16
2048x16	16
4096x8	16
DataFlash	64
ONFI	16
Read-only ONFI	16
Small ONFI	16
QSPI	16
SPI	16
8/16-bit data bus	16
8-bit data bus	16

6.3.4.18.3 Dynamic RAM usage

Dynamic RAM usage is the amount of RAM allocated by the physical layer at runtime. The amount of RAM required depends on the compile time and runtime configuration. The following table lists the the dynamic RAM usage of the available NOR physical layers.

Name	RAM usage(bytes)
512x8	0
2048x8	24
Two plane 2048x8	24
Small 2048x8	24
2048x16	0
4096x8	0
DataFlash	0
ONFI	28
Read-only ONFI	28
Small ONFI	28
QSPI	44
SPI	44
8/16-bit data bus	8
8-bit data bus	8

6.3.5 NAND hardware layer

6.3.5.1 General information

The NAND hardware layer provides functionality for accessing a NAND flash device via the target hardware such as external memory controller, GPIO, SPI, etc. The functions of the NAND hardware layer are called by the NAND physical layer to exchange commands and data with a NAND flash device. Since these functions are hardware dependent, they have to be implemented by the user. emFile comes with template hardware layers and sample implementations for popular evaluation boards that can be used as starting point for implementing new hardware layers. The relevant files are located in the `/Sample/FS/Driver/NAND` folder of the emFile shipment.

6.3.5.2 Hardware layer types

The functions of the NAND hardware layer are organized in a function table implemented a C structure. Different hardware layer types are provided to support different ways of interfacing a NAND flash device. The type of hardware layer an application has to use depends on the type NAND physical layer configured. The following table shows what hardware layer is required by each physical layer.

NAND hardware layer	NAND physical layer
FS_NAND_HW_TYPE	FS_NAND_PHY_512x8 FS_NAND_PHY_2048x8 FS_NAND_PHY_2048x16 FS_NAND_PHY_4096x8 FS_NAND_PHY_x FS_NAND_PHY_x8 FS_NAND_PHY_ONFI
FS_NAND_HW_TYPE_DF	FS_NAND_PHY_DataFlash
FS_NAND_HW_TYPE_QSPI	FS_NAND_PHY_QSPI
FS_NAND_HW_TYPE_SPI	FS_NAND_PHY_SPI

6.3.5.3 Hardware layer API - FS_NAND_HW_TYPE

This NAND hardware layer supports NAND flash devices that can be accessed via an 8- or 16-bit data bus. The functions of this hardware layer are grouped in a structure of type `FS_NAND_HW_TYPE`. The following sections describe these functions in detail.

6.3.5.3.1 FS_NAND_HW_TYPE

Description

NAND hardware layer API for NAND flash devices connected via parallel I/O.

Type definition

```
typedef struct {
    FS_NAND_HW_TYPE_INIT_X8      * pfInit_x8;
    FS_NAND_HW_TYPE_INIT_X16     * pfInit_x16;
    FS_NAND_HW_TYPE_DISABLE_CE   * pfDisableCE;
    FS_NAND_HW_TYPE_ENABLE_CE    * pfEnableCE;
    FS_NAND_HW_TYPE_SET_ADDR_MODE * pfSetAddrMode;
    FS_NAND_HW_TYPE_SET_CMD_MODE * pfSetCmdMode;
    FS_NAND_HW_TYPE_SET_DATA_MODE * pfSetDataMode;
    FS_NAND_HW_TYPE_WAIT_WHILE_BUSY * pfWaitWhileBusy;
    FS_NAND_HW_TYPE_READ_X8      * pfRead_x8;
    FS_NAND_HW_TYPE_WRITE_X8     * pfWrite_x8;
    FS_NAND_HW_TYPE_READ_X16     * pfRead_x16;
    FS_NAND_HW_TYPE_WRITE_X16    * pfWrite_x16;
} FS_NAND_HW_TYPE;
```

Structure members

Member	Description
pfInit_x8	Initializes a NAND flash device with an 8-bit data interface.
pfInit_x16	Initializes a NAND flash device with a 16-bit data interface.
pfDisableCE	Disables the NAND flash device.
pfEnableCE	Enables the NAND flash device.
pfSetAddrMode	Initiates the transfer of an address.
pfSetCmdMode	Initiates the transfer of a command.
pfSetDataMode	Initiates the transfer of data.
pfWaitWhileBusy	Waits for the NAND flash device to become ready.
pfRead_x8	Reads a specified number of bytes from NAND flash device via the 8-bit data interface.
pfWrite_x8	Writes a specified number of bytes to NAND flash device via the 8-bit data interface.
pfRead_x16	Reads a specified number of bytes from NAND flash device via the 16-bit data interface.
pfWrite_x16	Writes a specified number of bytes to NAND flash device via the 16-bit data interface.

6.3.5.3.2 FS_NAND_HW_TYPE_INIT_X8

Description

Initializes the hardware for 8-bit mode access.

Type definition

```
typedef void FS_NAND_HW_TYPE_INIT_X8(U8 Unit);
```

Parameters

Parameter	Description
<code>Unit</code>	Index of the NAND hardware layer instance (0-based)

Additional information

This function is a member of the `FS_NAND_PHY_TYPE` NAND hardware layer API. It has to be implemented by a NAND hardware layer that accesses a NAND flash device via an 8-bit data bus. `FS_NAND_HW_TYPE_INIT_X8` is the first function of the hardware layer API that is called by a NAND physical layer during the mounting of the file system.

This function has to perform any initialization of the MCU hardware required to access the NAND flash device such as clocks, port pins, memory controllers, etc.

6.3.5.3.3 FS_NAND_HW_TYPE_INIT_X16

Description

Initializes the hardware for 16-bit mode access.

Type definition

```
typedef void FS_NAND_HW_TYPE_INIT_X16(U8 Unit);
```

Parameters

Parameter	Description
<code>Unit</code>	Index of the NAND hardware layer instance (0-based)

Additional information

This function is a member of the `FS_NAND_PHY_TYPE` NAND hardware layer API. The implementation of this function is optional for systems that interface to the NAND flash device via an 8-bit data bus. `FS_NAND_HW_TYPE_INIT_X16` must be implemented for systems that have the NAND flash device connected to MCU via an 16-bit data bus.

`FS_NAND_HW_TYPE_INIT_X16` is the first function of the hardware layer API that is called by the NAND physical layer when the NAND flash device is mounted.

6.3.5.3.4 FS_NAND_HW_TYPE_DISABLE_CE

Description

Disables the NAND flash device.

Type definition

```
typedef void FS_NAND_HW_TYPE_DISABLE_CE(U8 Unit);
```

Parameters

Parameter	Description
<code>Unit</code>	Index of the NAND hardware layer instance (0-based)

Additional information

This function is a member of the `FS_NAND_PHY_TYPE` NAND hardware layer API and it is mandatory to be implemented. The implementation of this function can be left empty if the hardware is driving the Chip Enable (CE) signal. Typically, the NAND flash device is disabled by driving the CE signal to a logic low state level.

6.3.5.3.5 FS_NAND_HW_TYPE_ENABLE_CE

Description

Enables the NAND flash device.

Type definition

```
typedef void FS_NAND_HW_TYPE_ENABLE_CE(U8 Unit);
```

Parameters

Parameter	Description
Unit	Index of the NAND hardware layer instance (0-based)

Additional information

This function is a member of the `FS_NAND_PHY_TYPE` NAND hardware layer API. It is mandatory to be implemented by all NAND hardware layers. The implementation of this function can be left empty if the hardware is driving the Chip Enable (CE) signal. Typically, the NAND flash device is enabled by driving the CE signal to a logic-high level.

6.3.5.3.6 FS_NAND_HW_TYPE_SET_ADDR_MODE

Description

Changes the data access to address mode.

Type definition

```
typedef void FS_NAND_HW_TYPE_SET_ADDR_MODE(U8 Unit);
```

Parameters

Parameter	Description
<code>Unit</code>	Index of the NAND hardware layer instance (0-based)

Additional information

This function is a member of the `FS_NAND_PHY_TYPE` NAND hardware layer API. It is mandatory to be implemented by all NAND hardware layers.

After the call to this function the NAND hardware layer has to make sure that any data sent to NAND flash device is interpreted as address information. This can be achieved by setting the Address Latch Enable signal (ALE) signal to logic-high and the Command Latch Enable (CLE) signal to logic low state.

6.3.5.3.7 FS_NAND_HW_TYPE_SET_CMD_MODE

Description

Changes the data access to command mode.

Type definition

```
typedef void FS_NAND_HW_TYPE_SET_CMD_MODE(U8 Unit);
```

Parameters

Parameter	Description
<code>Unit</code>	Index of the NAND hardware layer instance (0-based)

Additional information

This function is a member of the `FS_NAND_PHY_TYPE` NAND hardware layer API. It is mandatory to be implemented by all the NAND hardware layers.

After the call to this function the NAND hardware layer has to make sure that any data sent to NAND flash device is interpreted as command information. This can be achieved by setting the Command Latch Enable (CLE) signal to logic-high and the Address Latch Enable signal (ALE) signal to logic low state.

6.3.5.3.8 FS_NAND_HW_TYPE_SET_DATA_MODE

Description

Changes the data access to data mode.

Type definition

```
typedef void FS_NAND_HW_TYPE_SET_DATA_MODE(U8 Unit);
```

Parameters

Parameter	Description
<code>Unit</code>	Index of the NAND hardware layer instance (0-based)

Additional information

This function is a member of the `FS_NAND_PHY_TYPE` NAND hardware layer API. It is mandatory to be implemented by all the NAND hardware layers.

After the call to this function the NAND hardware layer has to make sure that any data sent to NAND flash device is interpreted as data information. This can be achieved by setting the Command Latch Enable (CLE) and Address Latch Enable signals to logic low state.

6.3.5.3.9 FS_NAND_HW_TYPE_WAIT_WHILE_BUSY

Description

Waits for the NAND flash device to become ready.

Type definition

```
typedef int FS_NAND_HW_TYPE_WAIT_WHILE_BUSY(U8          Unit,
                                             unsigned us);
```

Parameters

Parameter	Description
<code>Unit</code>	Index of the NAND hardware layer instance (0-based)
<code>us</code>	Maximum time to wait in microseconds.

Return value

- = 0 The NAND flash device is ready.
- ≠ 0 The NAND flash device is busy or the operation is not supported.

Additional information

This function is a member of the `FS_NAND_PHY_TYPE` NAND hardware layer API. It is mandatory to be implemented by all the NAND hardware layers.

A NAND hardware layer calls this function every time it checks the status of the NAND flash device. A typical implementation uses the status of the Ready/Busy (R/B) signal that is set to logic low state by the NAND flash device as long as it is busy and it cannot accept and other commands from MCU.

`FS_NAND_HW_TYPE_WAIT_WHILE_BUSY` must return 1 if the status of the NAND flash device cannot be queried via R/B signal. In this case, the NAND hardware layer checks the status via a read status command.

Typically, a NAND flash device does not set R/B signal to logic low state immediately after it accepts a command from MCU but only after a time interval labeled as t_{WB} in the data sheet of the NAND flash device. This means that `FS_NAND_HW_TYPE_WAIT_WHILE_BUSY` has to wait for t_{WB} time interval to elapse before it samples the R/B signal for the first time in order to make sure that it returns correct status information to the NAND physical layer.

6.3.5.3.10 FS_NAND_HW_TYPE_READ_X8

Description

Reads data from NAND flash device via 8-bit data bus.

Type definition

```
typedef void FS_NAND_HW_TYPE_READ_X8(U8      Unit,
                                     void    * pData,
                                     unsigned NumBytes);
```

Parameters

Parameter	Description
<code>Unit</code>	Index of the NAND hardware layer instance (0-based)
<code>pData</code>	out Data read from NAND flash. It cannot be <code>NULL</code> .
<code>NumBytes</code>	Number of bytes to be read. It cannot be 0.

Additional information

This function is a member of the `FS_NAND_PHY_TYPE` NAND hardware layer API. It has to be implemented by a NAND hardware layer that exchanges the data with the NAND flash device via an 8-bit data bus.

`FS_NAND_HW_TYPE_READ_X8` is called by a NAND physical layer in data mode to transfer data from NAND flash device to MCU. It is not called in address and command data access modes.

The transfer of the data is controlled by the MCU using the Read Enable (RE) signal. If the NAND hardware layer exchanges the data via GPIO it has to make sure that the timing of the RE signal meets the specifications of the NAND flash device.

6.3.5.3.11 FS_NAND_HW_TYPE_WRITE_X8

Description

Writes data to NAND flash device via 8-bit data bus.

Type definition

```
typedef void FS_NAND_HW_TYPE_WRITE_X8(
    U8 Unit,
    const void * pData,
    unsigned NumBytes);
```

Parameters

Parameter	Description
<code>Unit</code>	Index of the NAND hardware layer instance (0-based)
<code>pData</code>	in Data to be written to NAND flash. It cannot be <code>NULL</code> .
<code>NumBytes</code>	Number of bytes to be read. It cannot be 0.

Additional information

This function is a member of the `FS_NAND_PHY_TYPE` NAND hardware layer API. It has to be implemented by a NAND hardware layer that exchanges the data with the NAND flash device via an 8-bit data bus.

`FS_NAND_HW_TYPE_WRITE_X8` is called by a NAND physical layer in all data access modes to transfer data from MCU to NAND flash device.

The transfer of the data is controlled by the MCU using the Write Enable (WE) signal. If the NAND hardware layer exchanges the data via GPIO it has to make sure that the timing of the WE signal meets the specifications of the NAND flash device.

6.3.5.3.12 FS_NAND_HW_TYPE_READ_X16

Description

Reads data from NAND flash device via 16-bit data bus.

Type definition

```
typedef void FS_NAND_HW_TYPE_READ_X16(U8      Unit,
                                       void    * pData,
                                       unsigned NumBytes);
```

Parameters

Parameter	Description
<code>Unit</code>	Index of the NAND hardware layer instance (0-based)
<code>pData</code>	out Data read from NAND flash. It cannot be NULL.
<code>NumBytes</code>	Number of bytes to be read. It cannot be 0.

Additional information

This function is a member of the `FS_NAND_PHY_TYPE` NAND hardware layer API. It has to be implemented by a NAND hardware layer that exchanges the data with the NAND flash device via an 16-bit data bus.

`FS_NAND_HW_TYPE_READ_X16` is called by a NAND physical layer in data mode to transfer data from NAND flash device to MCU. It is not called in address and command data access modes.

The transfer of the data is controlled by the MCU using the Read Enable (RE) signal. If the NAND hardware layer exchanges the data via GPIO it has to make sure that the timing of the RE signal meets the specifications of the NAND flash device.

`pData` is aligned to a half-word (2-byte) boundary.

6.3.5.3.13 FS_NAND_HW_TYPE_WRITE_X16

Description

Writes data to NAND flash device via 16-bit data bus.

Type definition

```
typedef void FS_NAND_HW_TYPE_WRITE_X16(
    U8          Unit,
    const void  * pdata,
    unsigned    NumBytes);
```

Parameters

Parameter	Description
<code>Unit</code>	Index of the NAND hardware layer instance (0-based)
<code>pData</code>	in Data to be written to NAND flash. It cannot be NULL.
<code>NumBytes</code>	Number of bytes to be read. It cannot be 0.

Additional information

This function is a member of the `FS_NAND_PHY_TYPE` NAND hardware layer API. It has to be implemented by a NAND hardware layer that exchanges the data with the NAND flash device via an 16-bit data bus.

`FS_NAND_HW_TYPE_WRITE_X16` is called by a NAND physical layer in all data access modes to transfer data from MCU to NAND flash device.

The transfer of the data is controlled by the MCU using the Write Enable (WE) signal. If the NAND hardware layer exchanges the data via GPIO it has to make sure that the timing of the WE signal meets the specifications of the NAND flash device.

`pData` is aligned to a half-word (2-byte) boundary.

6.3.5.3.14 Sample implementation

The following sample implementation uses the GPIO ports of an NXP K66 MCU to interface with a NAND flash device. This NAND hardware layer was tested on the SGGER emPower board (<https://www.segger.com/evaluate-our-software/segger/empower/>)

```

/*****
*                               (c) SEGGER Microcontroller GmbH                               *
*                               The Embedded Experts                                       *
*                               www.segger.com                                             *
*****/

----- END-OF-HEADER -----

File      : FS_NAND_HW_K66_SEGGER_emPower.c
Purpose   : NAND flash hardware layer header file for the SEGGER emPower
            V2 evaluation board.
Literature:
  [1] K66 Sub-Family Reference Manual
  [2] emPower Evaluation and prototyping platform for SEGGER software User Guide & Reference
      Manual
*/

/*****
*
*       #include Section
*
*****/
#include "FS.h"
#include "FS_NAND_HW_K66_SEGGER_emPower.h"
#include "MK66F18.h"

/*****
*
*       Defines, configurable
*
*****/
#ifndef FS_NAND_HW_USE_OS
#define FS_NAND_HW_USE_OS      0           // Enables / disables the
                                         // event-driven operation.
                                         // 0 - OS support disabled.
                                         // 1 - OS support enabled
                                         //      using the OS event of emFile.
                                         // 2 - OS support enabled using
                                         //      OS events of this HW layer.
#endif

/*****
*
*       #include section, conditional
*
*****/
#if FS_NAND_HW_USE_OS
#include "RTOS.h"
#include "FS_OS.h"
#endif // FS_NAND_HW_USE_OS

/*****
*
*       Defines, fixed
*
*****/

/*****
*
*       Port pins
*/
#define NAND_CS_PIN      0
#define NAND_WAIT_PIN   1
#define NAND_ALE_PIN    4
#define NAND_CLE_PIN    5

```

```

#define NAND_nOE_PIN          6
#define NAND_nWE_PIN          7
#define NAND_DATA_MASK        0xff
#define NAND_D0_SHIFT         8
#define NAND_D0_PIN           8
#define NAND_D1_PIN           9
#define NAND_D2_PIN          10
#define NAND_D3_PIN          11
#define NAND_D4_PIN          12
#define NAND_D5_PIN          13
#define NAND_D6_PIN          14
#define NAND_D7_PIN          15

/*****
 *
 *      Macros for pin configuration
 */
#define SET_DATA2INPUT()      GPIOD_PDDR &= ~(NAND_DATA_MASK << NAND_D0_SHIFT)
#define SET_DATA2OUTPUT()    GPIOD_PDDR |= (NAND_DATA_MASK << NAND_D0_SHIFT)

/*****
 *
 *      Macros for pin control
 */
#define NAND_GET_DATA(Data)   Data = *((volatile U8 *)&GPIOD_PDIR + 0x1);
#define NAND_SET_DATA(Data)  *((volatile U8 *)&GPIOD_PDOR + 0x1) = Data;
#define NAND_SET_ALE()       GPIOD_PSOR = (1 << NAND_ALE_PIN);
#define NAND_CLR_ALE()       GPIOD_PCOR = (1 << NAND_ALE_PIN);
#define NAND_SET_CLE()       GPIOD_PSOR = (1 << NAND_CLE_PIN);
#define NAND_CLR_CLE()       GPIOD_PCOR = (1 << NAND_CLE_PIN);
#define NAND_SET_CE()        GPIOD_PSOR = (1 << NAND_CS_PIN);
#define NAND_CLR_CE()        GPIOD_PCOR = (1 << NAND_CS_PIN);
#define NAND_SET_RE()        GPIOD_PSOR = (1 << NAND_nOE_PIN);
#define NAND_CLR_RE()        GPIOD_PCOR = (1 << NAND_nOE_PIN);
#define NAND_SET_WE()        GPIOD_PSOR = (1 << NAND_nWE_PIN);
#define NAND_CLR_WE()        GPIOD_PCOR = (1 << NAND_nWE_PIN);
#define NAND_GET_BUSY()      (GPIOD_PDIR & (1 << NAND_WAIT_PIN))
#define NAND_NOP()           __asm("nop")

/*****
 *
 *      Misc. defines
 */
#define PORTD_IRQ_PRIO        15
#define WAIT_TIMEOUT_MS      1000 // Maximum time to wait for the NAND
                                // flash device to become ready.
#define NUM_LOOPS_TWB        17 // Delay for tWB time.

/*****
 *
 *      Static data
 *
 *****/
/*****/
#if (FS_NAND_HW_USE_OS == 2)
    static U8 _IsEventInitd = 0;
    static OS_EVENT _Event;
#endif // FS_NAND_HW_USE_OS == 2

/*****
 *
 *      Static code
 *
 *****/
/*****/
#if FS_NAND_HW_USE_OS

/*****
 *
 *      _WaitForEvent
 *
 *      Function description
 *      Waits for the interrupt to wake up the task.
 *
 *      Parameters
 *      Timeout      Maximum time to wait for the event in milliseconds.

```

```

*
* Return values
* ==0      OK, event signaled.
* !=0      An error occurred.
*/
static int _WaitForEvent(U32 TimeOut) {
    int r;

    PORTD_PCR1 |= PORT_PCR_IRQC(0xC);           // Generate an interrupt when the
                                                // the busy signal goes HIGH.

#ifdef FS_NAND_HW_USE_OS == 2
    r = OS_EVENT_WaitTimed(&_Event, TimeOut);
#else
    r = FS_OS_Wait(TimeOut);
#endif
    if (r != 0) {
        PORTD_PCR1 &= ~PORT_PCR_IRQC_MASK;     // Disable the interrupt.
        PORTD_PCR1 |= PORT_PCR_ISF_MASK;
    }
    return r;
}

#endif // FS_NAND_HW_USE_OS

/*****
*
*      Static code (public via callback)
*
*****/

/*****
*
*      _HW_EnableCE
*
* Function description
* Enables the NAND flash device.
*
* Parameters
* Unit          Index of the NAND hardware layer instance (0-based)
*/
static void _HW_EnableCE(U8 Unit) {
    FS_USE_PARA(Unit);
    NAND_CLR_CE();
}

/*****
*
*      _HW_DisableCE
*
* Function description
* Disables the NAND flash device.
*
* Parameters
* Unit          Index of the NAND hardware layer instance (0-based)
*/
static void _HW_DisableCE(U8 Unit) {
    FS_USE_PARA(Unit);
    NAND_SET_CE();
}

/*****
*
*      _HW_SetDataMode
*
* Function description
* Changes the data access to data mode.
*
* Parameters
* Unit          Index of the NAND hardware layer instance (0-based)
*/
static void _HW_SetDataMode(U8 Unit) {
    FS_USE_PARA(Unit);
    //
    // nCE low, CLE low, ALE low
    //

```

```

NAND_CLR_CLE();
NAND_CLR_ALE();
}

/*****
*
*   _HW_SetCmdMode
*
*   Function description
*   Changes the data access to command mode.
*
*   Parameters
*   Unit           Index of the NAND hardware layer instance (0-based)
*/
static void _HW_SetCmdMode(U8 Unit) {
    FS_USE_PARA(Unit);
    //
    // nCE low, CLE high, ALE low
    //
    NAND_SET_CLE();
    NAND_CLR_ALE();
}

/*****
*
*   _HW_SetAddr
*
*   Function description
*   Changes the data access to address mode.
*
*   Parameters
*   Unit           Index of the NAND hardware layer instance (0-based)
*/
static void _HW_SetAddrMode(U8 Unit) {
    FS_USE_PARA(Unit);
    //
    // nCE low, CLE low, ALE high
    //
    NAND_CLR_CLE();
    NAND_SET_ALE();
}

/*****
*
*   _HW_Read_x8
*
*   Function description
*   Reads data from NAND flash device via 8-bit data bus.
*
*   Parameters
*   Unit           Index of the NAND hardware layer instance (0-based)
*   pData          [OUT] Data read from NAND flash. It cannot be NULL.
*   NumBytes       Number of bytes to be read. It cannot be 0.
*/
static void _HW_Read_x8(U8 Unit, void * p, unsigned NumBytes) {
    U8 * pData;

    FS_USE_PARA(Unit);
    pData = (U8 *)p;
    SET_DATA2INPUT();
    do {
        NAND_CLR_RE();           // Enable RE (active low)
        //
        // Wait for the data to be available (tREA time).
        // Two NOPs should actually be sufficient but
        // it seems that the MCU requires some time to
        // synchronize the contents of the PDIR register
        // of the GPIO port.
        //
        NAND_NOP();
        NAND_NOP();
        NAND_NOP();
        NAND_NOP();
        NAND_NOP();
        NAND_NOP();
        NAND_NOP();
    } while (1);
}

```

```

    NAND_NOP();
    NAND_GET_DATA(*pData++);
    NAND_SET_RE(); // Disable RE (active low)
} while (--NumBytes);
}

/*****
 *
 *     _HW_Write_x8
 *
 * Function description
 * Writes data to NAND flash device via 8-bit data bus.
 *
 * Parameters
 * Unit          Index of the NAND hardware layer instance (0-based)
 * pData         [IN] Data to be written to NAND flash. It cannot be NULL.
 * NumBytes      Number of bytes to be read. It cannot be 0.
 */
static void _HW_Write_x8(U8 Unit, const void * p, unsigned NumBytes) {
    const U8 * pData;

    FS_USE_PARA(Unit);
    pData = (const U8 *)p;
    SET_DATA2OUTPUT();
    do {
        NAND_SET_DATA(*pData++);
        NAND_CLR_WE(); // Enable WE (active low)
        NAND_NOP();
        NAND_SET_WE(); // Disable WE (active low)
    } while (--NumBytes);
}

/*****
 *
 *     _HW_Init_x8
 *
 * Function description
 * Initializes the hardware for 8-bit mode access.
 *
 * Parameters
 * Unit          Index of the NAND hardware layer instance (0-based)
 */
static void _HW_Init_x8(U8 Unit) {
    FS_USE_PARA(Unit);
#ifdef FS_NAND_HW_USE_OS
    //
    // Disable the interrupt.
    //
    NVIC_DisableIRQ(PORTD_IRQn);
    NVIC_SetPriority(PORTD_IRQn, PORTD_IRQ_Prio);
#endif // FS_NAND_HW_USE_OS
    //
    // Add here the initialization of your NAND hardware
    //
    SIM_SCGC5 |= SIM_SCGC5_PORTD_MASK; // Enable clock for Port D
    PORTD_PCR0 = PORT_PCR_MUX(0x01); // Configure as GPIO
    PORTD_PCR1 = PORT_PCR_MUX(0x01); // Configure as GPIO
    PORTD_PCR1 |= PORT_PCR_PS_MASK // Enable the pull-up.
    PORTD_PCR1 |= PORT_PCR_PE_MASK
    ;
    PORTD_PCR4 = PORT_PCR_MUX(0x01); // Configure as GPIO
    PORTD_PCR5 = PORT_PCR_MUX(0x01); // Configure as GPIO
    PORTD_PCR6 = PORT_PCR_MUX(0x01); // Configure as GPIO
    PORTD_PCR7 = PORT_PCR_MUX(0x01); // Configure as GPIO
    PORTD_PCR8 = PORT_PCR_MUX(0x01); // Configure as GPIO
    PORTD_PCR9 = PORT_PCR_MUX(0x01); // Configure as GPIO
    PORTD_PCR10 = PORT_PCR_MUX(0x01); // Configure as GPIO
    PORTD_PCR11 = PORT_PCR_MUX(0x01); // Configure as GPIO
    PORTD_PCR12 = PORT_PCR_MUX(0x01); // Configure as GPIO
    PORTD_PCR13 = PORT_PCR_MUX(0x01); // Configure as GPIO
    PORTD_PCR14 = PORT_PCR_MUX(0x01); // Configure as GPIO
    PORTD_PCR15 = PORT_PCR_MUX(0x01); // Configure as GPIO
    GPIOD_PDDR |= (1u << NAND_CS_PIN)
    | (1u << NAND_ALE_PIN)
    | (1u << NAND_CLE_PIN)
    | (1u << NAND_nOE_PIN)

```

```

        | (1u << NAND_nWE_PIN)
        ;
    GPIOD_PDDR  &= ~(1 << NAND_WAIT_PIN);
    NAND_SET_RE();           // Disable RE
    NAND_SET_WE();           // Disable WE
    NAND_SET_CLE();          // Disable CLE
    NAND_SET_ALE();          // Disable ALE
    NAND_SET_CE();           // Disable CE
#if FS_NAND_HW_USE_OS
    //
    // Create the OS event and enable the interrupt.
    //
#if (FS_NAND_HW_USE_OS == 2)
    if (_IsEventInitiated == 0) {
        OS_EVENT_Create(&_Event);
        _IsEventInitiated = 1;
    }
#endif // FS_NAND_HW_USE_OS == 2
    NVIC_EnableIRQ(PORTD_IRQn);
#endif
}

/*****
 *
 *      _HW_WaitWhileBusy
 *
 *  Function description
 *  Waits for the NAND flash device to become ready.
 *
 *  Parameters
 *  Unit      Index of the NAND hardware layer instance (0-based)
 *  us        Maximum time to wait in microseconds.
 *
 *  Return value
 *  ==0      The NAND flash device is ready.
 *  !=0      The NAND flash device is busy or the operation is not supported.
 */
static int _HW_WaitWhileBusy(U8 Unit, unsigned us) {
    volatile int NumLoops;

    FS_USE_PARA(Unit);
    FS_USE_PARA(us);
    //
    // Make sure that we do not sample the busy signal too early.
    // In order to do so we have to wait here at least the time
    // specified at tWB in the data sheet of the NAND flash device.
    // Typically this time is about 100 ns. Assuming that the CPU
    // is running at 168 MHz then we have to wait here 100 / 5.9 = 16.9
    // that is about 17 cycles.
    //
    NumLoops = NUM_LOOPS_TWB;
    do {
        NAND_NOP();
    } while (--NumLoops != 0);
    for (;;) {
        if (NAND_GET_BUSY() != 0) {
            break;
        }
    }
#if FS_NAND_HW_USE_OS
    (void)_WaitForEvent(WAIT_TIMEOUT_MS);
#else
    NAND_NOP();
#endif // FS_NAND_HW_USE_OS
    }
    return 0;
}

/*****
 *
 *      Public code
 *
 *****/
}

#if FS_NAND_HW_USE_OS

```

```

/*****
 *
 *      PORTD_IRQHandler
 */
void PORTD_IRQHandler(void);
void PORTD_IRQHandler(void) {
    OS_EnterNestableInterrupt();
    PORTD_PCR1 &= ~PORT_PCR_IRQC_MASK;           // Disable the interrupt.
    PORTD_PCR1 |= PORT_PCR_ISF_MASK;
    #if (FS_NAND_HW_USE_OS == 2)
        OS_EVENT_Set(&_Event);
    #else
        FS_OS_Signal();
    #endif
    OS_LeaveNestableInterrupt();
}

#endif // FS_NAND_HW_USE_OS

/*****
 *
 *      Public data
 */

/*****
 *
 *      FS_NAND_HW_K66_SEGGER_emPower
 */
const FS_NAND_HW_TYPE FS_NAND_HW_K66_SEGGER_emPower = {
    _HW_Init_x8,
    NULL,
    _HW_DisableCE,
    _HW_EnableCE,
    _HW_SetAddrMode,
    _HW_SetCmdMode,
    _HW_SetDataMode,
    _HW_WaitWhileBusy,
    _HW_Read_x8,
    _HW_Write_x8,
    NULL,
    NULL
};

/***** End of file *****/

```

6.3.5.4 Hardware layer API - FS_NAND_HW_TYPE_DF

This hardware layer supports Microchip / Atmel / Adesto DataFlash devices and is used by the `FS_NAND_PHY_DataFlash` physical layer to exchange data with a DataFlash device via a standard SPI interface. The functions of this hardware layer are grouped in the structure of type `FS_NAND_HW_TYPE_DF`. The following sections describe these functions in detail.

6.3.5.4.1 FS_NAND_HW_TYPE_DF

Description

NAND hardware layer API for DataFlash devices.

Type definition

```
typedef struct {
    FS_NAND_HW_TYPE_DF_INIT      * pfInit;
    FS_NAND_HW_TYPE_DF_ENABLE_CS * pfEnableCS;
    FS_NAND_HW_TYPE_DF_DISABLE_CS * pfDisableCS;
    FS_NAND_HW_TYPE_DF_READ      * pfRead;
    FS_NAND_HW_TYPE_DF_WRITE     * pfWrite;
} FS_NAND_HW_TYPE_DF;
```

Structure members

Member	Description
pfInit	Initializes the hardware.
pfEnableCS	Enables the DataFlash device.
pfDisableCS	Disables the DataFlash device.
pfRead	Transfers a specified number of bytes from DataFlash device to MCU.
pfWrite	Transfers a specified number of bytes from MCU to DataFlash device.

6.3.5.4.2 FS_NAND_HW_TYPE_DF_INIT

Description

Initializes the hardware.

Type definition

```
typedef int FS_NAND_HW_TYPE_DF_INIT(U8 Unit);
```

Parameters

Parameter	Description
<code>Unit</code>	Index of the NAND hardware layer instance (0-based)

Return value

= 0 OK, initialization was successful.
 ≠ 0 An error occurred.

Additional information

This function is a member of the `FS_NAND_HW_TYPE_DF` NAND hardware layer API. It is mandatory to be implemented by all the NAND hardware layers of this type. `FS_NAND_HW_TYPE_DF_INIT` is the first function of the hardware layer API that is called by a NAND physical layer during the mounting of the file system.

This function has to perform any initialization of the MCU hardware required to access the DataFlash device such as clocks, port pins, memory controllers, etc.

A DataFlash requires that the SPI communication protocol meets the following requirements:

- 8-bit data length.
- The most significant bit has to be sent out first.
- Chip Select (CS) signal should be initially high to disable the DataFlash device.
- The SPI clock frequency does not have to exceed the maximum clock frequency that is specified by the DataFlash device (Usually: 20MHz).

6.3.5.4.3 FS_NAND_HW_TYPE_DF_ENABLE_CS

Description

Enables the DataFlash device.

Type definition

```
typedef void FS_NAND_HW_TYPE_DF_ENABLE_CS(U8 Unit);
```

Parameters

Parameter	Description
Unit	Index of the NAND hardware layer instance (0-based)

Additional information

This function is a member of the `FS_NAND_HW_TYPE_DF` NAND hardware layer API. It is mandatory to be implemented by all the NAND hardware layers of this type.

The DataFlash device is enabled by driving the Chip Select (CS) signal to logic low state.

6.3.5.4.4 FS_NAND_HW_TYPE_DF_DISABLE_CS

Description

Disables the DataFlash device.

Type definition

```
typedef void FS_NAND_HW_TYPE_DF_DISABLE_CS(U8 Unit);
```

Parameters

Parameter	Description
Unit	Index of the NAND hardware layer instance (0-based)

Additional information

This function is a member of the `FS_NAND_HW_TYPE_DF` NAND hardware layer API. It is mandatory to be implemented by all the NAND hardware layers of this type.

The DataFlash device is disabled by driving the Chip Select (CS) signal to logic-high.

6.3.5.4.5 FS_NAND_HW_TYPE_DF_READ

Description

Transfers a specified number of bytes from DataFlash device to MCU.

Type definition

```
typedef void FS_NAND_HW_TYPE_DF_READ(U8    Unit,  
                                     U8 * pData,  
                                     int   NumBytes);
```

Parameters

Parameter	Description
<code>Unit</code>	Index of the NAND hardware layer instance (0-based)
<code>pData</code>	<code>out</code> Data read from DataFlash device.
<code>NumBytes</code>	Number of bytes to be read.

Additional information

This function is a member of the `FS_NAND_HW_TYPE_DF` NAND hardware layer API. It is mandatory to be implemented by all the NAND hardware layers of this type.

6.3.5.4.6 FS_NAND_HW_TYPE_DF_WRITE

Description

Transfers a specified number of bytes from MCU to DataFlash device.

Type definition

```
typedef void FS_NAND_HW_TYPE_DF_WRITE(
    U8 Unit,
    const U8 * pData,
    int NumBytes);
```

Parameters

Parameter	Description
<code>Unit</code>	Index of the NAND hardware layer instance (0-based)
<code>pData</code>	in Data to be written to DataFlash device.
<code>NumBytes</code>	Number of bytes to be written.

Additional information

This function is a member of the `FS_NAND_HW_TYPE_DF` NAND hardware layer API. It is mandatory to be implemented by all the NAND hardware layers of this type.

6.3.5.4.7 Sample implementation

The following sample implementation uses the SPI controller of a NXP LPC4322 MCU to interface with a DataFlash device. This NAND hardware layer was tested on a SGGGER internal test board.

```

/*****
 *                               (c) SEGGER Microcontroller GmbH                               *
 *                               The Embedded Experts                                       *
 *                               www.segger.com                                           *
 *****/

----- END-OF-HEADER -----

File   : FS_NAND_HW_DF_LPC4322_SEGGER_QSPIFI_Test_Board.c
Purpose : DataFlash hardware layer for NXP LPC4322.
Literature:
 [1] UM10503 LPC43xx ARM Cortex-M4/M0 multi-core microcontroller
*/

/*****
 *
 *   #include section
 *
 *****/
#include "FS.h"

/*****
 *
 *   Defines, configurable
 *
 *****/
#define PER_CLK_HZ          18000000uL
// Frequency of the clock supplied to SPI unit
#ifndef SPI_CLK_HZ
#define SPI_CLK_HZ          25000000uL
// Frequency of the clock supplied to DataFlash device
#endif
#define RESET_DELAY_LOOPS  100000
// Number of software loops to wait for DataFlash to reset

/*****
 *
 *   Defines, non-configurable
 *
 *****/

/*****
 *
 *   SPI unit
 */
#define SPI_BASE_ADDR      0x40100000
#define SPI_CR              (*(volatile U32*)(SPI_BASE_ADDR + 0x00))
// SPI Control Register
#define SPI_SR              (*(volatile U32*)(SPI_BASE_ADDR + 0x04))
// SPI Status Register
#define SPI_DR              (*(volatile U32*)(SPI_BASE_ADDR + 0x08))
// SPI Data Register
#define SPI_CCR             (*(volatile U32*)(SPI_BASE_ADDR + 0x0C))
// SPI Clock Counter Register
#define SPI_TCR             (*(volatile U32*)(SPI_BASE_ADDR + 0x10))
// SPI Test Control register
#define SPI_TSR             (*(volatile U32*)(SPI_BASE_ADDR + 0x14))
// SPI Test Status register
#define SPI_INT             (*(volatile U32*)(SPI_BASE_ADDR + 0x1C))
// SPI Interrupt Flag

/*****
 *
 *   Clock generation unit
 */
#define CGU_BASE_ADDR      0x40050000

```

```

#define BASE_SPI_CLK          (*(volatile U32*)(CGU_BASE_ADDR + 0x0074))

/*****
 *
 *      Clock control unit 1
 */
#define CCU1_BASE_ADDR        0x40051000
#define CLK_SPI_CFG           (*(volatile U32*)(CCU1_BASE_ADDR + 0x0A00))
#define CLK_SPI_STAT          (*(volatile U32*)(CCU1_BASE_ADDR + 0x0A04))

/*****
 *
 *      System control unit
 */
#define SCU_BASE_ADDR         0x40086000
#define SFSP3_2               (*(volatile U32*)(SCU_BASE_ADDR + 0x188))
    // Pin configuration register for pin P3_2
#define SFSP3_3               (*(volatile U32*)(SCU_BASE_ADDR + 0x18C))
    // Pin configuration register for pin P3_3
#define SFSP3_6               (*(volatile U32*)(SCU_BASE_ADDR + 0x198))
    // Pin configuration register for pin P3_6
#define SFSP3_7               (*(volatile U32*)(SCU_BASE_ADDR + 0x19C))
    // Pin configuration register for pin P3_7
#define SFSP3_8               (*(volatile U32*)(SCU_BASE_ADDR + 0x1A0))
    // Pin configuration register for pin P3_8

/*****
 *
 *      GPIO unit
 */
#define GPIO_BASE_ADDR        0x400F4000
#define GPIO_DIR5             (*(volatile U32*)(GPIO_BASE_ADDR + 0x2014))
    // Direction registers port 5
#define GPIO_SET5             (*(volatile U32*)(GPIO_BASE_ADDR + 0x2214))
    // Set register for port 5
#define GPIO_CLR5             (*(volatile U32*)(GPIO_BASE_ADDR + 0x2294))
    // Clear register for port 5

/*****
 *
 *      Misc. defines
 */
#define CGU_IDIV_BIT          2
#define CGU_AUTOBLOCK_BIT    11
#define CGU_CLK_SEL_BIT      24
#define SFS_MODE_BIT         0
#define SFS_EPUN_BIT         4
#define SFS_EHS_BIT          5
#define SFS_EZI_BIT          6
#define SFS_ZIF_BIT          7
#define CLK_STAT_RUN_BIT     0
#define CLK_CFG_RUN_BIT     0
#define NOR_CS_BIT           11
#define CR_MSTR_BIT          5
#define SR_SPIF              7
#define CCR_COUNTER_MAX      0xFE // The actual maximum value is
    // 0xFF but it has to be a multiple of 2
#define NOR_RESET_BIT        9

/*****
 *
 *      Static code
 *
 *****/

/*****
 *
 *      _SetSpeed
 *
 *      Function description
 *      Configures the speed of the clock supplied NOR flash device.
 *
 *      Return value
 *      Frequency of the SPI clock in Hz.
 */

```



```

static U32 _SetSpeed(unsigned MaxFreq_Hz) {
    U32 Div;
    U32 Freq_Hz;

    //
    // According to [1] the clock divisor has to be >= 8 and a multiple of 2.
    //
    Div = 8;
    while (1) {
        Freq_Hz = PER_CLK_HZ / Div;
        if (Freq_Hz <= MaxFreq_Hz) {
            break;
        }
        Div += 2;
        if (Div >= CCR_COUNTER_MAX) {
            Div = CCR_COUNTER_MAX;
            Freq_Hz = PER_CLK_HZ / Div;
            break;
        }
    }
    SPI_CCR = Div;
    return Freq_Hz;
}

/*****
 *
 *      _TransferByte
 *
 * Function description
 * Exchanges 8 bits of data with the NOR flash.
 *
 * Parameters
 * Data      Data to be sent to NOR flash.
 *
 * Return value
 * The data received from NOR flash
 */
static U8 _Transfer8Bits(U8 Data) {
    SPI_DR = Data;
    while (1) {
        if (SPI_SR & (1uL << SR_SPIF)) {
            break;
        }
    }
    Data = SPI_DR;
    return Data;
}

/*****
 *
 *      Public code (via callback)
 *
 *****/

/*****
 *
 *      _HW_Init
 *
 * Function description
 * Initialize the hardware before accessing the device.
 *
 * Parameters
 * Unit      Device index
 *
 * Return Value
 * ==0      Hardware successfully initialized
 * !=0      An error occurred
 */
static int _HW_Init(U8 Unit) {
    unsigned NumLoops;

    FS_USE_PARA(Unit);    // This device has only one HW unit.
    BASE_SPI_CLK = 0
        | 9uL << CGU_CLK_SEL_BIT    // Use PLL1 as clock generator
        | 1uL << CGU_AUTOBLOCK_BIT

```

```

;
//
// Enable the SPI clock if required.
//
if ((CLK_SPI_STAT & (1uL << CLK_STAT_RUN_BIT)) == 0) {
    CLK_SPI_CFG |= (1uL << CLK_CFG_RUN_BIT);
    while (1) {
        if (CLK_SPI_STAT & (1uL << CLK_CFG_RUN_BIT)) {
            ;
        }
    }
}
//
// Clock pin (SPI_CLK).
//
SFSP3_3 = 0
    | (1uL << SFS_MODE_BIT)           // Controlled by SPI unit.
    | (1uL << SFS_EPUN_BIT)
    | (1uL << SFS_EHS_BIT)
    | (1uL << SFS_EZI_BIT)
;

//
// Master In Slave Out (SPI_MISO).
//
SFSP3_6 = 0
    | (1uL << SFS_MODE_BIT)           // Controlled by SPI unit.
    | (1uL << SFS_EPUN_BIT)
    | (1uL << SFS_EZI_BIT)
;

//
// Master Out Slave In (SPI_MOSI).
//
SFSP3_7 = 0
    | (1uL << SFS_MODE_BIT)           // Controlled by SPI unit.
    | (1uL << SFS_EPUN_BIT)
    | (1uL << SFS_EZI_BIT)
;

//
// Chip select pin (SPI_CS).
//
SFSP3_8 = 0
    | (4uL << SFS_MODE_BIT)           // GPIO controlled by the this hardware layer.
    | (1uL << SFS_EPUN_BIT)
;

GPIO_DIR5 |= 1uL << NOR_CS_BIT;
GPIO_SET5 = 1uL << NOR_CS_BIT;       // Set to idle state.
//
// Reset pin. Present only on 16-pin devices.
//
SFSP3_2 = 0
    | (4uL << SFS_MODE_BIT)           // Controlled by this HW layer.
    | (1uL << SFS_EPUN_BIT)
;

GPIO_DIR5 |= 1uL << NOR_RESET_BIT;
//
// Reset the NOR device.
//
GPIO_CLR5 = 1uL << NOR_RESET_BIT;     // Assert reset signal (active low).
NumLoops = RESET_DELAY_LOOPS;
do {
    ;
} while (--NumLoops);
GPIO_SET5 = 1uL << NOR_RESET_BIT;     // De-assert reset signal (active low).
//
// Configure the SPI unit.
//
SPI_CR = 0
    | (1uL << CR_MSTR_BIT)
;
(void)_SetSpeed(SPI_CLK_HZ);
return 0;
}

/*****
*
*      _HW_EnableCS
*****/

```

```

*
* Function description
*   Sets the device active using the chip select (CS) line.
*
* Parameters
*   Unit      Device index
*/
static void _HW_EnableCS(U8 Unit) {
    FS_USE_PARA(Unit);
    GPIO_CLR5 = 1uL << NOR_CS_BIT;    // The CS signal is active low.
}

/*****
*
*   _HW_DisableCS
*
* Function description
*   Sets the device inactive using the chip select (CS) line.
*
* Parameters
*   Unit      Device index
*/
static void _HW_DisableCS(U8 Unit) {
    FS_USE_PARA(Unit);
    GPIO_SET5 = 1uL << NOR_CS_BIT;    // The CS signal is active low.
}

/*****
*
*   _HW_Read
*
* Function description
*   Reads a specified number of bytes from device.
*
* Parameters
*   Unit      Device index
*   pData     Pointer to a data buffer
*   NumBytes  Number of bytes
*/
static void _HW_Read(U8 Unit, U8 * pData, int NumBytes) {
    FS_USE_PARA(Unit);
    do {
        *pData++ = _Transfer8Bits(0xFF);
    } while (--NumBytes);
}

/*****
*
*   _HW_Write
*
* Function description
*   Writes a specified number of bytes from data buffer to device.
*
* Parameters
*   Unit      Device index
*   pData     Pointer to a data buffer
*   NumBytes  Number of bytes
*/
static void _HW_Write(U8 Unit, const U8 * pData, int NumBytes) {
    FS_USE_PARA(Unit);
    do {
        (void)_Transfer8Bits(*pData++);
    } while (--NumBytes);
}

/*****
*
*   Public data
*
*****/
const FS_NAND_HW_TYPE_DF FS_NAND_HW_DF_LPC4322_SEGGER_QSPIFI_Test_Board = {
    _HW_Init,
    _HW_EnableCS,
    _HW_DisableCS,
    _HW_Read,

```

```
_HW_Write  
};  
  
/***** End of file *****/
```

6.3.5.5 Hardware layer API - FS_NAND_HW_TYPE_QSPI

This hardware layer supports any serial NAND flash device with a standard, dual or quad SPI interface. It is used by the `FS_NAND_PHY_QSPI` physical layer to exchange data with a NAND flash device that supports such an interface. Typically, the implementation of `FS_NAND_HW_TYPE_QSPI` hardware layer makes use of a SPI controller that is able to exchange the data via two or four data lines. This kind of SPI controllers are found on most of the popular MCUs and they are typically used to execute code in-place from an external NOR flash device but they can be equally well used to exchange data with a serial NAND flash device.

The functions of this hardware layer are grouped in the structure of type `FS_NAND_HW_TYPE_QSPI`. The following sections describe these functions in detail.

6.3.5.5.1 FS_NAND_HW_TYPE_QSPI

Description

NAND hardware layer API for NAND flash devices connected via quad and dual SPI.

Type definition

```
typedef struct {
    FS_NAND_HW_TYPE_QSPI_INIT      * pFInit;
    FS_NAND_HW_TYPE_QSPI_EXEC_CMD * pFExecCmd;
    FS_NAND_HW_TYPE_QSPI_READ_DATA * pFReadData;
    FS_NAND_HW_TYPE_QSPI_WRITE_DATA * pFWriteData;
    FS_NAND_HW_TYPE_QSPI_POLL      * pFPoll;
    FS_NAND_HW_TYPE_QSPI_DELAY     * pFDelay;
    FS_NAND_HW_TYPE_QSPI_LOCK      * pFLock;
    FS_NAND_HW_TYPE_QSPI_UNLOCK    * pFUnlock;
} FS_NAND_HW_TYPE_QSPI;
```

Structure members

Member	Description
pFInit	Initializes the hardware.
pFExecCmd	Executes a command without data transfer.
pFReadData	Transfers data from NAND flash device to MCU.
pFWriteData	Transfers data from MCU to NAND flash device.
pFPoll	Sends a command repeatedly and checks the response data for a specified condition.
pFDelay	Blocks the execution for the specified number of milliseconds.
pFLock	Requests exclusive access to SPI bus.
pFUnlock	Releases the exclusive access of SPI bus.

6.3.5.5.2 FS_NAND_HW_TYPE_QSPI_INIT

Description

Initializes the hardware.

Type definition

```
typedef int FS_NAND_HW_TYPE_QSPI_INIT(U8 Unit);
```

Parameters

Parameter	Description
<code>Unit</code>	Index of the NAND hardware layer instance (0-based)

Return value

Frequency of the QSPI clock in kHz.

Additional information

This function is a member of the `FS_NAND_HW_TYPE_QSPI` NAND hardware layer API. It is mandatory to be implemented by all the NAND hardware layers of this type.

This function has to configure anything necessary for the data transfer via QSPI such as clocks, port pins, QSPI peripheral, DMA, etc.

The frequency value returned by the function has to be greater than or equal to the actual clock frequency used to transfer the data via QSPI. The `FS_NAND_PHY_QSPI` physical layer uses this value to calculate the number of software cycles it has to wait for NAND flash device to finish an operation before a timeout error is reported. `FS_NAND_HW_TYPE_QSPI_INIT` must return 0 if the clock frequency is unknown. In this case, the `FS_NAND_PHY_QSPI` physical layer waits indefinitely for the end of a NAND flash operation and it never reports a timeout error.

6.3.5.5.3 FS_NAND_HW_TYPE_QSPI_EXEC_CMD

Description

Executes a command without data transfer.

Type definition

```
typedef int FS_NAND_HW_TYPE_QSPI_EXEC_CMD(U8 Unit,
                                           U8 Cmd,
                                           U8 BusWidth);
```

Parameters

Parameter	Description
<code>Unit</code>	Index of the NAND hardware layer instance (0-based)
<code>Cmd</code>	Code of the command to be sent.
<code>BusWidth</code>	Number of data lines to be used for sending the command code.

Return value

= 0 OK, command sent.
 ≠ 0 An error occurred.

Additional information

This function is a member of the `FS_NAND_HW_TYPE_QSPI` NAND hardware layer API. It is mandatory to be implemented by all the NAND hardware layers of this type.

`FS_NAND_HW_TYPE_QSPI_EXEC_CMD` must to send a 8 bits to NAND flash device containing the value specified via `Cmd`.

`BusWidth` specifies the number of data lines to be used when sending the command code. Permitted values are:

- 1 for standard SPI
- 2 for quad SPI (2 data lines)
- 4 for quad SPI (4 data lines)

Please note that this is not an encoded value such as the value passed via `BusWidth` in a call to `FS_NAND_HW_TYPE_QSPI_READ_DATA`, `FS_NAND_HW_TYPE_QSPI_WRITE_DATA` or `FS_NAND_HW_TYPE_QSPI_POLL`.

6.3.5.5.4 FS_NAND_HW_TYPE_QSPI_READ_DATA

Description

Transfers data from NAND flash device to MCU.

Type definition

```
typedef int FS_NAND_HW_TYPE_QSPI_READ_DATA(
    U8      Unit,
    U8      Cmd,
    const U8 * pPara,
    unsigned NumBytesPara,
    unsigned NumBytesAddr,
    U8      * pData,
    unsigned NumBytesData,
    U16     BusWidth);
```

Parameters

Parameter	Description
<code>Unit</code>	Index of the NAND hardware layer instance (0-based)
<code>Cmd</code>	Code of the command to be sent.
<code>pPara</code>	Additional command parameters (can be NULL).
<code>NumBytesPara</code>	Number of additional bytes to be sent after command. Can be 0 if <code>pPara</code> is NULL.
<code>NumBytesAddr</code>	Number of address bytes to be sent. Can be 0 if <code>pPara</code> is NULL.
<code>pData</code>	Data received from the NAND flash device.
<code>NumBytesData</code>	Number of bytes to be received from the NAND flash device.
<code>BusWidth</code>	Specifies the number of data lines to be used during the data transfer.

Return value

= 0 OK, data transferred.
 ≠ 0 An error occurred.

Additional information

This function is a member of the `FS_NAND_HW_TYPE_QSPI` NAND hardware layer API. It is mandatory to be implemented by all the NAND hardware layers of this type.

The data has to be sent in this order: `Cmd` (1 byte) and `pPara` (`NumBytesPara` bytes). The first `NumBytesAddr` bytes in `pPara` represent the address bytes while the rest until `NumBytesPara` bytes are dummy bytes. These values are useful for QSPI hardware that can differentiate between address and dummy bytes. If `NumBytesPara` and `NumBytesAddr` are equal, no dummy bytes have to be sent. `NumBytesPara` is never be smaller than `NumBytesAddr`. The data received from NAND flash has to be stored to `pData` (`NumBytesData` bytes).

The number of data lines to be used during the data transfer is specified via `BusWidth`. The value is encoded with each nibble (4 bits) specifying the number of data lines for one part of the data transfer. The macros *SPI bus width decoding* on page 704 can be used to decode the number of data lines of each part of the request (command and address) and of the response (data). The dummy bytes have to be sent using the number of data lines returned by `FS_BUSWIDTH_GET_ADDR()`.

6.3.5.5.5 FS_NAND_HW_TYPE_QSPI_WRITE_DATA

Description

Transfers data from MCU to NAND flash device.

Type definition

```
typedef int FS_NAND_HW_TYPE_QSPI_WRITE_DATA(
    U8      Unit,
    U8      Cmd,
    const U8 * pPara,
    unsigned NumBytesPara,
    unsigned NumBytesAddr,
    const U8 * pData,
    unsigned NumBytesData,
    U16     BusWidth);
```

Parameters

Parameter	Description
<code>Unit</code>	Index of the NAND hardware layer instance (0-based)
<code>Cmd</code>	Code of the command to be sent.
<code>pPara</code>	Additional command parameters (can be NULL).
<code>NumBytesPara</code>	Number of additional bytes to be sent after command. Can be 0 if <code>pPara</code> is NULL.
<code>NumBytesAddr</code>	Number of address bytes to be sent. Can be 0 if <code>pPara</code> is NULL.
<code>pData</code>	Data to be sent to NAND flash device.
<code>NumBytesData</code>	Number of data bytes to be sent to NAND flash device.
<code>BusWidth</code>	Specifies the number of data lines to be used during the data transfer.

Additional information

This function is a member of the `FS_NAND_HW_TYPE_QSPI` NAND hardware layer API. It is mandatory to be implemented by all the NAND hardware layers of this type.

The data has to be sent in this order: `Cmd` (1 byte), `pPara` (`NumBytesPara` bytes), `pData` (`NumBytesData` bytes). The first `NumBytesAddr` bytes in `pPara` represent the address bytes while the rest until `NumBytesPara` bytes are dummy bytes. These values are useful for QSPI hardware that can differentiate between address and dummy bytes. If `NumBytesPara` and `NumBytesAddr` are equal, no dummy bytes have to be sent. `NumBytesPara` will never be smaller than `NumBytesAddr`.

The number of data lines to be used during the data transfer is specified via `BusWidth`. The value is encoded with each nibble specifying the number of data lines for one part of the data transfer. The macros *SPI bus width decoding* on page 704 can be used to decode the number of data lines of each part of the request (command, address and data). The dummy bytes have to be sent using the number of data lines returned by `FS_BUSWIDTH_GET_ADDR()`.

6.3.5.5.6 FS_NAND_HW_TYPE_QSPI_POLL

Description

Sends a command repeatedly and checks the response data for a specified condition.

Type definition

```
typedef int FS_NAND_HW_TYPE_QSPI_POLL(
    U8      Unit,
    U8      Cmd,
    const U8 * pPara,
    unsigned NumBytesPara,
    U8      BitPos,
    U8      BitValue,
    U32     Delay,
    U32     TimeOut_ms,
    U16     BusWidth);
```

Parameters

Parameter	Description
<code>Unit</code>	Index of the NAND hardware layer instance (0-based)
<code>Cmd</code>	Code of the command to be sent.
<code>pPara</code>	Additional command parameters (can be NULL).
<code>NumBytesPara</code>	Number of additional bytes to be sent after command. Can be 0 if <code>pPara</code> is NULL.
<code>BitPos</code>	Position of the bit inside response data that has to be checked (0-based, with 0 being LSB)
<code>BitValue</code>	Bit value to wait for.
<code>Delay_ms</code>	Time between two command executions.
<code>TimeOut_ms</code>	Maximum time to wait for the bit at <code>BitPos</code> to be set to <code>BitValue</code> .
<code>BusWidth</code>	Specifies how many data lines have to be used for sending the command and parameters and for reading the data.

Return value

> 0 Error, timeout occurred.
 = 0 OK, bit set to specified value.
 < 0 Error, feature not supported.

Additional information

This function is a member of the `FS_NAND_HW_TYPE_QSPI` NAND hardware layer API. The implementation of this function is optional. `FS_NAND_HW_TYPE_QSPI_POLL` is called by the QSPI NAND physical layer when it has to wait for the NAND flash device to reach a certain status.

`FS_NAND_HW_TYPE_QSPI_POLL` has to read periodically a byte of data from the NAND flash device until the value of the bit at `BitPos` in the returned data byte is set to a value specified by `BitValue`. The data is read by sending a command with a code specified by `Cmd` followed by an optional number of additional bytes specified by `pPara` and `NumBytesPara`. Then 8 bits of data are transferred from NAND flash device to MCU and this the value stores the bit to be checked.

The number of data lines to be used during the data transfer is specified via `BusWidth`. The value is encoded with each nibble specifying the number of data lines for one part of the data transfer. The macros *SPI bus width decoding* on page 704 can be used to decode the number of data lines of each part of the request (command, parameters and data). The `pPara` data has to be sent using the number of data lines returned by `FS_BUSWIDTH_GET_ADDR()`.

The time `FS_NAND_HW_TYPE_QSPI_POLL` waits for the condition to be true shall not exceed the number of milliseconds specified by `TimeOut_ms`. `Delay_ms` specifies the number of milliseconds that can elapse between the execution of two consecutive commands.

6.3.5.5.7 FS_NAND_HW_TYPE_QSPI_DELAY

Description

Blocks the execution for the specified number of milliseconds.

Type definition

```
typedef void FS_NAND_HW_TYPE_QSPI_DELAY(U8 Unit,  
                                         int ms);
```

Parameters

Parameter	Description
<code>Unit</code>	Index of the NAND hardware layer instance (0-based)
<code>ms</code>	Number of milliseconds to wait.

Additional information

This function is a member of the `FS_NAND_HW_TYPE_QSPI` NAND hardware layer API. It is mandatory to be implemented by all the NAND hardware layers of this type.

The time `FS_NAND_HW_TYPE_QSPI_DELAY` blocks does not have to be accurate. That is the function can block the execution longer than the number of specified milliseconds but no less than that.

6.3.5.5.8 FS_NAND_HW_TYPE_QSPI_LOCK

Description

Requests exclusive access to SPI bus.

Type definition

```
typedef void FS_NAND_HW_TYPE_QSPI_LOCK(U8 Unit);
```

Parameters

Parameter	Description
<code>Unit</code>	Index of the NAND hardware layer instance (0-based)

Additional information

This function is a member of the `FS_NAND_HW_TYPE_QSPI` NAND hardware layer API. The implementation of this function is optional.

The `FS_NAND_PHY_QSPI` physical layer calls this function to indicate that it needs exclusive to access the NAND flash device via the SPI bus. It is guaranteed that the `FS_NAND_PHY_QSPI` physical layer does not attempt to communicate via the SPI bus before calling this function first. It is also guaranteed that `FS_NAND_HW_TYPE_QSPI_LOCK` and `FS_NAND_HW_TYPE_QSPI_UNLOCK` are called in pairs.

`FS_NAND_HW_TYPE_QSPI_UNLOCK` and `FS_NAND_HW_TYPE_QSPI_LOCK` can be used to synchronize the access to the SPI bus when other devices than the NAND flash are connected to it. A possible implementation would make use of an OS semaphore that is acquired in this function and released in `FS_NAND_HW_TYPE_QSPI_UNLOCK`.

6.3.5.5.9 FS_NAND_HW_TYPE_QSPI_UNLOCK

Description

Releases the exclusive access of SPI bus.

Type definition

```
typedef void FS_NAND_HW_TYPE_QSPI_UNLOCK(U8 Unit);
```

Parameters

Parameter	Description
<code>Unit</code>	Index of the NAND hardware layer instance (0-based)

Additional information

This function is a member of the `FS_NAND_HW_TYPE_QSPI` NAND hardware layer API. The implementation of this function is optional.

The `FS_NAND_PHY_QSPI` physical layer calls this function when it no longer needs to access the NAND flash device via the SPI bus. It is guaranteed that the `FS_NAND_PHY_QSPI` physical layer does not attempt to communicate via the SPI bus before calling `FS_NAND_HW_TYPE_QSPI_LOCK`. It is also guaranteed that `FS_NAND_HW_TYPE_QSPI_UNLOCK` and `FS_NAND_HW_TYPE_QSPI_LOCK` are called in pairs.

`FS_NAND_HW_TYPE_QSPI_UNLOCK` and `FS_NAND_HW_TYPE_QSPI_LOCK` can be used to synchronize the access to the SPI bus when other devices than the NAND flash are connected to it. A possible implementation would make use of an OS semaphore that is acquired in this function and released in `FS_NAND_HW_TYPE_QSPI_UNLOCK`.

6.3.5.5.10 SPI bus width decoding

Description

Macros for the handling of SPI bus width.

Definition

```
#define FS_BUSWIDTH_GET_CMD(BusWidth)      (((BusWidth) >> FS_BUSWIDTH_CMD_SHIFT)
& FS_BUSWIDTH_MASK)
#define FS_BUSWIDTH_GET_ADDR(BusWidth)
(((BusWidth) >> FS_BUSWIDTH_ADDR_SHIFT) & FS_BUSWIDTH_MASK)
#define FS_BUSWIDTH_GET_DATA(BusWidth)
(((BusWidth) >> FS_BUSWIDTH_DATA_SHIFT) & FS_BUSWIDTH_MASK)
```

Symbols

Definition	Description
FS_BUSWIDTH_GET_CMD(BusWidth)	Returns the number of data lines to be used for sending the command code.
FS_BUSWIDTH_GET_ADDR(BusWidth)	Returns the number of data lines to be used for sending the data address.
FS_BUSWIDTH_GET_DATA(BusWidth)	Returns the number of data lines to be used for sending and receiving of the user data.

Additional information

The functions of the FS_NOR_HW_TYPE_SPIFI NOR hardware layer and of the FS_NAND_HW_TYPE_QSPI NAND hardware layer that exchange data with the storage device take a parameter that specifies how many data lines have to be used to send different parts of a request and to receive the answer. The value of this parameter is encoded as a 16-bit value and the macros in this section can help extract the bus width value for a specific part of the request and response.

The value is encoded as follows:

Bit range	Description
0-3	Number of data lines to be used to transfer the data.
4-7	Number of data lines to be used to transfer the address.
8-11	Number of data lines to be used to transfer the command.

6.3.5.5.11 Sample implementation

The sample implementation listed below uses the QUADSPI controller of an ST STM32H743 MCU to interface with a serial NAND flash device. This NAND hardware layer was tested on a SGGGER internal test board.

```

/*****
*                               (c) SEGGER Microcontroller GmbH                               *
*                               The Embedded Experts                                       *
*                               www.segger.com                                           *
*****

----- END-OF-HEADER -----

File   : FS_NAND_HW_QSPI_STM32H743_SEGGER_QSPI_Flash_Evaluator.c
Purpose: HW layer for quad and dual serial NAND flash for ST STM32H743.
Literature:
[1] RM0433 Reference manual STM32H7x3 advanced ARM-based 32-bit MCUs
[2] STM32H753xI Errata sheet STM32H753xI rev Y device limitations
*/

/*****
*
*   #include section
*
*****
*/
#include "FS.h"

/*****
*
*   Defines, configurable
*
*****
*/
#ifndef FS_NAND_HW_PER_CLK_HZ
#define FS_NAND_HW_PER_CLK_HZ      24000000    // Clock of Quad-SPI unit
#endif

#ifndef FS_NAND_HW_NAND_CLK_HZ
#define FS_NAND_HW_NAND_CLK_HZ    48000000    // Frequency of the clock
// supplied to NAND flash device
#endif

#ifndef FS_NAND_HW_CYCLES_PER_MS
#define FS_NAND_HW_CYCLES_PER_MS  10000      // Number of software loops
// create a lms delay
#endif

/*****
*
*   Defines, fixed
*
*****
*/

/*****
*
*   QSPI registers
*
*/
#define QUADSPI_BASE_ADDR          0x52005000uL
#define QUADSPI_CR                  (*(volatile U32 *) (QUADSPI_BASE_ADDR + 0x00))
#define QUADSPI_DCR                  (*(volatile U32 *) (QUADSPI_BASE_ADDR + 0x04))
#define QUADSPI_SR                    (*(volatile U32 *) (QUADSPI_BASE_ADDR + 0x08))
#define QUADSPI_FCR                    (*(volatile U32 *) (QUADSPI_BASE_ADDR + 0x0C))
#define QUADSPI_DLR                    (*(volatile U32 *) (QUADSPI_BASE_ADDR + 0x10))
#define QUADSPI_CCR                    (*(volatile U32 *) (QUADSPI_BASE_ADDR + 0x14))
#define QUADSPI_AR                      (*(volatile U32 *) (QUADSPI_BASE_ADDR + 0x18))
#define QUADSPI_ABR                    (*(volatile U32 *) (QUADSPI_BASE_ADDR + 0x1C))
#define QUADSPI_DR                      (*(volatile U32 *) (QUADSPI_BASE_ADDR + 0x20))
#define QUADSPI_DR_BYTE                  (*(volatile U8 *) (QUADSPI_BASE_ADDR + 0x20))
#define QUADSPI_PSMKR                  (*(volatile U32 *) (QUADSPI_BASE_ADDR + 0x24))
#define QUADSPI_PSMAR                  (*(volatile U32 *) (QUADSPI_BASE_ADDR + 0x28))
#define QUADSPI_PIR                    (*(volatile U32 *) (QUADSPI_BASE_ADDR + 0x2C))
#define QUADSPI_LPTR                    (*(volatile U32 *) (QUADSPI_BASE_ADDR + 0x30))

```

```

/*****
 *
 *      Port B registers
 */
#define GPIOB_BASE_ADDR      0x58020400uL
#define GPIOB_MODER          (*(volatile U32 *) (GPIOB_BASE_ADDR + 0x00))
#define GPIOB_OSPEEDR        (*(volatile U32 *) (GPIOB_BASE_ADDR + 0x08))
#define GPIOB_PUPDR          (*(volatile U32 *) (GPIOB_BASE_ADDR + 0x0C))
#define GPIOB_ODR             (*(volatile U32 *) (GPIOB_BASE_ADDR + 0x14))
#define GPIOB_AFRL           (*(volatile U32 *) (GPIOB_BASE_ADDR + 0x20))

/*****
 *
 *      Port F registers
 */
#define GPIOF_BASE_ADDR      0x58021400uL
#define GPIOF_MODER          (*(volatile U32 *) (GPIOF_BASE_ADDR + 0x00))
#define GPIOF_OSPEEDR        (*(volatile U32 *) (GPIOF_BASE_ADDR + 0x08))
#define GPIOF_PUPDR          (*(volatile U32 *) (GPIOF_BASE_ADDR + 0x0C))
#define GPIOF_ODR             (*(volatile U32 *) (GPIOF_BASE_ADDR + 0x14))
#define GPIOF_AFRH           (*(volatile U32 *) (GPIOF_BASE_ADDR + 0x20))
#define GPIOF_AFRH           (*(volatile U32 *) (GPIOF_BASE_ADDR + 0x24))

/*****
 *
 *      Reset and clock control
 */
#define RCC_BASE_ADDR        0x58024400uL
#define RCC_AHB3STR          (*(volatile U32*) (RCC_BASE_ADDR + 0x7C))
#define RCC_AHB3ENR          (*(volatile U32*) (RCC_BASE_ADDR + 0xD4))
#define RCC_AHB4ENR          (*(volatile U32*) (RCC_BASE_ADDR + 0xE0))

/*****
 *
 *      Masks for the peripheral enable bits
 */
#define AHB4ENR_GPIOBEN      1
#define AHB4ENR_GPIOFEN      5
#define AHB3ENR_QSPIEN       14

/*****
 *
 *      GPIO bit positions of SPI signals
 */
#define NAND_BK1_NCS_BIT      6 // Port B
#define NAND_CLK_BIT          10 // Port F
#define NAND_BK1_D0_BIT       8 // Port F
#define NAND_BK1_D1_BIT       9 // Port F
#define NAND_BK1_D2_BIT       7 // Port F
#define NAND_BK1_D3_BIT       6 // Port F

/*****
 *
 *      GPIO bits and masks
 */
#define OSPEEDR_HIGH          2uL
#define OSPEEDR_MASK          0x3uL
#define MODER_MASK            0x3uL
#define MODER_ALT              2uL
#define AFR_MASK              0xFuL

/*****
 *
 *      Quad-SPI control register
 */
#define CR_EN_BIT              0
#define CR_ABORT_BIT           1
#define CR_PRESCALER_BIT       24
#define CR_PRESCALER_MAX       255

/*****
 *
 *      Quad-SPI device configuration register
 */
#define DCR_CKMODE_BIT         0

```

```

#define DCR_FSIZE_BIT          16
#define DCR_FSIZE_MAX         0x1FuL

/*****
 *
 *      Quad-SPI status register
 */
#define SR_TEF_BIT            0
#define SR_TCF_BIT            1
#define SR_SMF_BIT            3
#define SR_TOF_BIT            4
#define SR_BUSY_BIT           5
#define SR_FLEVEL_BIT         8
#define SR_FLEVEL_MASK        0x3FuL

/*****
 *
 *      Quad-SPI communication configuration register
 */
#define CCR_INSTRUCTION_BIT    0
#define CCR_IMODE_BIT          8
#define CCR_MODE_NONE          0
#define CCR_MODE_SINGLE        1uL
#define CCR_MODE_DUAL          2uL
#define CCR_MODE_QUAD          3uL
#define CCR_ADMODE_BIT         10
#define CCR_ADSIZE_BIT         12
#define CCR_ADSIZE_MASK        0x03uL
#define CCR_ABMODE_BIT         14
#define CCR_ABSIZE_BIT         16
#define CCR_ABSIZE_MASK        0x03uL
#define CCR_DCYC_BIT           18
#define CCR_DMODE_BIT          24
#define CCR_FMODE_BIT          26
#define CCR_FMODE_WRITE        0x0uL
#define CCR_FMODE_READ         0x1uL
#define CCR_FMODE_MMAP         0x3uL
#define CCR_FMODE_MASK         0x3uL

/*****
 *
 *      Misc. defines
 */
#define NUM_BYTES_FIFO         32

/*****
 *
 *      ASSERT_IS_LOCKED
 */
#if FS_SUPPORT_TEST
    #define ASSERT_IS_LOCKED() \
        if (_LockCnt != 1) { \
            FS_X_PANIC(FS_ERRCODE_INVALID_USAGE); \
        }
#else
    #define ASSERT_IS_LOCKED()
#endif

/*****
 *
 *      IF_TEST
 */
#if FS_SUPPORT_TEST
    #define IF_TEST(Expr)      Expr
#else
    #define IF_TEST(Expr)
#endif

/*****
 *
 *      Static data
 *
 *****/
/*
 */
#if FS_SUPPORT_TEST
    static U8 _LockCnt = 0; // Just to test if the Lock()/Unlock

```

```

// function are called correctly.
#endif

/*****
 *
 *      Static code
 *
 *****/

/*****
 *
 *      _CalcClockDivider
 */
static U8 _CalcClockDivider(U32 * pFreq_Hz) {
    U8 Div;
    U32 Freq_Hz;
    U32 MaxFreq_Hz;

    Div = 0;
    MaxFreq_Hz = *pFreq_Hz;
    while (1) {
        Freq_Hz = FS_NAND_HW_PER_CLK_HZ / (Div + 1);
        if (Freq_Hz <= MaxFreq_Hz) {
            break;
        }
        ++Div;
        if (Div == CR_PRESCALER_MAX) {
            break;
        }
    }
    *pFreq_Hz = Freq_Hz;
    return Div;
}

/*****
 *
 *      _GetMode
 */
static U32 _GetMode(unsigned BusWidth, U32 NumBytes) {
    U32 Mode;

    Mode = CCR_MODE_NONE;
    if (NumBytes) {
        switch (BusWidth) {
            case 1:
                Mode = CCR_MODE_SINGLE;
                break;
            case 2:
                Mode = CCR_MODE_DUAL;
                break;
            case 4:
                Mode = CCR_MODE_QUAD;
                break;
            default:
                break;
        }
    }
    return Mode;
}

/*****
 *
 *      _GetNumCycles
 */
static U32 _GetNumCycles(unsigned BusWidth, U32 NumBytes) {
    U32 NumCycles;

    NumCycles = 0;
    if (NumBytes) {
        NumCycles = NumBytes << 3; // Assume 8-bits per byte.
        switch (BusWidth) {
            case 2:
                NumCycles >>= 1;
                break;
            case 4:

```

```

        NumCycles >>= 2;
        break;
    default:
        break;
    }
}
return NumCycles;
}

/*****
 *
 *      _ClearFlags
 */
static void _ClearFlags(void) {
    QUADSPI_FCR = 0
                | (1uL << SR_TEF_BIT)
                | (1uL << SR_TCF_BIT)
                | (1uL << SR_SMF_BIT)
                | (1uL << SR_TOF_BIT)
                ;

    //
    // Wait for the flags to be cleared.
    //
    while (1) {
        if ((QUADSPI_SR & ((1uL << SR_TEF_BIT) |
                          (1uL << SR_TCF_BIT) |
                          (1uL << SR_SMF_BIT) |
                          (1uL << SR_TOF_BIT))) == 0) {

            break;
        }
    }
}

/*****
 *
 *      Public code (via callback)
 */

/*****
 *
 *      _HW_Init
 *
 *      Function description
 *      Initializes the QSPI hardware.
 *
 *      Parameters
 *      Unit          Device index (0-based)
 *
 *      Return value
 *      Frequency of the QSPI clock in kHz.
 *
 *      Additional information
 *      _HW_Init() is mandatory and it has to be implemented by any
 *      hardware layer. The QSPI NAND physical layer calls this function
 *      first before any other function of the hardware layer. This function
 *      has to configure anything necessary for the data transfer via QSPI
 *      such as clocks, port pins, QSPI peripheral, DMA, etc.
 */
static int _HW_Init(U8 Unit) {
    U32 Div;
    U32 Freq_Hz;

    FS_USE_PARA(Unit);
    //
    // Enable the clocks of peripherals and reset them.
    //
    RCC_AHB4ENR |= 0
                | (1uL << AHB4ENR_GPIOBEN)
                | (1uL << AHB4ENR_GPIOFEN)
                ;

    RCC_AHB3ENR |= 1uL << AHB3ENR_QSPIEN;
    RCC_AHB3RSTR |= 1uL << AHB3ENR_QSPIEN;
    RCC_AHB3RSTR &= ~(1uL << AHB3ENR_QSPIEN);
    //

```

```

// Wait for the unit to exit reset.
//
while (1) {
    if ((RCC_AHB3RSTR & (1uL << AHB3ENR_QSPIEN)) == 0) {
        break;
    }
}
//
// NCS of bank 1 is an output signal and is controlled by the QUADSPI unit.
//
GPIOB_MODER  &= ~(MODER_MASK  << (NAND_BK1_NCS_BIT << 1));
GPIOB_MODER  |=  MODER_ALT    << (NAND_BK1_NCS_BIT << 1);
GPIOB_AFR_L  &= ~(AFR_MASK    << (NAND_BK1_NCS_BIT << 2));
GPIOB_AFR_L  |=  0xAuL       << (NAND_BK1_NCS_BIT << 2);
GPIOB_OSPEEDR &= ~(OSPEEDR_MASK << (NAND_BK1_NCS_BIT << 1));
GPIOB_OSPEEDR |=  OSPEEDR_HIGH << (NAND_BK1_NCS_BIT << 1);
//
// CLK is an output signal controlled by the QUADSPI unit.
//
GPIOF_MODER  &= ~(MODER_MASK  << (NAND_CLK_BIT << 1));
GPIOF_MODER  |=  MODER_ALT    << (NAND_CLK_BIT << 1);
GPIOF_AFR_H  &= ~(AFR_MASK    << ((NAND_CLK_BIT - 8) << 2));
GPIOF_AFR_H  |=  0x9uL       << ((NAND_CLK_BIT - 8) << 2);
GPIOF_OSPEEDR &= ~(OSPEEDR_MASK << (NAND_CLK_BIT << 1));
GPIOF_OSPEEDR |=  OSPEEDR_HIGH << (NAND_CLK_BIT << 1);
//
// D0 of bank 1 is an input/output signal controlled by the QUADSPI unit.
//
GPIOF_MODER  &= ~(MODER_MASK  << (NAND_BK1_D0_BIT << 1));
GPIOF_MODER  |=  MODER_ALT    << (NAND_BK1_D0_BIT << 1);
GPIOF_AFR_H  &= ~(AFR_MASK    << ((NAND_BK1_D0_BIT - 8) << 2));
GPIOF_AFR_H  |=  0xAuL       << ((NAND_BK1_D0_BIT - 8) << 2);
GPIOF_OSPEEDR &= ~(OSPEEDR_MASK << (NAND_BK1_D0_BIT << 1));
GPIOF_OSPEEDR |=  OSPEEDR_HIGH << (NAND_BK1_D0_BIT << 1);
//
// D1 of bank 1 is an input/output signal controlled by the QUADSPI unit.
//
GPIOF_MODER  &= ~(MODER_MASK  << (NAND_BK1_D1_BIT << 1));
GPIOF_MODER  |=  MODER_ALT    << (NAND_BK1_D1_BIT << 1);
GPIOF_AFR_H  &= ~(AFR_MASK    << ((NAND_BK1_D1_BIT - 8) << 2));
GPIOF_AFR_H  |=  0xAuL       << ((NAND_BK1_D1_BIT - 8) << 2);
GPIOF_OSPEEDR &= ~(OSPEEDR_MASK << (NAND_BK1_D1_BIT << 1));
GPIOF_OSPEEDR |=  OSPEEDR_HIGH << (NAND_BK1_D1_BIT << 1);
//
// D2 of bank 1 is an input/output signal and is controlled by the QUADSPI unit.
//
GPIOF_MODER  &= ~(MODER_MASK  << (NAND_BK1_D2_BIT << 1));
GPIOF_MODER  |=  MODER_ALT    << (NAND_BK1_D2_BIT << 1);
GPIOF_AFR_L  &= ~(AFR_MASK    << (NAND_BK1_D2_BIT << 2));
GPIOF_AFR_L  |=  0x9uL       << (NAND_BK1_D2_BIT << 2);
GPIOF_OSPEEDR &= ~(OSPEEDR_MASK << (NAND_BK1_D2_BIT << 1));
GPIOF_OSPEEDR |=  OSPEEDR_HIGH << (NAND_BK1_D2_BIT << 1);
//
// D3 of bank 1 is an output signal and is controlled by the QUADSPI unit.
//
GPIOF_MODER  &= ~(MODER_MASK  << (NAND_BK1_D3_BIT << 1));
GPIOF_MODER  |=  MODER_ALT    << (NAND_BK1_D3_BIT << 1);
GPIOF_AFR_L  &= ~(AFR_MASK    << (NAND_BK1_D3_BIT << 2));
GPIOF_AFR_L  |=  0x9uL       << (NAND_BK1_D3_BIT << 2);
GPIOF_OSPEEDR &= ~(OSPEEDR_MASK << (NAND_BK1_D3_BIT << 1));
GPIOF_OSPEEDR |=  OSPEEDR_HIGH << (NAND_BK1_D3_BIT << 1);
//
// Initialize the Quad-SPI controller.
//
Freq_Hz = FS_NAND_HW_NAND_CLK_HZ;
Div = (U32)_CalcClockDivider(&Freq_Hz);
QUADSPI_CR = 0
    | (1uL << CR_EN_BIT) // Enable the Quad-SPI unit.
    | (Div << CR_PRESCALER_BIT)
    ;
QUADSPI_DCR = 0
    | (1uL << DCR_CKMODE_BIT) // CLK signal stays HIGH
    // when the NAND flash is not selected.
    | (DCR_FSIZE_MAX << DCR_FSIZE_BIT) // We set the NAND flash size to maximum
    // since the actual value is not known
    // at this stage.

```

```

        ;
    return (int)Freq_Hz / 1000;
}

/*****
 *
 *      _HW_ExecCmd
 *
 * Function description
 * Executes a NAND flash command without data transfer.
 *
 * Parameters
 * Unit          Device index (0-based)
 * Cmd           Code of the command to be sent.
 * BusWidth     Number of data lines to be used for sending
 *              the command code.
 *
 * Return value
 * ==0          OK, command sent.
 * !=0          An error occurred.
 *
 * Additional information
 * This function is mandatory and it has to be implemented by any
 * hardware layer.
 */
static int _HW_ExecCmd(U8 Unit, U8 Cmd, U8 BusWidth) {
    U32 CfgReg;
    U32 CmdMode;

    ASSERT_IS_LOCKED();
    FS_USE_PARA(Unit); // This device has only one HW unit.
    //
    // Fill local variables.
    //
    CmdMode = _GetMode(BusWidth, sizeof(Cmd));
    CfgReg = 0
            | (CCR_FMODE_WRITE << CCR_FMODE_BIT)
            | (CmdMode << CCR_IMODE_BIT)
            | (Cmd << CCR_INTRUCTION_BIT)
            ;

    //
    // Wait until the unit is ready for the new command.
    //
    while (1) {
        if ((QUADSPI_SR & (1uL << SR_BUSY_BIT)) == 0) {
            break;
        }
    }
    //
    // Execute the command.
    //
    QUADSPI_DLR = 0;
    QUADSPI_ABR = 0;
    QUADSPI_CCR = CfgReg;
    //
    // Wait until the command has been completed.
    //
    while (1) {
        if ((QUADSPI_SR & (1uL << SR_BUSY_BIT)) == 0) {
            break;
        }
    }
    return 0;
}

/*****
 *
 *      _HW_ReadData
 *
 * Function description
 * Transfers data from NAND flash device to MCU.
 *
 * Parameters
 * Unit          Device index (0-based)
 * Cmd           Code of the command to be sent.
 * pPara        Additional command parameters (can be NULL).
 */

```

```

*   NumBytesPara   Number of additional bytes to be sent after command.
*                 Can be 0 if pPara is NULL.
*   NumBytesAddr   Number of address bytes to be sent.
*                 Can be 0 if pPara is NULL.
*   pData          Data received from the NAND flash device.
*   NumBytesData   Number of bytes to be received from the NAND flash device.
*   BusWidth       Specifies the number of data lines to be used
*                 during the data transfer.
*
* Return value
*   ==0           OK, data transferred.
*   !=0           An error occurred.
*
* Additional information
*   This function is mandatory and it has to be implemented by any
*   hardware layer.
*/
static int _HW_ReadData(U8 Unit, U8 Cmd, const U8 * pPara, unsigned NumBytesPara,
                      unsigned NumBytesAddr, U8 * pData, unsigned NumBytesData,
                      U16 BusWidth) {

    U32 AddrReg;
    U32 AltReg;
    U32 CfgReg;
    U32 DataMode;
    U32 AddrMode;
    U32 CmdMode;
    U32 DataReg;
    U32 NumCyclesDummy;
    U32 AddrSize;
    U32 NumBytesAvail;
    U32 NumBytes;
    U32 NumBytesDummy;

    ASSERT_IS_LOCKED();
    FS_USE_PARA(Unit); // This device has only one HW unit.
    //
    // Fill local variables.
    //
    AddrReg      = 0;
    AltReg       = 0;
    NumBytesDummy = NumBytesPara - NumBytesAddr;
    CmdMode      = _GetMode(FS_BUSWIDTH_GET_CMD(BusWidth), sizeof(Cmd));
    AddrMode     = _GetMode(FS_BUSWIDTH_GET_ADDR(BusWidth), NumBytesAddr);
    NumCyclesDummy = _GetNumCycles(FS_BUSWIDTH_GET_ADDR(BusWidth), NumBytesDummy);
    // The dummy bytes are sent using the address bus mode.
    DataMode     = _GetMode(FS_BUSWIDTH_GET_DATA(BusWidth), NumBytesData);
    //
    // Encode the address.
    //
    if (NumBytesAddr) {
        NumBytes = NumBytesAddr;
        do {
            AddrReg <<= 8;
            AddrReg |= (U32)(*pPara++);
        } while (--NumBytes);
    }
    AddrSize = 0;
    if (NumBytesAddr) {
        AddrSize = (NumBytesAddr - 1) & CCR_ADSIZE_MASK;
    }
    CfgReg = 0
        | (CCR_FMODE_READ << CCR_FMODE_BIT)
        | (DataMode << CCR_DMODE_BIT)
        | (NumCyclesDummy << CCR_DCYC_BIT)
        | (AddrSize << CCR_ADSIZE_BIT)
        | (AddrMode << CCR_ADMODE_BIT)
        | (CmdMode << CCR_IMODE_BIT)
        | (Cmd << CCR_INTRUCTION_BIT)
        ;

    //
    // Wait until the unit is ready for the new command.
    //
    while (1) {
        if ((QUADSPI_SR & (1uL << SR_BUSY_BIT)) == 0) {
            break;
        }
    }
}

```



```

}
//
// Execute the command.
//
_ClearFlags();
if (NumBytesData) {
    QUADSPI_DLR = NumBytesData - 1; // 0 means "read 1 byte".
}
QUADSPI_ABR = AltReg;
QUADSPI_CCR = CfgReg;
if (NumBytesAddr) {
    QUADSPI_AR = AddrReg;
}
//
// Read data from NOR flash.
//
if (NumBytesData) {
    do {
        //
        // Wait for the data to be received.
        //
        while (1) {
            NumBytesAvail = (QUADSPI_SR >> SR_FLEVEL_BIT) & SR_FLEVEL_MASK;
            if ((NumBytesAvail >= 4) || (NumBytesAvail >= NumBytesData)) {
                break;
            }
        }
        //
        // Read data and store it to destination buffer.
        //
        if (NumBytesData < 4) {
            //
            // Read single bytes.
            //
            do {
                *pData++ = QUADSPI_DR_BYTE;
            } while (--NumBytesData);
        } else {
            //
            // Read 4 bytes at a time.
            //
            DataReg = QUADSPI_DR;
            *pData++ = (U8)DataReg;
            *pData++ = (U8)(DataReg >> 8);
            *pData++ = (U8)(DataReg >> 16);
            *pData++ = (U8)(DataReg >> 24);
            NumBytesData -= 4;
        }
    } while (NumBytesData);
}
//
// Wait until the data transfer has been completed.
//
while (1) {
    if (QUADSPI_SR & (1uL << SR_TCF_BIT)) {
        break;
    }
}
return 0;
}

/*****
*
*     _HW_WriteData
*
* Function description
*     Transfers data from MCU to NAND flash device.
*
* Parameters
*     Unit           Device index (0-based)
*     Cmd            Code of the command to be sent.
*     pPara          Additional command parameters (can be NULL).
*     NumBytesPara   Number of additional bytes to be sent after command.
*                   Can be 0 if pPara is NULL.
*     NumBytesAddr   Number of address bytes to be sent.
*                   Can be 0 if pPara is NULL.
*
*****/

```

```

*   pData          Data to be sent to NAND flash device.
*   NumBytesData   Number of data bytes to be sent to NAND flash device.
*   BusWidth       Specifies the number of data lines to be used
*                  during the data transfer.
*
* Return value
*   ==0           OK, data transferred.
*   !=0           An error occurred.
*
* Additional information
*   This function is mandatory and it has to be implemented by any
*   hardware layer.
*/
static int _HW_WriteData(U8 Unit, U8 Cmd, const U8 * pPara, unsigned NumBytesPara,
                        unsigned NumBytesAddr, const U8 * pData, unsigned NumBytesData,
                        U16 BusWidth) {

    U32 AddrReg;
    U32 AltReg;
    U32 CfgReg;
    U32 DataMode;
    U32 AddrMode;
    U32 CmdMode;
    U32 DataReg;
    U32 AddrSize;
    U32 NumCyclesDummy;
    U32 NumBytes;
    U32 NumBytesDummy;
    U32 NumBytesFree;

    ASSERT_IS_LOCKED();
    FS_USE_PARA(Unit); // This device has only one HW unit.
    //
    // Fill local variables.
    //
    AddrReg      = 0;
    AltReg       = 0;
    NumBytesDummy = NumBytesPara - NumBytesAddr;
    CmdMode      = _GetMode(FS_BUSWIDTH_GET_CMD(BusWidth), sizeof(Cmd));
    AddrMode     = _GetMode(FS_BUSWIDTH_GET_ADDR(BusWidth), NumBytesAddr);
    NumCyclesDummy = _GetNumCycles(FS_BUSWIDTH_GET_ADDR(BusWidth), NumBytesDummy);
    // The dummy bytes are sent using the address bus mode.
    DataMode     = _GetMode(FS_BUSWIDTH_GET_DATA(BusWidth), NumBytesData);
    //
    // Encode the address.
    //
    if (NumBytesAddr) {
        NumBytes = NumBytesAddr;
        do {
            AddrReg <<= 8;
            AddrReg |= (U32)(*pPara++);
        } while (--NumBytes);
    }
    AddrSize = 0;
    if (NumBytesAddr) {
        AddrSize = NumBytesAddr - 1;
    }
    CfgReg = 0
        | (CCR_FMODE_WRITE << CCR_FMODE_BIT)
        | (DataMode << CCR_DMODE_BIT)
        | (NumCyclesDummy << CCR_DCYC_BIT)
        | (AddrSize << CCR_ADSIZE_BIT)
        | (AddrMode << CCR_ADMODE_BIT)
        | (CmdMode << CCR_IMODE_BIT)
        | (Cmd << CCR_INSTRUCTION_BIT)
        ;

    //
    // Wait until the unit is ready for the new command.
    //
    while (1) {
        if ((QUADSPI_SR & (1uL << SR_BUSY_BIT)) == 0) {
            break;
        }
    }
    //
    // Execute the command.
    //

```

```

_ClearFlags();
if (NumBytesData) {
    QUADSPI_DLR = NumBytesData - 1;    // 0 means "read 1 byte".
}
QUADSPI_ABR = AltReg;
QUADSPI_CCR = CfgReg;
if (NumBytesAddr) {
    QUADSPI_AR = AddrReg;
}
//
// write data to NOR flash.
//
if (NumBytesData) {
    do {
        //
        // Wait for free space in FIFO.
        //
        while (1) {
            NumBytesFree = (QUADSPI_SR >> SR_FLEVEL_BIT) & SR_FLEVEL_MASK;
            NumBytesFree = NUM_BYTES_FIFO - NumBytesFree;
            if ((NumBytesFree >= 4) || (NumBytesFree >= NumBytesData)) {
                break;
            }
        }
        //
        // Get the data from source buffer and write it.
        //
        if (NumBytesData < 4) {
            //
            // Write single bytes.
            //
            do {
                QUADSPI_DR_BYTE = *pData++;
            } while (--NumBytesData);
        } else {
            //
            // Write 4 bytes at a time if possible.
            //
            DataReg = (U32)*pData++;
            DataReg |= (U32)*pData++ << 8;
            DataReg |= (U32)*pData++ << 16;
            DataReg |= (U32)*pData++ << 24;
            NumBytesData -= 4;
            QUADSPI_DR = DataReg;
        }
    } while (NumBytesData);
}
//
// Wait until the data transfer has been completed.
//
while (1) {
    if (QUADSPI_SR & (1uL << SR_TCF_BIT)) {
        break;
    }
}
return 0;
}

/*****
*
*   _HW_Delay
*
*   Function description
*   Blocks the execution for the specified number of milliseconds.
*
*   Parameters
*   Unit           Device index (0-based)
*   ms             Number of milliseconds to wait.
*
*   Additional information
*   This function is mandatory and it has to be implemented by any
*   hardware layer.
*/
static void _HW_Delay(U8 Unit, int ms) {
    FS_USE_PARA(Unit);
    if (ms) {

```

```

volatile U32 NumCycles;

do {
    NumCycles = FS_NAND_HW_CYCLES_PER_MS;
    do {
        ;
    } while (--NumCycles);
} while (--ms);
}
}

/*****
*
*     _HW_Poll
*
* Function description
* Sends a command repeatedly and checks the response data
* for a specified condition.
*
* Parameters
* Unit          Device index (0-based)
* Cmd           Code of the command to be sent.
* pPara        Additional command parameters (can be NULL).
* NumBytesPara Number of additional bytes to be sent after command.
*              Can be 0 if pPara is NULL.
* BitPos       Position of the bit inside response data that has
*              to be checked (0-based, with 0 being LSB)
* BitValue     Bit value to wait for.
* Delay_ms     Time between two command executions.
* TimeOut_ms   Maximum time to wait for the bit at BitPos to be set to BitValue.
* BusWidth     Specifies how many data lines have to be used for sending
*              the command and parameters and for reading the data.
*
* Return value
* > 0         Error, timeout occurred.
* ==0         OK, bit set to specified value.
* < 0         Error, feature not supported.
*
* Additional information
* This function is optional and it can be left unimplemented
* or set to NULL in the structure of the hardware layer below.
*/
static int _HW_Poll(U8 Unit, U8 Cmd, const U8 * pPara, unsigned NumBytesPara,
                  U8 BitPos, U8 BitValue, U32 Delay_ms, U32 TimeOut_ms, U16 BusWidth) {
    FS_USE_PARA(Unit);
    FS_USE_PARA(Cmd);
    FS_USE_PARA(pPara);
    FS_USE_PARA(NumBytesPara);
    FS_USE_PARA(BitPos);
    FS_USE_PARA(BitValue);
    FS_USE_PARA(Delay_ms);
    FS_USE_PARA(TimeOut_ms);
    FS_USE_PARA(BusWidth);
    return -1;
}

/*****
*
*     _HW_Lock
*
* Function description
* Requests exclusive access to SPI bus.
*
* Parameters
* Unit          Device index (0-based)
*
* Additional information
* This function is optional and it can be left unimplemented
* or set to NULL in the structure of the hardware layer below.
*/
static void _HW_Lock(U8 Unit) {
    FS_USE_PARA(Unit);
    IF_TEST(_LockCnt++);
    ASSERT_IS_LOCKED();
}

```

```

/*****
 *
 *      _HW_Unlock
 *
 * Function description
 *      Releases the exclusive access of SPI bus.
 *
 * Parameters
 *      Unit      Device index (0-based)
 *
 * Additional information
 *      This function is optional and it can be left unimplemented
 *      or set to NULL in the structure of the hardware layer below.
 */
static void _HW_Unlock(U8 Unit) {
    FS_USE_PARA(Unit);
    ASSERT_IS_LOCKED();
    IF_TEST(_LockCnt--);
}

/*****
 *
 *      Public const
 *
 *****/

/*****
 *
 *      FS_NAND_HW_QSPI_STM32H743_SEGGER_QSPI_Flash_Evaluator
 */
const FS_NAND_HW_TYPE_QSPI FS_NAND_HW_QSPI_STM32H743_SEGGER_QSPI_Flash_Evaluator = {
    _HW_Init,
    _HW_ExecCmd,
    _HW_ReadData,
    _HW_WriteData,
    _HW_Poll,
    _HW_Delay,
    _HW_Lock,
    _HW_Unlock
};

/***** End of file *****/

```

6.3.5.6 Hardware layer API - FS_NAND_HW_TYPE_SPI

This hardware layer supports any serial NAND flash device with a standard SPI. It is used by the `FS_NAND_PHY_SPI` physical layer to exchange data with a NAND flash device that supports such an interface. Typically, the implementation of `FS_NAND_HW_TYPE_SPI` hardware layer makes use of a SPI controller. It is also possible to implement the data exchange via GPIO pins.

The functions of this hardware layer are grouped in the structure of type `FS_NAND_HW_TYPE_SPI`. The following sections describe these functions in detail.

6.3.5.6.1 FS_NAND_HW_TYPE_SPI

Description

NAND hardware layer API for NAND flash devices connected via SPI.

Type definition

```
typedef struct {
    FS_NAND_HW_TYPE_SPI_INIT          * pfInit;
    FS_NAND_HW_TYPE_SPI_DISABLE_CS   * pfDisableCS;
    FS_NAND_HW_TYPE_SPI_ENABLE_CS    * pfEnableCS;
    FS_NAND_HW_TYPE_SPI_DELAY        * pfDelay;
    FS_NAND_HW_TYPE_SPI_READ         * pfRead;
    FS_NAND_HW_TYPE_SPI_WRITE        * pfWrite;
    FS_NAND_HW_TYPE_SPI_LOCK         * pfLock;
    FS_NAND_HW_TYPE_SPI_UNLOCK       * pfUnlock;
} FS_NAND_HW_TYPE_SPI;
```

Structure members

Member	Description
pfInit	Initializes the hardware.
pfDisableCS	Disables the NAND flash device.
pfEnableCS	Enables the NAND flash device.
pfDelay	Block the execution for a specified number of milliseconds.
pfRead	Transfers a specified number of bytes from NAND flash device to MCU.
pfWrite	Transfers a specified number of bytes from MCU to NAND flash device.
pfLock	Request exclusive access to SPI bus.
pfUnlock	Releases the exclusive access to SPI bus.

6.3.5.6.2 FS_NAND_HW_TYPE_SPI_INIT

Description

Initializes the hardware.

Type definition

```
typedef int FS_NAND_HW_TYPE_SPI_INIT(U8 Unit);
```

Parameters

Parameter	Description
<code>Unit</code>	Index of the NAND hardware layer instance (0-based)

Return value

≠ 0 OK, frequency of the SPI clock in kHz.
= 0 An error occurred.

Additional information

This function is a member of the `FS_NAND_HW_TYPE_SPI` NAND hardware layer API. It is mandatory to be implemented by all the NAND hardware layers of this type. `FS_NAND_HW_TYPE_SPI_INIT` is the first function of the hardware layer API that is called by a NAND physical layer during the mounting of the file system.

This function has to perform any initialization of the MCU hardware required to access the NAND flash device such as clocks, port pins, SPI controllers, etc.

A serial NAND flash requires that the SPI communication protocol meets the following requirements:

- 8-bit data length.
- The most significant bit has to be sent out first.
- Chip Select (CS) signal should be initially high to disable the serial NAND flash device.
- The SPI clock frequency does not have to exceed the maximum clock frequency that is specified by the serial NAND flash device.

Typically, two SPI modes are supported:

- Mode 0 - CPOL = 0, CPHA = 0, SPI clock remains low in idle state.
- Mode 3 - CPOL = 1, CPHA = 1, SPI clock remains high in idle state.

6.3.5.6.3 FS_NAND_HW_TYPE_SPI_DISABLE_CS

Description

Disables the NAND flash device.

Type definition

```
typedef void FS_NAND_HW_TYPE_SPI_DISABLE_CS(U8 Unit);
```

Parameters

Parameter	Description
<code>Unit</code>	Index of the NAND hardware layer instance (0-based)

Additional information

This function is a member of the `FS_NAND_HW_TYPE_SPI` NAND hardware layer API. It is mandatory to be implemented by all the NAND hardware layers of this type.

The NAND flash device is disabled by driving the Chip Select (CS) signal to logic-high. The NAND flash device ignores any command or data sent with the CS signal set to logic-high.

6.3.5.6.4 FS_NAND_HW_TYPE_SPI_ENABLE_CS

Description

Enables the NAND flash device.

Type definition

```
typedef void FS_NAND_HW_TYPE_SPI_ENABLE_CS(U8 Unit);
```

Parameters

Parameter	Description
Unit	Index of the NAND hardware layer instance (0-based)

Additional information

This function is a member of the `FS_NAND_HW_TYPE_SPI` NAND hardware layer API. It is mandatory to be implemented by all the NAND hardware layers of this type.

The NAND flash device is enabled by driving the Chip Select (CS) signal to logic low state. Typically, the NAND flash device is enabled at the beginning of command and data sequence and disabled at the end of it.

6.3.5.6.5 FS_NAND_HW_TYPE_SPI_DELAY

Description

Blocks the execution for the specified number of milliseconds.

Type definition

```
typedef void FS_NAND_HW_TYPE_SPI_DELAY(U8 Unit,  
                                       int ms);
```

Parameters

Parameter	Description
<code>Unit</code>	Index of the NAND hardware layer instance (0-based)
<code>ms</code>	Number of milliseconds to wait.

Additional information

This function is a member of the `FS_NAND_HW_TYPE_SPI` NAND hardware layer API. It is mandatory to be implemented by all the NAND hardware layers of this type.

The time `FS_NAND_HW_TYPE_SPI_DELAY` blocks does not have to be accurate. That is the function can block the execution longer than the number of specified milliseconds but no less than that.

6.3.5.6.6 FS_NAND_HW_TYPE_SPI_READ

Description

Transfers a specified number of bytes from NAND flash device to MCU.

Type definition

```
typedef int FS_NAND_HW_TYPE_SPI_READ(U8      Unit,
                                     void    * pData,
                                     unsigned NumBytes);
```

Parameters

Parameter	Description
<code>Unit</code>	Index of the NAND hardware layer instance (0-based)
<code>pData</code>	Data read from NAND flash device.
<code>NumBytes</code>	Number of bytes to be read.

Return value

= 0 OK, data read successfully.
 ≠ 0 An error occurred.

Additional information

This function is a member of the `FS_NAND_HW_TYPE_SPI` NAND hardware layer API. It is mandatory to be implemented by all the NAND hardware layers of this type.

The function has to sample the data on the falling edge of the SPI clock.

6.3.5.6.7 FS_NAND_HW_TYPE_SPI_WRITE

Description

Transfers a specified number of bytes from MCU to NAND flash device.

Type definition

```
typedef int FS_NAND_HW_TYPE_SPI_WRITE(      U8      Unit,
                                             const void * pData,
                                             unsigned NumBytes);
```

Parameters

Parameter	Description
<code>Unit</code>	Index of the NAND hardware layer instance (0-based)
<code>pData</code>	in Data to be written to NAND flash device.
<code>NumBytes</code>	Number of bytes to be written.

Return value

= 0 OK, data written successfully.
 ≠ 0 An error occurred.

Additional information

This function is a member of the `FS_NAND_HW_TYPE_SPI` NAND hardware layer API. It is mandatory to be implemented by all the NAND hardware layers of this type.

The NAND flash device samples the data on the rising edge of the SPI clock.

6.3.5.6.8 FS_NAND_HW_TYPE_SPI_LOCK

Description

Requests exclusive access to SPI bus.

Type definition

```
typedef void FS_NAND_HW_TYPE_SPI_LOCK(U8 Unit);
```

Parameters

Parameter	Description
<code>Unit</code>	Index of the NAND hardware layer instance (0-based)

Additional information

This function is a member of the `FS_NAND_HW_TYPE_SPI` NAND hardware layer API. The implementation of this function is optional.

The `FS_NAND_PHY_SPI` physical layer calls this function to indicate that it needs exclusive to access the serial NAND flash device via the SPI bus. It is guaranteed that the `FS_NAND_PHY_SPI` physical layer does not attempt to exchange any data with the serial NAND flash device via the SPI bus before calling this function first. It is also guaranteed that `FS_NAND_HW_TYPE_SPI_LOCK` and `FS_NAND_HW_TYPE_SPI_UNLOCK` are called in pairs. Typically, this function is used for synchronizing the access to SPI bus when the SPI bus is shared between the serial NAND flash and other SPI devices.

A possible implementation would make use of an OS semaphore that is acquired in `FS_NAND_HW_TYPE_SPI_LOCK` and released in `FS_NAND_HW_TYPE_SPI_UNLOCK`.

6.3.5.6.9 FS_NAND_HW_TYPE_SPI_UNLOCK

Description

Releases the exclusive access of SPI bus.

Type definition

```
typedef void FS_NAND_HW_TYPE_SPI_UNLOCK(U8 Unit);
```

Parameters

Parameter	Description
<code>Unit</code>	Index of the NAND hardware layer instance (0-based)

Additional information

This function is a member of the `FS_NAND_HW_TYPE_SPI` NAND hardware layer API. The implementation of this function is optional.

The `FS_NAND_PHY_SPI` physical layer calls this function after it no longer needs to access the serial NAND flash device via the SPI bus. It is guaranteed that the `FS_NAND_PHY_SPI` physical layer does not attempt to exchange any data with the serial NAND flash device via the SPI bus before calling `FS_NAND_HW_TYPE_SPI_LOCK`. It is also guaranteed that `FS_NAND_HW_TYPE_SPI_UNLOCK` and `FS_NAND_HW_TYPE_SPI_LOCK` are called in pairs.

`FS_NAND_HW_TYPE_SPI_UNLOCK` and `FS_NAND_HW_TYPE_SPI_LOCK` can be used to synchronize the access to the SPI bus when other devices than the serial NAND flash are connected to it. A possible implementation would make use of an OS semaphore that is acquired `FS_NAND_HW_TYPE_SPI_LOCK` and released in `FS_NAND_HW_TYPE_SPI_UNLOCK`.

6.3.6 Test hardware

The SEGGER NAND-Flash EVAL board is an easy to use and cost effective testing tool designed to evaluate the features and the performance of the emFile NAND driver. The NAND driver can be used with emFile or emUSB-Device, in which case the board behaves like a mass storage device (USB drive). Common evaluation boards are usually used to perform these tests but this approach brings several disadvantages. Software and hardware development tools are required to build and load the application into the target system. Moreover, the tests are restricted to the type of NAND flash which is soldered on the board. The NAND-Flash EVAL board was designed to overcome these limitations and provides the user with an affordable alternative. The main feature is that the NAND flash is not directly soldered on the board. A 48-pin TSOP socket is used instead which allows the user to experiment with different types of NAND flashes. This helps finding the right NAND flash for an application and thus reducing costs. A further important feature is that the NAND-Flash EVAL board comes preloaded with a USB-MSD application. When connected to a PC over USB, the board shows up as a removable storage on the host operating system. Performance and functionality tests of NAND flash can thus be performed without the need of an expensive development environment. All current operating systems will recognize the board out of the box.

The NAND-Flash EVAL board comes with a ready to use USB-MSD application in binary form. emFile is provided in object code{c} form together with a start project which can be easily modified to create custom applications. For programming and debugging a JTAG debug probe like J-Link is required. The package also contains the schematics of the board.

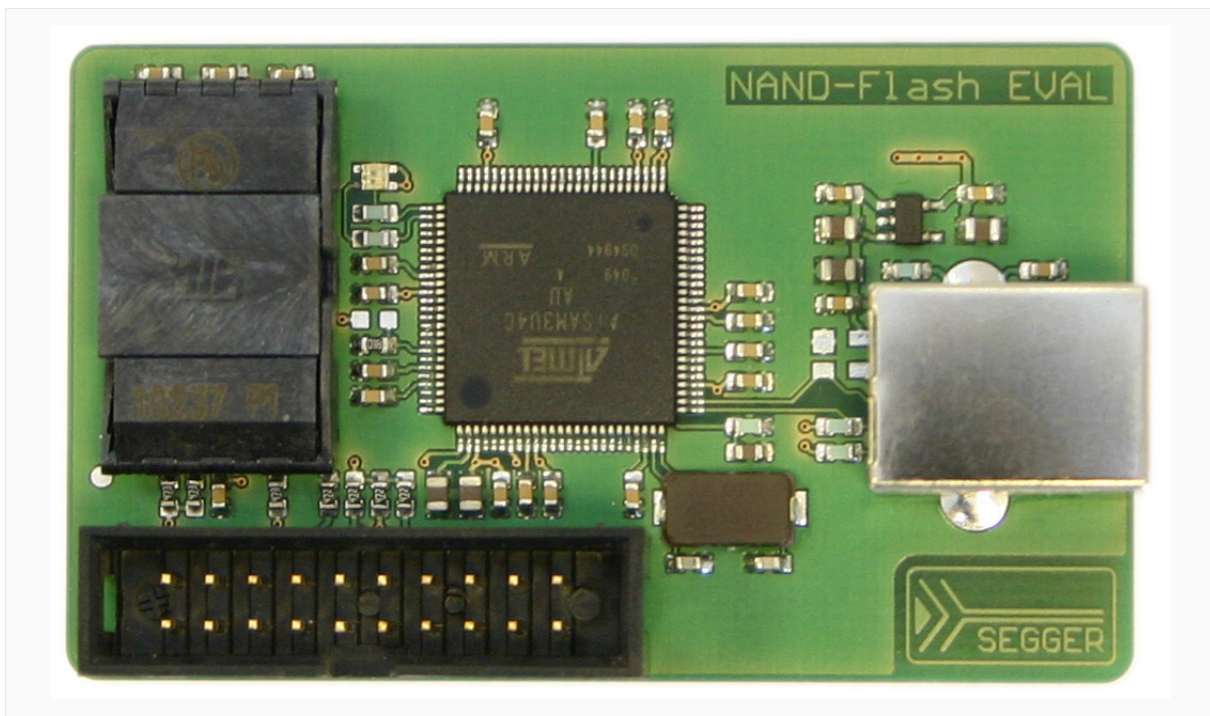

NAND-Flash EVAL

Feature list

- Atmel ATSAM3U4C ARM Cortex-M3 microcontroller
- NAND flash socket
- 2 color LED
- 20-pin JTAG header
- High speed USB interface

6.3.7 FAQs

Q: Are Multi-Level Cell NAND flashes (MLCs) supported?

A: Yes, the Universal NAND driver supports MLCs.

Q: Are NAND flash devices with 4 Kbyte pages supported?

A: Yes, they are supported via the `FS_NAND_PHY_4096x8` and `FS_NAND_PHY_ONFI` physical layers.

6.4 NOR flash driver

6.4.1 General information

emFile supports the use of unmanaged NOR flash devices as data storage. Two drivers for NOR flash devices also known as flash translation layers are provided:

- Sector Map NOR driver - Supports almost any parallel or serial NOR flash device. This driver was optimized for increase write performance.
- Block Map NOR driver - Supports almost any parallel or serial NOR flash device. This driver was optimized for reduced RAM usage. The difference between the two NOR drivers consists in the way they are managing the mapping of file system logical sectors to the NOR flash device. The Sector map driver was designed with the goal to access the data fast at a time when NOR flash devices had a relatively small capacity (a few Mbytes). To achieve this, the driver maintains a mapping table at logical sector granularity. This approach has proven to be very efficient, but for modern NOR flash devices with capacities larger than 8 Mbytes the RAM usage of the Sector Map NOR driver becomes increasingly high. This is the reason why the Block Map NOR driver was developed. The design goal of the Block Map NOR driver was to use as few RAM as possible. This is realized, by mapping blocks of file system logical sectors to NOR flash device.

6.4.1.1 Software structure

The NOR drivers are organized into different layers that contain from top to bottom:

- NOR driver layer
- *NOR physical layer*
- *NOR hardware layer*

A hardware layer is required only for serial NOR flash devices. Typically, CFI compliant NOR flash device is mapped into the system memory of the MCU and can be accessed directly without a hardware layer. Normally no changes to the physical layer are required. If the physical layer needs to be adapted, a template is provided.

6.4.1.2 Garbage collection

The driver performs the garbage collection automatically during the write operations. If no empty logical sectors are available to store the data, new empty logical sectors are created by erasing the data of the logical sectors marked as invalid. This involves a NOR physical sector erase operation which, depending on the characteristics of the NOR flash, can potentially take a long time to complete, and therefore reduces the write performance. For applications which require maximum write throughput, the garbage collection can be done in the application. Typically, this operation can be performed when the file system is idle. Two API functions are provided: `FS_STORAGE_Clean()` and `FS_STORAGE_CleanOne()`. They can be called directly from the task which is performing the write or from a background task. The `FS_STORAGE_Clean()` function blocks until all the invalid logical sectors are converted to free logical sectors. A write operation following the call to this function runs at maximum speed. The other function, `FS_STORAGE_CleanOne()`, converts the invalid sectors of a single physical sector. Depending on the number of invalid logical sectors, several calls to this function are required to clean up the entire storage device.

6.4.1.3 Fail-safe operation

The operation of emFile NOR driver is fail-safe. This means that the driver performs only atomic operations in order to make sure that the stored data is always valid after an unexpected power failure that interrupts a write operation. If the unexpected power failure interrupts the write operation, then the old version of the modified data is preserved.

The fail-safe operation is only guaranteed if the NOR flash device is able to fully complete the last write operation that it receives from the file system before the unexpected power failure. This means that the supply voltage of the NOR flash device has to remain valid for a sufficiently long time after the MCU enters reset (typically few hundreds of microseconds)

to allow the NOR flash device to complete that write operation. The exact timing can be taken from the data sheet of the NOR flash device.

The number of bytes written by the NOR driver in one write operation varies between the value configured via `FS_NOR_LINE_SIZE` and the page size of the NOR flash device. Not all the data the NOR driver writes to the storage is critical. Non-critical write operations can be interrupted by an unexpected power failure without negatively affecting the fail-safe operation. The critical data is always stored as a write operation containing `FS_NOR_LINE_SIZE` bytes. This type of write operations have to be completed by the NOR flash device and cannot be interrupted.

The erase operation of a NOR flash sector can be interrupted by an unexpected power failure because the NOR driver is able to determine at low-level mount which NOR flash sector was not completely erased. The incompletely erased NOR flash sectors will be erased again when required.

The above requirements for the write operation do not apply for configurations that use the Block Map NOR driver with the CRC verification enabled because in this configuration the file system is able to determine and discard incomplete write operations at low-level mount. However, the retention time of the data written during the interrupted operation can no longer be guaranteed.

6.4.1.4 Wear leveling

Wear leveling is supported by both NOR drivers. The wear leveling procedure makes sure that the number of erase cycles remains approximately equal for each physical sector. This works by keeping track of the index of the last erased physical sector. When a new erased physical sector is required to store data then the first free physical sector with an index greater than the last one is selected. The index of the physical sector wraps around when the end of the NOR flash device is reached. In addition, the wear leveling procedure keeps a count of the number of times each physical sector has been erased called erase count that is stored on the NOR flash device. The erase count is used to make sure that physical sectors that store data that is rarely modified are also equally erased. For this purpose the wear leveling procedure calculates the difference between the erase counts of the selected physical sector and of the physical sector with the smallest erase count. If the calculated difference is greater than the value specified via `FS_NOR_MAX_ERASE_CNT_DIFF` or `FS_NOR_BM_SetMaxEraseCntDiff()` then the physical sector with the smaller erase count is used instead.

6.4.1.5 Low-level format

Before using a NOR flash device for the first time, the application has to initialize it by performing a low-level format operation on it. Refer to `FS_FormatLow()` and `FS_FormatLLIfRequired()` for detailed information about this.

6.4.1.6 CRC verification

The integrity of the data stored to a NOR flash device using the Block Map NOR driver can be increased by enabling the CRC verification feature. With the CRC verification feature enabled the Block Map NOR driver calculates a checksum of payload and management data that is written to NOR flash device using a CRC (Cyclic Redundancy Check) algorithm. The calculated checksum is stored together with the payload and management data to NOR flash device. Each time the Block Map NOR driver reads some data from the NOR flash device it also calculates the checksum of it using the same algorithm. The calculated checksum is then compared with the checksum read from NOR flash device and if a mismatch occurs an error is reported to the application via the return value of the called API function as well as via the callback registered using `FS_NOR_BM_SetOnFatalErrorCallback()`. Depending on what data was exactly damaged an error recovery may be possible or not. The application may try to repair the damaged data by running a disk checking operation via `FS_CheckDisk()`.

The CRC verification is disabled by default and has to be enabled at compile time as well as at runtime. `FS_NOR_SUPPORT_CRC` has to be set to 1 in order to enable the support for CRC verification at compile time. At runtime `FS_NOR_BM_EnableCRC()` has to be called in

`FS_X_AddDevices()` to activate the CRC verification feature. By default, the Block Map NOR driver uses the internal CRC calculation routines of the file system but the application can register its own CRC calculation routines via `FS_NOR_BM_SetCRCHook()`.

6.4.1.7 Bit error correction

The integrity of the data stored to a NOR flash device using the Block Map NOR driver can be increased by enabling the bit error correction. With the bit error correction feature enabled the Block Map NOR driver calculates a parity check of payload and management data that is written to NOR flash device using an error correction algorithm. The calculated parity check is stored together with the payload and management data to NOR flash device. Each time the Block Map NOR driver reads some data from the NOR flash device it uses the same error correction algorithm and read parity check to verify if any bit errors occurred and if so to correct them. If the algorithm is not able to correct the bit errors than an error is reported to the application via the return value of the called API function as well as via the callback registered using `FS_NOR_BM_SetOnFatalErrorCallback()`. Depending on what data was exactly damaged an error recovery may be possible or not. The application may try to repair the damaged data by running a disk checking operation via `FS_CheckDisk()`. The bit error correction is disabled by default and has to be enabled at compile time as well as at runtime. `FS_NOR_SUPPORT_ECC` has to be set to 1 in order to enable the support for bit error correction at compile time. At runtime `FS_NOR_BM_EnableECC()` has to be called in `FS_X_AddDevices()` to activate the bit error correction feature. By default, the Block Map NOR driver uses an error correction algorithm that is able to correct 1 bit error and to detect 2 bit errors in the management and payload data of the file system but the application can register its own bit error correction routines via `FS_NOR_BM_SetECCHook()`.

6.4.1.8 Supported hardware

The NOR flash drivers can be used with almost any NOR flash device. This includes NOR flash device with 8-bit and 16-bit parallel interfaces, as well as two 16-bit interfaces in parallel. Serial NOR flash devices are also supported. A NOR flash device has to meet the following requirements:

- The NOR flash device has to contain a minimum of two physical sectors. The physical sectors do not need to be of equal size but at least two physical sectors of each size must exist. For example a NOR flash device 11 physical sectors organized as 8 * 8 Kbytes + 3 * 64 Kbytes is supported.
- All the physical sectors need to be at least 2048 bytes large.
- The erase operation must set all bits in a physical sector to one.

In order to provide the best write performance, the NOR drivers make use of a NOR flash device feature that permits the same location to be modified multiple times without an erase operation in between, as long as only bits set to 1 are changed to 0. For NOR flash devices that do not support this feature, the NOR drivers have to be compiled with the configuration define `FS_NOR_CAN_REWRITE` set to 0.

In general, the NOR drivers support almost all serial and parallel NOR flashes which meet the listed requirements. In addition, the NOR drivers can use the internal flash memory of a MCU as storage device.

The following table shows the serial NOR flash devices that were tested by SEGGER or are known to be compatible with a tested device.

Device name	Storage capacity	Device type	Supported extra features
Cypress/Spansion			
S25FL032P	32 Mibit	SPI	extended SPI
S25FL064L	64 Mibit	SPI	extended SPI
S25FL064P	64 Mibit	SPI	extended SPI
S25FL127S	128 Mibit	SPI	extended SPI
S25FL128L	128 Mibit	SPI	extended SPI
S25FL128S	128 Mibit	SPI	extended SPI

Device name	Storage capacity	Device type	Supported extra features
S25FL129P	128 Mibit	SPI	extended SPI
S25FL132K	32 Mibit	SPI	extended SPI
S25FL164K	64 Mibit	SPI	extended SPI
S25FL256L	256 Mibit	SPI	extended SPI
S25FL256S	256 Mibit	SPI	extended SPI
S25FL512S	512 Mibit	SPI	extended SPI
S25FS128S	128 Mibit	SPI	extended SPI
S25FS256S	256 Mibit	SPI	extended SPI
S25FS512S	512 Mibit	SPI	extended SPI
S26KL512S	512 Mibit	HyperBus	write buffer
S29GL064N	64 Mibit	CFI	write buffer
S70FL01GS	1 Gibit	SPI	extended SPI
S70FL256P	256 Mibit	CFI	extended SPI
Dialog Semiconductor/Adesto/Atmel			
AT25SF128A	128 Mibit	SPI	extended SPI
AT25SL321	32 Mibit	SPI	extended SPI
AT25XE041D	4 Mibit	SPI	extended SPI
AT25XE081D	8 Mibit	SPI	extended SPI
AT25XE321D	32 Mibit	SPI	extended SPI
Eon			
EN25QH128A	128 Mibit	SPI	extended SPI
EN25QX64A	64 Mibit	SPI	extended SPI
GigaDevice			
GD25LQ128D	128 Mibit	SPI	extended SPI
GD25LQ128E	128 Mibit	SPI	extended SPI
GD25LQ16C	16 Mibit	SPI	extended SPI
GD25Q127C	128 Mibit	SPI	extended SPI
GD25Q16B	16 Mibit	SPI	extended SPI
GD25Q256D	256 Mibit	SPI	extended SPI
GD25Q32C	32 Mibit	SPI	extended SPI
GD25Q64C	64 Mibit	SPI	extended SPI
GD25Q64E	64 Mibit	SPI	extended SPI
ISSI			
IS25LP01G	1 Gibit	SPI	extended SPI
IS25LP032D	32 Mibit	SPI	extended SPI
IS25LP064A	64 Mibit	SPI	extended SPI
IS25LP128	128 Mibit	SPI	extended SPI
IS25LP128F	128 Mibit	SPI	extended SPI
IS25LP256D	256 Mibit	SPI	extended SPI
IS25LP256E	256 Mibit	SPI	extended SPI
IS25LP512M	512 Mibit	SPI	extended SPI
IS25LQ016B	16 Mibit	SPI	extended SPI
IS25LQ032B	32 Mibit	SPI	extended SPI

Device name	Storage capacity	Device type	Supported extra features
IS25LQ080	8 Mibit	SPI	extended SPI
IS25LQ080B	8 Mibit	SPI	extended SPI
IS25WP01G	1 Gibit	SPI	extended SPI
IS25WP064A	64 Mibit	SPI	extended SPI
IS25WP256D	256 Mibit	SPI	extended SPI
Macronix			
MX25L12835F	128 Mibit	SPI	extended SPI
MX25L25635F	256 Mibit	SPI	extended SPI
MX25L25645G	256 Mibit	SPI	extended SPI
MX25L3233F	32 Mibit	SPI	extended SPI
MX25L3235E	32 Mibit	SPI	extended SPI
MX25L51245G	512 Mibit	SPI	extended SPI
MX25L6433F	64 Mibit	SPI	extended SPI
MX25L8035E	8 Mibit	SPI	extended SPI
MX25LM51245G	512 Mibit	SPI	OPI STR, OPI DTR
MX25R3235F	32 Mibit	SPI	extended SPI
MX25R6435F	64 Mibit	SPI	extended SPI
MX25U256	256 Mibit	SPI	extended SPI
MX25UM51245G	512 Mibit	SPI	OPI STR, OPI DTR
MX25V1635F	16 Mibit	SPI	extended SPI
MX66L1G45G	1 Gibit	SPI	extended SPI
MX66L2G45G	2 Gibit	SPI	extended SPI
MX66L51235F	512 Mibit	SPI	extended SPI
MX66U2G45G	2 Gibit	SPI	extended SPI
Microchip			
SST25VF016B	16 Mibit	SPI	
SST26VF016B	16 Mibit	SPI	extended SPI
SST26VF032B	32 Mibit	SPI	extended SPI
SST26VF032BA	32 Mibit	SPI	extended SPI
SST26VF064B	64 Mibit	SPI	extended SPI
Micron			
M25P128	128 Mibit	SPI	
M25P16	16 Mibit	SPI	
M25P32	32 Mibit	SPI	
M25P40	4 Mibit	SPI	
M25P64	64 Mibit	SPI	
M25P80	8 Mibit	SPI	
M25PX16	16 Mibit	SPI	
M28F256	256 Kibit	CFI	
M28W160	16 Mibit	CFI	
M28W320	32 Mibit	CFI	
M28W640	64 Mibit	CFI	
M29F080	8 Mibit	CFI	

Device name	Storage capacity	Device type	Supported extra features
M29W128GL	128 Mibit	CFI	
M29W160	16 Mibit	CFI	
M29W320	32 Mibit	CFI	
M29W640	64 Mibit	CFI	
M58LW064	64 Mibit	CFI	
MT25QL01GBB	1 Gibit	SPI	extended SPI
MT25QL02GC	2 Gibit	SPI	extended SPI
MT25QL128ABA	128 Mibit	SPI	extended SPI
MT25QL256ABA	256 Mibit	SPI	extended SPI
MT25QL512ABB	512 Mibit	SPI	extended SPI
MT25QU01GAB	1 Gibit	SPI	extended SPI
MT25QU02GAB	2 Gibit	SPI	extended SPI
MT25QU128ABA	128 Mibit	SPI	extended SPI
MT25TL01GHBB	1 Gibit	SPI	extended SPI
MT28F128	128 Mibit	CFI	
MT28F320	32 Mibit	CFI	
MT28F640	64 Mibit	CFI	
N25Q00AA	1 Gibit	SPI	extended SPI
N25Q032A	32 Mibit	SPI	extended SPI
N25Q064	64 Mibit	SPI	extended SPI
N25Q064A	64 Mibit	SPI	extended SPI
N25Q128A	128 Mibit	SPI	extended SPI
N25Q256	256 Mibit	SPI	extended SPI
N25Q256A	256 Mibit	SPI	extended SPI
N25Q512A	512 Mibit	SPI	extended SPI
TE28F128P30B85	128 Mibit	CFI	
TE28F128P33B85	128 Mibit	CFI	
TE28F256P30B95	256 Mibit	CFI	
TE28F256P33B95	256 Mibit	CFI	
TE28F640P30B85	64 Mibit	CFI	
TE28F640P33B85	64 Mibit	CFI	
STMicroelectronics			
M95P32	32 Mibit	SPI	extended SPI
Winbond			
W25Q128FW	128 Mibit	SPI	extended SPI
W25Q128JV	128 Mibit	SPI	extended SPI
W25Q16DV	16 Mibit	SPI	extended SPI
W25Q16JV	16 Mibit	SPI	extended SPI
W25Q256JV	256 Mibit	SPI	extended SPI
W25Q256JW	256 Mibit	SPI	extended SPI
W25Q32JV	32 Mibit	SPI	extended SPI
W25Q512JV	512 Mibit	SPI	extended SPI, DTR
W25Q64FV	64 Mibit	SPI	extended SPI

Device name	Storage capacity	Device type	Supported extra features
W25Q64FW	64 Mibit	SPI	extended SPI
W25Q64JV	64 Mibit	SPI	extended SPI
W25Q80DV	8 Mibit	SPI	extended SPI
W25Q80EW	8 Mibit	SPI	extended SPI

Support for devices not available in this list

Most other NOR flash devices are compatible with one of the supported devices. Thus the driver can be used with these devices or may only need a little modification, which can easily be done. Get in touch with us if you have questions about support for devices not in this list.

6.4.1.8.1 Using the same NOR flash device for code and data

Most NOR flash device cannot be read out during a program or erase operation. This means that the CPU cannot execute code from the NOR flash device while the NOR flash device is busy performing a program or erase operation. A program crash is almost certain if the CPU tries to execute code in this case.

There are multiple options to solve this problem:

1. Multiple NOR flash devices can be used with code and data being stored on different devices.
2. A NOR flash device that supports multiple flash banks can be used. Typically, this type of NOR flash device allows the code execution from one bank while performing an erase or program operation on a different one.
3. The hardware routines that program, erase or identify the NOR flash device are located in RAM and the interrupts are disabled.

6.4.1.9 Interfacing with a NOR flash device

The most common setup is a CFI compliant NOR flash device with a 16-bit interface. The picture below shows how this can be realized.

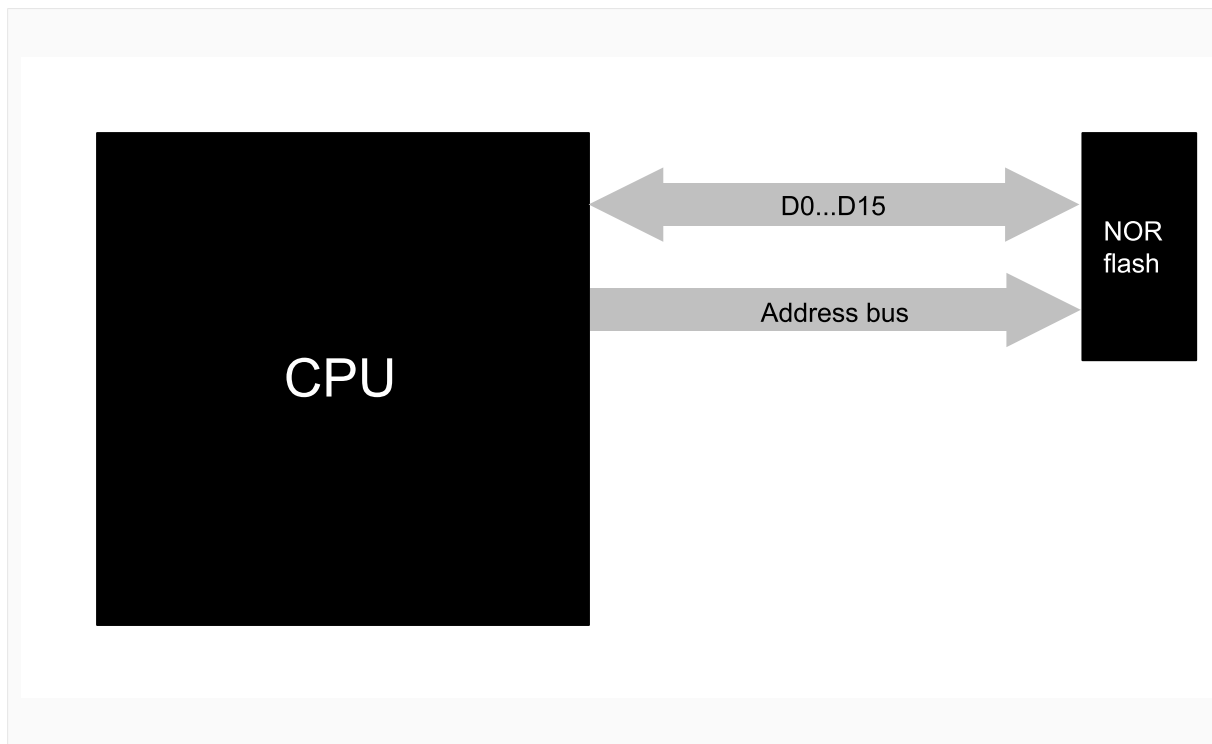

NOR physical interface

In addition to this, emFile supports the use of two CFI compliant NOR flash devices with a 16-bit interface which are connected to the same address bus as illustrated in the picture below.

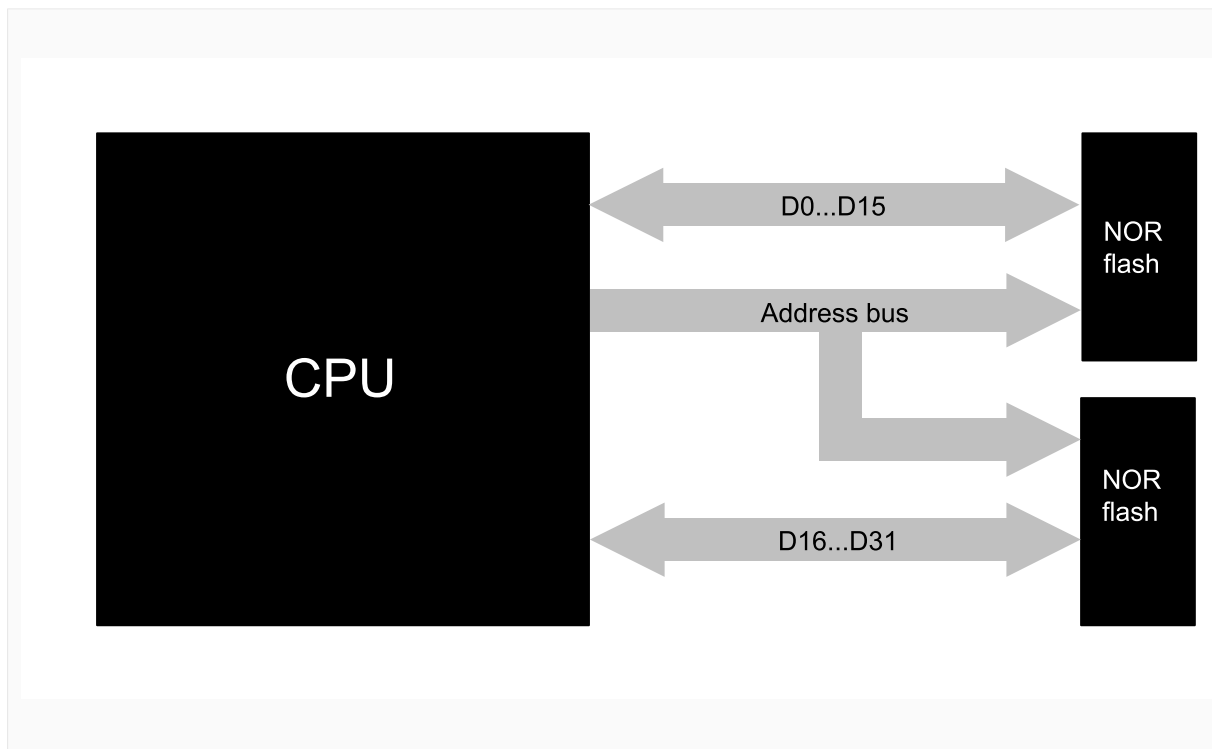

Dual NOR physical interface

6.4.1.10 Common flash interface (CFI)

The NOR flash drivers can be used with any CFI-compliant 16-bit device. CFI is an open specification which may be implemented freely by flash memory vendors in their devices. It was developed jointly by Intel, AMD, Sharp, and Fujitsu. The idea behind CFI was the interchangeability of current and future flash memory devices offered by different vendors. If you use only CFI compliant flash memory device, you are able to use one driver for different flash products by reading identifying information out of the flash device itself. The identifying information for the device, such as memory size, byte/word configuration, block configuration, necessary voltages, and timing information, is stored directly on the device. For more technical details about CFI (Common Flash Interface) and SFDP (Serial Flash Discoverable Parameters), check the documents and specifications that are available free of charge at <https://www.jedec.org>

6.4.2 Sector Map NOR driver

This section describes the NOR driver that was optimized for increased write performance. The Sector Map NOR driver works by mapping single logical sectors to locations on the NOR flash device.

6.4.2.1 Theory of operation

Differentiating between logical sectors or blocks and physical sectors is essential to understand this section. A logical sector/block is the smallest readable and writable unit of any file system and its usual size is 512 bytes. A physical sector is an array of bytes on the NOR flash device that are erased together (typically between 2 Kbytes - 128 Kbytes). The Sector Map NOR driver is an abstraction layer between these two types of sectors.

Every time a logical sector is being updated, it is marked as invalid and the new content of this sector is written into another area of the flash. The physical address and the order of physical sectors can change with every write access. Hence, a direct relation between the sector number and its physical location cannot exist. The flash driver manages the logical sector numbers by writing it into special headers. To the upper layer, it does not matter where the logical sector is stored or how much flash memory is used as a buffer. All logical sectors (starting with sector 0) always exist and are always available for user access.

6.4.2.2 Configuring the driver

This section describes how to configure the file system to make use of the Sector Map NOR driver.

6.4.2.2.1 Compile time configuration

The Sector Map NOR driver can optionally be configured at compile time. Typically, this step can be omitted because reasonable default values are provided that work with most of the applications. The compile time configuration is realized via preprocessor defines that have to be added to the `FS_Conf.h` file which is the main configuration file of emFile. For detailed information about the configuration of emFile and of the configuration define types, refer to *Configuration of emFile* on page 1218. The following table lists the configuration defines supported by the Sector Map NOR driver.

Define	Default value	Type	Description
<code>FS_NOR_CAN_REWRITE</code>	1	B	Indicates if modifying the same byte on the NOR flash device more than one time is permitted.
<code>FS_NOR_ENABLE_STATS</code>	0 or 1	B	Enables or disables the support for statistical counters.
<code>FS_NOR_LINE_SIZE</code>	1	N	Number of bytes in a write unit.
<code>FS_NOR_MAX_ERASE_CNT</code>	500000	N	Configures the maximum value of a valid erase count.
<code>FS_NOR_MAX_ERASE_CNT_DIFF</code>	5000	N	Configures the default maximum difference between erase counts.
<code>FS_NOR_NUM_FREE_SECTOR-CACHE</code>	100	N	Configures the default capacity of the list that stores the indexes of free sectors.
<code>FS_NOR_NUM_UNITS</code>	4	N	Maximum number of driver instances.
<code>FS_NOR_OPTIMIZE_DIRTY-CHECK</code>	1	B	Enables or disables the optimization for the blank checking of logical sectors.

Define	Default value	Type	Description
FS_NOR_OPTIMIZE_HEADER_WRITE	0	B	Enables or disables the optimization for the writing of management data.
FS_NOR_READ_BUFFER_FILL_PATTERN	0xFF	N	Configures a bit pattern to be used for filling the contents of invalid logical sectors.
FS_NOR_SKIP_BLANK_SECTORS	1	B	Enables or disables the support for erasing blank physical sectors at low-level format.
FS_NOR_SUPPORT_CLEAN	1	B	Enables or disables the support for executing the garbage collection in the application.
FS_NOR_SUPPORT_VARIABLE_LINE_SIZE	0	B	Enables or disables the support for configuring at runtime the minimum number of bytes to be written at once.
FS_NOR_VERIFY_WRITE	0	B	Reads back and compares the sector data to check if the write operation was successful.
FS_NOR_VERIFY_ERASE	0	B	Reads back and compares the sector data to check if the erase operation was successful.

6.4.2.2.1.1 FS_NOR_CAN_REWRITE

For the majority of NOR flash device the same byte can be modified more than once without a erase operation in between while preserving the bits set to 0. That is a byte can be written up to eight times with each write operation setting a different bit in that byte to 0. The Sector Map NOR driver makes use of this feature to make efficient use of the storage space and to improve the performance. `FS_NOR_CAN_REWRITE` has to be set to 0 for NOR flash devices that permit only one write operation to a byte or a range of bytes between two erase operations of that storage block.

6.4.2.2.1.2 FS_NOR_ENABLE_STATS

This define can be used to enable the support for statistical counters. The statistical counters provide information about the number of operations performed internally by the Sector Map NOR driver that can be useful for debugging. The statistical counters can be queried via `FS_NOR_GetStatCounters()`. By default `FS_NOR_ENABLE_STATS` is set to 1 if `FS_DEBUG_LEVEL` is set to a value greater than or equal to `FS_DEBUG_LEVEL_CHECK_ALL`.

6.4.2.2.1.3 FS_NOR_LINE_SIZE

`FS_NOR_LINE_SIZE` specifies the minimum number of bytes the Sector Map NOR driver writes at once. The amount of data written is always a multiple of this value. In addition, `FS_NOR_LINE_SIZE` specifies the alignment of the written data. That is the offset at which the Sector Map NOR driver writes the data is always a multiple of this value. `FS_NOR_LINE_SIZE` has to be a power of two value.

6.4.2.2.1.4 FS_NOR_MAX_ERASE_CNT

The Sector Map NOR driver uses the value of `FS_NOR_MAX_ERASE_CNT` to check the validity of an erase count stored in the header of a physical sector. If the value of the erase count is larger than `FS_NOR_MAX_ERASE_CNT` then the erase count is considered invalid and is set to the maximum value of all valid erase counts.

6.4.2.2.1.5 FS_NOR_MAX_ERASE_CNT_DIFF

The value of this define is used by the Sector Map NOR driver during the wear leveling procedure to decide which physical sector has to be used for storage. `FS_NOR_SetMaxEraseCntDiff()` can be used to modify this value at runtime. Refer to *Wear Leveling* on page 731 for more information about how this value is used.

6.4.2.2.1.6 FS_NOR_NUM_FREE_SECTORCACHE

`FS_NOR_NUM_FREE_SECTORCACHE` can be used to specify the maximum number of physical sector indexes that an instance of the Sector Map NOR driver can remember as being ready to store data. Each entry of this list occupies 4 bytes. Increasing the capacity of the list can help increase the performance of the write operation at the cost of increased RAM usage.

6.4.2.2.1.7 FS_NOR_NUM_UNITS

This define specifies the maximum number of driver instances of the Sector Map NOR driver the application is allowed create. Four bytes of static RAM are reserved for each instance. If the maximum number of driver instances is smaller than the default then `FS_NOR_NUM_UNITS` can be set to the to that value in order to reduce the RAM usage.

6.4.2.2.1.8 FS_NOR_OPTIMIZE_DIRTY_CHECK

This define can be used to enable a speed optimization related to the check performed by the the Sector Map NOR driver to determine if a logical sector is blank or not. With `FS_NOR_OPTIMIZE_DIRTY_CHECK` set to 1 the Sector Map NOR driver remembers which physical sectors were already checked so that the blank checking operation can be skipped. Activating this feature can help improve the write performance at the cost of increased RAM usage. The Sector Map NOR driver requires 1 bit of RAM for each physical sector used as storage.

6.4.2.2.1.9 FS_NOR_OPTIMIZE_HEADER_WRITE

`FS_NOR_OPTIMIZE_HEADER_WRITE` can be used to specify how the management data is written to storage. The management data is stored at the beginning of each physical and logical sector in an area called header. By default, the size of the physical sector header is 16 bytes and of the logical sector header is 8 bytes. The size of these headers is larger for NOR flash devices that specify a minimum number of bytes that have to be written at once and that are not able to perform incremental write operations. The default behavior of the Sector Map NOR driver, that is when `FS_NOR_OPTIMIZE_HEADER_WRITE` is set to 0, is to write the entire header every time some of the information stored in it changes. With `FS_NOR_OPTIMIZE_HEADER_WRITE` set to 1 the Sector Map NOR driver tracks the changes made to a header and writes only the information that actually changed. Reducing the amount of data written to storage can help increase the write performance.

The internal flash memory of some MCUs do not allow a second write operation to the same byte with identical data without an erase operation in between. If this type of flash memory is used as storage then it is mandatory to set `FS_NOR_OPTIMIZE_HEADER_WRITE` to 1.

6.4.2.2.1.10 FS_NOR_READ_BUFFER_FILL_PATTERN

The value of `FS_NOR_READ_BUFFER_FILL_PATTERN` is used by the Sector Map NOR driver to fill the contents of invalid logical sectors that is logical sectors that were not written yet. The contents of all logical sectors is invalid after a low-level format operation. In addition, the contents of a logical sector can be invalidated via `FS_STORAGE_FreeSectors()`.

6.4.2.2.1.11 FS_NOR_SKIP_BLANK_SECTORS

`FS_NOR_SKIP_BLANK_SECTORS` can be used to enable the support for the optimization that omits the erase of physical sectors that are already blank. This feature has to be explicitly enabled a runtime by calling `FS_NOR_BM_SetBlankSectorSkip()`.

6.4.2.2.1.12 FS_NOR_SUPPORT_CLEAN

This define specifies if the application is allowed to perform a garbage collection operation. If `FS_NOR_SUPPORT_CLEAN` is set to 1 then the application can perform a garbage collec-

tion operation via `FS_STORAGE_Clean()` and `FS_STORAGE_CleanOne()`. For more information about the garbage collection refer to *Garbage collection* on page 730. The automatic garbage collection operation performed by the Sector Map NOR driver is not disabled when `FS_NOR_SUPPORT_CLEAN` is set to 0. If the application does not call either `FS_STORAGE_Clean()` or `FS_STORAGE_CleanOne()` then `FS_NOR_SUPPORT_CLEAN` can be safely set to 0 in order to save ROM space.

6.4.2.2.1.13 FS_NOR_SUPPORT_VARIABLE_LINE_SIZE

`FS_NOR_SUPPORT_VARIABLE_LINE_SIZE` can be used to enable the runtime configuration of the minimum number of bytes to be written by the Sector Map NOR driver at once. With `FS_NOR_SUPPORT_VARIABLE_LINE_SIZE` set to 1 the minimum number of bytes to be written at once can be configured via `FS_NOR_SetDeviceLineSize()` between 1 and `FS_NOR_LINE_SIZE`. In addition, the ability of the NOR flash device to perform incremental write operations can be configured via `FS_NOR_SetDeviceRewriteSupport()`.

`FS_NOR_SUPPORT_VARIABLE_LINE_SIZE` is set to 1 when building the NOR Image Creator utility in order to give it the ability to create images for NOR flash devices with different characteristics. Typically, there is no need to modify the default value of `FS_NOR_SUPPORT_VARIABLE_LINE_SIZE` when building a target application.

6.4.2.2.1.14 FS_NOR_VERIFY_WRITE

This define can be used to activate the write verification of the Sector Map NOR driver. The write verification is performed after each write operation by reading back the modified data from storage and by comparing it with the data requested to be written. An error is reported if a difference is detected. This feature has to be enabled at runtime by calling `FS_NOR_SetWriteVerification()`.

Note

Activating the write verification can negatively affect the write performance.

6.4.2.2.1.15 FS_NOR_VERIFY_ERASE

This define can be used to activate the erase verification of the Sector Map NOR driver. The erase verification is performed after each erase operation by reading back the entire data of the erase physical sector from storage and by comparing it with `0xFF`. An error is reported if a difference is detected. This feature has to be enabled at runtime by calling `FS_NOR_SetWriteVerification()`.

Note

Activating the erase verification can negatively affect the write performance.

6.4.2.2.2 Runtime configuration

The driver must be added to the file system by calling `FS_AddDevice()` with the driver identifier set to the address of `FS_NOR_Driver`. This function call together with other function calls that configure the driver operation have to be added to `FS_X_AddDevices()` as demonstrated in the following example. This example shows how to configure the file system to access a NOR flash device connected via SPI.

```
#include "FS.h"

#define ALLOC_SIZE          0x4000          // Size defined in bytes
#define BYTES_PER_SECTOR  2048

static U32 _aMemBlock[ALLOC_SIZE / 4]; // Memory pool used for
                                        // semi-dynamic allocation.

/*****
*
```

```

*     FS_X_AddDevices
*
*   Function description
*     This function is called by the FS during FS_Init().
*/
void FS_X_AddDevices(void) {
    //
    // Give the file system memory to work with.
    //
    FS_AssignMemory(&aMemBlock[0], sizeof(_aMemBlock));
    //
    // Add and configure the NOR flash driver. The first 65536 bytes of the
    // serial NOR flash device are not used by the file system as data storage
    // and can be used by the application for other purposes. The file system
    // uses a total of 1 Mbyte from the serial NOR flash device as storage.
    //
    FS_AddDevice(&FS_NOR_Driver);
    FS_NOR_SetPhyType(0, &FS_NOR_PHY_ST_M25);
    FS_NOR_Configure(0, 0x00000000, 0x00010000, 0x00100000);
    FS_NOR_SetSectorSize(0, BYTES_PER_SECTOR);
    //
    // Set a larger logical sector size as the default
    // in order to reduce the RAM usage of the NOR driver.
    //
    FS_SetMaxSectorSize(BYTES_PER_SECTOR);
}

```

The API functions listed in the next table can be used by the application to configure the behavior of the Sector Map NOR driver. The application can call them only at the file system initialization in `FS_X_AddDevices()`.

Function	Description
<code>FS_NOR_Configure()</code>	Configures an instance of the sector map NOR driver.
<code>FS_NOR_ConfigureReserve()</code>	Configures the number of logical sectors to be reserved.
<code>FS_NOR_SetBlankSectorSkip()</code>	Configures if the physical sectors which are already blank should be erased during the low-level format operation.
<code>FS_NOR_SetDeviceLineSize()</code>	Configures the minimum number of bytes that can be written to NOR flash.
<code>FS_NOR_SetDeviceRewriteSupport()</code>	Specifies if the NOR flash device can rewrite the same data if 0s are preserved.
<code>FS_NOR_SetDirtyCheckOptimization()</code>	Enables or disables the blank checking of a logical sector before write.
<code>FS_NOR_SetEraseVerification()</code>	Enables or disables the checking of the sector erase operation.
<code>FS_NOR_SetPhyType()</code>	Configures the type of NOR physical layer.
<code>FS_NOR_SetSectorSize()</code>	Configures the number of bytes in a logical sector.
<code>FS_NOR_SetWriteVerification()</code>	Enables or disables the checking of the page write operation.

6.4.2.2.1 FS_NOR_Configure()

Description

Configures an instance of the sector map NOR driver

Prototype

```
void FS_NOR_Configure(U8 Unit,
                    U32 BaseAddr,
                    U32 StartAddr,
                    U32 NumBytes);
```

Parameters

Parameter	Description
Unit	Index of the sector map NOR driver (0-based).
BaseAddr	Address of the first byte in NOR flash.
StartAddr	Address of the first byte the NOR driver is permitted to use as storage.
NumBytes	Number of bytes starting from StartAddr available to be used by the NOR driver as storage.

Additional information

This function is mandatory and it has to be called once in FS_X_AddDevices() for each instance of the sector map NOR driver created by the application. Different instances of the NOR driver are identified by the Unit parameter.

BaseAddr is used only for NOR flash devices that are memory mapped. For serial NOR flash devices that are not memory mapped BaseAddr has to be set to 0.

StartAddr has to be greater than or equal to BaseAddr and smaller than the total number of bytes in the NOR flash device. The sector map NOR driver rounds up StartAddr to the start address of the next physical sector in the NOR flash device.

NumBytes is rounded up to a physical sector boundary if the memory range defined by StartAddr and NumBytes is smaller than the capacity of the NOR flash device. If the memory range defined by StartAddr and NumBytes is larger than the capacity of the NOR flash device than NumBytes is rounded down so that the memory range fits into the NOR flash device.

The sector map NOR driver can work with physical sectors of different size. It is required that at least two physical sectors of each sector size are available.

Example

The following sample demonstrates how to configure the file system to work with a single CFI compliant NOR flash device connected via a 16-bit data bus.

```
#include "FS.h"

#define ALLOC_SIZE 0x2000 // Size defined in bytes

static U32 _aMemBlock[ALLOC_SIZE / 4]; // Memory pool used for
// semi-dynamic allocation.

/*****
 *
 * FS_X_AddDevices
 *
 * Function description
 * This function is called by the FS during FS_Init().
 */
void FS_X_AddDevices(void) {
    //
    // Give the file system memory to work with.
```

```

//
FS_AssignMemory(&_aMemBlock[0], sizeof(_aMemBlock));
//
// Add the NOR driver.
//
FS_AddDevice(&FS_NOR_Driver);
//
// Set the physical layer type for single CFI compliant
// NOR flash device with 16-bit data bus interface.
//
FS_NOR_SetPhyType(0, &FS_NOR_PHY_CFI_1x16);
//
// Configure the range of NOR flash device to be used as storage (2 Mbytes)
//
FS_NOR_Configure(0, 0x1000000, 0x1000000, 0x00200000);
}

```

The next sample demonstrates how to configure the file system to work with two CFI compliant NOR flash devices with each device being connected via a separate 16-bit data bus.

```

#include "FS.h"

#define ALLOC_SIZE 0x4000 // Size defined in bytes

static U32 _aMemBlock[ALLOC_SIZE / 4]; // Memory pool used for
// semi-dynamic allocation.

/*****
*
* FS_X_AddDevices
*
* Function description
* This function is called by the FS during FS_Init().
*/
void FS_X_AddDevices(void) {
//
// Give the file system memory to work with.
//
FS_AssignMemory(&_aMemBlock[0], sizeof(_aMemBlock));
//
// Add the NOR driver.
//
FS_AddDevice(&FS_NOR_Driver);
//
// Set the physical layer type for two CFI compliant
// NOR flash devices with 16-bit data bus interface.
//
FS_NOR_SetPhyType(0, &FS_NOR_PHY_CFI_2x16);
//
// Configure the range of NOR flash device to be used as storage (2 Mbytes each)
//
FS_NOR_Configure(0, 0x1000000, 0x1000000, 0x00400000);
}

```

The file system is able to handle two or more NOR flash devices that are not connected in parallel. The next sample shows how this can be realized.

```

#include "FS.h"

#define ALLOC_SIZE 0x4000 // Size defined in bytes

static U32 _aMemBlock[ALLOC_SIZE / 4]; // Memory pool used for
// semi-dynamic allocation.

/*****
*
* FS_X_AddDevices
*
* Function description
* This function is called by the FS during FS_Init().
*/
void FS_X_AddDevices(void) {

```



```
//  
// Give the file system memory to work with.  
//  
FS_AssignMemory(&_aMemBlock[0], sizeof(_aMemBlock));  
//  
// Add and configure the first NOR driver. The storage can be accessed  
// using the volume name "nor:0:". The physical layer is set to single  
// CFI compliant NOR flash device with 16-bit interface. The NOR flash  
// device is mapped at address 0x10000000 in the system memory and  
// 2 Mbytes of it are used by the file system as storage.  
//  
FS_AddDevice(&FS_NOR_Driver);  
FS_NOR_SetPhyType(0, &FS_NOR_PHY_CFI_1x16);  
FS_NOR_Configure(0, 0x1000000, 0x1000000, 0x00200000);  
//  
// Add and configure the second NOR driver. The storage can be accessed  
// using the volume name "nor:1:". The physical layer is set to single  
// CFI compliant NOR flash device with 16-bit interface. The NOR flash  
// device is mapped at address 0x40000000 in the system memory and  
// 4 Mbytes of it are used by the file system as storage.  
//  
FS_AddDevice(&FS_NOR_Driver);  
FS_NOR_SetPhyType(1, &FS_NOR_PHY_CFI_1x16);  
FS_NOR_Configure(1, 0x4000000, 0x4000000, 0x00400000);  
}
```

6.4.2.2.2 FS_NOR_ConfigureReserve()

Description

Configures the number of logical sectors to be reserved.

Prototype

```
void FS_NOR_ConfigureReserve(U8 Unit,  
                             U8 pctToReserve);
```

Parameters

Parameter	Description
<code>Unit</code>	Index of the sector map NOR driver (0-based).
<code>pctToReserve</code>	Percent of the total number of logical sectors to reserve.

Additional information

This function is optional. By default, the sector map NOR driver reserves about 10% of the total number of logical sector for future improvements and extensions. `FS_NOR_ConfigureReserve()` can be used in an application to modify this value. If set to 0 the sector map NOR driver uses all the available logical sectors to store file system data.

The application has to reformat the NOR flash device in order for the modified value to take effect.

6.4.2.2.2.3 FS_NOR_SetBlankSectorSkip()

Description

Configures if the physical sectors which are already blank should be erased during the low-level format operation.

Prototype

```
void FS_NOR_SetBlankSectorSkip(U8 Unit,
                               U8 OnOff);
```

Parameters

Parameter	Description
<code>Unit</code>	Index of the sector map NOR driver (0-based).
<code>OnOff</code>	Specifies if the feature has to be enabled or disabled <ul style="list-style-type: none"> • =0 All the physical sectors are erased. • ≠0 Physical sectors are not erased if they are blank (default).

Additional information

This function is optional. The blank checking feature is disabled by default and has to be explicitly enabled at compile time by setting `FS_NOR_SKIP_BLANK_SECTORS` to 1. The feature can then be enabled or disabled at runtime using `FS_NOR_SetBlankSectorSkip()`.

Activating this feature can improve the speed of the low-level format operation when most of the physical sectors of the NOR flash device are already blank which is typically the case with NOR flash devices that ship from factory.

6.4.2.2.2.4 FS_NOR_SetDeviceLineSize()

Description

Configures the minimum number of bytes that can be written to NOR flash.

Prototype

```
void FS_NOR_SetDeviceLineSize(U8 Unit,  
                               U8 ldBytesPerLine);
```

Parameters

Parameter	Description
<code>Unit</code>	Index of the sector map NOR driver (0-based).
<code>ldBytesPerLine</code>	Line size in bytes as power of 2 exponent.

Additional information

This function is optional. Typically, the NOR flash have lines smaller than 4 bytes which is the fixed default value configured at compile time. The `FS_NOR_SUPPORT_VARIABLE_LINE_SIZE` configuration define has to be set to a value different than 0 in order to enable this function.

6.4.2.2.2.5 FS_NOR_SetDeviceRewriteSupport()

Description

Specifies if the NOR flash device can rewrite the same data if 0s are preserved.

Prototype

```
void FS_NOR_SetDeviceRewriteSupport(U8 Unit,
                                     U8 OnOff);
```

Parameters

Parameter	Description
Unit	Index of the sector map NOR driver (0-based).
OnOff	Specifies if the feature has to be enabled or disabled <ul style="list-style-type: none"> • =0 Rewrite operations are not performed. • ≠0 Rewrite operation are performed (default).

Additional information

This function is optional. Typically, the NOR flash devices are able to rewrite the same data and by default this feature is disabled at compile time. The `FS_NOR_SUPPORT_VARIABLE_LINE_SIZE` configuration define has to be set to a value different than 0 in order to enable this function, otherwise the function does nothing.

6.4.2.2.2.6 FS_NOR_SetDirtyCheckOptimization()

Description

Enables or disables the blank checking of a logical sector before write.

Prototype

```
void FS_NOR_SetDirtyCheckOptimization(U8 Unit,
                                       U8 OnOff);
```

Parameters

Parameter	Description
<code>Unit</code>	Index of the sector map NOR driver (0-based).
<code>OnOff</code>	Specifies if the feature has to be enabled or disabled <ul style="list-style-type: none"> • =0 Dirty check is disabled (default). • ≠0 Dirty check is enabled.

Additional information

This function is optional. Per default, the NOR driver checks if the data of the logical sector is blank (all bytes `0xFF`) before it writes the data. This is necessary in order to make sure that the NOR driver does not write to partially written logical sectors. Writing to a partially written logical sector can cause a data loss since the write operation can change the value of a bit only from 1 to 0. A partially written logical sector occurs when the write operation is interrupted by an unexpected reset. In this case the status of the logical sector indicates that the logical sector is blank which is not correct. Therefore the logical sector cannot be used for storage and it is marked by the NOR driver as invalid.

Typically, the blank checking runs fast but on some targets it may reduce the write performance. In this cases, this option can be used to skip the blank checking which helps improve the performance. When the optimization is enabled, the blank checking is not longer performed on the logical sectors located on physical sectors that have been erased at least once since the last mount operation. The NOR driver can skip the blank checking for these physical sectors since it knows that they do not contain any partially written logical sectors. The application can remove any partially written logical sectors by performing a clean operation of the entire storage via the `FS_STORAGE_Clean()` or `FS_STORAGE_CleanOne()` API functions. The NOR driver requires one bit of RAM storage for each physical sector used as storage.

The `FS_NOR_OPTIMIZE_DIRTY_CHECK` configuration define has to be set to a value different than 0 in order to enable this function, otherwise the function does nothing.

6.4.2.2.7 FS_NOR_SetEraseVerification()

Description

Enables or disables the checking of the sector erase operation.

Prototype

```
void FS_NOR_SetEraseVerification(U8 Unit,
                                U8 OnOff);
```

Parameters

Parameter	Description
<code>Unit</code>	Index of the sector map NOR driver (0-based).
<code>OnOff</code>	Specifies if the feature has to be enabled or disabled <ul style="list-style-type: none"> • =0 The erase operation is not checked. • ≠0 The erase operation is checked.

Additional information

This function is optional. The result of a sector erase operation is normally checked by evaluating the error bits maintained by the NOR flash device in a internal status register. `FS_NOR_SetEraseVerification()` can be used to enable additional verification of the sector erase operation that is realized by reading back the contents of the entire erased physical sector and by checking that all the bytes in it are set to `0xFF`. Enabling this feature can negatively impact the write performance of sector map NOR driver.

The sector erase verification feature is active only when the sector map NOR driver is compiled with the `FS_NOR_VERIFY_ERASE` configuration define is set to 1 (default is 0) or when the `FS_DEBUG_LEVEL` configuration define is set to a value greater than or equal to `FS_DEBUG_LEVEL_CHECK_ALL`.

6.4.2.2.2.8 FS_NOR_SetPhyType()

Description

Configures the type of NOR physical layer.

Prototype

```
void FS_NOR_SetPhyType(      U8          Unit,
                           const FS_NOR_PHY_TYPE * pPhyType);
```

Parameters

Parameter	Description
<code>Unit</code>	Index of the sector map NOR driver (0-based).
<code>pPhyType</code>	<code>in</code> NOR physical layer.

Additional information

This function is mandatory and it has to be called once in `FS_X_AddDevices()` for each instance of the sector map NOR driver created by the application. Different instances of the sector map NOR driver are identified by the `Unit` parameter.

Permitted values for the `pPhyType` parameter are:

Identifier	Description
<code>FS_NOR_PHY_CFI_1x16</code>	One CFI compliant NOR flash device with 16-bit interface.
<code>FS_NOR_PHY_CFI_2x16</code>	Two CFI compliant NOR flash device with 16-bit interfaces.
<code>FS_NOR_PHY_DSPI</code>	This a pseudo physical layer that uses the physical layers <code>FS_NOR_PHY_ST_M25</code> and <code>FS_NOR_PHY_SFDP</code>
<code>FS_NOR_PHY_SFDP</code>	Serial NOR flash devices that support Serial Flash Discoverable Parameters (SFDP)
<code>FS_NOR_PHY_SPIFI</code>	Memory mapped serial quad NOR flash devices.
<code>FS_NOR_PHY_ST_M25</code>	Serial NOR flash devices compatible to ST ST25Pxx.

6.4.2.2.2.9 FS_NOR_SetSectorSize()

Description

Configures the number of bytes in a logical sector.

Prototype

```
void FS_NOR_SetSectorSize(U8 Unit,  
                          U16 SectorSize);
```

Parameters

Parameter	Description
<code>Unit</code>	Index of the sector map NOR driver (0-based).
<code>SectorSize</code>	Number of bytes in a logical sector.

Additional information

This function is optional. It can be used to modify the size of the logical sector used by the sector map NOR driver. By default the sector map NOR driver uses the logical sector size configured a file system level that is set to 512 bytes at the file system initialization and can be later changed via `FS_SetMaxSectorSize()`. The NOR flash device has to be reformatted in order for the new logical sector size to take effect.

`SectorSize` has to be a power of 2 value.

6.4.2.2.2.10 FS_NOR_SetWriteVerification()

Description

Enables or disables the checking of the page write operation.

Prototype

```
void FS_NOR_SetWriteVerification(U8 Unit,
                                U8 OnOff);
```

Parameters

Parameter	Description
<code>Unit</code>	Index of the sector map NOR driver (0-based).
<code>OnOff</code>	Specifies if the feature has to be enabled or disabled <ul style="list-style-type: none"> • =0 The write operation is not checked. • ≠0 The write operation is checked.

Additional information

This function is optional. The result of a page write operation is normally checked by evaluating the error bits maintained by the NOR flash device in a internal status register. `FS_NOR_SetWriteVerification()` can be used to enable additional verification of the page write operation that is realized by reading back the contents of the written page and by checking that all the bytes are matching the data requested to be written. Enabling this feature can negatively impact the write performance of sector map NOR driver.

The page write verification feature is active only when the sector map NOR driver is compiled with the `FS_NOR_VERIFY_WRITE` configuration define is set to 1 (default is 0) or when the `FS_DEBUG_LEVEL` configuration define is set to a value greater than or equal to `FS_DEBUG_LEVEL_CHECK_ALL`.

6.4.2.2.11 FS_NOR_STAT_COUNTERS

Description

Statistical counters maintained by the Sector Map NOR driver.

Type definition

```
typedef struct {
    U32  EraseCnt;
    U32  ReadSectorCnt;
    U32  WriteSectorCnt;
    U32  CopySectorCnt;
    U32  ReadCnt;
    U32  ReadByteCnt;
    U32  WriteCnt;
    U32  WriteByteCnt;
} FS_NOR_STAT_COUNTERS;
```

Structure members

Member	Description
EraseCnt	Number of sector erase operations.
ReadSectorCnt	Number of logical sectors read by the file system.
WriteSectorCnt	Number of logical sectors written by the file system.
CopySectorCnt	Number of logical sectors copied internally by the driver.
ReadCnt	Number of times the driver read data from the NOR flash device.
ReadByteCnt	Number of bytes read by the driver from the NOR flash device.
WriteCnt	Number of times the driver wrote data to the NOR flash device.
WriteByteCnt	Number of bytes written by the driver to the NOR flash device.

6.4.2.2.3 Additional sample configurations

The sample configurations below show how to create multiple volumes, logical volumes etc., on a NOR flash device. All configuration steps have to be performed inside the `FS_X_AddDevices()` function that is called during the initialization of the file system.

6.4.2.2.3.1 Multiple volumes on a single NOR flash device

The following example illustrates how to create multiple volumes on a single NOR flash device. The sample creates two volumes on one NOR flash device.

```
#include "FS.h"

#define ALLOC_SIZE 0x2000 // Size defined in bytes
//
// Config: 1 NOR flash, where NOR flash size -> 2 MB
//         2 volumes, , where volume 0 size -> 1MB, volume 1 -> 0.5MB
//
#define FLASH_BASE_ADDR 0x80000000
#define FLASH_VOLUME_0_START_ADDR 0x80000000
#define FLASH_VOLUME_0_SIZE 0x00100000 // 1 MByte
#define FLASH_VOLUME_1_START_ADDR 0x80100000
#define FLASH_VOLUME_1_SIZE 0x00080000 // 0.5 MByte

static U32 _aMemBlock[ALLOC_SIZE / 4]; // Memory pool used for
// semi-dynamic allocation.

/*****
 *
 * FS_X_AddDevices
 *
 * Function description
 * This function is called by the FS during FS_Init().
 */
void FS_X_AddDevices(void) {
    //
    // Give the file system memory to work with.
    //
    FS_AssignMemory(&_aMemBlock[0], sizeof(_aMemBlock));
    //
    // Volume name: "nor:0:"
    //
    FS_AddDevice(&FS_NOR_Driver);
    FS_NOR_SetPhyType(0, &FS_NOR_PHY_CFI_1x16);
    FS_NOR_Configure(0, FLASH_BASE_ADDR, FLASH_VOLUME_0_START_ADDR, FLASH_VOLUME_0_SIZE);
    //
    // Volume name: "nor:1:"
    //
    FS_AddDevice(&FS_NOR_Driver);
    FS_NOR_SetPhyType(1, &FS_NOR_PHY_CFI_1x16);
    FS_NOR_Configure(1, FLASH_BASE_ADDR, FLASH_VOLUME_1_START_ADDR, FLASH_VOLUME_1_SIZE);
}
```

6.4.2.2.3.2 Multiple volumes on different NOR flash devices

The following example illustrates how to create multiple volumes on multiple NOR flash devices. This sample creates two volume, each one located on different NOR flash device.

```
#include "FS.h"

#define ALLOC_SIZE 0x2000 // Size defined in bytes
//
// Config: 2 NOR flash devices, where NOR flash 0 size -> 2 MB, NOR flash 1 -> 16MB
//         2 volumes, volume 0 size -> complete NOR 0, volume 1 -> complete NOR 1
//
#define FLASH0_BASE_ADDR 0x80000000
#define FLASH_VOLUME_0_START_ADDR FLASH0_BASE_ADDR
#define FLASH_VOLUME_0_SIZE 0xFFFFFFFF // Use the complete flash
#define FLASH1_BASE_ADDR 0x40000000
#define FLASH_VOLUME_1_START_ADDR FLASH1_BASE_ADDR
#define FLASH_VOLUME_1_SIZE 0xFFFFFFFF // Use the complete flash
```

```

static U32 _aMemBlock[ALLOC_SIZE / 4]; // Memory pool used for
                                        // semi-dynamic allocation.

/*****
 *
 *      FS_X_AddDevices
 *
 *      Function description
 *      This function is called by the FS during FS_Init().
 */
void FS_X_AddDevices(void) {
    //
    // Give the file system memory to work with.
    //
    FS_AssignMemory(&_aMemBlock[0], sizeof(_aMemBlock));
    //
    // Volume name: "nor:0:"
    //
    FS_AddDevice(&FS_NOR_Driver);
    FS_NOR_SetPhyType(0, &FS_NOR_PHY_CFI_1x16);
    FS_NOR_Configure(0, FLASH0_BASE_ADDR, FLASH_VOLUME_0_START_ADDR, FLASH_VOLUME_0_SIZE);
    //
    // Volume name: "nor:1:"
    //
    FS_AddDevice(&FS_NOR_Driver);
    FS_NOR_SetPhyType(1, &FS_NOR_PHY_CFI_1x16);
    FS_NOR_Configure(1, FLASH1_BASE_ADDR, FLASH_VOLUME_1_START_ADDR, FLASH_VOLUME_1_SIZE);
}

```

6.4.2.2.3.3 Volume that stretches over multiple NOR flash devices

The following example illustrates how to create a volume that stretches over two NOR flash devices. This is realized by using the logical volume functionality.

```

#include "FS.h"

#define ALLOC_SIZE 0x2000 // Size defined in bytes
//
// Config: 2 NOR flash devices, where NOR flash 0 size -> 2 MB, NOR flash 1 -> 16MB
//         1 volume, where volume is NOR flash 0 + NOR flash 1
//
#define FLASH0_BASE_ADDR 0x80000000
#define FLASH_VOLUME_0_START_ADDR FLASH0_BASE_ADDR
#define FLASH_VOLUME_0_SIZE 0xFFFFFFFF // Use the complete flash
#define FLASH1_BASE_ADDR 0x40000000
#define FLASH_VOLUME_1_START_ADDR FLASH1_BASE_ADDR
#define FLASH_VOLUME_1_SIZE 0xFFFFFFFF // Use the complete flash

static U32 _aMemBlock[ALLOC_SIZE / 4]; // Memory pool used for
                                        // semi-dynamic allocation.

/*****
 *
 *      FS_X_AddDevices
 *
 *      Function description
 *      This function is called by the FS during FS_Init().
 */
void FS_X_AddDevices(void) {
    //
    // Give the file system memory to work with.
    //
    FS_AssignMemory(&_aMemBlock[0], sizeof(_aMemBlock));
    //
    // Create physical device 0, this device will not be visible as a volume.
    //
    FS_AddPhysDevice(&FS_NOR_Driver);
    FS_NOR_SetPhyType(0, &FS_NOR_PHY_CFI_1x16);
    FS_NOR_Configure(0, FLASH0_BASE_ADDR, FLASH_VOLUME_0_START_ADDR, FLASH_VOLUME_0_SIZE);
    //
    // Create physical device 1, this device will not be visible as a volume
    //
    FS_AddPhysDevice(&FS_NOR_Driver);
    FS_NOR_SetPhyType(1, &FS_NOR_PHY_CFI_1x16);
    FS_NOR_Configure(1, FLASH1_BASE_ADDR, FLASH_VOLUME_1_START_ADDR, FLASH_VOLUME_1_SIZE);
}

```

```
//  
// Now create a logical volume, containing the physical devices. Volume name: "LogVol"  
//  
FS_LOGVOL_Create("LogVol");  
FS_LOGVOL_AddDevice("LogVol", &FS_NOR_Driver, 0, 0, 0);  
FS_LOGVOL_AddDevice("LogVol", &FS_NOR_Driver, 1, 0, 0);  
}
```

6.4.2.3 Additional driver functions

The functions documented in this section are optional. They can be used to get information about the status of the Sector Map NOR driver or to directly access the data stored on the NOR flash device.

Function	Description
<code>FS_NOR_EraseDevice()</code>	Erases all the physical sectors configured as storage.
<code>FS_NOR_ErasePhySector()</code>	Sets all the bits in a physical sector to 1.
<code>FS_NOR_FormatLow()</code>	Performs a low-level format of NOR flash device.
<code>FS_NOR_GetDiskInfo()</code>	Returns information about the organization and the management of the NOR flash device.
<code>FS_NOR_GetSectorInfo()</code>	Returns information about a specified physical sector.
<code>FS_NOR_GetStatCounters()</code>	Returns the values of the statistical counters.
<code>FS_NOR_IsLLFormatted()</code>	Checks if the NOR flash is low-level formatted.
<code>FS_NOR_LogSector2PhySectorAddr()</code>	Returns the address in memory of a specified logical sector.
<code>FS_NOR_ReadOff()</code>	Reads a range of bytes from the NOR flash device.
<code>FS_NOR_ResetStatCounters()</code>	Sets the value of the statistical counters to 0.
<code>FS_NOR_WriteOff()</code>	Writes data to NOR flash memory.

6.4.2.3.1 FS_NOR_EraseDevice()

Description

Erases all the physical sectors configured as storage.

Prototype

```
int FS_NOR_EraseDevice(U8 Unit);
```

Parameters

Parameter	Description
Unit	Index of the sector map NOR driver (0-based).

Return value

= 0 Physical sectors erased.
≠ 0 An error occurred.

Additional information

This function is optional. After the call to this function all the bytes in area of the NOR flash device configured as storage are set to 0xFF.

6.4.2.3.2 FS_NOR_ErasePhySector()

Description

Sets all the bits in a physical sector to 1.

Prototype

```
int FS_NOR_ErasePhySector(U8 Unit,  
                          U32 PhySectorIndex);
```

Parameters

Parameter	Description
Unit	Index of the Block Map NOR driver (0-based).
PhySectorIndex	Index of the physical sector to be erased.

Return value

= 0 OK, physical sector erased successfully.
≠ 0 An error occurred.

Additional information

[PhySectorIndex](#) is 0-based and is relative to the beginning of the NOR flash area configured via [FS_NOR_Configure\(\)](#). The number of bytes actually erased depends on the size of the physical sector supported by the NOR flash device. Information about a physical sector can be obtained via [FS_NOR_GetSectorInfo\(\)](#).

6.4.2.3.3 FS_NOR_FormatLow()

Description

Performs a low-level format of NOR flash device.

Prototype

```
int FS_NOR_FormatLow(U8 Unit);
```

Parameters

Parameter	Description
Unit	Index of the sector map NOR driver (0-based).

Return value

= 0 OK, NOR flash device has been successfully low-level formatted.
≠ 0 An error occurred.

Additional information

This function is optional. `FS_NOR_FormatLow()` erases the first physical sector and stores the format information in it. The other physical sectors are either erased or invalidated. Per default the physical sectors are invalidated in order to reduce the time it takes for the operation to complete.

6.4.2.3.4 FS_NOR_GetDiskInfo()

Description

Returns information about the organization and the management of the NOR flash device.

Prototype

```
int FS_NOR_GetDiskInfo(U8 Unit,
                      FS_NOR_DISK_INFO * pDiskInfo);
```

Parameters

Parameter	Description
Unit	Index of the sector map NOR driver (0-based).
pDiskInfo	out Requested information.

Return value

= 0 OK, information returned.
 ≠ 0 An error occurred.

Additional information

This function is not required for the functionality of the sector map NOR driver and will typically not be linked in production builds.

Example

```
#include "FS.h"

void SampleNORGetDiskInfo(void) {
    int r;
    char ac[128];
    FS_NOR_DISK_INFO DiskInfo;

    FS_X_Log("Get information about the first Sector Map NOR driver instance\n");
    r = FS_NOR_GetDiskInfo(0, &DiskInfo);
    if (r == 0) {
        SEGGER_sprintf(ac, sizeof(ac), " Physical sectors: %lu\n", DiskInfo.NumPhysSectors);
        FS_X_Log(ac);
        SEGGER_sprintf(ac, sizeof(ac), " Logical sectors : %lu\n", DiskInfo.NumLogSectors);
        FS_X_Log(ac);
        SEGGER_sprintf(ac, sizeof(ac), " Used sectors:      %lu\n", DiskInfo.NumUsedSectors);
        FS_X_Log(ac);
    }
}
```

6.4.2.3.5 FS_NOR_GetSectorInfo()

Description

Returns information about a specified physical sector.

Prototype

```
int FS_NOR_GetSectorInfo(U8          Unit,
                        U32          PhySectorIndex,
                        FS_NOR_SECTOR_INFO * pSectorInfo);
```

Parameters

Parameter	Description
<code>Unit</code>	Index of the sector map NOR driver (0-based).
<code>PhySectorIndex</code>	Index of the physical sector to be queried (0-based).
<code>pSectorInfo</code>	out Information related to the specified physical sector.

Return value

= 0 OK, information returned successfully.
 ≠ 0 An error occurred.

Additional information

This function is optional. The application can use it to get information about the usage of a particular physical sector.

`PhySectorIndex` is relative to the beginning of the region configured as storage via `FS_NOR_Configure()`.

Example

```
#include "FS.h"

void SampleNORGetDiskInfo(void) {
    char          ac[128];
    FS_NOR_SECTOR_INFO SectorInfo;

    FS_X_Log("Get information about the physical sector 0 of the first Sector Map NOR driver
instance\n");
    FS_NOR_GetSectorInfo(0, 0, &SectorInfo);
    SEGGER_sprintf(ac, sizeof(ac), " Offset:           %lu\n", SectorInfo.Off);
    FS_X_Log(ac);
    SEGGER_sprintf(ac, sizeof(ac), " Size:           %lu bytes
\n", SectorInfo.Size);
    FS_X_Log(ac);
    SEGGER_sprintf(ac, sizeof(ac), " Erase count:     %lu\n", SectorInfo.EraseCnt);
    FS_X_Log(ac);
    SEGGER_sprintf(ac, sizeof(ac), " Used logical sectors: %lu
\n", SectorInfo.NumUsedSectors);
    FS_X_Log(ac);
    SEGGER_sprintf(ac, sizeof(ac), " Free logical sectors: %lu
\n", SectorInfo.NumFreeSectors);
    FS_X_Log(ac);
    SEGGER_sprintf(ac, sizeof(ac), " Erasable logical sectors: %lu
\n", SectorInfo.NumErasableSectors);
    FS_X_Log(ac);
}
```

6.4.2.3.6 FS_NOR_GetStatCounters()

Description

Returns the values of the statistical counters.

Prototype

```
void FS_NOR_GetStatCounters(U8 Unit,
                             FS_NOR_STAT_COUNTERS * pStat);
```

Parameters

Parameter	Description
<code>Unit</code>	Index of the sector map NOR driver (0-based).
<code>pStat</code>	<code>out</code> Statistical counter values.

Additional information

This function is optional. The application can use it to get the actual values of the statistical counters maintained by the sector map NOR driver. The statistical counters provide information about the number of internal operations performed by the sector map NOR driver such as sector read and write. All statistical counters are set to 0 when the NOR flash device is low-level mounted. The application can explicitly set them to 0 by using `FS_NOR_ResetStatCounters()`. A separate set of statistical counters is maintained for each instance of the sector map NOR driver.

The statistical counters are available only when the sector map NOR driver is compiled with the `FS_DEBUG_LEVEL` configuration define set to a value greater than or equal to `FS_DEBUG_LEVEL_CHECK_ALL` or with the `FS_NOR_ENABLE_STATS` configuration define set to 1.

6.4.2.3.7 FS_NOR_IsLLFormatted()

Description

Checks if the NOR flash is low-level formatted.

Prototype

```
int FS_NOR_IsLLFormatted(U8 Unit);
```

Parameters

Parameter	Description
Unit	Index of the sector map NOR driver (0-based).

Return value

- ≠ 0 The NOR flash device is low-level formatted.
- = 0 The NOR flash device is not low-level formatted or an error has occurred.

Additional information

This function is optional. An application should use `FS_IsLLFormatted()` instead.

6.4.2.3.8 FS_NOR_LogSector2PhySectorAddr()

Description

Returns the address in memory of a specified logical sector.

Prototype

```
void *FS_NOR_LogSector2PhySectorAddr(U8 Unit,  
                                     U32 LogSectorIndex);
```

Parameters

Parameter	Description
<code>Unit</code>	Index of the sector map NOR driver (0-based).
<code>LogSectorIndex</code>	Index of the logical sector for which the address has to be calculated.

Return value

≠ NULL OK, address of the first byte in the logical sector.
= NULL An error occurred.

Additional information

This function is optional. It can be used only with NOR flash devices that are memory mapped. `FS_NOR_LogSector2PhySectorAddr()` returns the address in the system memory of the first byte in the specified logical sector.

6.4.2.3.9 FS_NOR_ReadOff()

Description

Reads a range of bytes from the NOR flash device.

Prototype

```
int FS_NOR_ReadOff(U8      Unit,  
                  U32      Off,  
                  void *  pData,  
                  U32      NumBytes);
```

Parameters

Parameter	Description
<code>Unit</code>	Index of the sector map NOR driver (0-based).
<code>Off</code>	Offset of the first byte to be read.
<code>pData</code>	<code>out</code> Read data.
<code>NumBytes</code>	Number of bytes to be read.

Return value

= 0 OK, data read.
≠ 0 An error occurred.

Additional information

This function is not required for the functionality of the driver and will typically not be linked in production builds.

`Off` has to be specified in bytes and is relative to the beginning of the NOR flash area configured via `FS_NOR_Configure()`.

6.4.2.3.10 FS_NOR_ResetStatCounters()

Description

Sets the value of the statistical counters to 0.

Prototype

```
void FS_NOR_ResetStatCounters(U8 Unit);
```

Parameters

Parameter	Description
Unit	Index of the sector map NOR driver (0-based).

Additional information

This function is optional. The application can use it to set the statistical counters maintained by the sector map NOR driver to 0. The statistical counters can be read via `FS_NOR_GetStatCounters()`

`FS_NOR_ResetStatCounters()` is available only when the sector map NOR driver is compiled with the `FS_DEBUG_LEVEL` configuration define set to a value greater than or equal to `FS_DEBUG_LEVEL_CHECK_ALL` or with the `FS_NOR_ENABLE_STATS` configuration define set to 1.

6.4.2.3.11 FS_NOR_WriteOff()

Description

Writes data to NOR flash memory.

Prototype

```
int FS_NOR_WriteOff(    U8      Unit,
                       U32      Off,
                       const void * pData,
                       U32      NumBytes);
```

Parameters

Parameter	Description
<code>Unit</code>	Index of the Sector Map NOR driver (0-based).
<code>Off</code>	Location where to write the data.
<code>pData</code>	in Data to be written.
<code>NumBytes</code>	Number of bytes to be written.

Return value

= 0 OK, data written successfully.
 ≠ 0 An error occurred.

Additional information

`Off` has to be specified in bytes and is relative to the beginning of the NOR flash area configured via `FS_NOR_Configure()`.

`FS_NOR_WriteOff()` is able to write across page and physical sector boundaries. This function can only change bit values from 1 to 0. The bits can be set to 1 block-wise via `FS_NOR_ErasePhySector()`.

The function takes care of the alignment required when writing to NOR flash devices with line size larger than 1.

6.4.2.3.12 FS_NOR_DISK_INFO

Description

Management information maintained by the Sector Map NOR driver.

Type definition

```
typedef struct {  
    U32  NumPhysSectors;  
    U32  NumLogSectors;  
    U32  NumUsedSectors;  
    U16  BytesPerSector;  
} FS_NOR_DISK_INFO;
```

Structure members

Member	Description
NumPhysSectors	Number of physical sectors available for data storage.
NumLogSectors	Number of available logical sectors.
NumUsedSectors	Number of logical sectors that store valid data.
BytesPerSector	Size of the logical sector used by the driver in bytes.

6.4.2.3.13 FS_NOR_SECTOR_INFO

Description

Information about a physical sector maintained by the Sector Map NOR driver.

Type definition

```
typedef struct {
    U32  Off;
    U32  Size;
    U32  EraseCnt;
    U16  NumUsedSectors;
    U16  NumFreeSectors;
    U16  NumEraseableSectors;
    U8   Type;
} FS_NOR_SECTOR_INFO;
```

Structure members

Member	Description
Off	Position of the physical sector relative to the first byte of NOR flash device
Size	Size of physical sector in bytes
EraseCnt	Number of times the physical sector has been erased
NumUsedSectors	Number of logical sectors that contain valid data
NumFreeSectors	Number of logical sectors that are empty (i.e. blank)
NumEraseableSectors	Number of logical sectors that contain old (i.e. invalid) data.
Type	Type of data stored in the physical sector (see FS_NOR_SECTOR_TYPE...)

6.4.2.4 Performance and resource usage

This section provides information about the ROM and RAM usage as well as the performance of the Sector Map NOR driver. Each driver instance requires one instance of one NOR physical layer in order to operate. The resource usage of the used NOR physical layer has to be taken into account when calculating the total resource usage of the Sector Map NOR driver. Refer to the section *Resource usage* on page 897 for information about the resource usage of the available NOR physical layers.

6.4.2.4.1 ROM usage

The ROM usage depends on the compiler options, the compiler version and the used CPU. The memory requirements of the Sector Map NOR driver were measured as described in the section *Test procedure* on page 1283.

Usage: 4.0 Kbytes

6.4.2.4.2 Static RAM usage

Static RAM usage refers to the amount of RAM required by the Sector Map NOR driver internally for all the driver instances. The number of bytes can be seen in the compiler list file of the `FS_NOR_Drv.c` file.

Usage: 20 bytes

6.4.2.4.3 Dynamic RAM usage

Dynamic RAM usage is the amount of RAM allocated by the driver at runtime. The amount of RAM required depends on the runtime configuration and on the used NOR flash device. The approximate RAM usage of the Sector Map NOR driver can be calculated as follows:

```
MemAllocated = 500 + (BitsPerEntry * FlashSize / 8) / LogSectorSize
```

Parameter	Description
MemAllocated	Number of bytes allocated.
BitsPerEntry	Number of bits required to store the offset of the last byte on the storage.
FlashSize	Size in bytes of a NOR flash.
LogSectorSize	Size in bytes of a file system sector. Typically, 512 bytes or the value set in the call to <code>FS_SetMaxSectorSize()</code> .

The following table lists the approximate amount of RAM required for different combinations of NOR flash size and logical sector size:

Flash size (Mbytes)	512 byte sectors	1 Kbyte sectors	2 Kbyte sectors
1	4.6 KBytes	2.5 KBytes	1.5 KBytes
2	8.7 KBytes	4.6 KBytes	2.5 KBytes
4	16.8 KBytes	8.7 KBytes	4.6 KBytes
8	33.2 KBytes	16.8 KBytes	8.7 KBytes

Note

Please note that by increasing the logical sector size the RAM usage of the file system increases too because more memory is required for the sector buffers.

6.4.2.4.4 Performance

These performance measurements are in no way complete, but they give an approximation of the length of time required for common operations on various targets. The tests were

performed as described in the section *Performance* on page 1289. All values are given in Kbytes/second

CPU type	NOR flash device	Write speed	Read speed
ST STR912 (96 MHz)	Winbond W25Q32BV (SPI)	75	2625
NXP LPC2478 (57.6 MHz)	SST SST39VF201 CFI NOR flash device with 16-bit interface and without support for write buffer	53.5	2560
ST STM32F103 (72 MHz)	ST M29W128 CFI NOR flash device 16-bit interface and with support for write buffer	60.4	8000
ST STM32F103 (72 MHz)	ST M25P64 SPI NOR flash device	62.8	1125
NXP LPC4357 (204 MHz)	Spansion S25FL032P serial NOR flash device interfaced via SPIFI.	185	26947

6.4.2.5 FAQs

Q: How many physical sectors are reserved by the driver?

A: The driver reserves 2 physical sectors for its internal use.

6.4.3 Block Map NOR driver

This section describes the NOR driver which is optimized for reduced RAM usage. It works by mapping blocks of logical sectors to physical sectors of the NOR flash device.

6.4.3.1 Theory of operation

Differentiating between logical sectors or blocks and physical sectors is essential to understand this section. A logical sector or block is the smallest readable and writable unit of any file system and its usual size is 512 bytes. A physical sector is an array of bytes on the NOR flash device that are erased together (typically between 2 Kbytes - 128 Kbytes). The NOR flash driver is an abstraction layer between these two types of sectors.

The Block Map NOR driver maintains a table that maps ranges of logical sectors, called logical blocks, to physical sectors on the NOR flash device. The number of logical sectors in a logical block depends on how many logical sectors fit in a physical sector. Every time a logical sector is updated, its content is written to a special physical sector called work block. A work block is a kind of temporary storage for the modified data of a logical sector that is later converted into a data block when a new empty work block needs to be allocated.

6.4.3.2 Configuring the driver

The Block Map NOR driver has to be configured at runtime and optionally at compile time. The following sections described how this can be realized in the application.

6.4.3.2.1 Compile time configuration

The Block Map NOR driver can optionally be configured at compile time. Typically, this step can be omitted because reasonable default values are provided that work with most of the applications. The compile time configuration is realized via preprocessor defines that have to be added to the `FS_Conf.h` file which is the main configuration file of emFile. For detailed information about the configuration of emFile and of the configuration define types, refer to *Configuration of emFile* on page 1218. The following table lists the configuration defines supported by the Block Map NOR driver.

Define	Default value	Type	Description
<code>FS_NOR_CAN_REWRITE</code>	1	B	Specifies if modifying the same byte on the NOR flash device more than one time is permitted.
<code>FS_NOR_CRC_HOOK_DEFAULT</code>	<code>&FS_NOR_CRC_SW</code>	R	Specifies the default routines to be used for the CRC calculation.
<code>FS_NOR_DATA_BUFFER_SIZE</code>	32	N	Number of bytes to be reserved for the data buffers used for internal operations.
<code>FS_NOR_ECC_HOOK_DATA_DEFAULT</code>	<code>&FS_NOR_ECC_SW_1bit_Data</code>	R	Specifies the default routines to be used for the ECC calculation of the sector data.
<code>FS_NOR_ECC_HOOK_MAN_DEFAULT</code>	<code>&FS_NOR_ECC_SW_1bit_Man</code>	R	Specifies the default routines to be used for the ECC calculation of the management data.
<code>FS_NOR_ENABLE_STATS</code>	0 or 1	B	Enables or disables the support for statistical counters.
<code>FS_NOR_LINE_SIZE</code>	1	N	Configures the minimum number of bytes to write at once.
<code>FS_NOR_LOG_SECTOR_RESERVE</code>	4	N	Configures additional space to be reserved for the management data of a logical sector.

Define	Default value	Type	Description
FS_NOR_MAX_ERASE_CNT	500000	N	Configures the maximum value of a valid erase count.
FS_NOR_MAX_ERASE_CNT_DIFF	5000	N	Configures the default maximum difference between erase counts.
FS_NOR_NUM_READ_RETRIES	10	N	Configures the number of retries in case of a read error.
FS_NOR_NUM_WRITE_RETRIES	10	N	Configures the number of retries in case of a write error.
FS_NOR_NUM_UNITS	4	N	Configures the maximum number of driver instances.
FS_NOR_OPTIMIZE_EMPTY_CHECK	0	B	Enables or disables the optimization for the checking of the physical sector empty status.
FS_NOR_OPTIMIZE_HEADER_WRITE	0	B	Enables or disables the optimization for the writing of management data.
FS_NOR_OPTIMIZE_DATA_WRITE	1	B	Enables or disables the optimization for the writing of logical sector data.
FS_NOR_PHY_SECTOR_RESERVE	8	N	Configures additional space to be reserved for the management data of a physical sector.
FS_NOR_READ_BUFFER_FILL_PATTERN	0xFF	N	Configures a bit pattern to be used for filling the contents of invalid logical sectors.
FS_NOR_SKIP_BLANK_SECTORS	1	B	Enables or disables the support for erasing blank physical sectors at low-level format.
FS_NOR_STRICT_FORMAT_CHECK	0	N	Enables or disables additional checks related to the low-level format.
FS_NOR_SUPPORT_CLEAN	1	B	Enables or disables the support for executing the garbage collection in the application.
FS_NOR_SUPPORT_CRC	0	B	Enables or disables the support for data integrity verification via CRC of payload and management data.
FS_NOR_SUPPORT_ECC	0	B	Enables or disables the support for data integrity verification via ECC of payload and management data.
FS_NOR_SUPPORT_FORMAT	1	B	Enables or disables the support for low-level formatting.
FS_NOR_SUPPORT_TRIM	1	B	Enables or disables the support for marking logical sectors are not being in use.
FS_NOR_SUPPORT_VARIABLE_BYTE_ORDER	0	B	Enables or disables the support for configuring at runtime the byte order of management data.
FS_NOR_SUPPORT_VARIABLE_LINE_SIZE	0	B	Enables or disables the support for configuring at runtime the

Define	Default value	Type	Description
			minimum number of bytes to be written at once.
FS_NOR_VERIFY_WRITE	0	B	Enables or disables the support for checking if the write operation was successful.
FS_NOR_VERIFY_ERASE	0	B	Enables or disables the support for checking if the erase operation was successful.

6.4.3.2.1.1 FS_NOR_CAN_REWRITE

For the majority of NOR flash device the same byte can be modified more than once without a erase operation in between while preserving the bits set to 0. That is a byte can be written up to eight times with each write operation setting a different bit in that byte to 0. The Block Map NOR driver makes use of this feature to make efficient use of the storage space and to improve the performance. `FS_NOR_CAN_REWRITE` has to be set to 0 for NOR flash devices that permit only one write operation to a byte or a range of bytes between two erase operations of that storage block.

6.4.3.2.1.2 FS_NOR_CRC_HOOK_DEFAULT

This define specifies the default routines for the CRC calculation. It can be set to `NULL` in order to save ROM space if the application registers its own routines via `FS_NOR_BM_SetCRCHook()`

6.4.3.2.1.3 FS_NOR_DATA_BUFFER_SIZE

This define can be used to specify the size of the buffers used by the Block Map NOR driver for internal operations such as copying the contents of a logical sector or verifying if a physical sector is blank. All these buffers are allocated on the stack therefore increasing the value of `FS_NOR_DATA_BUFFER_SIZE` increases the stack usage while providing a better performance. `FS_NOR_DATA_BUFFER_SIZE` has to be a non-zero value multiple of 4.

If the file system is built with `FS_SUPPORT_EXT_MEM_MANAGER` set to 0 then the Block Map NOR driver is using as buffer the available free memory at the time the buffer is required if the number of free bytes is larger than `FS_NOR_DATA_BUFFER_SIZE`. This means that it is possible to reduce the stack usage by setting `FS_NOR_DATA_BUFFER_SIZE` to a smaller value than the default and by increasing the size of the memory pool assigned to the file system via `FS_AssignMemory()` by the amount of memory required for the buffer.

6.4.3.2.1.4 FS_NOR_ECC_HOOK_DATA_DEFAULT

This define specifies the default routines for the ECC calculation of sector data. It can be set to `NULL` in order to save ROM space if the application registers its own routines via `FS_NOR_BM_SetECCHook()`

6.4.3.2.1.5 FS_NOR_ECC_HOOK_MAN_DEFAULT

This define specifies the default routines for the ECC calculation of the management data. It can be set to `NULL` in order to save ROM space if the application registers its own routines via `FS_NOR_BM_SetECCHook()`

6.4.3.2.1.6 FS_NOR_ENABLE_STATS

This define can be used to enable the support for statistical counters. The statistical counters provide information about the number of operations performed internally by the Block Map NOR driver that can be useful for debugging. The statistical counters can be queried via `FS_NOR_BM_GetStatCounters()`. By default `FS_NOR_ENABLE_STATS` is set to 1 if `FS_DEBUG_LEVEL` is set to a value greater than or equal to `FS_DEBUG_LEVEL_CHECK_ALL`.

6.4.3.2.1.7 FS_NOR_LINE_SIZE

`FS_NOR_LINE_SIZE` specifies the minimum number of bytes the Block Map NOR driver writes at once. The amount of data written is always a multiple of this value. In addition, `FS_NOR_LINE_SIZE` specifies the alignment of the written data. That is the offset at which the Block Map NOR driver writes the data is always a multiple of this value. `FS_NOR_LINE_SIZE` has to be a power of two value.

6.4.3.2.1.8 FS_NOR_LOG_SECTOR_RESERVE

This define can be used to specify the number of additional bytes to be allocated for the management data of a logical sector. The NOR flash device has to be low-level formatted after `FS_NOR_LOG_SECTOR_RESERVE` is modified. `FS_NOR_LOG_SECTOR_RESERVE` exists for backward compatibility reasons with older emFile versions. Typically, the default value of `FS_NOR_LOG_SECTOR_RESERVE` does not have to be modified. `FS_NOR_LOG_SECTOR_RESERVE` must be a multiple of 4 bytes.

6.4.3.2.1.9 FS_NOR_MAX_ERASE_CNT

The Block Map NOR driver uses the value of `FS_NOR_MAX_ERASE_CNT` to check the validity of an erase count stored in the header of a physical sector. If the value of the erase count is larger than `FS_NOR_MAX_ERASE_CNT` then the erase count is considered invalid and is set to the maximum value of all valid erase counts.

6.4.3.2.1.10 FS_NOR_MAX_ERASE_CNT_DIFF

The value of this define is used by the Block Map NOR driver during the wear leveling procedure to decide which physical sector has to be used for storage. `FS_NOR_BM_SetMaxEraseCntDiff()` can be used to modify this value at runtime. Refer to *Wear Leveling* on page 731 for more information about how this value is used.

6.4.3.2.1.11 FS_NOR_NUM_READ_RETRIES

`FS_NOR_NUM_READ_RETRIES` specifies the maximum number of times the Block Map NOR driver repeats a read operation in case of an error. A read retry is performed each time the read function of the NOR physical layer reports an error or if the CRC feature is activated when the CRC verification fails. `NumReadRetries` of `FS_NOR_BM_STAT_COUNTERS` is incremented by 1 on each retry.

6.4.3.2.1.12 FS_NOR_NUM_WRITE_RETRIES

`FS_NOR_NUM_WRITE_RETRIES` specifies the maximum number of times the Block Map NOR driver repeats a write operation in case of an error. A write retry is performed each time the write function of the NOR physical layer reports an error.

6.4.3.2.1.13 FS_NOR_NUM_UNITS

This define specifies the maximum number of driver instances of the Block Map NOR driver the application is allowed create. Four bytes of static RAM are reserved for each instance. If the maximum number of driver instances is smaller than the default then `FS_NOR_NUM_UNITS` can be set to the to that value in order to reduce the RAM usage.

6.4.3.2.1.14 FS_NOR_OPTIMIZE_EMPTY_CHECK

This configuration define can be used to enable an optimization that reduces the number of read operations performed by the Block Map NOR driver when it checks if a physical sector can be used to write data to it without being erased first. Setting `FS_NOR_OPTIMIZE_EMPTY_CHECK` to 1 has effect only if either `FS_NOR_SUPPORT_CLEAN` or `FS_NOR_SKIP_BLANK_SECTORS` are set to 1 and the support for fail-safe erase operation is disabled.

6.4.3.2.1.15 FS_NOR_OPTIMIZE_HEADER_WRITE

`FS_NOR_OPTIMIZE_HEADER_WRITE` can be used to specify how the management data is written to storage. The management data is stored at the beginning of each physical and logical

sector in an area called header. By default, the size of the physical sector header is 16 bytes and of the logical sector header is 8 bytes. The size of these headers is larger for NOR flash devices that specify a minimum number of bytes that have to be written at once and that are not able to perform incremental write operations. The default behavior of the Block Map NOR driver, that is when `FS_NOR_OPTIMIZE_HEADER_WRITE` is set to 0, is to write the entire header every time some of the information stored in it changes. With `FS_NOR_OPTIMIZE_HEADER_WRITE` set to 1 the Block Map NOR driver tracks the changes made to a header and writes only the information that actually changed. Reducing the amount of data written to storage can help increase the write performance.

The internal flash memory of some MCUs do not allow a second write operation to the same byte with identical data without an erase operation in between. If this type of flash memory is used as storage then it is mandatory to set `FS_NOR_OPTIMIZE_HEADER_WRITE` to 1.

6.4.3.2.1.16 FS_NOR_OPTIMIZE_DATA_WRITE

This configuration define can be used to enable an optimization that can help increase the performance of the write operation. With `FS_NOR_OPTIMIZE_DATA_WRITE` set to 1 the Block Map NOR driver tries to write the sector data directly to a data block instead of writing it first to a work block. In this way the total number of write operations is reduced, which as a side effect helps extend the lifetime of NOR flash device. Enabling this optimization increases the RAM and ROM usage of the Block Map NOR driver.

6.4.3.2.1.17 FS_NOR_PHY_SECTOR_RESERVE

This define can be used to specify the number of additional bytes to be allocated for the management data of a physical sector. The NOR flash device has to be low-level formatted after `FS_NOR_PHY_SECTOR_RESERVE` is modified. `FS_NOR_PHY_SECTOR_RESERVE` exists for backward compatibility reasons with older emFile versions. Typically, the default value of `FS_NOR_PHY_SECTOR_RESERVE` does not have to be modified. `FS_NOR_PHY_SECTOR_RESERVE` must be a multiple of 4 bytes.

6.4.3.2.1.18 FS_NOR_READ_BUFFER_FILL_PATTERN

The value of `FS_NOR_READ_BUFFER_FILL_PATTERN` is used by the Block Map NOR driver to fill the contents of invalid logical sectors that is logical sectors that were not written yet. The contents of all logical sectors is invalid after a low-level format operation. In addition, the contents of a logical sector can be invalidated via `FS_STORAGE_FreeSectors()`.

6.4.3.2.1.19 FS_NOR_SKIP_BLANK_SECTORS

`FS_NOR_SKIP_BLANK_SECTORS` can be used to enable the support for the optimization that omits the erase of physical sectors that are already blank. This feature has to be explicitly enabled a runtime by calling `FS_NOR_BM_SetBlankSectorSkip()`.

6.4.3.2.1.20 FS_NOR_STRICT_FORMAT_CHECK

`FS_NOR_STRICT_FORMAT_CHECK` can be used to enable additional checks related to the low-level formatting of the NOR flash device. If `FS_NOR_STRICT_FORMAT_CHECK` is set to 1 then the Block Map NOR driver checks at low-level mount if the number of logical blocks stored during the last low-level format operation matches the actual number of logical blocks available for storage. The low-level format operation fails if the number of logical blocks is not equal that for example triggers a low-level format operation if the application calls `FS_FormatLLIfRequired()`

This can be useful in a situation where an already low-level formatted NOR partition is enlarged. With `FS_NOR_STRICT_FORMAT_CHECK` set to 0 the low-level mount operation succeeds and the Block Map NOR driver will not use the additional space as storage. A low-level mount operation fails when an already formatted NOR partition is shrunk irrespective of the value of `FS_NOR_STRICT_FORMAT_CHECK`.

6.4.3.2.1.21 FS_NOR_SUPPORT_CLEAN

This define specifies if the application is allowed to perform a garbage collection operation. If `FS_NOR_SUPPORT_CLEAN` is set to 1 then the application can perform a garbage collec-

tion operation via `FS_STORAGE_Clean()` and `FS_STORAGE_CleanOne()`. For more information about the garbage collection refer to *Garbage collection* on page 730. The automatic garbage collection operation performed by the Block Map NOR driver is not disabled when `FS_NOR_SUPPORT_CLEAN` is set to 0. If the application does not call either `FS_STORAGE_Clean()` or `FS_STORAGE_CleanOne()` then `FS_NOR_SUPPORT_CLEAN` can be safely set to 0 in order to save ROM space.

6.4.3.2.1.22 FS_NOR_SUPPORT_CRC

`FS_NOR_SUPPORT_CRC` can be used to enable the support for the CRC verification. This feature has to be enabled at runtime via `FS_NOR_BM_EnableCRC()`. For more information about the CRC feature refer to *CRC verification* on page 731

6.4.3.2.1.23 FS_NOR_SUPPORT_ECC

`FS_NOR_SUPPORT_ECC` can be used to enable the support for the ECC verification. This feature has to be enabled at runtime via `FS_NOR_BM_EnableECC()`. For more information about the ECC feature refer to *Bit error correction* on page 732

6.4.3.2.1.24 FS_NOR_SUPPORT_FORMAT

`FS_NOR_SUPPORT_FORMAT` can be used to disable the support for the low-level format operation. The ability of the Block Map NOR driver to perform a low-level format operation is not required if the NOR flash device is already formatted for example by storing a file system image via an external utility to it. In such a case `FS_NOR_SUPPORT_FORMAT` can be set to 0 to reduce the ROM usage.

6.4.3.2.1.25 FS_NOR_SUPPORT_TRIM

`FS_NOR_SUPPORT_TRIM` can be used to enable or disable the handling of file system operations that inform the Block Map NOR driver about logical sectors that are no longer in use. The Block Map NOR driver can use this information to optimize the internal operation that copies the data from one physical sector to another by not copying the contents of the logical sectors that are marked as being no longer in use. Enabling this feature increases the ROM usage of the Block Map NOR driver.

6.4.3.2.1.26 FS_NOR_SUPPORT_VARIABLE_BYTE_ORDER

This define can be used to specify if the byte order of the management data can be configured at runtime or not. By default, multi-byte management data is stored in the native order of the MCU on which the target application is running. With `FS_NOR_SUPPORT_VARIABLE_BYTE_ORDER` set to 1 the byte order can be configured at runtime via `FS_NOR_BM_SetByteOrderLE()` and `FS_NOR_BM_SetByteOrderBE()`.

`FS_NOR_SUPPORT_VARIABLE_BYTE_ORDER` is set to 1 when building the NOR Image Creator utility in order to give it the ability to create images for a MCU with a different byte ordering than of the host PC. Typically, there is no need to modify the default value of `FS_NOR_SUPPORT_VARIABLE_BYTE_ORDER` when building a target application.

6.4.3.2.1.27 FS_NOR_SUPPORT_VARIABLE_LINE_SIZE

`FS_NOR_SUPPORT_VARIABLE_LINE_SIZE` can be used to enable the runtime configuration of the minimum number of bytes to be written by the Block Map NOR driver at once. With `FS_NOR_SUPPORT_VARIABLE_LINE_SIZE` set to 1 the minimum number of bytes to be written at once can be configured via `FS_NOR_BM_SetDeviceLineSize()` between 1 and `FS_NOR_LINE_SIZE`. In addition, the ability of the NOR flash device to perform incremental write operations can be configured via `FS_NOR_BM_SetDeviceRewriteSupport()`.

`FS_NOR_SUPPORT_VARIABLE_LINE_SIZE` is set to 1 when building the NOR Image Creator utility in order to give it the ability to create images for NOR flash devices with different characteristics. Typically, there is no need to modify the default value of `FS_NOR_SUPPORT_VARIABLE_LINE_SIZE` when building a target application.

6.4.3.2.1.28 FS_NOR_VERIFY_WRITE

This define can be used to activate the write verification of the Block Map NOR driver. The write verification is performed after each write operation by reading back the modified data from storage and by comparing it with the data requested to be written. An error is reported if a difference is detected. This feature has to be enabled at runtime by calling `FS_NOR_BM_SetWriteVerification()`.

Note

Activating the write verification can negatively affect the write performance.

6.4.3.2.1.29 FS_NOR_VERIFY_ERASE

This define can be used to activate the erase verification of the Block Map NOR driver. The erase verification is performed after each erase operation by reading back the entire data of the erase physical sector from storage and by comparing it with `0xFF`. An error is reported if a difference is detected. This feature has to be enabled at runtime by calling `FS_NOR_BM_SetWriteVerification()`.

Note

Activating the erase verification can negatively affect the write performance.

6.4.3.2.2 Runtime configuration

The driver must be added to the file system by calling `FS_AddDevice()` with the driver identifier set to the address of `FS_NOR_BM_Driver`. This function call together with other function calls that configure the driver operation have to be added to `FS_X_AddDevices()` as demonstrated in the following example. This example shows how to configure the file system to access a NOR flash device connected via SPI.

```
#include "FS.h"

#define ALLOC_SIZE 0x4000 // Size defined in bytes

static U32 _aMemBlock[ALLOC_SIZE / 4]; // Memory pool used for
// semi-dynamic allocation.

/*****
 *
 * FS_X_AddDevices
 *
 * Function description
 * This function is called by the FS during FS_Init().
 */
void FS_X_AddDevices(void) {
    //
    // Give the file system memory to work with.
    //
    FS_AssignMemory(&_aMemBlock[0], sizeof(_aMemBlock));
    //
    // Add and configure the NOR flash driver. The first 65536 bytes of the
    // serial NOR flash device are not used by the file system as data storage
    // and can be used by the application for other purposes. The file system
    // uses a total of 1 Mbyte from the serial NOR flash device as storage.
    //
    FS_AddDevice(&FS_NOR_BM_Driver);
    FS_NOR_BM_SetPhyType(0, &FS_NOR_PHY_ST_M25);
    FS_NOR_BM_Configure(0, 0x00000000, 0x00010000, 0x00100000);
}
```

The API functions listed in the next table can be used by the application to configure the behavior of the Block Map NOR driver. The application can call them only at the file system initialization in `FS_X_AddDevices()`.

Function	Description
<code>FS_NOR_BM_Configure()</code>	Configures an instance of the Block Map NOR driver.
<code>FS_NOR_BM_DisableCRC()</code>	Disables the data integrity check.
<code>FS_NOR_BM_DisableECC()</code>	Disables the bit error correction via ECC.
<code>FS_NOR_BM_EnableCRC()</code>	Enables the data integrity check.
<code>FS_NOR_BM_EnableECC()</code>	Enables the bit error correction via ECC.
<code>FS_NOR_BM_SetBlankSectorSkip()</code>	Configures if the physical sectors which are already blank should be erased during the low-level format operation.
<code>FS_NOR_BM_SetByteOrderBE()</code>	Sets the byte order of multi byte management data to big-endian (default).
<code>FS_NOR_BM_SetByteOrderLE()</code>	Sets the byte order of multi-byte management data to little-endian format.
<code>FS_NOR_BM_SetCRCHook()</code>	Configures the calculation routines for CRC verification.
<code>FS_NOR_BM_SetECCHook()</code>	Configures the functions to be used for performing the bit error correction via ECC.
<code>FS_NOR_BM_SetDeviceLineSize()</code>	Configures the minimum number of bytes that can be written to NOR flash.
<code>FS_NOR_BM_SetDeviceRewriteSupport()</code>	Specifies if the NOR flash device can rewrite the same data if 0s are preserved.
<code>FS_NOR_BM_SetEraseVerification()</code>	Enables or disables the checking of the sector erase operation.
<code>FS_NOR_BM_SetFailSafeErase()</code>	Configures the fail-safe mode of the sector erase operation.
<code>FS_NOR_BM_SetInvalidSectorError()</code>	Configures if an error is reported when an invalid sector is read.
<code>FS_NOR_BM_SetMaxEraseCntDiff()</code>	Configure the threshold for the active wear leveling operation.
<code>FS_NOR_BM_SetNumWorkBlocks()</code>	Configures the number of work blocks.
<code>FS_NOR_BM_SetOnFatalErrorCallback()</code>	Registers a function to be called by the driver encounters a fatal error.
<code>FS_NOR_BM_SetPhyType()</code>	Configures the type of NOR physical layer.
<code>FS_NOR_BM_SetSectorSize()</code>	Configures the number of bytes in a logical sector.
<code>FS_NOR_BM_SetUsedSectorsErase()</code>	Configures if the physical sectors have to be erased at low-level format.
<code>FS_NOR_BM_SetWriteVerification()</code>	Enables or disables the checking of the page write operation.

6.4.3.2.1 FS_NOR_BM_Configure()

Description

Configures an instance of the Block Map NOR driver

Prototype

```
void FS_NOR_BM_Configure(U8 Unit,
                        U32 BaseAddr,
                        U32 StartAddr,
                        U32 NumBytes);
```

Parameters

Parameter	Description
Unit	Index of the Block Map NOR driver (0-based).
BaseAddr	Address of the first byte in NOR flash.
StartAddr	Address of the first byte the NOR driver is permitted to use as storage.
NumBytes	Number of bytes starting from StartAddr available to be used by the NOR driver as storage.

Additional information

This function is mandatory and it has to be called once in `FS_X_AddDevices()` for each instance of the Block Map NOR driver created by the application. Different instances of the NOR driver are identified by the `Unit` parameter.

`BaseAddr` is used only for NOR flash devices that are memory mapped. For serial NOR flash devices that are not memory mapped `BaseAddr` has to be set to 0.

`StartAddr` has to be greater than or equal to `BaseAddr` and smaller than the total number of bytes in the NOR flash device. The Block Map NOR driver rounds up `StartAddr` to the start address of the next physical sector in the NOR flash device.

`NumBytes` is rounded up to a physical sector boundary if the memory range defined by `StartAddr` and `NumBytes` is smaller than the capacity of the NOR flash device. If the memory range defined by `StartAddr` and `NumBytes` is larger than the capacity of the NOR flash device than `NumBytes` is rounded down so that the memory range fits into the NOR flash device.

The Block Map NOR driver can work only with physical sectors of the same size. The longest continuous range of physical sectors with the same size is chosen that fits in the range defined by `StartAddr` and `NumBytes` parameters.

Example

```
#include "FS.h"
#include "FS_NOR_HW_SPIFI_Template.h"

#define ALLOC_SIZE 0x4000 // Size defined in bytes

static U32 _aMemBlock[ALLOC_SIZE / 4]; // Memory pool used for
// semi-dynamic allocation.

/*****
 *
 * FS_X_AddDevices
 *
 * Function description
 * This function is called by the FS during FS_Init().
 */
void FS_X_AddDevices(void) {
    //
    // Give file system memory to work with.
```



```
//
FS_AssignMemory(&_aMemBlock[0], sizeof(_aMemBlock));
//
// Configure the size of the logical sector and activate the file buffering.
//
FS_SetMaxSectorSize(512);
FS_ConfigFileBufferDefault(512, FS_FILE_BUFFER_WRITE);
//
// Add and configure the NOR driver.
//
FS_AddDevice(&FS_NOR_BM_Driver);
FS_NOR_BM_SetPhyType(0, &FS_NOR_PHY_SPIFI);
FS_NOR_BM_Configure(0, 0x80000000, 0x80000000, 0x01000000);
FS_NOR_BM_SetSectorSize(0, 512);
//
// Configure the NOR physical layer.
//
FS_NOR_SPIFI_Allow2bitMode(0, 1);
FS_NOR_SPIFI_Allow4bitMode(0, 1);
FS_NOR_SPIFI_SetHWType(0, &FS_NOR_HW_SPIFI_Template);
}
```

6.4.3.2.2.2 FS_NOR_BM_DisableCRC()

Description

Disables the data integrity check.

Prototype

```
int FS_NOR_BM_DisableCRC(void);
```

Return value

= 0 Data integrity check deactivated.
≠ 0 An error occurred.

Additional information

The support for data integrity check is not available by default and it has to be included at compile time via the `FS_NOR_SUPPORT_CRC` define. This function disables the data integrity check for all instances of the NOR driver.

6.4.3.2.2.3 FS_NOR_BM_DisableECC()

Description

Disables the bit error correction via ECC.

Prototype

```
int FS_NOR_BM_DisableECC(U8 Unit);
```

Parameters

Parameter	Description
Unit	Index of the driver instance (0-based).

Return value

= 0 OK, ECC feature disabled.
≠ 0 An error occurred.

Additional information

This function is available only the file system sources are compiled with `FS_NOR_SUPPORT_ECC` set to 1.

6.4.3.2.2.4 FS_NOR_BM_EnableCRC()

Description

Enables the data integrity check.

Prototype

```
int FS_NOR_BM_EnableCRC(void);
```

Return value

= 0 Data integrity check activated.
≠ 0 An error occurred.

Additional information

The support for data integrity check is not available by default and it has to be included at compile time via the `FS_NOR_SUPPORT_CRC` define. This function enables the data integrity check for all instances of the NOR driver.

6.4.3.2.2.5 FS_NOR_BM_EnableECC()

Description

Enables the bit error correction via ECC.

Prototype

```
int FS_NOR_BM_EnableECC(U8 Unit);
```

Parameters

Parameter	Description
<code>Unit</code>	Index of the driver instance (0-based).

Return value

= 0 OK, ECC feature enabled.
≠ 0 An error occurred.

Additional information

This function is available only the file system sources are compiled with `FS_NOR_SUPPORT_ECC` set to 1.

6.4.3.2.2.6 FS_NOR_BM_SetBlankSectorSkip()

Description

Configures if the physical sectors which are already blank should be erased during the low-level format operation.

Prototype

```
void FS_NOR_BM_SetBlankSectorSkip(U8 Unit,
                                   U8 OnOff);
```

Parameters

Parameter	Description
<code>Unit</code>	Index of the Block Map NOR driver (0-based).
<code>OnOff</code>	Specifies if the feature has to be enabled or disabled <ul style="list-style-type: none"> • =0 All the physical sectors are erased. • ≠0 Physical sectors are not erased if they are blank (default).

Additional information

This function is optional. The blank checking feature is disabled by default and has to be explicitly enabled at compile time by setting `FS_NOR_SKIP_BLANK_SECTORS` to 1. The feature can then be enabled or disabled at runtime using `FS_NOR_BM_SetBlankSectorSkip()`.

Activating this feature can improve the speed of the low-level format operation when most of the physical sectors of the NOR flash device are already blank which is typically the case with NOR flash devices that ship from factory.

It is not recommended to enable this feature when performing a low-level format of a NOR flash device that was already used for data storage because the blank check operation is not able to determine if a physical sector was completely erased only by checking that all the bits are set to 1. An erase operation that is interrupted by an unexpected reset may leave the storage cells in an instable state even when the values of all storage cells in a physical sector read back as 1.

6.4.3.2.2.7 FS_NOR_BM_SetByteOrderBE()

Description

Sets the byte order of multi byte management data to big-endian (default).

Prototype

```
int FS_NOR_BM_SetByteOrderBE(void);
```

Return value

= 0 Multi-byte management data is stored in big-endian format.
≠ 0 An error occurred.

Additional information

This function is optional. Multi-byte management data is stored in the byte order of the CPU. Typically, `FS_NOR_BM_SetByteOrderBE()` is used by the NOR Image Creator utility to create NOR images with a byte order of the target CPU when the byte order of the host CPU is different. The byte order can be set to little-endian using `FS_NOR_BM_SetByteOrderLE()`. By default the byte order is set to little-endian.

The support for configurable byte order is disabled by default and has to be enabled by compiling the Block Map NOR driver with the `FS_NOR_SUPPORT_VARIABLE_BYTE_ORDER` configuration define set to 1 otherwise `FS_NOR_BM_SetByteOrderBE()` does nothing.

6.4.3.2.2.8 FS_NOR_BM_SetByteOrderLE()

Description

Sets the byte order of multi-byte management data to little-endian format.

Prototype

```
int FS_NOR_BM_SetByteOrderLE(void);
```

Return value

= 0 Multi-byte management data is stored in little-endian format.
≠ 0 An error occurred.

Additional information

This function is optional. Multi-byte management data is stored in the byte order of the CPU. Typically, `FS_NOR_BM_SetByteOrderLE()` is used by the NOR Image Creator utility to create NOR images with a byte order of the target CPU when the byte order of the host CPU is different. The byte order can be set to big-endian using `FS_NOR_BM_SetByteOrderBE()`. By default the byte order is set to little-endian.

The support for configurable byte order is disabled by default and has to be enabled by compiling the Block Map NOR driver with the `FS_NOR_SUPPORT_VARIABLE_BYTE_ORDER` configuration define set to 1 otherwise `FS_NOR_BM_SetByteOrderLE()` does nothing.

6.4.3.2.2.9 FS_NOR_BM_SetCRCHook()

Description

Configures the calculation routines for CRC verification.

Prototype

```
int FS_NOR_BM_SetCRCHook(const FS_NOR_CRC_HOOK * pCRCHook);
```

Parameters

Parameter	Description
pCRCHook	CRC calculation routines.

Return value

= 0 OK, CRC calculation routines set.
 ≠ 0 Error code indicating the failure reason.

Additional information

This function is optional. The driver uses by default the internal software routines of the file system for the CRC calculation. `FS_NOR_BM_SetCRCHook()` can be used by the application to specify different CRC calculation functions. This function is available only when the `FS_NOR_SUPPORT_CRC` configuration define is set to 1. In order to save ROM space, the internal CRC software routines can be disabled a runtime by setting the `FS_NOR_CRC_HOOK_DEFAULT` configuration define to NULL.

Example

```
#include "FS.h"
#include "FS_NOR_HW_SPI_Template.h"

#define ALLOC_SIZE 0x4000 // Size defined in bytes

static U32 _aMemBlock[ALLOC_SIZE / 4]; // Memory pool used for
// semi-dynamic allocation.

#if FS_NOR_SUPPORT_CRC

/*****
 *
 *     _CalcCRC8
 *
 * Function description
 *     Calculates an 8-bit CRC using a bit-by-bit algorithm.
 */
static U8 _CalcCRC8(const U8 * pData, unsigned NumBytes, U8 crc) {
    FS_USE_PARA(pData);
    FS_USE_PARA(NumBytes);
    FS_USE_PARA(crc);
    return 0; // TBD: Calculate the CRC.
}

/*****
 *
 *     _CalcCRC16
 *
 * Function description
 *     Calculates an 16-bit CRC using a bit-by-bit algorithm.
 */
static U16 _CalcCRC16(const U8 * pData, unsigned NumBytes, U16 crc) {
    FS_USE_PARA(pData);
    FS_USE_PARA(NumBytes);
    FS_USE_PARA(crc);
    return 0; // TBD: Calculate the CRC.
}

/*****
```

```

*
*     _CRCHook
*/
static const FS_NOR_CRC_HOOK _CRCHook = {
    _CalcCRC8,
    _CalcCRC16
};

#endif // FS_NOR_SUPPORT_CRC

/*****
*
*     FS_X_AddDevices
*
*     Function description
*     This function is called by the FS during FS_Init().
*/
void FS_X_AddDevices(void) {
    //
    // Give file system memory to work with.
    //
    FS_AssignMemory(&aMemBlock[0], sizeof(aMemBlock));
    //
    // Configure the size of the logical sector and activate the file buffering.
    //
    FS_SetMaxSectorSize(512);
#if FS_SUPPORT_FILE_BUFFER
    FS_ConfigFileBufferDefault(512, FS_FILE_BUFFER_WRITE);
#endif
    //
    // Add and configure the Block Map NOR driver.
    //
    FS_AddDevice(&FS_NOR_BM_Driver);
    FS_NOR_BM_SetPhyType(0, &FS_NOR_PHY_SFDP);
    FS_NOR_BM_Configure(0, 0, 0, 0x01000000);
    FS_NOR_BM_SetSectorSize(0, 512);
#if FS_NOR_SUPPORT_CRC
    FS_NOR_BM_EnableCRC();
    FS_NOR_BM_SetCRCHook(&_CRCHook);
#endif
    //
    // Configure the NOR physical layer.
    //
    FS_NOR_SFDP_SetHWType(0, &FS_NOR_HW_SPI_Template);
}

```

6.4.3.2.2.10 FS_NOR_BM_SetECCHook()

Description

Configures the functions to be used for performing the bit error correction via ECC.

Prototype

```
int FS_NOR_BM_SetECCHook(      U8          Unit,
                             const FS_NOR_ECC_HOOK * pECCHookMan,
                             const FS_NOR_ECC_HOOK * pECCHookData);
```

Parameters

Parameter	Description
Unit	Index of the driver instance (0-based).
pECCHookMan	Functions for the bit error correction of the management data.
pECCHookData	Functions for the bit error correction of the sector data.

Return value

= 0 OK, ECC functions registered.
 ≠ 0 An error occurred.

Additional information

This function is optional. The driver uses by default the internal software routines of the file system for the parity check calculation. `FS_NOR_BM_SetECCHook()` can be used by the application to specify different parity check calculation functions. This function is available only when the `FS_NOR_SUPPORT_ECC` configuration define is set to 1. In order to save ROM space, the internal CRC software routines can be disabled a runtime by setting the `FS_NOR_ECC_HOOK_MAN_DEFAULT` and `FS_NOR_ECC_HOOK_DATA_DEFAULT` configuration define to NULL.

6.4.3.2.2.11 FS_NOR_BM_SetDeviceLineSize()

Description

Configures the minimum number of bytes that can be written to NOR flash.

Prototype

```
int FS_NOR_BM_SetDeviceLineSize(U8 Unit,  
                                U8 ldBytesPerLine);
```

Parameters

Parameter	Description
<code>Unit</code>	Index of the Block Map NOR driver (0-based).
<code>ldBytesPerLine</code>	Line size in bytes as power of 2 exponent.

Return value

= 0 OK, line size changed.
≠ 0 Error code indicating the failure reason.

Additional information

This function is optional. Typically, the NOR flash have lines smaller than 4 bytes which is the fixed default value configured at compile time. The `FS_NOR_SUPPORT_VARIABLE_LINE_SIZE` configuration define has to be set to a value different than 0 in order to enable this function.

6.4.3.2.2.12 FS_NOR_BM_SetDeviceRewriteSupport()

Description

Specifies if the NOR flash device can rewrite the same data if 0s are preserved.

Prototype

```
int FS_NOR_BM_SetDeviceRewriteSupport(U8 Unit,
                                       U8 OnOff);
```

Parameters

Parameter	Description
Unit	Index of the Block Map NOR driver (0-based).
OnOff	Enables / disables the support for rewrite. <ul style="list-style-type: none"> • =0 Rewrite support is disabled. • ≠0 Rewrite support is enabled.

Return value

= 0 OK, support for rewrite changed.
 ≠ 0 Error code indicating the failure reason.

Additional information

This function is optional. Typically, the NOR flash devices are able to rewrite the same data and by default this feature is disabled at compile time. The `FS_NOR_SUPPORT_VARIABLE_LINE_SIZE` configuration define has to be set to a value different than 0 in order to enable this function, otherwise the function does nothing.

6.4.3.2.2.13 FS_NOR_BM_SetEraseVerification()

Description

Enables or disables the checking of the sector erase operation.

Prototype

```
void FS_NOR_BM_SetEraseVerification(U8 Unit,
                                     U8 OnOff);
```

Parameters

Parameter	Description
Unit	Index of the Block Map NOR driver (0-based).
OnOff	Specifies if the feature has to be enabled or disabled <ul style="list-style-type: none"> • =0 The erase operation is not checked. • ≠0 The erase operation is checked.

Additional information

This function is optional. The result of a sector erase operation is normally checked by evaluating the error bits maintained by the NOR flash device in a internal status register. `FS_NOR_BM_SetEraseVerification()` can be used to enable additional verification of the sector erase operation that is realized by reading back the contents of the entire erased physical sector and by checking that all the bytes in it are set to `0xFF`. Enabling this feature can negatively impact the write performance of Block Map NOR driver.

The sector erase verification feature is active only when the Block Map NOR driver is compiled with the `FS_NOR_VERIFY_ERASE` configuration define is set to 1 (default is 0) or when the `FS_DEBUG_LEVEL` configuration define is set to a value greater than or equal to `FS_DEBUG_LEVEL_CHECK_ALL`.

6.4.3.2.2.14 FS_NOR_BM_SetFailSafeErase()

Description

Configures the fail-safe mode of the sector erase operation.

Prototype

```
int FS_NOR_BM_SetFailSafeErase(U8 Unit,
                               U8 OnOff);
```

Parameters

Parameter	Description
<code>Unit</code>	Index of the Block Map NOR driver (0-based).
<code>OnOff</code>	Specifies if the feature has to be enabled or disabled <ul style="list-style-type: none"> • =0 Sector erase operation is not fail-safe. • ≠0 Sector erase operation is fail-safe.

Return value

= 0 OK, fail safe mode configured.
 ≠ 0 Error code indicating the failure reason.

Additional information

This function is optional. It can be used by the application to enable or disable the fail-safe sector erase feature of the Block Map NOR driver. The fail-safe sector erase feature helps the driver identify a sector erase operation that did not completed successfully due to an unexpected power failure. The Block Map NOR driver enables the fail-safe sector erase feature by default except when the NOR flash device does not support modifying the same data more than once (rewrite) or when the application activates the data integrity check feature via CRC. This is done for backward compatibility reasons. The application has to use `FS_NOR_BM_SetFailSafeErase()` to explicitly enable the fail-safe sector erase feature for configurations that require a fail-safe operation.

In addition, enabling the fail-safe sector erase feature has the potential of improving the performance of the clean operation executed via `FS_STORAGE_Clean()` and `FS_STORAGE_CleanOne()`.

The value configured via `FS_NOR_BM_SetFailSafeErase()` is evaluated only during the low-level format operation. That is, after changing the activation status of the fail-safe sector erase feature a low-level format operation has to be performed via `FS_FormatLow()` in order for the new configuration to be applied.

6.4.3.2.2.15 FS_NOR_BM_SetInvalidSectorError()

Description

Configures if an error is reported when an invalid sector is read.

Prototype

```
void FS_NOR_BM_SetInvalidSectorError(U8 Unit,
                                     U8 OnOff);
```

Parameters

Parameter	Description
<code>Unit</code>	Index of the Block Map NOR driver (0-based).
<code>OnOff</code>	Specifies if the feature has to be enabled or disabled <ul style="list-style-type: none"> • =0 No error is reported. • ≠0 An error is reported.

Additional information

This function is optional. An invalid sector is a logical sector that does not store any data. All logical sectors are invalid after a low-level format operation. A logical sector becomes valid as soon as the file system writes some data to it. The file system does not read invalid sectors with the exception of a high-level format operation.

By default the Block Map NOR driver does not report any error when the file system reads an invalid sector. The contents of an invalid sector is filled with the byte pattern specified via `FS_NOR_READ_BUFFER_FILL_PATTERN`.

6.4.3.2.2.16 FS_NOR_BM_SetMaxEraseCntDiff()

Description

Configure the threshold for the active wear leveling operation.

Prototype

```
void FS_NOR_BM_SetMaxEraseCntDiff(U8 Unit,  
                                   U32 EraseCntDiff);
```

Parameters

Parameter	Description
<code>Unit</code>	Index of the Block Map NOR driver (0-based).
<code>EraseCntDiff</code>	Difference between the erase counts.

Additional information

This function is optional. The application can use `FS_NOR_BM_SetMaxEraseCntDiff()` to modify the value of the threshold that is used to decide if a data block has to be relocated to make sure that is equally erased. The Block Map NOR driver compares the difference between the erase counts of two blocks with the configured value. If the calculated difference is larger than `EraseCntDiff` then the block with the smaller erase count is copied to the block with the larger erase count then the block with the smaller erase count is used to store new data to it.

6.4.3.2.2.17 FS_NOR_BM_SetNumWorkBlocks()

Description

Configures the number of work blocks.

Prototype

```
void FS_NOR_BM_SetNumWorkBlocks(U8      Unit,
                                unsigned NumWorkBlocks);
```

Parameters

Parameter	Description
<code>Unit</code>	Index of the Block Map NOR driver (0-based).
<code>NumWorkBlocks</code>	Number of work blocks to configure.

Additional information

This function is optional. Work blocks are physical sectors that are used by the Block Map NOR driver to temporarily store the data written to NOR flash device by the file system layer. An application can use this function to modify the number of work blocks used by the Block Map NOR driver according to its requirements. By default, the Block Map NOR driver allocates 1% from the total number of physical sectors configured for storage but no more than 10 work blocks. The minimum number of work blocks allocated by default depends on whether journaling is activated or not in the application. If the journal is active the 4 work blocks are allocated otherwise 3.

The write performance of the Block Map NOR driver can be improved by increasing the number work blocks which at the same time increases the RAM usage.

The NOR flash device has to be reformatted in order for the new number of work blocks to take effect.

6.4.3.2.2.18 FS_NOR_BM_SetOnFatalErrorCallback()

Description

Registers a function to be called by the driver encounters a fatal error.

Prototype

```
void FS_NOR_BM_SetOnFatalErrorCallback  
    (FS_NOR_ON_FATAL_ERROR_CALLBACK * pOnFatalError);
```

Parameters

Parameter	Description
pOnFatalError	Address to the callback function.

Additional information

Typically, the NOR driver reports a fatal error when data integrity check (CRC) fails.

All instances of the NOR driver share the same callback function. The Unit member of the `FS_NOR_FATAL_ERROR_INFO` structure passed as parameter to the [pOnFatalError](#) callback function indicates which driver instance triggered the fatal error.

6.4.3.2.2.19 FS_NOR_BM_SetPhyType()

Description

Configures the type of NOR physical layer.

Prototype

```
void FS_NOR_BM_SetPhyType(      U8          Unit,
                               const FS_NOR_PHY_TYPE * pPhyType);
```

Parameters

Parameter	Description
<code>Unit</code>	Index of the Block Map NOR driver (0-based).
<code>pPhyType</code>	in NOR physical layer.

Additional information

This function is mandatory and it has to be called once in `FS_X_AddDevices()` for each instance of the Block Map NOR driver created by the application. Different instances of the Block Map NOR driver are identified by the `Unit` parameter.

Permitted values for the `pPhyType` parameter are:

Identifier	Description
<code>FS_NOR_PHY_CFI_1x16</code>	One CFI compliant NOR flash device with 16-bit interface.
<code>FS_NOR_PHY_CFI_2x16</code>	Two CFI compliant NOR flash device with 16-bit interfaces.
<code>FS_NOR_PHY_DSPI</code>	This a pseudo physical layer that uses the physical layers <code>FS_NOR_PHY_ST_M25</code> and <code>FS_NOR_PHY_SFDP</code>
<code>FS_NOR_PHY_SFDP</code>	Serial NOR flash devices that support Serial Flash Discoverable Parameters (SFDP)
<code>FS_NOR_PHY_SPIFI</code>	Memory mapped serial quad NOR flash devices.
<code>FS_NOR_PHY_ST_M25</code>	Serial NOR flash devices compatible to ST ST25Pxx.

6.4.3.2.20 FS_NOR_BM_SetSectorSize()

Description

Configures the number of bytes in a logical sector.

Prototype

```
void FS_NOR_BM_SetSectorSize(U8 Unit,  
                             unsigned SectorSize);
```

Parameters

Parameter	Description
<code>Unit</code>	Index of the Block Map NOR driver (0-based).
<code>SectorSize</code>	Number of bytes in a logical sector.

Additional information

This function is optional. It can be used to modify the size of the logical sector used by the Block Map NOR driver. By default the Block Map NOR driver uses the logical sector size configured a file system level that is set to 512 bytes at the file system initialization and can be later changed via `FS_SetMaxSectorSize()`. The NOR flash device has to be reformatted in order for the new logical sector size to take effect.

`SectorSize` has to be a power of 2 value.

6.4.3.2.2.1 FS_NOR_BM_SetUsedSectorsErase()

Description

Configures if the physical sectors have to be erased at low-level format.

Prototype

```
void FS_NOR_BM_SetUsedSectorsErase(U8 Unit,  
                                     U8 OnOff);
```

Parameters

Parameter	Description
Unit	Index of the Block Map NOR driver (0-based).
OnOff	Specifies if the feature has to be enabled or disabled <ul style="list-style-type: none">• =0 Physical sectors are invalidated (default).• ≠0 Physical sectors are erased.

Additional information

This function is optional. The default behavior of the Block Map NOR driver is to invalidate the physical sectors at low-level format which makes the format operation faster.

6.4.3.2.22 FS_NOR_BM_SetWriteVerification()

Description

Enables or disables the checking of the page write operation.

Prototype

```
void FS_NOR_BM_SetWriteVerification(U8 Unit,
                                   U8 OnOff);
```

Parameters

Parameter	Description
<code>Unit</code>	Index of the Block Map NOR driver (0-based).
<code>OnOff</code>	Specifies if the feature has to be enabled or disabled <ul style="list-style-type: none"> • =0 The write operation is not checked. • ≠0 The write operation is checked.

Additional information

This function is optional. The result of a page write operation is normally checked by evaluating the error bits maintained by the NOR flash device in a internal status register. `FS_NOR_BM_SetWriteVerification()` can be used to enable additional verification of the page write operation. This is done by reading back the contents of the written page and by checking that all the bytes are matching the data requested to be written. Enabling this feature can negatively impact the write performance of Block Map NOR driver.

The page write verification feature is active only when the Block Map NOR driver is compiled with the `FS_NOR_VERIFY_WRITE` configuration define is set to 1 (default is 0) or when the `FS_DEBUG_LEVEL` configuration define is set to a value greater than or equal to `FS_DEBUG_LEVEL_CHECK_ALL`.

6.4.3.2.2.23 FS_NOR_CRC_HOOK

Description

Callback functions for the CRC calculation.

Type definition

```
typedef struct {  
    FS_NOR_CRC_HOOK_CALC_CRC8 * pfCalcCRC8;  
    FS_NOR_CRC_HOOK_CALC_CRC16 * pfCalcCRC16;  
} FS_NOR_CRC_HOOK;
```

Structure members

Member	Description
pfCalcCRC8	Calculates an 8-bit CRC.
pfCalcCRC16	Calculates a 16-bit CRC.

Additional information

By default the Block Map NOR driver uses internal functions of the file system for the CRC calculation. This structure can be used to configure external CRC calculation callback functions that for example use hardware CRC calculation units for increased performance. The application can register the calculation callback functions via `FS_NOR_BM_SetCRCHook()`

6.4.3.2.2.24 FS_NOR_CRC_HOOK_CALC_CRC8

Description

The type of the callback function invoked by the NOR driver to calculate an 8-bit CRC.

Type definition

```
typedef U8 FS_NOR_CRC_HOOK_CALC_CRC8(const U8      * pData,
                                     unsigned NumBytes,
                                     U8        crc);
```

Parameters

Parameter	Description
<code>pData</code>	in Data to be protected by CRC.
<code>NumBytes</code>	Number of bytes to be protected by CRC.
<code>crc</code>	Initial CRC value.

Return value

Calculated 8-bit CRC.

Additional information

This function calculates the CRC of the `NumBytes` of data pointed to by `pData`. The type of polynomial is not relevant.

6.4.3.2.2.25 FS_NOR_CRC_HOOK_CALC_CRC16

Description

The type of the callback function invoked by the NOR driver to calculate a 16-bit CRC.

Type definition

```
typedef U16 FS_NOR_CRC_HOOK_CALC_CRC16(const U8      * pData,
                                         unsigned NumBytes,
                                         U16      crc);
```

Parameters

Parameter	Description
<code>pData</code>	in Data to be protected by CRC.
<code>NumBytes</code>	Number of bytes to be protected by CRC.
<code>crc</code>	Initial CRC value.

Return value

Calculated 16-bit CRC.

Additional information

This function calculates the CRC of the `NumBytes` of data pointed to by `pData`. The type of polynomial is not relevant. `NumBytes` is always an even number. `pData` is always aligned to a 16-bit boundary.

6.4.3.2.26 FS_NOR_ECC_HOOK

Description

Callback functions for the ECC calculation.

Type definition

```
typedef struct {
    FS_NOR_ECC_HOOK_CALC * pfCalc;
    FS_NOR_ECC_HOOK_APPLY * pfApply;
    U8 NumBitsCorrectable;
    U8 ldBytesPerBlock;
} FS_NOR_ECC_HOOK;
```

Structure members

Member	Description
pfCalc	Calculates the ECC of the specified data.
pfApply	Verifies and corrects bit errors using ECC.
NumBitsCorrectable	Number of bits the ECC algorithm is able to correct in the data block and 4 bytes of spare area.
ldBytesPerBlock	Number of bytes in the data block given as power of 2 value.

Additional information

By default the Block Map NOR driver uses internal functions of the file system for the ECC calculation. This structure can be used to configure external ECC calculation callback functions that for example use hardware ECC calculation units for increased performance. The application can register the calculation callback functions via `FS_NOR_BM_SetECCHook()`

6.4.3.2.2.27 FS_NOR_ECC_HOOK_CALC

Description

Callback function that calculates the ECC of a data block.

Type definition

```
typedef void FS_NOR_ECC_HOOK_CALC(const U32 * pData,  
                                  U8   * pECC);
```

Parameters

Parameter	Description
<code>pData</code>	<code>in</code> Data to be protected by ECC.
<code>pECC</code>	<code>out</code> Calculated parity check.

Additional information

The number of bytes in `pData` is specified by `FS_NOR_ECC_HOOK::IdBytesPerBlock`

6.4.3.2.2.28 FS_NOR_ECC_HOOK_APPLY

Description

Callback function that corrects bit errors in a data block using ECC.

Type definition

```
typedef int FS_NOR_ECC_HOOK_APPLY(U32 * pData,
                                   U8  * pECC);
```

Parameters

Parameter	Description
<code>pData</code>	<code>in</code> Data to be checked for bit errors using ECC. <code>out</code> Data without bit errors.
<code>pECC</code>	<code>in</code> Parity check read from storage. <code>out</code> Parity check without bit errors.

Return value

- ≥ 0 OK, number of bit errors corrected.
- < 0 Error, an uncorrectable bit error occurred.

Additional information

The number of bytes in `pData` is specified by `FS_NOR_ECC_HOOK::IdBytesPerBlock`

6.4.3.2.29 FS_NOR_FATAL_ERROR_INFO

Description

Information passed to callback function when a fatal error occurs.

Type definition

```
typedef struct {  
    U8    Unit;  
    U8    ErrorType;  
    U32   ErrorPSI;  
} FS_NOR_FATAL_ERROR_INFO;
```

Structure members

Member	Description
Unit	Index of the driver that triggered the fatal error.
ErrorType	Type of the error that occurred.
ErrorPSI	Index of the physical sector in which the error occurred.

6.4.3.2.2.30 FS_NOR_ON_FATAL_ERROR_CALLBACK

Description

The type of the callback function invoked by the NOR driver when a fatal error occurs.

Type definition

```
typedef int FS_NOR_ON_FATAL_ERROR_CALLBACK(FS_NOR_FATAL_ERROR_INFO * pFatalErrorInfo);
```

Parameters

Parameter	Description
<code>pFatalErrorInfo</code>	Information about the fatal error.

Return value

- = 0 The NOR driver has to mark the NOR flash device as read only.
- ≠ 0 The NOR flash device has to remain writable.

Additional information

If the callback function returns a 0 the NOR driver marks the NOR flash device as read-only and it remains in this state until the NOR flash device is low-level formatted. In this state, all further write operations are rejected with an error by the NOR driver.

The application is responsible to handle the fatal error by for example checking the consistency of the file system via `FS_CheckDisk()`. The callback function is not allowed to invoke any other FS API functions therefore the handling of the error has to be done after the FS API function that triggered the error returns.

6.4.3.3 Additional driver functions

The functions documented in this section are optional. They can be used to get information about the Block Map NOR driver or to directly access the data stored on the NOR flash device.

Function	Description
<code>FS_NOR_BM_EraseDevice()</code>	Erases all the physical sectors configured as storage.
<code>FS_NOR_BM_ErasePhySector()</code>	Sets all the bits in a physical sector to 1.
<code>FS_NOR_BM_FormatLow()</code>	Performs a low-level format of NOR flash device.
<code>FS_NOR_BM_GetDiskInfo()</code>	Returns information about the organization and the management of the NOR flash device.
<code>FS_NOR_BM_GetSectorInfo()</code>	Returns information about a specified physical sector.
<code>FS_NOR_BM_GetStatCounters()</code>	Returns the values of the statistical counters.
<code>FS_NOR_BM_IsCRCEnabled()</code>	Checks if the data integrity checking is enabled.
<code>FS_NOR_BM_IsECCEnabled()</code>	Checks if the bit error correction via ECC is enabled or not.
<code>FS_NOR_BM_IsLLFormatted()</code>	Checks if the NOR flash is low-level formatted.
<code>FS_NOR_BM_Mount()</code>	Mounts the NOR flash device.
<code>FS_NOR_BM_ReadOff()</code>	Reads a range of bytes from the NOR flash device.
<code>FS_NOR_BM_ResetStatCounters()</code>	Sets the value of the statistical counters to 0.
<code>FS_NOR_BM_SuspendWearLeveling()</code>	Disables temporarily the wear leveling process.
<code>FS_NOR_BM_WriteOff()</code>	Writes data to NOR flash memory.

6.4.3.3.1 FS_NOR_BM_EraseDevice()

Description

Erases all the physical sectors configured as storage.

Prototype

```
int FS_NOR_BM_EraseDevice(U8 Unit);
```

Parameters

Parameter	Description
Unit	Index of the Block Map NOR driver (0-based).

Return value

= 0 Physical sectors erased.
≠ 0 An error occurred.

Additional information

This function is optional. After the call to this function all the bytes in area of the NOR flash device configured as storage are set to 0xFF.

6.4.3.3.2 FS_NOR_BM_ErasePhySector()

Description

Sets all the bits in a physical sector to 1.

Prototype

```
int FS_NOR_BM_ErasePhySector(U8 Unit,  
                             U32 PhySectorIndex);
```

Parameters

Parameter	Description
Unit	Index of the Block Map NOR driver (0-based).
PhySectorIndex	Index of the physical sector to be erased.

Return value

= 0 OK, physical sector erased successfully.
≠ 0 An error occurred.

Additional information

[PhySectorIndex](#) is 0-based and is relative to the beginning of the NOR flash area configured via [FS_NOR_BM_Configure\(\)](#). The number of bytes actually erased depends on the size of the physical sector supported by the NOR flash device. Information about a physical sector can be obtained via [FS_NOR_BM_GetSectorInfo\(\)](#).

6.4.3.3 FS_NOR_BM_FormatLow()

Description

Performs a low-level format of NOR flash device.

Prototype

```
int FS_NOR_BM_FormatLow(U8 Unit);
```

Parameters

Parameter	Description
Unit	Index of the Block Map NOR driver (0-based).

Return value

= 0 OK, NOR flash device has been successfully low-level formatted.
≠ 0 An error occurred.

Additional information

This function is optional. `FS_NOR_BM_FormatLow()` erases the first physical sector and stores the format information in it. The other physical sectors are either erased or invalidated. Per default the physical sectors are invalidated in order to reduce the time it takes for the operation to complete. The application can request the Block Map NOR driver to erase the physical sectors instead of invalidating them by calling `FS_NOR_BM_SetUsedSectorsErase()` with the `Off` parameter set to 1.

6.4.3.3.4 FS_NOR_BM_GetDiskInfo()

Description

Returns information about the organization and the management of the NOR flash device.

Prototype

```
int FS_NOR_BM_GetDiskInfo(U8 Unit,
                          FS_NOR_BM_DISK_INFO * pDiskInfo);
```

Parameters

Parameter	Description
Unit	Index of the Block Map NOR driver (0-based).
pDiskInfo	out Requested information.

Return value

= 0 OK, information returned.
 ≠ 0 An error occurred.

Additional information

This function is not required for the functionality of the Block Map NOR driver and will typically not be linked in production builds.

Example

```
#include "FS.h"

void SampleNOR_BMGetDiskInfo(void) {
    int r;
    char ac[128];
    FS_NOR_BM_DISK_INFO DiskInfo;

    FS_X_Log("Get information about the first Block Map NOR driver instance\n");
    r = FS_NOR_BM_GetDiskInfo(0, &DiskInfo);
    if (r == 0) {
        SEGGER_sprintf(ac, sizeof(ac),
            " Physical sectors: %lu\n", DiskInfo.NumPhySectors);
        FS_X_Log(ac);
        SEGGER_sprintf(ac, sizeof(ac),
            " Logical blocks: %lu\n", DiskInfo.NumLogBlocks);
        FS_X_Log(ac);
        SEGGER_sprintf(ac, sizeof(ac),
            " Used physical sectors: %lu\n", DiskInfo.NumUsedPhySectors);
        FS_X_Log(ac);
        SEGGER_sprintf(ac, sizeof(ac),
            " Valid physical sectors: %lu\n", DiskInfo.NumPhySectorsValid);
        FS_X_Log(ac);
        SEGGER_sprintf(ac, sizeof(ac),
            " Logical sectors in a physical sector: %lu\n", DiskInfo.LSectorsPerPSector);
        FS_X_Log(ac);
        SEGGER_sprintf(ac, sizeof(ac),
            " Logical sector size: %lu bytes\n", DiskInfo.BytesPerSector);
        FS_X_Log(ac);
        SEGGER_sprintf(ac, sizeof(ac),
            " Minimum erase count: %lu\n", DiskInfo.EraseCntMin);
        FS_X_Log(ac);
        SEGGER_sprintf(ac, sizeof(ac),
            " Maximum erase count: %lu\n", DiskInfo.EraseCntMax);
        FS_X_Log(ac);
        SEGGER_sprintf(ac, sizeof(ac),
            " Average erase count: %lu\n", DiskInfo.EraseCntAvg);
        FS_X_Log(ac);
        SEGGER_sprintf(ac, sizeof(ac),
            " Erase counts for average: %lu\n", DiskInfo.NumEraseCnt);
        FS_X_Log(ac);
        SEGGER_sprintf(ac, sizeof(ac),
```

```
    " Fatal error:                                %s
\n", DiskInfo.HasFatalError ? "yes" : "no");
    FS_X_Log(ac);
    SEGGER_sprintf(ac, sizeof(ac),
    " Fatal error type:                            %d\n", DiskInfo.ErrorType);
    FS_X_Log(ac);
    SEGGER_sprintf(ac, sizeof(ac),
    " Fatal error location (PSI):                 %lu\n", DiskInfo.ErrorPSI);
    FS_X_Log(ac);
    SEGGER_sprintf(ac, sizeof(ac),
    " Write protected:                            %s
\n", DiskInfo.IsWriteProtected ? "yes": "no");
    FS_X_Log(ac);
    SEGGER_sprintf(ac, sizeof(ac),
    " Suspended wear leveling:                   %s
\n", DiskInfo.IsWLSuspended ? "yes" : "no");
    FS_X_Log(ac);
    SEGGER_sprintf(ac, sizeof(ac),
    " Maximum erase count difference:            %lu\n", DiskInfo.MaxEraseCntDiff);
    FS_X_Log(ac);
    SEGGER_sprintf(ac, sizeof(ac),
    " Work blocks:                                %lu\n", DiskInfo.NumWorkBlocks);
    FS_X_Log(ac);
}
}
```

6.4.3.3.5 FS_NOR_BM_GetSectorInfo()

Description

Returns information about a specified physical sector.

Prototype

```
int FS_NOR_BM_GetSectorInfo(U8          Unit,
                           U32          PhySectorIndex,
                           FS_NOR_BM_SECTOR_INFO * pSectorInfo);
```

Parameters

Parameter	Description
Unit	Index of the Block Map NOR driver (0-based).
PhySectorIndex	Index of the physical sector to be queried (0-based).
pSectorInfo	out Information related to the specified physical sector.

Return value

= 0 OK, information returned.
 ≠ 0 An error occurred.

Additional information

This function is optional. The application can use it to get information about the usage of a particular physical sector.

[PhySectorIndex](#) is relative to the beginning of the region configured as storage via [FS_NOR_BM_Configure\(\)](#).

Example

```
#include <stdio.h>
#include "FS.h"

void SampleNOR_BMGetDiskInfo(void) {
    int            r;
    char           ac[128];
    const char    * sType;
    FS_NOR_BM_SECTOR_INFO SectorInfo;

    FS_X_Log("Get information about the physical sector 0 of the first Block Map NOR driver instance\n");
    r = FS_NOR_BM_GetSectorInfo(0, 0, &SectorInfo);
    if (r == 0) {
        switch (SectorInfo.Type) {
            case FS_NOR_BLOCK_TYPE_DATA:
                sType = "DATA";
                break;
            case FS_NOR_BLOCK_TYPE_WORK:
                sType = "WORK";
                break;
            case FS_NOR_BLOCK_TYPE_EMPTY_ERASED:
                sType = "EMPTY";
                break;
            case FS_NOR_BLOCK_TYPE_EMPTY_NOT_ERASED:
                sType = "INVALID";
                break;
            case FS_NOR_BLOCK_TYPE_UNKNOWN:
                // through
            default:
                sType = "UNKNOWN";
                break;
        }
        SEGGER_sprintf(ac, sizeof(ac), " Offset:           %d\n", SectorInfo.Off);
        FS_X_Log(ac);
        SEGGER_sprintf(ac, sizeof(ac), " Size:           %d bytes\n", SectorInfo.Size);
```

```
FS_X_Log(ac);
SEGGER_sprintf(ac, sizeof(ac), " Erase count:      %d\n", SectorInfo.EraseCnt);
FS_X_Log(ac);
SEGGER_sprintf(ac, sizeof(ac), " Logical block index: %d\n", SectorInfo.lbi);
FS_X_Log(ac);
SEGGER_sprintf(ac, sizeof(ac), " Block type:      %s\n", sType);
FS_X_Log(ac);
}
```

6.4.3.3.6 FS_NOR_BM_GetStatCounters()

Description

Returns the values of the statistical counters.

Prototype

```
void FS_NOR_BM_GetStatCounters(U8 Unit,
                               FS_NOR_BM_STAT_COUNTERS * pStat);
```

Parameters

Parameter	Description
Unit	Index of the Block Map NOR driver (0-based).
pStat	out Statistical counter values.

Additional information

This function is optional. The application can use it to get the actual values of the statistical counters maintained by the Block Map NOR driver. The statistical counters provide information about the number of internal operations performed by the Block Map NOR driver such as sector read and write. All statistical counters are set to 0 when the NOR flash device is low-level mounted. The application can explicitly set them to 0 by using `FS_NOR_BM_ResetStatCounters()`. A separate set of statistical counters is maintained for each instance of the Block Map NOR driver.

The statistical counters are available only when the block map NOR driver is compiled with the `FS_DEBUG_LEVEL` configuration define set to a value greater than or equal to `FS_DEBUG_LEVEL_CHECK_ALL` or with the `FS_NOR_ENABLE_STATS` configuration define set to 1.

Example

```
#include "FS.h"

void SampleNOR_BMGetStatCounters(void) {
#if FS_NOR_ENABLE_STATS
    char          ac[128];
    int           i;
    FS_NOR_BM_STAT_COUNTERS Stat;

    FS_X_Log("Get statistical counters of the first Block Map NOR driver instance\n");
    FS_NOR_BM_GetStatCounters(0, &Stat);
    SEGGER_sprintf(ac, sizeof(ac),
        " Free logical blocks:           %lu\n", Stat.NumFreeBlocks);
    FS_X_Log(ac);
    SEGGER_sprintf(ac, sizeof(ac),
        " Physical sectors erased:       %lu\n", Stat.EraseCnt);
    FS_X_Log(ac);
    SEGGER_sprintf(ac, sizeof(ac),
        " Logical sectors read:           %lu\n", Stat.ReadSectorCnt);
    FS_X_Log(ac);
    SEGGER_sprintf(ac, sizeof(ac),
        " Logical sectors written:        %lu\n", Stat.WriteSectorCnt);
    FS_X_Log(ac);
    SEGGER_sprintf(ac, sizeof(ac),
        " Blocks converted via copy:       %lu\n", Stat.ConvertViaCopyCnt);
    FS_X_Log(ac);
    SEGGER_sprintf(ac, sizeof(ac),
        " Blocks converted in-place:      %lu\n", Stat.ConvertInPlaceCnt);
    FS_X_Log(ac);
    SEGGER_sprintf(ac, sizeof(ac),
        " Valid logical sectors:          %lu\n", Stat.NumValidSectors);
    FS_X_Log(ac);
    SEGGER_sprintf(ac, sizeof(ac),
        " Logical sectors copied:         %lu\n", Stat.CopySectorCnt);
    FS_X_Log(ac);
    SEGGER_sprintf(ac, sizeof(ac),
        " Read retries:                   %lu\n", Stat.NumReadRetries);
```



```

FS_X_Log(ac);
SEGGER_sprintf(ac, sizeof(ac),
    " Physical sector headers read:    %lu\n", Stat.ReadPSHCnt);
FS_X_Log(ac);
SEGGER_sprintf(ac, sizeof(ac),
    " Physical sector headers written: %lu\n", Stat.WritePSHCnt);
FS_X_Log(ac);
SEGGER_sprintf(ac, sizeof(ac),
    " Logical sector headers read:    %lu\n", Stat.ReadLSHCnt);
FS_X_Log(ac);
SEGGER_sprintf(ac, sizeof(ac),
    " Logical sector headers written: %lu\n", Stat.WriteLSHCnt);
FS_X_Log(ac);
SEGGER_sprintf(ac, sizeof(ac),
    " Read operations:                %lu\n", Stat.ReadCnt);
FS_X_Log(ac);
SEGGER_sprintf(ac, sizeof(ac),
    " Bytes read:                    %lu\n", Stat.ReadByteCnt);
FS_X_Log(ac);
SEGGER_sprintf(ac, sizeof(ac),
    " Write operations:              %lu\n", Stat.WriteCnt);
FS_X_Log(ac);
SEGGER_sprintf(ac, sizeof(ac),
    " Bytes written:                 %lu\n", Stat.WriteByteCnt);
FS_X_Log(ac);
SEGGER_sprintf(ac, sizeof(ac),
    " Total bit errors corrected:    %lu\n", Stat.BitErrorCnt);
FS_X_Log(ac);
for (i = 0; i < FS_NOR_STAT_MAX_BIT_ERRORS; ++i) {
    SEGGER_sprintf(ac, sizeof(ac),
        " %d-bit errors corrected:    %lu\n", i + 1, Stat.aBitErrorCnt[i]);
}
#endif
}

```

6.4.3.3.7 FS_NOR_BM_IsCRCEnabled()

Description

Checks if the data integrity checking is enabled.

Prototype

```
int FS_NOR_BM_IsCRCEnabled(void);
```

Return value

= 0 Data integrity check is deactivated.
≠ 0 Data integrity check is activated.

Additional information

This function is available only the file system sources are compiled with `FS_NOR_SUPPORT_CRC` set to 1.

6.4.3.3.8 FS_NOR_BM_IsECCEnabled()

Description

Checks if the bit error correction via ECC is enabled or not.

Prototype

```
int FS_NOR_BM_IsECCEnabled(U8 Unit);
```

Parameters

Parameter	Description
<code>Unit</code>	Index of the driver instance (0-based).

Return value

≠ 0 The ECC feature is enabled.
= 0 The ECC feature is disabled.

Additional information

This function is available only the file system sources are compiled with `FS_NOR_SUPPORT_ECC` set to 1.

6.4.3.3.9 FS_NOR_BM_IsLLFormatted()

Description

Checks if the NOR flash is low-level formatted.

Prototype

```
int FS_NOR_BM_IsLLFormatted(U8 Unit);
```

Parameters

Parameter	Description
<code>Unit</code>	Index of the Block Map NOR driver (0-based).

Return value

- $\neq 0$ The NOR flash device is low-level formatted.
- $= 0$ The NOR flash device is not low-level formatted or an error has occurred.

Additional information

This function is optional. An application should use `FS_IsLLFormatted()` instead.

6.4.3.3.10 FS_NOR_BM_Mount()

Description

Mounts the NOR flash device.

Prototype

```
int FS_NOR_BM_Mount(U8 Unit,
                    FS_NOR_BM_MOUNT_INFO * pMountInfo);
```

Parameters

Parameter	Description
<code>Unit</code>	Index of the driver instance (0-based).
<code>pMountInfo</code>	<code>out</code> Information about the mounted NOR flash device. Can be set to <code>NULL</code> .

Return value

= 0 OK, NOR flash device successfully mounted.
 ≠ 0 Error, could not mount NOR flash device.

Additional information

`FS_NOR_BM_Mount()` can be used to explicitly mount the NOR flash device and to get information about it. This function returns a subset of the information returned by `FS_NOR_BM_GetDiskInfo()` and therefore can be used instead of it if the application does not require statistical information about the usage of the NOR sectors. Typically, `FS_NOR_BM_Mount()` requires less time to complete than `FS_NOR_BM_GetDiskInfo()`.

This function is not required for the functionality of the Block Map driver and is typically not linked in production builds.

6.4.3.3.11 FS_NOR_BM_ReadOff()

Description

Reads a range of bytes from the NOR flash device.

Prototype

```
int FS_NOR_BM_ReadOff(U8      Unit,  
                     void * pData,  
                     U32      Off,  
                     U32      NumBytes);
```

Parameters

Parameter	Description
<code>Unit</code>	Index of the Block Map NOR driver (0-based).
<code>pData</code>	<code>out</code> Read data.
<code>Off</code>	Offset of the first byte to be read.
<code>NumBytes</code>	Number of bytes to be read.

Return value

= 0 OK, data read.
≠ 0 An error occurred.

Additional information

This function is not required for the functionality of the driver and will typically not be linked in production builds.

`Off` has to be specified in bytes and is relative to the beginning of the NOR flash area configured via `FS_NOR_BM_Configure()`.

6.4.3.3.12 FS_NOR_BM_ResetStatCounters()

Description

Sets the value of the statistical counters to 0.

Prototype

```
void FS_NOR_BM_ResetStatCounters(U8 Unit);
```

Parameters

Parameter	Description
Unit	Index of the Block Map NOR driver (0-based).

Additional information

This function is optional. The application can use it to set the statistical counters maintained by the Block Map NOR driver to 0. The statistical counters can be read via `FS_NOR_BM_GetStatCounters()`

`FS_NOR_BM_ResetStatCounters()` is available only when the block map NOR driver is compiled with the `FS_DEBUG_LEVEL` configuration define set to a value greater than or equal to `FS_DEBUG_LEVEL_CHECK_ALL` or with the `FS_NOR_ENABLE_STATS` configuration define set to 1.

6.4.3.3.13 FS_NOR_BM_SuspendWearLeveling()

Description

Disables temporarily the wear leveling process.

Prototype

```
void FS_NOR_BM_SuspendWearLeveling(U8 Unit);
```

Parameters

Parameter	Description
Unit	Index of the Block Map NOR driver (0-based).

Additional information

This function is optional. Disabling the wear leveling can help reduce the write latencies that occur when the Block Map NOR driver has to make space for the new data by erasing storage blocks that contain invalid data. With the wear leveling disabled the Block Map NOR driver searches for an already empty block (i.e. a storage block that does not have to be erased before use) when it needs more space. Empty blocks are created when the application performs a clean operation via `FS_STORAGE_Clean()` or `FS_STORAGE_CleanOne()`. The wear leveling is automatically re-enabled by the Block Map NOR driver when no more empty storage blocks are available and an erase operation is required to create one.

`FS_NOR_BM_SuspendWearLeveling()` disables only the wear leveling operation performed when the file system writes data to NOR flash device. The wear leveling is still performed during a clean operation.

The activation status of the wear leveling is returned via the `IsWLSuspended` member of the `FS_NOR_BM_DISK_INFO` structure that can be queried via `FS_NOR_BM_GetDiskInfo()`

6.4.3.3.14 FS_NOR_BM_WriteOff()

Description

Writes data to NOR flash memory.

Prototype

```
int FS_NOR_BM_WriteOff(    U8    Unit,
                          const void * pData,
                          U32    Off,
                          U32    NumBytes);
```

Parameters

Parameter	Description
<code>Unit</code>	Index of the Block Map NOR driver (0-based).
<code>pData</code>	<code>in</code> Data to be written.
<code>Off</code>	Location where to write the data.
<code>NumBytes</code>	Number of bytes to be written.

Return value

= 0 OK, data written successfully.
 ≠ 0 An error occurred.

Additional information

`Off` has to be specified in bytes and is relative to the beginning of the NOR flash area configured via `FS_NOR_BM_Configure()`.

`FS_NOR_BM_WriteOff()` is able to write across page and physical sector boundaries. This function can only change bit values from 1 to 0. The bits can be set to 1 block-wise via `FS_NOR_BM_ErasePhySector()`.

The function takes care of the alignment required when writing to NOR flash devices with line size larger than 1.

6.4.3.3.15 FS_NOR_BM_DISK_INFO

Description

Management information maintained by the Block Map NOR driver.

Type definition

```
typedef struct {
    U16  NumPhySectors;
    U16  NumLogBlocks;
    U16  NumUsedPhySectors;
    U16  LSectorsPerPSector;
    U16  BytesPerSector;
    U32  EraseCntMax;
    U32  EraseCntMin;
    U32  EraseCntAvg;
    U8   HasFatalError;
    U8   ErrorType;
    U32  ErrorPSI;
    U8   IsWriteProtected;
    U8   IsWLSuspended;
    U32  MaxEraseCntDiff;
    U16  NumEraseCnt;
    U16  NumPhySectorsValid;
    U16  NumWorkBlocks;
} FS_NOR_BM_DISK_INFO;
```

Structure members

Member	Description
NumPhySectors	Number of physical sectors available for data storage.
NumLogBlocks	Number blocks available for the storage of file system data.
NumUsedPhySectors	Number of physical sectors that store valid data.
LSectorsPerPSector	Number of logical sectors that are mapped in a physical sector.
BytesPerSector	Size of the logical sector used by the driver in bytes.
EraseCntMax	Maximum value of an erase count.
EraseCntMin	Minimum value of an erase count.
EraseCntAvg	Average value of an erase count.
HasFatalError	Indicates if a fatal error has occurred during the operation (0 - no fatal error, 1 - a fatal error occurred)
ErrorType	Code indicating the type of fatal error that occurred.
ErrorPSI	Index of the physical sector where the fatal error occurred.
IsWriteProtected	Indicates if the NOR flash device has been switched permanently to read-only mode as a result of a fatal error (0 - NOR flash device is writable, 1 - NOR flash device is write protected)
IsWLSuspended	Indicates if the wear leveling process is temporarily suspended (0 - active, 1 - suspended)
MaxEraseCntDiff	Difference between the erase counts of two physical sectors that trigger an active wear leveling operation.
NumEraseCnt	Number of erase counts used for the calculation of the erase count average (EraseCntAvg)
NumPhySectorsValid	Number of physical sectors that have a valid header.
NumWorkBlocks	Number of work blocks used by the Block Map NOR driver.

6.4.3.3.16 FS_NOR_BM_MOUNT_INFO

Description

Information about the mounted NOR flash device.

Type definition

```
typedef struct {
    U16  NumPhySectors;
    U16  NumLogBlocks;
    U16  LSectorsPerPSector;
    U16  BytesPerSector;
    U8   HasFatalError;
    U8   ErrorType;
    U32  ErrorPSI;
    U8   IsWriteProtected;
    U8   IsWLSuspended;
    U16  NumWorkBlocks;
} FS_NOR_BM_MOUNT_INFO;
```

Structure members

Member	Description
NumPhySectors	Number of physical sectors available for data storage.
NumLogBlocks	Number blocks available for the storage of file system data.
LSectorsPerPSector	Number of logical sectors that are mapped in a physical sector.
BytesPerSector	Size of the logical sector used by the driver in bytes.
HasFatalError	Indicates if a fatal error has occurred during the operation (0 - no fatal error, 1 - a fatal error occurred)
ErrorType	Code indicating the type of fatal error that occurred.
ErrorPSI	Index of the physical sector where the fatal error occurred.
IsWriteProtected	Indicates if the NOR flash device has been switched permanently to read-only mode as a result of a fatal error (0 - NOR flash device is writable, 1 - NOR flash device is write protected)
IsWLSuspended	Indicates if the wear leveling process is temporarily suspended (0 - active, 1 - suspended)
NumWorkBlocks	Number of work blocks used by the Block Map NOR driver.

6.4.3.3.17 FS_NOR_BM_SECTOR_INFO

Description

Information about a physical sector maintained by the Block Map NOR driver.

Type definition

```
typedef struct {
    U32  Off;
    U32  Size;
    U32  EraseCnt;
    U16  lbi;
    U8   Type;
} FS_NOR_BM_SECTOR_INFO;
```

Structure members

Member	Description
Off	Position of the physical sector relative to the first byte of NOR flash device
Size	Size of physical sector in bytes
EraseCnt	Number of times the physical sector has been erased
lbi	Index of the logical block stored in the physical sector
Type	Type of data stored in the physical sector (see FS_NOR_BLOCK_TYPE_...)

6.4.3.3.17.1 FS_NOR_BM_STAT_COUNTERS

Description

Statistical counters maintained by the Block Map NOR driver.

Type definition

```
typedef struct {
    U32  NumFreeBlocks;
    U32  EraseCnt;
    U32  ReadSectorCnt;
    U32  WriteSectorCnt;
    U32  ConvertViaCopyCnt;
    U32  ConvertInPlaceCnt;
    U32  NumValidSectors;
    U32  CopySectorCnt;
    U32  NumReadRetries;
    U32  ReadPSHCnt;
    U32  WritePSHCnt;
    U32  ReadLSHCnt;
    U32  WriteLSHCnt;
    U32  ReadCnt;
    U32  ReadByteCnt;
    U32  WriteCnt;
    U32  WriteByteCnt;
    U32  BitErrorCnt;
    U32  aBitErrorCnt[];
    U32  PreEraseCnt;
} FS_NOR_BM_STAT_COUNTERS;
```

Structure members

Member	Description
NumFreeBlocks	Number of blocks that are not used for data storage.
EraseCnt	Number of sector erase operations.
ReadSectorCnt	Number of logical sectors read by the file system.
WriteSectorCnt	Number of logical sectors written by the file system.
ConvertViaCopyCnt	Number of times a work block has been converted via a copy operation.
ConvertInPlaceCnt	Number of times a work block has been converted in-place (i.e. by changing the block type from work to data).
NumValidSectors	Number of valid logical sectors stored on the NOR flash device.
CopySectorCnt	Number of logical sectors copied internally by the driver.
NumReadRetries	Number of times the driver retried a read operation due to an error.
ReadPSHCnt	Number of times the driver read from the header of a physical sector.
WritePSHCnt	Number of times the driver wrote to the header of a physical sector.
ReadLSHCnt	Number of times the driver read from the header of a logical sector.
WriteLSHCnt	Number of times the driver wrote to the header of a logical sector.
ReadCnt	Number of times the driver read data from the NOR flash device.

Member	Description
<code>ReadByteCnt</code>	Number of bytes read by the driver from the NOR flash device.
<code>WriteCnt</code>	Number of times the driver wrote data to the NOR flash device.
<code>WriteByteCnt</code>	Number of bytes written by the driver to the NOR flash device.
<code>BitErrorCnt</code>	Total number of bit errors corrected.
<code>aBitErrorCnt</code>	Number of times a specific number of bit errors occurred.
<code>PreEraseCnt</code>	Number of sector pre-erase operations.

Additional information

The statistical counters can be queried via `FS_NOR_BM_GetStatCounters()` and can be set to 0 via `FS_NOR_BM_ResetStatCounters()`.

`aBitErrorCnt[0]` stores the number of 1 bit error occurrences, `aBitErrorCnt[1]` stores the number of 2 bit error occurrences, and so on.

`PreEraseCnt` stores the number of times the Block Map NOR driver marked a physical sector as ready to be erased. The physical sectors are then erased before being used.

6.4.3.4 Performance and resource usage

6.4.3.4.1 ROM usage

The ROM usage depends on the compiler options, the compiler version and the used CPU. The memory requirements of the Sector Map NOR driver were measured as described in the section *Test procedure* on page 1283.

Usage: 5.5 Kbytes

6.4.3.4.2 Static RAM usage

Static RAM usage refers to the amount of RAM required by the Block Map NOR driver internally for all the driver instances. The number of bytes can be seen in the compiler list file of the `FS_NOR_BM_Drv.c` file.

Usage: 72 bytes

6.4.3.4.3 Dynamic RAM usage

Dynamic RAM usage is the amount of RAM allocated by the driver at runtime. The amount of RAM required depends on the runtime configuration and on the used NOR flash device. The approximate RAM usage of the Block Map NOR driver can be calculated as follows:

```
MemAllocated = 84
               + (24 + PhySectorSize / LogSectorSize) * NumWorkBlocks
               + 1.5 * NumPhySectors
```

Parameter	Description
MemAllocated	Number of bytes allocated.
PhySectorSize	Size in bytes of a NOR flash physical sector.
LogSectorSize	Size in bytes of a file system sector. Typically 512 bytes or the value set in the call to <code>FS_SetMaxSectorSize()</code> configuration function.
NumWorkBlocks	Number of physical sectors the driver reserves as temporary storage for the written data. Typically 3 physical sectors or the number specified in the call to the <code>FS_NOR_BM_SetNumWorkBlocks()</code> configuration function.
NumPhySectors	Number of physical sectors managed by the driver.

6.4.3.4.4 Performance

These performance measurements are in no way complete, but they give an approximation of the length of time required for common operations on various targets. The tests were performed as described in the section *Performance* on page 1289. All values are given in Kbytes/second

CPU type	NOR flash device	Write speed	Read speed
NXP LPC2478 (57.6 MHz)	SST SST39VF201 CFI NOR flash device with 16-bit interface and without support for write buffer	45.5	2064
ST STM32F103 (72 MHz)	ST M25P64 serial NOR flash device	59.3	1110
NXP LPC4357 (204 MHz)	Two Spansion S29GL064N CFI NOR flash devices with 16-bit interface and with support for write buffer.	179	25924

6.4.4 NOR physical layer

6.4.4.1 General information

The NOR physical layer provides the basic functionality for accessing a NOR flash device such as device identification, block erase operation, read and write operations, etc. Every instance of the Sector map or Block Map NOR driver requires an instance of a NOR physical layer in order to be able to operate. A NOR physical layer instance is automatically allocated either statically or dynamically at the first call to one of its API functions. Each instance is identified by a unit number that is identical with the unit number of the NOR driver that uses that instance of the NOR physical layer. The type of the NOR physical layer assigned to an instance of a Sector map or Block Map NOR driver is configured via `FS_NOR_SetPhyType()` and `FS_NOR_BM_SetPhyType()` respectively.

The table below lists the NOR physical layers that ship with emFile. Refer to *Configuring the driver* on page 738 and *Configuring the driver* on page 776 for detailed information about how to add and configure a physical layer in an application.

Physical layer identifier	Hardware layer type
FS_NOR_PHY_CFI_1x16	Not required.
FS_NOR_PHY_CFI_2x16	Not required.
FS_NOR_PHY_DSPI	FS_NOR_HW_TYPE_SPI
FS_NOR_PHY_SFDP	FS_NOR_HW_TYPE_SPI
FS_NOR_PHY_SPIFI	FS_NOR_HW_TYPE_SPIFI
FS_NOR_PHY_ST_M25	FS_NOR_HW_TYPE_SPI

The following sections provide information about the usage and the implementation of a NOR physical layer.

6.4.4.2 CFI 1x16 physical layer

This physical layer supports any CFI compliant NOR flash device connected via a 16-bit data bus.

The physical layer has to be configured at runtime and optionally at compile time. The following sections described how this can be realized in the application.

6.4.4.2.1 Compile time configuration

The CFI 1x16 physical layer can optionally be configured at compile time. Typically, this step can be omitted because reasonable default values are provided that work with most of the applications. The following table provides a summary of the configuration defines supported by this physical layer.

Define	Default value	Type	Description
FS_NOR_AMD_WRITE_BUFFER_SIZE	32	N	Size of the internal write buffer of AMD compatible NOR flash devices in bytes.
FS_NOR_AMD_STATUS_CHECK_TYPE	0	N	Configures how the status of a program and erase operation should be checked.
FS_NOR_DMB()	empty	F	Macro to synchronize the access to memory.
FS_NOR_DELAY()	empty	F	Macro to block the execution for a fixed time interval.
FS_NOR_DI()	empty	F	Macro to disable the interrupts globally.
FS_NOR_EI()	empty	F	Macro to enable the interrupts globally.
FS_NOR_FAR	empty	R	Memory type specifier. Used for 8/16-bit CPUs only.
FS_NOR_INTEL_WRITE_BUFFER_SIZE	32	N	Size of the internal write buffer of Intel compatible NOR flash devices in bytes.
FS_NOR_MAX_SECTOR_BLOCKS	6	N	Maximum number of different physical sector sizes that can be handled.
FS_NOR_REVERSE_ENDIANNESS	0	B	

6.4.4.2.1.1 FS_NOR_AMD_WRITE_BUFFER_SIZE

FS_NOR_AMD_WRITE_BUFFER_SIZE specifies the maximum number of bytes the NOR flash device is able to buffer internally before the data is written to memory array. This define is relevant only for NOR flash devices that comply with the AMD command set.

6.4.4.2.1.2 FS_NOR_AMD_STATUS_CHECK_TYPE

FS_NOR_AMD_STATUS_CHECK_TYPE specifies how the physical layer waits for a write or erase operation to complete. The following values are permitted:

Value	Description
0	The status is checked by polling the toggle bit. No error checking is possible because the devices do not provide this information. Typically, this polling mode is supported by legacy NOR flash devices. This is the default behavior for backward compatibility.

Value	Description
1	The status is checked by polling toggle bit. In addition, the status of the erase and write operation is checked for errors. This polling mode is supported by modern NOR flash devices such as from Micron.
2	The status is checked by polling the status register. This polling mode is supported by Cypress HyperFlash devices.

6.4.4.2.1.3 FS_NOR_DMB()

`FS_NOR_DMB()` specifies a function that the file system can call to make sure that a code sequence is executed only after all the previous memory accesses are finished. On a Cortex-M architecture this macro has to expand to a DMB instruction.

6.4.4.2.1.4 FS_NOR_DELAY()

`FS_NOR_DELAY()` specifies a function that blocks the execution for a certain period of time. The function does not take any parameters and returns void. It is called each time the physical layer is checking for the completion status of a write or erase operation. For performance reasons, the amount of time the function blocks should be configured to be smaller than the time required by the NOR flash device to complete a write or erase operation. Using this feature can help reduce the CPU usage of the file system.

6.4.4.2.1.5 FS_NOR_DI()

`FS_NOR_DI()` specifies a function that disables the interrupts globally. The function does not take any parameters and returns void. The specified function is called after each access to the memory region where the NOR flash device is mapped in the system memory.

6.4.4.2.1.6 FS_NOR_EI()

`FS_NOR_EI()` specifies a function that enables the interrupts globally. The function does not take any parameters and returns void. The specified function is called before each access to the memory region where the NOR flash device is mapped in the system memory.

6.4.4.2.1.7 FS_NOR_FAR

`FS_NOR_FAR` is a memory type specifier that is used to cast the pointers used for the access to the memory region where NOR flash device is mapped in the system memory. This configuration define is C compiler specific and is typically required only on 8- or 16-bit targets.

6.4.4.2.1.8 FS_NOR_INTEL_WRITE_BUFFER_SIZE

`FS_NOR_INTEL_WRITE_BUFFER_SIZE` specifies the maximum number of bytes the NOR flash device is able to buffer internally before the data is written to memory array. This define is relevant only for NOR flash devices that comply with the Intel command set.

6.4.4.2.1.9 FS_NOR_MAX_SECTOR_BLOCKS

`FS_NOR_MAX_SECTOR_BLOCKS` specifies the number of different physical sector sizes that the physical layer can handle. This define can be set to 1 for NOR flash devices with physical sectors of the same size.

6.4.4.2.1.10 FS_NOR_REVERSE_ENDIANESS

`FS_NOR_REVERSE_ENDIANESS` specifies if the byte ordering of the CFI information has to be reversed because it is not presented in the byte ordering expected by the CPU.

6.4.4.2.2 Runtime configuration

The API functions listed in the following table can be used by the application to configure the behavior of the CFI 1x16 physical layer. The application can call them only at the file system initialization in `FS_X_AddDevices()`.

Function	Description
<code>FS_NOR_CFI_SetAddrGap()</code>	Configures a memory access gap.
<code>FS_NOR_CFI_SetReadCFICallback()</code>	Registers a read function for the CFI parameters.

6.4.4.2.2.1 FS_NOR_CFI_SetAddrGap()

Description

Configures a memory access gap.

Prototype

```
void FS_NOR_CFI_SetAddrGap(U8 Unit,
                           U32 StartAddr,
                           U32 NumBytes);
```

Parameters

Parameter	Description
Unit	Index of the physical layer (0-based)
StartAddr	Address of the first byte in the gap.
NumBytes	Number of bytes in the gap.

Additional information

This function is optional. The application can use `FS_NOR_CFI_SetAddrGap()` to specify a range in the memory region where the contents of the NOR flash device is mapped that is not assigned to the NOR flash device. Any access to an address equal to or greater than `StartAddr` is translated by `NumBytes`. `StartAddr` and `NumBytes` have to be aligned to a physical sector boundary of the used NOR flash device.

The application is permitted to call `FS_NOR_CFI_SetAddrGap()` only during the file system initialization in `FS_X_AddDevices()`.

Example

```
#include "FS.h"

#define ALLOC_SIZE          0x4000
#define FLASH_BASE_ADDR    0x80000000
#define FLASH_START_ADDR   0x80000000
#define FLASH_SIZE         0x00400000
#define FLASH_GAP_START_ADDR 0x80200000
#define FLASH_GAP_SIZE     0x00200000

static U32 _aMemBlock[ALLOC_SIZE / 4]; // Memory pool used for
                                        // semi-dynamic allocation.

/*****
 *
 *      FS_X_AddDevices
 *
 *      Function description
 *      This function is called by the FS during FS_Init().
 */
void FS_X_AddDevices(void) {
    //
    // Give the file system memory to work with.
    //
    FS_AssignMemory(&_aMemBlock[0], sizeof(_aMemBlock));
    //
    // Add and configure the driver for a 4MB NOR flash.
    //
    FS_AddDevice(&FS_NOR_Driver);
    FS_NOR_SetPhyType(0, &FS_NOR_PHY_CFI_1x16);
    FS_NOR_Configure(0, FLASH_BASE_ADDR, FLASH_START_ADDR, FLASH_SIZE);
    //
    // Configure a 2MB gap in the address space of NOR flash.
    //
    FS_NOR_CFI_SetAddrGap(0, FLASH_GAP_START_ADDR, FLASH_GAP_SIZE);
}
```

6.4.4.2.2 FS_NOR_CFI_SetReadCFICallback()

Description

Registers a read function for the CFI parameters.

Prototype

```
void FS_NOR_CFI_SetReadCFICallback(U8 Unit,
                                   FS_NOR_READ_CFI_CALLBACK * pReadCFI);
```

Parameters

Parameter	Description
Unit	Index of the physical layer (0-based)
pReadCFI	Function to be registered.

Additional information

This function is optional. It can be used to specify a different function for the reading of CFI parameters than the default function used by the physical layer. This is typically required when the CFI parameters do not fully comply with the CFI specification.

The application is permitted to call `FS_NOR_CFI_SetReadCFICallback()` only during the file system initialization in `FS_X_AddDevices()`.

Example

```
#include "FS.h"

#define ALLOC_SIZE          0x4000    // Size defined in bytes
#define BYTES_PER_SECTOR  2048

#define CFI_READCONFIG(BaseAddr)      // TBD
#define CFI_RESET(BaseAddr)          // TBD
#define CFI_READCONFIG_NON_CONFORM(BaseAddr) // TBD

static U32 _aMemBlock[ALLOC_SIZE / 4]; // Memory pool used for
                                       // semi-dynamic allocation.

static int _IsInited = 0;
static int _IsCFICompliant = 0;

/*****
 *
 *   _cbReadCFI
 *
 */
static void _cbReadCFI(U8 Unit, U32 BaseAddr, U32 Off, U8 * pData, unsigned NumItems) {
    volatile U16 FS_NOR_FAR * pAddr;
    U8 aData[3];

    FS_USE_PARA(Unit);
    //
    // We initially need to check whether the flash is fully CFI compliant.
    //
    if (_IsInited == 0) {
        FS_MEMSET(aData, 0, sizeof(aData));
        pAddr = (volatile U16 FS_NOR_FAR *) (BaseAddr + (0x10 << 1));
        CFI_READCONFIG(BaseAddr);
        aData[0] = (U8)*pAddr++;
        aData[1] = (U8)*pAddr++;
        aData[2] = (U8)*pAddr++;
        CFI_RESET(BaseAddr);
        if ( (aData[0] == 'Q')
            && (aData[1] == 'R')
            && (aData[2] == 'Y')) {
            _IsCFICompliant = 1;
        }
        _IsInited = 1;
    }
    pAddr = (volatile U16 FS_NOR_FAR *) (BaseAddr + (Off << 1));
```

```

//
// Write the correct CFI-query sequence
//
if (_IsCFICompliant) {
    CFI_READCONFIG(BaseAddr);
} else {
    CFI_READCONFIG_NON_CONFORM(BaseAddr);
}
//
// Read the data
//
do {
    *pData++ = (U8)*pAddr++; // Only the low byte of the CFI data is relevant
} while(--NumItems);
//
// Perform a reset, which means, return from CFI mode to normal mode
//
CFI_RESET(BaseAddr);
}

/*****
*
*     FS_X_AddDevices
*
* Function description
* This function is called by the FS during FS_Init().
*/
void FS_X_AddDevices(void) {
    //
    // Give the file system memory to work with.
    //
    FS_AssignMemory(&aMemBlock[0], sizeof(_aMemBlock));
    //
    // Add and configure the NOR flash driver.
    //
    FS_AddDevice(&FS_NOR_Driver);
    FS_NOR_SetPhyType(0, &FS_NOR_PHY_CFI_1x16);
    //
    // Configure a different function for reading CFI information.
    //
    FS_NOR_CFI_SetReadCFICallback(0, _cbReadCFI);
    FS_NOR_Configure(0, 0x10000000, 0x10000000, 0xFFFFFFFF);
    FS_NOR_SetSectorSize(0, BYTES_PER_SECTOR);
    //
    // Set a larger logical sector size as the default
    // in order to reduce the RAM usage of the NOR driver.
    //
    FS_SetMaxSectorSize(BYTES_PER_SECTOR);
}

```

6.4.4.2.2.3 FS_NOR_READ_CFI_CALLBACK

Description

Reads CFI information from a NOR flash device.

Type definition

```
typedef void (FS_NOR_READ_CFI_CALLBACK)(U8      Unit,
                                         U32      BaseAddr,
                                         U32      Off,
                                         U8      * pData,
                                         unsigned NumItems);
```

Parameters

Parameter	Description
<code>Unit</code>	Index of the physical layer (0-based).
<code>BaseAddr</code>	Address in system memory where the NOR flash device is mapped.
<code>Off</code>	Byte offset to read from.
<code>pData</code>	out CFI information read
<code>NumItems</code>	Number of 16-bit values to be read.

Additional information

This is the type of the callback function invoked by CFI NOR physical layers to read CFI information from NOR flash device. The CFI NOR physical layers already have an internal function for reading the CFI information. `FS_NOR_CFI_SetReadCFICallback()` can be used to register a callback function that replaces the functionality of this internal function.

Example

Refer to `FS_NOR_CFI_SetReadCFICallback()` for a sample usage.

6.4.4.3 CFI 2x16 physical layer

This physical layer supports any setup with two CFI compliant NOR flash devices each one being connected via a 16-bit data bus. It can be configured at compile time as well as at runtime in the same way as the CFI 1x16 physical layer.

6.4.4.4 DSPI physical layer

This is a pseudo physical layer that uses the ST M25 and SFDP physical layers to access a serial NOR flash device. The data is exchanged via 1 SPI data line.

The DSPI physical layer has to be configured at runtime and optionally at compile time. The following sections describe how this can be realized in the application.

6.4.4.4.1 Compile time configuration

The DSPI physical layer uses the same configuration defines as the ST M25 and SFDP physical layers. Refer to *Compile time configuration* on page 874 and *Compile time configuration* on page 851 for more information.

6.4.4.4.2 Runtime configuration

The API functions listed in the following table can be used by the application to configure the behavior of the DSPI physical layer. The application can call them only at the file system initialization in `FS_X_AddDevices()`.

Function	Description
<code>FS_NOR_DSPI_SetHWType()</code>	Configures the HW access routines.

6.4.4.4.2.1 FS_NOR_DSPI_SetHWType()

Description

Configures the HW access routines.

Prototype

```
void FS_NOR_DSPI_SetHWType(          U8          Unit,  
                             const FS_NOR_HW_TYPE_SPI * pHWType);
```

Parameters

Parameter	Description
Unit	Index of the physical layer (0-based).
pHWType	Hardware access routines. Cannot be NULL.

Additional information

This function is mandatory and it has to be called once for each instance of the physical layer.

6.4.4.5 SFDP physical layer

This physical layer supports any serial NOR flash device that complies with the JEDEC JESD216 specification. This specification standardizes the method of describing the capabilities of a serial NOR flash device. This information is stored internally by any compatible serial NOR flash device and is used by the SFDP physical layer to determine the capacity of the serial NOR flash device, the codes of single, dual, and quad read commands and so on.

6.4.4.5.1 Compile time configuration

The SFDP physical layer can optionally be configured at compile time. Typically, this step can be omitted because reasonable default values are provided that work with most of the applications. The following table provides a summary of the configuration defines supported by this physical layer.

Define	Default value	Type	Description
<code>FS_NOR_BYTES_PER_PAGE</code>	256	N	Maximum number of bytes that can be stored at once to a NOR flash page.
<code>FS_NOR_DELAY_SECTOR_ERASE</code>	0	N	Delay in milliseconds between two status requests sent when waiting for the completion of the erase operation.
<code>FS_NOR_DEVICE_LIST_DEFAULT</code>	<code>&FS_NOR_SPI_DeviceListDefault</code>	De-R	Default list of NOR flash devices that can be handled.
<code>FS_NOR_TIMEOUT_PAGE_WRITE</code>	5	N	Timeout in milliseconds for the page program operation.
<code>FS_NOR_TIMEOUT_SECTOR_ERASE</code>	3000	N	Timeout in milliseconds for the sector erase operation.

6.4.4.5.1.1 FS_NOR_BYTES_PER_PAGE

`FS_NOR_BYTES_PER_PAGE` specifies the maximum number of bytes that can be written at once by the serial NOR flash device. This value can be taken from the data sheet of the device. A write operation with a number of bytes larger than `FS_NOR_BYTES_PER_PAGE` is split by the physical layer into multiple write operations with a number of bytes smaller than or equal to `FS_NOR_BYTES_PER_PAGE`.

6.4.4.5.1.2 FS_NOR_DELAY_SECTOR_ERASE

`FS_NOR_DELAY_SECTOR_ERASE` specifies the number of milliseconds the physical layer has to wait between two device status request. A device status request is performed by the physical layer when it waits for an erase operation to complete. Using this feature can help reduce the CPU usage of the file system.

6.4.4.5.1.3 FS_NOR_DEVICE_LIST_DEFAULT

`FS_NOR_DEVICE_LIST_DEFAULT` specifies the list of serial NOR flash devices that can be handled by the physical layer. `FS_NOR_DEVICE_LIST_DEFAULT` can be set to `NULL` in order to reduce the ROM usage if not all the devices included in `FS_NOR_SPI_DeviceListDefault` have to be handled. In this case it is mandatory that the application configures a list of devices via `FS_NOR_SFDP_SetDeviceList()`.

6.4.4.5.1.4 FS_NOR_TIMEOUT_PAGE_WRITE

`FS_NOR_TIMEOUT_PAGE_WRITE` specifies the maximum number of milliseconds the physical layer has to wait for a write operation to complete. The completion of the write operation is determined by evaluating the value returned by the serial NOR flash device to a status request.

6.4.4.5.1.5 FS_NOR_TIMEOUT_SECTOR_ERASE

FS_NOR_TIMEOUT_SECTOR_ERASE specifies the maximum number of milliseconds the physical layer has to wait for a physical sector erase operation to complete. The completion of the erase operation is determined by evaluating the value returned by the serial NOR flash device to a status request.

6.4.4.5.2 Runtime configuration

The API functions listed in the following table can be used by the application to configure the behavior of the SFDP physical layer. The application can call them only at the file system initialization in FS_X_AddDevices().

Function	Description
FS_NOR_SFDP_Allow2bitMode()	Specifies if the physical layer is permitted to exchange data via two data lines.
FS_NOR_SFDP_Allow4bitMode()	Specifies if the physical layer is permitted to exchange data via four data lines.
FS_NOR_SFDP_Configure()	Configures an instance of the physical layer.
FS_NOR_SFDP_SetDeviceList()	Configures the type of handled serial NOR flash devices.
FS_NOR_SFDP_SetDeviceParaList()	Configures parameters of serial NOR flash devices.
FS_NOR_SFDP_SetHWType()	Configures the HW access routines.
FS_NOR_SFDP_SetSectorSize()	Configures the size of the physical sector to be used by the driver.

6.4.4.5.2.1 FS_NOR_SFDP_Allow2bitMode()

Description

Specifies if the physical layer is permitted to exchange data via two data lines.

Prototype

```
void FS_NOR_SFDP_Allow2bitMode(U8 Unit,
                               U8 OnOff);
```

Parameters

Parameter	Description
<code>Unit</code>	Index of the physical layer (0-based).
<code>OnOff</code>	Activation status of the option. <ul style="list-style-type: none"> • 0 Disable the option. • 1 Enable the option.

Additional information

This function is optional. By default the data is exchanged via one data line (standard SPI). The data transfer via two data lines is used only if this type of data transfer is supported by the serial NOR flash device. In dual mode two bits of data are transferred with each clock period which helps improve the performance. If the serial NOR flash device does not support the dual mode then the data is transferred in standard mode (one data bit per clock period).

The application is permitted to call this function only at the file system initialization in `FS_X_AddDevices()`.

6.4.4.5.2.2 FS_NOR_SFDP_Allow4bitMode()

Description

Specifies if the physical layer is permitted to exchange data via four data lines.

Prototype

```
void FS_NOR_SFDP_Allow4bitMode(U8 Unit,
                               U8 OnOff);
```

Parameters

Parameter	Description
<code>Unit</code>	Index of the physical layer (0-based).
<code>OnOff</code>	Activation status of the option. <ul style="list-style-type: none"> • 0 Disable the option. • 1 Enable the option.

Additional information

This function is optional. By default the data is exchanged via one data line (standard SPI). The data transfer via four data lines is used only if this type of data transfer is supported by the serial NOR flash device. In quad mode four bits of data are transferred on each clock period which helps improve the performance. If the serial NOR flash device does not support the quad mode then the data is transferred in dual mode if enabled and supported or in standard mode (one bit per clock period).

The application is permitted to call this function only at the file system initialization in `FS_X_AddDevices()`.

6.4.4.5.2.3 FS_NOR_SFDP_Configure()

Description

Configures an instance of the physical layer.

Prototype

```
void FS_NOR_SFDP_Configure(U8 Unit,
                          U32 StartAddr,
                          U32 NumBytes);
```

Parameters

Parameter	Description
<code>Unit</code>	Index of the SFDP physical layer (0-based).
<code>StartAddr</code>	Address of the first byte the SFDP physical layer is permitted to use as storage.
<code>NumBytes</code>	Number of bytes starting from <code>StartAddr</code> available to be used by the SFDP physical layer as storage.

Additional information

This function is optional. It can be called instead of the `FS_NOR_BM_Configure()` or `FS_NOR_Configure()`. Different instances of the SFDP physical layer are identified by the `Unit` parameter.

`BaseAddr` is used only for NOR flash devices that are memory mapped. For serial NOR flash devices that are not memory mapped `BaseAddr` has to be set to 0.

`StartAddr` has to be greater than or equal to `BaseAddr` and smaller than the total number of bytes in the NOR flash device. The SFDP physical layer rounds up `StartAddr` to the start address of the next physical sector in the NOR flash device.

`NumBytes` is rounded up to a physical sector boundary if the memory range defined by `StartAddr` and `NumBytes` is smaller than the capacity of the NOR flash device. If the memory range defined by `StartAddr` and `NumBytes` is larger than the capacity of the NOR flash device than `NumBytes` is rounded down so that the memory range fits into the NOR flash device.

6.4.4.5.2.4 FS_NOR_SFDP_SetDeviceList()

Description

Configures the type of handled serial NOR flash devices.

Prototype

```
void FS_NOR_SFDP_SetDeviceList(      U8          Unit,
                                   const FS_NOR_SPI_DEVICE_LIST * pDeviceList);
```

Parameters

Parameter	Description
<code>Unit</code>	Index of the physical layer (0-based).
<code>pDeviceList</code>	List of NOR flash devices the physical layer can handle.

Additional information

This function is optional. This function can be used to enable handling for vendor specific features of serial NOR flash device such as error handling and data protection. By default the physical layer is configured to handle only Micron serial NOR flash devices. Handling for serial NOR flash devices from other manufacturers has to be explicitly enabled via this function.

Permitted values for the `pDeviceList` parameter are:

Identifier	Description
<code>FS_NOR_SPI_DeviceListAdesto</code>	Enables handling of Adesto serial NOR flash devices.
<code>FS_NOR_SPI_DeviceListAll</code>	Enables handling of serial NOR flash devices from all manufacturers.
<code>FS_NOR_SPI_DeviceListCypress</code>	Enables handling of Cypress serial NOR flash devices.
<code>FS_NOR_SPI_DeviceListDefault</code>	Enables handling of Micron and of SFDP compatible serial NOR flash devices.
<code>FS_NOR_SPI_DeviceListEon</code>	Enables handling of Eon serial NOR flash devices.
<code>FS_NOR_SPI_DeviceListGigaDevice</code>	Enables handling of GigaDevice serial NOR flash devices.
<code>FS_NOR_SPI_DeviceListISSI</code>	Enables handling of ISSI serial NOR flash devices.
<code>FS_NOR_SPI_DeviceListMacronix</code>	Enables handling of Macronix serial NOR flash devices.
<code>FS_NOR_SPI_DeviceListMicron</code>	Enables handling of Micron serial NOR flash devices.
<code>FS_NOR_SPI_DeviceListMicron_x</code>	Enables handling of Micron serial NOR flash devices in single and dual chip setups.
<code>FS_NOR_SPI_DeviceListMicron_x2</code>	Enables handling of Micron serial NOR flash devices in dual chip setups.
<code>FS_NOR_SPI_DeviceListMicrochip</code>	Enables handling of Microchip serial NOR flash devices.
<code>FS_NOR_SPI_DeviceListSpansion</code>	Enables handling of Spansion serial NOR flash devices.
<code>FS_NOR_SPI_DeviceListSTM</code>	Enables handling of STMicroelectronics serial NOR flash devices.

Identifier	Description
FS_NOR_SPI_DeviceListWinbond	Enables handling of Winbond serial NOR flash devices.

The application can save ROM space by setting `FS_NOR_DEVICE_LIST_DEFAULT` to `NULL` at compile time and by calling at runtime `FS_NOR_SFDP_SetDeviceList()` with the actual list of serial NOR flash devices that have to be handled.

The application is permitted to call this function only at the file system initialization in `FS_X_AddDevices()`.

6.4.4.5.2.5 FS_NOR_SFDP_SetDeviceParaList()

Description

Configures parameters of serial NOR flash devices.

Prototype

```
void FS_NOR_SFDP_SetDeviceParaList
(
    U8 Unit,
    const FS_NOR_SPI_DEVICE_PARA_LIST * pDeviceParaList);
```

Parameters

Parameter	Description
Unit	Index of the physical layer (0-based).
pDeviceParaList	List of device parameters.

Additional information

This function is optional. By default, the parameters of the used serial NOR flash device are determined by evaluating the SFDP tables stored in it. However, the information about the commands that can be used to write the data via two and four data lines is not stored to this parameters. `FS_NOR_SFDP_SetDeviceParaList()` can be used to specify this information. The parameters are matched by comparing the first byte (manufacturer id) and the third byte (device id) of the information returned by the READ ID (0x9F) function with the MfgId and Id members of the `FS_NOR_SPI_DEVICE_PARA` structure.

The application is permitted to call this function only at the file system initialization in `FS_X_AddDevices()`.

6.4.4.5.2.6 FS_NOR_SFDP_SetHWType()

Description

Configures the HW access routines.

Prototype

```
void FS_NOR_SFDP_SetHWType(      U8          Unit,  
                               const FS_NOR_HW_TYPE_SPI * pHWType);
```

Parameters

Parameter	Description
<code>Unit</code>	Index of the physical layer (0-based).
<code>pHWType</code>	Hardware access routines. Cannot be NULL.

Additional information

It is mandatory to call this function during the file system initialization in `FS_X_AddDe-`
`vices()` once for each instance of a physical layer.

6.4.4.5.2.7 FS_NOR_SFDP_SetSectorSize()

Description

Configures the size of the physical sector to be used by the driver.

Prototype

```
void FS_NOR_SFDP_SetSectorSize(U8 Unit,  
                               U32 BytesPerSector);
```

Parameters

Parameter	Description
<code>Unit</code>	Index of the physical layer (0-based).
<code>BytesPerSector</code>	Sector size to be used.

Additional information

Typically, a serial NOR flash device supports erase commands that can be used to erase sectors of different sizes (4 KB, 32 KB, etc.) For performance reasons the physical layer chooses always the erase command corresponding to the largest physical sector. This function can be used to request the physical layer to use a different (smaller) physical sector size. The mount operation fails if the serial NOR flash device does not support the specified physical sector size.

The application is permitted to call this function only at the file system initialization in `FS_X_AddDevices()`.

6.4.4.5.2.8 FS_NOR_SPI_DEVICE_PARA_LIST

Description

Defines a list of serial NOR flash device parameters.

Type definition

```
typedef struct {  
    U8                               NumParas;  
    const FS_NOR_SPI_DEVICE_PARA * pPara;  
} FS_NOR_SPI_DEVICE_PARA_LIST;
```

Structure members

Member	Description
NumParas	Number of parameters
pPara	List of parameters.

6.4.4.6 SPIFI physical layer

This physical layer supports serial NOR flash devices that are mapped to the system memory of the target system. The SPIFI physical layer is able to make use of the SFDP information stored to the interfaced NOR flash device in order to determine the storage geometry and the supported command set of that device.

6.4.4.6.1 Compile configuration

The SPIFI physical layer can optionally be configured at compile time. Typically, this step can be omitted because reasonable default values are provided that work with most of the applications. The following table provides a summary of the configuration defines supported by this physical layer.

Define	Default value	Type	Description
<code>FS_NOR_BYTES_PER_PAGE</code>	256	N	Maximum number of bytes that can be stored at once to a NOR flash page.
<code>FS_NOR_DELAY_SECTOR_ERASE</code>	0	N	Delay in milliseconds between two status requests sent when waiting for the completion of the erase operation.
<code>FS_NOR_DEVICE_LIST_DEFAULT</code>	<code>&FS_NOR_SPI_DeviceListDefault</code>	De-R	Default list of NOR flash devices that can be handled.
<code>FS_NOR_MAX_NUM_BYTES_DUMMY</code>	5	N	Maximum number of dummy bytes required during a read operation the physical layer can handle.
<code>FS_NOR_TIMEOUT_PAGE_WRITE</code>	5	N	Timeout in milliseconds for the page program operation.
<code>FS_NOR_TIMEOUT_SECTOR_ERASE</code>	3000	N	Timeout in milliseconds for the sector erase operation.

6.4.4.6.1.1 FS_NOR_BYTES_PER_PAGE

`FS_NOR_BYTES_PER_PAGE` specifies the maximum number of bytes that can be written at once by the serial NOR flash device. This value can be taken from the data sheet of the device. A write operation with a number of bytes larger than `FS_NOR_BYTES_PER_PAGE` is split by the physical layer into multiple write operations with a number of bytes smaller than or equal to `FS_NOR_BYTES_PER_PAGE`.

6.4.4.6.1.2 FS_NOR_DELAY_SECTOR_ERASE

`FS_NOR_DELAY_SECTOR_ERASE` specifies the number of milliseconds the physical layer has to wait between two device status request. A device status request is performed by the physical layer when it waits for an erase operation to complete. Using this feature can help reduce the CPU usage of the file system.

6.4.4.6.1.3 FS_NOR_DEVICE_LIST_DEFAULT

`FS_NOR_DEVICE_LIST_DEFAULT` specifies the list of serial NOR flash devices that can be handled by the physical layer. `FS_NOR_DEVICE_LIST_DEFAULT` can be set to `NULL` in order to reduce the ROM usage if not all the devices included in `FS_NOR_SPI_DeviceListDefault` have to be handled. In this case it is mandatory that the application configures a list of devices via `FS_NOR_SFDP_SetDeviceList()`.

6.4.4.6.1.4 FS_NOR_MAX_NUM_BYTES_DUMMY

`FS_NOR_MAX_NUM_BYTES_DUMMY` specifies the maximum number of dummy bytes the physical layer can send when executing a read operation. The dummy bytes are necessary in

order to give the serial NOR flash device to prepare the data. The information about the actual number of dummy bytes required is read by the physical layer from the serial NOR flash device via SFDP.

6.4.4.6.1.5 FS_NOR_TIMEOUT_PAGE_WRITE

`FS_NOR_TIMEOUT_PAGE_WRITE` specifies the maximum number of milliseconds the physical layer has to wait for a write operation to complete. The completion of the write operation is determined by evaluating the value returned by the serial NOR flash device to a status request.

6.4.4.6.1.6 FS_NOR_TIMEOUT_SECTOR_ERASE

`FS_NOR_TIMEOUT_SECTOR_ERASE` specifies the maximum number of milliseconds the physical layer has to wait for a physical sector erase operation to complete. The completion of the erase operation is determined by evaluating the value returned by the serial NOR flash device to a status request.

6.4.4.6.2 Runtime configuration

The API functions listed in the following table can be used by the application to configure the behavior of the SPIFI physical layer. The application can call them only at the file system initialization in `FS_X_AddDevices()`.

Function	Description
<code>FS_NOR_SPIFI_Allow2bitMode()</code>	Specifies if the physical layer is permitted to exchange data via two data lines.
<code>FS_NOR_SPIFI_Allow4bitMode()</code>	Specifies if the physical layer is permitted to exchange data via four data lines.
<code>FS_NOR_SPIFI_AllowDTRMode()</code>	Specifies if the physical layer is permitted to exchange data on both clock edges.
<code>FS_NOR_SPIFI_AllowOctalMode()</code>	Specifies if the physical layer is permitted to exchange all the data via eight data lines (octal mode).
<code>FS_NOR_SPIFI_SetDeviceList()</code>	Configures the type of handled serial NOR flash devices.
<code>FS_NOR_SPIFI_SetDeviceParaList()</code>	Configures parameters of serial NOR flash devices.
<code>FS_NOR_SPIFI_SetHWType()</code>	Configures the HW access routines.
<code>FS_NOR_SPIFI_SetSectorSize()</code>	Configures the size of the physical sector to be used by the driver.

6.4.4.6.2.1 FS_NOR_SPIFI_Allow2bitMode()

Description

Specifies if the physical layer is permitted to exchange data via two data lines.

Prototype

```
void FS_NOR_SPIFI_Allow2bitMode(U8 Unit,  
                                U8 OnOff);
```

Parameters

Parameter	Description
<code>Unit</code>	Index of the physical layer (0-based).
<code>OnOff</code>	Activation status of the option. <ul style="list-style-type: none">• 0 Disable the option.• 1 Enable the option.

Additional information

This function is optional. By default the data is exchanged via one data line (standard SPI). The data transfer via two data lines is used only if this type of data transfer is supported by the serial NOR flash device. In dual mode two bits of data are transferred with each clock period which helps improve the performance. If the serial NOR flash device does not support the dual mode then the data is transferred in standard mode (one data bit per clock period).

The application is permitted to call this function only at the file system initialization in `FS_X_AddDevices()`.

6.4.4.6.2.2 FS_NOR_SPIFI_Allow4bitMode()

Description

Specifies if the physical layer is permitted to exchange data via four data lines.

Prototype

```
void FS_NOR_SPIFI_Allow4bitMode(U8 Unit,
                                U8 OnOff);
```

Parameters

Parameter	Description
<code>Unit</code>	Index of the physical layer (0-based).
<code>OnOff</code>	Activation status of the option. <ul style="list-style-type: none"> • 0 Disable the option. • 1 Enable the option.

Additional information

This function is optional. By default the data is exchanged via one data line (standard SPI). The data transfer via four data lines is used only if this type of data transfer is supported by the serial NOR flash device. In quad mode four bits of data are transferred on each clock period which helps improve the performance. If the serial NOR flash device does not support the quad mode then the data is transferred in dual mode if enabled and supported or in standard mode (one bit per clock period).

The application is permitted to call this function only at the file system initialization in `FS_X_AddDevices()`.

6.4.4.6.2.3 FS_NOR_SPIFI_AllowDTRMode()

Description

Specifies if the physical layer is permitted to exchange data on both clock edges.

Prototype

```
void FS_NOR_SPIFI_AllowDTRMode(U8 Unit,
                               U8 OnOff);
```

Parameters

Parameter	Description
<code>Unit</code>	Index of the physical layer (0-based).
<code>OnOff</code>	Activation status of the option. <ul style="list-style-type: none"> • 0 Disable the option. • 1 Enable the option.

Additional information

This function is optional. By default the data is exchanged only on one of the clock edges (SDR mode). In DTR mode the data is transferred on each edge of the clock which helps improve the performance. The SPIFI NOR physical layer transfers the data in DTR mode only if the used serial NOR flash device supports it.

The application is permitted to call this function only at the file system initialization in `FS_X_AddDevices()`.

The DTR mode is enabled only if the configured hardware layer implements the following optional functions: `FS_NOR_HW_TYPE_SPIFI_CONTROL_EX`, `FS_NOR_HW_TYPE_SPIFI_READ_EX` and `FS_NOR_HW_TYPE_SPIFI_WRITE_EX`

6.4.4.6.2.4 FS_NOR_SPIFI_AllowOctalMode()

Description

Specifies if the physical layer is permitted to exchange all the data via eight data lines (octal mode).

Prototype

```
void FS_NOR_SPIFI_AllowOctalMode(U8 Unit,
                                  U8 OnOff);
```

Parameters

Parameter	Description
<code>Unit</code>	Index of the physical layer (0-based).
<code>OnOff</code>	Activation status of the option. <ul style="list-style-type: none"> • 0 Disable the option. • 1 Enable the option.

Additional information

This function is optional. By default the data is exchanged via one data line (standard SPI). The data transfer via eight data lines is used only if this type of data transfer is supported by the serial NOR flash device. In octal mode eight bits of data are transferred with each clock period which helps improve the performance. If the serial NOR flash device does not support the octal mode then the data is transferred in standard mode (one bit per clock period).

The application is permitted to call this function only at the file system initialization in `FS_X_AddDevices()`.

The octal mode is enabled only if the configured hardware layer implements the following optional functions: `FS_NOR_HW_TYPE_SPIFI_CONTROL_EX`, `FS_NOR_HW_TYPE_SPIFI_READ_EX` and `FS_NOR_HW_TYPE_SPIFI_WRITE_EX`

6.4.4.6.2.5 FS_NOR_SPIFI_SetDeviceList()

Description

Configures the type of handled serial NOR flash devices.

Prototype

```
void FS_NOR_SPIFI_SetDeviceList(      U8          Unit,
                                     const FS_NOR_SPI_DEVICE_LIST * pDeviceList);
```

Parameters

Parameter	Description
<code>Unit</code>	Index of the physical layer (0-based).
<code>pDeviceList</code>	List of NOR flash devices the physical layer can handle.

Additional information

This function is optional. By default the physical layer is configured to handle Micron serial NOR flash devices. Handling of serial NOR flash devices from other manufacturers has to be explicitly enabled via this function.

Permitted values for the `pDeviceList` parameter are:

Identifier	Description
<code>FS_NOR_SPI_DeviceListAdesto</code>	Enables handling of Adesto serial NOR flash devices.
<code>FS_NOR_SPI_DeviceListAll</code>	Enables handling of serial NOR flash devices from all manufacturers.
<code>FS_NOR_SPI_DeviceListCypress</code>	Enables handling of Cypress serial NOR flash devices.
<code>FS_NOR_SPI_DeviceListDefault</code>	Enables handling of Micron and of SFDP compatible serial NOR flash devices.
<code>FS_NOR_SPI_DeviceListEon</code>	Enables handling of Eon serial NOR flash devices.
<code>FS_NOR_SPI_DeviceListGigaDevice</code>	Enables handling of GigaDevice serial NOR flash devices.
<code>FS_NOR_SPI_DeviceListISSI</code>	Enables handling of ISSI serial NOR flash devices.
<code>FS_NOR_SPI_DeviceListMacronix</code>	Enables handling of Macronix serial NOR flash devices.
<code>FS_NOR_SPI_DeviceListMacronixOctal</code>	Enables handling of Macronix serial NOR flash devices working in octal mode.
<code>FS_NOR_SPI_DeviceList_Micron</code>	Enables handling of Micron serial NOR flash devices.
<code>FS_NOR_SPI_DeviceList_Micron_x</code>	Enables handling of Micron serial NOR flash devices in single and dual chip setups.
<code>FS_NOR_SPI_DeviceList_Micron_x2</code>	Enables handling of Micron serial NOR flash devices in dual chip setups.
<code>FS_NOR_SPI_DeviceListMicrochip</code>	Enables handling of Microchip serial NOR flash devices.
<code>FS_NOR_SPI_DeviceListSpansion</code>	Enables handling of Spansion serial NOR flash devices.
<code>FS_NOR_SPI_DeviceListSTM</code>	Enables handling of STMicroelectronics serial NOR flash devices.

Identifier	Description
FS_NOR_SPI_DeviceListWinbond	Enables handling of Winbond serial NOR flash devices.

The application can save ROM space by setting `FS_NOR_DEVICE_LIST_DEFAULT` to `NULL` at compile time and by calling at runtime `FS_NOR_SPIFI_SetDeviceList()` with the actual list of serial NOR flash devices that have to be handled.

The application is permitted to call this function only at the file system initialization in `FS_X_AddDevices()`.

6.4.4.6.2.6 FS_NOR_SPIFI_SetDeviceParaList()

Description

Configures parameters of serial NOR flash devices.

Prototype

```
void FS_NOR_SPIFI_SetDeviceParaList
(
    U8 Unit,
    const FS_NOR_SPI_DEVICE_PARA_LIST * pDeviceParaList);
```

Parameters

Parameter	Description
Unit	Index of the physical layer (0-based).
pDeviceParaList	List of device parameters.

Additional information

This function is optional. This function can be used to enable handling for vendor specific features of serial NOR flash device such as error handling and data protection. By default, the parameters of the used serial NOR flash device are determined by evaluating the SFDP tables stored in it. However, the information about the commands that can be used to write the data via two and four data lines is not stored to this parameters. `FS_NOR_SFDP_SetDeviceParaList()` can be used to specify this information. The parameters are matched by comparing the first byte (manufacturer id) and the third byte (device id) of the information returned by the READ ID (0x9F) function with the MfgId and Id members of the `FS_NOR_SPI_DEVICE_PARA` structure.

The application is permitted to call this function only at the file system initialization in `FS_X_AddDevices()`.

6.4.4.6.2.7 FS_NOR_SPIFI_SetHWType()

Description

Configures the HW access routines.

Prototype

```
void FS_NOR_SPIFI_SetHWType(          U8          Unit,  
                               const FS_NOR_HW_TYPE_SPIFI * pHWType);
```

Parameters

Parameter	Description
Unit	Index of the physical layer.
pHWType	Hardware layer to be used for data exchanged.

Additional information

It is mandatory to call this function during the file system initialization in `FS_X_AddDe-`
`vices()` once for each instance of a physical layer.

6.4.4.6.2.8 FS_NOR_SPIFI_SetSectorSize()

Description

Configures the size of the physical sector to be used by the driver.

Prototype

```
void FS_NOR_SPIFI_SetSectorSize(U8 Unit,
                                U32 BytesPerSector);
```

Parameters

Parameter	Description
<code>Unit</code>	Index of the physical layer (0-based).
<code>BytesPerSector</code>	Sector size to be used.

Additional information

Typically, a serial NOR flash device supports erase commands that can be used to erase sectors of different sizes (4 KB, 32 KB, etc.) For performance reasons the physical layer chooses always the erase command corresponding to the largest physical sector. This function can be used to request the physical layer to use a different (smaller) physical sector size. The mount operation fails if the serial NOR flash device does not support the specified physical sector size.

The application is permitted to call this function only at the file system initialization in `FS_X_AddDevices()`.

6.4.4.6.3 Additional functions

The API functions listed in the following table can be used by the application to operate directly with the SPIFI physical layer. These functions can be called only after the file system configuration is completed.

Function	Description
<code>FS_NOR_SPIFI_ExecCmd()</code>	Sends command sequences to NOR flash device.

6.4.4.6.3.1 FS_NOR_SPIFI_ExecCmd()

Description

Sends command sequences to NOR flash device.

Prototype

```
int FS_NOR_SPIFI_ExecCmd(      U8      Unit,
                             const U8  * pCmd,
                             unsigned  NumBytes);
```

Parameters

Parameter	Description
Unit	Index of the physical layer (0-based).
pCmd	List of command codes. Must be different than NULL.
NumBytes	Number of command codes. Must be different than 0.

Return value

= 0 OK, command sequence sent successfully.
 ≠ 0 Error code that indicates the failure reason.

Additional information

This function is optional. It can be used to send one or more single byte commands to a NOR flash device. Each command code has to be specified as a single byte in `pCmd`. The specified commands are executed sequentially in separate SPI transactions beginning with `pCmd[0]`. All the commands are sent in single SPI mode.

Example

```
#include "FS.h"

void SampleNOR_SPIFIExecCmd(void) {
    U8 abCmd[2];

    //
    // Execute a software reset of the NOR flash device.
    //
    abCmd[0] = 0x66;
    abCmd[1] = 0x99;
    FS_NOR_SPIFI_ExecCmd(0, abCmd, sizeof(abCmd));
}
```

6.4.4.7 ST M25 physical layer

This physical layer supports legacy serial NOR flash devices.

6.4.4.7.1 Compile time configuration

The ST M25 physical layer can optionally be configured at compile time. Typically, this step can be omitted because reasonable default values are provided that work with most of the applications. The following table provides a summary of the configuration defines supported by this physical layer.

Define	Default value	Type	Description
<code>FS_NOR_MAX_NUM_DEVICES</code>	0	N	Maximum number of device parameters that the user is allowed to define.
<code>FS_NOR_TIMEOUT_PAGE_WRITE</code>	5	N	Timeout in milliseconds for the page program operation.
<code>FS_NOR_TIMEOUT_SECTOR_ERASE</code>	3000	N	Timeout in milliseconds for the sector erase operation.

6.4.4.7.1.1 FS_NOR_MAX_NUM_DEVICES

`FS_NOR_MAX_NUM_DEVICES` specifies the maximum number of user-defined device parameters. This configuration define is used together with `FS_NOR_SPI_AddDevice()`

6.4.4.7.1.2 FS_NOR_TIMEOUT_PAGE_WRITE

`FS_NOR_TIMEOUT_PAGE_WRITE` specifies the maximum number of milliseconds the physical layer has to wait for a write operation to complete. The completion of the write operation is determined by evaluating the value returned by the serial NOR flash device to a status request.

6.4.4.7.1.3 FS_NOR_TIMEOUT_SECTOR_ERASE

`FS_NOR_TIMEOUT_SECTOR_ERASE` specifies the maximum number of milliseconds the physical layer has to wait for a physical sector erase operation to complete. The completion of the erase operation is determined by evaluating the value returned by the serial NOR flash device to a status request.

6.4.4.7.2 Runtime configuration

The API functions listed in the following table can be used by the application to configure the behavior of the ST M25 physical layer. The application can call them only at the file system initialization in `FS_X_AddDevices()`.

Function	Description
<code>FS_NOR_SPI_AddDevice()</code>	Specifies parameters for a NOR flash device that has to be supported.
<code>FS_NOR_SPI_Configure()</code>	Configures the parameters of the NOR flash device.
<code>FS_NOR_SPI_SetHWType()</code>	Configures the HW access routines.
<code>FS_NOR_SPI_SetPageSize()</code>	Specifies the number of bytes in page.

6.4.4.7.2.1 FS_NOR_SPI_AddDevice()

Description

Specifies parameters for a NOR flash device that has to be supported.

Prototype

```
void FS_NOR_SPI_AddDevice(const FS_NOR_SPI_DEVICE_PARA * pDevicePara);
```

Parameters

Parameter	Description
<code>pDevicePara</code>	Device parameters.

Additional information

This function is optional. It allows an application to define the parameters of a NOR flash device that is not yet supported by the physical layer. The maximum number of NOR flash devices that can be added to the list can be specified via `FS_NOR_MAX_NUM_DEVICES` define. By default this feature is disabled, that is `FS_NOR_MAX_NUM_DEVICES` is set to 0. The data pointed to by `pDevicePara` should remain valid until `FS_DeInit()` is called, because the function saves internally only the pointer value.

This function is available only when the file system is compiled with `FS_NOR_MAX_NUM_DEVICES` set to a value larger than 0.

6.4.4.7.2.2 FS_NOR_SPI_Configure()

Description

Configures the parameters of the NOR flash device.

Prototype

```
void FS_NOR_SPI_Configure(U8 Unit,
                        U32 SectorSize,
                        U32 NumSectors);
```

Parameters

Parameter	Description
Unit	Index of the physical layer (0-based).
SectorSize	The size of a physical sector in bytes.
NumSectors	The number of physical sectors available.

Additional information

This function is optional. By default the physical layer identifies the parameters of the NOR flash device automatically using the information returned by the READ ID (0x9F) command. This method does not work for some older ST M25 NOR flash devices. In this case the application can use FS_NOR_SPI_Configure() to specify the parameters of the NOR flash device. SPI NOR (M25 series) flash devices have uniform sectors, which means only one sector size is used for the entire device.

The capacity of the serial NOR flash device is determined as follows:

Value of 3rd byte	Capacity in Mbits
0x11	1
0x12	2
0x13	4
0x14	8
0x15	16
0x16	32
0x17	64
0x18	128

The application required to call FS_NOR_SPI_Configure(), only if the serial NOR flash device does not identify itself with one of the values specified in the table above.

SectorSize must be set to the size of the size of the storage area erased via the Block Erase (0xD8) command. NumSectors is the device capacity in bytes divided by SectorSize.

The application is permitted to call this function only at the file system initialization in FS_X_AddDevices().

Example

```
#include "FS.h"

#define ALLOC_SIZE      0x4000      // Size defined in bytes

static U32 _aMemBlock[ALLOC_SIZE / 4]; // Memory pool used for
                                        // semi-dynamic allocation.

/*****
 *
 *     FS_X_AddDevices
 *
 *****/
```

```
* Function description
* This function is called by the FS during FS_Init().
*/
void FS_X_AddDevices(void) {
    //
    // Give the file system memory to work with.
    //
    FS_AssignMemory(&_aMemBlock[0], sizeof(_aMemBlock));
    //
    // Add the NOR driver driver.
    //
    FS_AddDevice(&FS_NOR_Driver);
    //
    // Configure manually a 16 Mbit SPI NOR flash.
    //
    FS_NOR_SetPhyType(0, &FS_NOR_PHY_ST_M25);
    FS_NOR_SPI_Configure(0, 0x10000, 32);
    FS_NOR_Configure(0, 0, 0, 0x10000 * 32);
}
```

6.4.4.7.2.3 FS_NOR_SPI_SetHWType()

Description

Configures the HW access routines.

Prototype

```
void FS_NOR_SPI_SetHWType(      U8          Unit,  
                             const FS_NOR_HW_TYPE_SPI * pHWType);
```

Parameters

Parameter	Description
Unit	Index of the physical layer (0-based).
pHWType	Hardware access routines. Cannot be NULL.

Additional information

This function is mandatory and it has to be called once for each instance of the physical layer.

6.4.4.7.2.4 FS_NOR_SPI_SetPageSize()

Description

Specifies the number of bytes in page.

Prototype

```
void FS_NOR_SPI_SetPageSize(U8 Unit,  
                             U16 BytesPerPage);
```

Parameters

Parameter	Description
Unit	Index of the physical layer (0-based).
BytesPerPage	Number of bytes in a page.

Additional information

This function is optional. A page is the largest amount of bytes that can be written at once to a serial NOR flash device. By default the physical layer uses a page size of 256 bytes a value that is supported by the majority of serial NOR flash devices.

The size of a page cannot be automatically detected by the physical layer at runtime. Therefore, if the used serial NOR flash device has a page size different than 256 bytes, `FS_NOR_SPI_SetPageSize()` has to be used to configure the page size to the actual value. The write operation fails if the page size used by the physical layer is larger than the page size used by the serial NOR flash device. The write operation works if the application specifies a smaller page size than the actual page size of the serial NOR flash device but the write performance will be worst.

[BytesPerPage](#) has to be a power of 2 value.

6.4.4.7.2.5 FS_NOR_SPI_DEVICE_PARA

Description

Defines the parameters of a serial NOR flash device.

Type definition

```
typedef struct {
    U8    Id;
    U8    ldBytesPerSector;
    U8    ldBytesPerPage;
    U8    NumBytesAddr;
    U32   NumSectors;
    U8    Flags;
    U8    MfgId;
    U8    CmdWrite112;
    U8    CmdWrite122;
    U8    CmdWrite114;
    U8    CmdWrite144;
} FS_NOR_SPI_DEVICE_PARA;
```

Structure members

Member	Description
Id	Value to identify the serial NOR flash device. This is the 3rd byte in the response to READ ID (0x9F) command.
ldBytesPerSector	Number of bytes in a physical sector as power of 2 exponent.
ldBytesPerPage	Number of bytes in a page as a power of 2 exponent.
NumBytesAddr	Number of address bytes. 4 for NOR flash devices with a capacity larger than 128 Mbit (16 Mbyte).
NumSectors	Total number of physical sectors in the device.
Flags	Additional functionality supported by device that requires special processing.
MfgId	Id of device manufacturer. This is the 1st byte in the response to READ ID (0x9F) command.
CmdWrite112	Code of the command used to write the data to NOR flash via 2 data lines. The command itself and the address are transferred via data 1 line.
CmdWrite122	Code of the command used to write the data to NOR flash via 2 data lines. The command itself is transferred via data 1 line while the address via 2 data lines.
CmdWrite114	Code of the command used to write the data to NOR flash via 4 data lines. The command itself and the address are transferred via data 1 line.
CmdWrite144	Code of the command used to write the data to NOR flash via 4 data lines. The command itself is transferred via data 1 line while the address via 4 data lines.

Additional information

[Flags](#) is an bitwise-or combination of *Device operation flags* on page 882.

6.4.4.7.2.6 Device operation flags

Description

Values to be used for the Flags member of FS_NOR_SPI_DEVICE_PARA

Definition

```
#define FS_NOR_SPI_DEVICE_FLAG_ERROR_STATUS    (1u << 0)
#define FS_NOR_SPI_DEVICE_FLAG_WEL_ADDR_MODE  (1u << 1)
```

Symbols

Definition	Description
FS_NOR_SPI_DEVICE_FLAG_ERROR_STATUS	The device reports errors via Flag Status Register.
FS_NOR_SPI_DEVICE_FLAG_WEL_ADDR_MODE	The write enable latch has to be set before changing the address mode.

6.4.4.7.3 Additional functions

The API functions listed in the following table can be used by the application to operate directly with the ST M25 physical layer.

Function	Description
<code>FS_NOR_SPI_ReadDeviceId()</code>	Reads device identification information from NOR flash device.

6.4.4.7.3.1 FS_NOR_SPI_ReadDeviceId()

Description

Reads device identification information from NOR flash device.

Prototype

```
void FS_NOR_SPI_ReadDeviceId(U8          Unit,  
                             U8          * pId,  
                             unsigned    NumBytes);
```

Parameters

Parameter	Description
<code>Unit</code>	Index of the physical layer (0-based).
<code>pId</code>	<code>out</code> Information read from NOR flash.
<code>NumBytes</code>	Number of bytes to read from NOR flash.

Additional information

The data returned by this function is the response to the READ ID (0x9F) command.

6.4.4.8 Physical layer API

The physical layers that come with emFile provide support most of the popular NOR flash device and target MCU types. Therefore, there is typically no need to modify any of the provided NOR physical layers. Typically, only the NOR hardware layer has to be adapted to a specific target hardware. However, when none of the provided NOR physical layers are compatible with the target hardware a new NOR physical layer implementation is required. This section provides information about the API of the NOR physical layer that helps to create a new physical layer from scratch or to modify an existing one.

The API of the physical layer is implemented as a structure of type `FS_NOR_PHY_TYPE` that contains pointers to functions. The following sections describe these functions in detail together with the data structure passed to these functions as parameters.

6.4.4.8.1 FS_NOR_PHY_TYPE

Description

NOR physical layer API.

Type definition

```
typedef struct {
    FS_NOR_PHY_TYPE_WRITE_OFF      * pfWriteOff;
    FS_NOR_PHY_TYPE_READ_OFF      * pfReadOff;
    FS_NOR_PHY_TYPE_ERASE_SECTOR  * pfEraseSector;
    FS_NOR_PHY_TYPE_GET_SECTOR_INFO * pfGetSectorInfo;
    FS_NOR_PHY_TYPE_GET_NUM_SECTORS * pfGetNumSectors;
    FS_NOR_PHY_TYPE_CONFIGURE     * pfConfigure;
    FS_NOR_PHY_TYPE_ON_SELECT_PHY * pfOnSelectPhy;
    FS_NOR_PHY_TYPE_DE_INIT       * pfDeInit;
    FS_NOR_PHY_TYPE_IS_SECTOR_BLANK * pfIsSectorBlank;
    FS_NOR_PHY_TYPE_INIT          * pfInit;
} FS_NOR_PHY_TYPE;
```

Structure members

Member	Description
pfWriteOff	Writes data to the NOR flash device.
pfReadOff	Reads data from the NOR flash device.
pfEraseSector	Erases a NOR physical sector.
pfGetSectorInfo	Returns information about a NOR physical sector.
pfGetNumSectors	Returns the number of NOR physical sectors.
pfConfigure	Configures an instance of the NOR physical layer.
pfOnSelectPhy	Prepares the access to the NOR flash device.
pfDeInit	Frees the resources allocated by the NOR physical layer instance.
pfIsSectorBlank	Verifies if a NOR physical sector is blank.
pfInit	Initializes the instance of the NOR physical layer.

6.4.4.8.2 FS_NOR_PHY_TYPE_WRITE_OFF

Description

Writes data to the NOR flash device.

Type definition

```
typedef int FS_NOR_PHY_TYPE_WRITE_OFF(
    U8      Unit,
    U32     Off,
    const void * pData,
    U32     NumBytes);
```

Parameters

Parameter	Description
<code>Unit</code>	Index of the physical layer instance (0-based)
<code>Off</code>	Byte offset to write to.
<code>pData</code>	in Data to be written to NOR flash device.
<code>NumBytes</code>	Number of bytes to be written.

Return value

= 0 OK, data written.
 ≠ 0 An error occurred.

Additional information

This function is a member of the NOR physical layer API. It is mandatory to be implemented by all the NOR physical layers. The NOR driver calls this function when it writes data to the NOR flash device. It is guaranteed that the NOR driver tries to modify memory regions of the NOR flash device that are erased. This means that the function does not have to check if the memory region it has to modify are already erased. `FS_NOR_PHY_TYPE_WRITE_OFF` has to be able to handle write requests that stretch over multiple physical sectors.

`Off` specifies a number of bytes relative to the `StartAddr` value specified in the call to `FS_NOR_PHY_TYPE_CONFIGURE`.

6.4.4.8.3 FS_NOR_PHY_TYPE_READ_OFF

Description

Reads data from the NOR flash device.

Type definition

```
typedef int FS_NOR_PHY_TYPE_READ_OFF(U8      Unit,
                                     void *  pData,
                                     U32     Off,
                                     U32     NumBytes);
```

Parameters

Parameter	Description
<code>Unit</code>	Index of the physical layer instance (0-based)
<code>pData</code>	<code>out</code> Data read from NOR flash device.
<code>Off</code>	Byte offset to read from.
<code>NumBytes</code>	Number of bytes to be read.

Return value

= 0 OK, data read.
 ≠ 0 An error occurred.

Additional information

This function is a member of the NOR physical layer API. It is mandatory to be implemented by all the NOR physical layers. The NOR driver calls this function when it reads data from the NOR flash device. `FS_NOR_PHY_TYPE_READ_OFF` has to be able to handle read request that stretch over multiple physical sectors.

`Off` specifies a number of bytes relative to the `StartAddr` value specified in the call to `FS_NOR_PHY_TYPE_CONFIGURE`.

6.4.4.8.4 FS_NOR_PHY_TYPE_ERASE_SECTOR

Description

Erases a NOR physical sector.

Type definition

```
typedef int FS_NOR_PHY_TYPE_ERASE_SECTOR(U8          Unit,
                                         unsigned int SectorIndex);
```

Parameters

Parameter	Description
<code>Unit</code>	Index of the physical layer instance (0-based)
<code>SectorIndex</code>	Index of the NOR physical sector to be erased.

Return value

= 0 OK, physical sector is not blank.
 ≠ 0 An error occurred.

Additional information

This function is a member of the NOR physical layer API. It is mandatory to be implemented by all the NOR physical layers. The NOR driver calls this function when it erases a physical sector NOR flash device. The erase operation must set to 1 all the bits in the specified physical sector.

`SectorIndex` is relative to `StartAddr` value specified in the call to `FS_NOR_PHY_TYPE_CONFIGURE`. The physical sector located at `StartAddr` has the index 0.

6.4.4.8.5 FS_NOR_PHY_TYPE_GET_SECTOR_INFO

Description

Returns information about a NOR physical sector.

Type definition

```
typedef void FS_NOR_PHY_TYPE_GET_SECTOR_INFO(U8          Unit,
                                              unsigned int SectorIndex,
                                              U32         * pOff,
                                              U32         * pNumBytes);
```

Parameters

Parameter	Description
<code>Unit</code>	Index of the physical layer instance (0-based)
<code>SectorIndex</code>	Index of the NOR physical sector to be queried.
<code>pOff</code>	out Byte offset of the NOR physical sector. Can be <code>NULL</code> .
<code>pNumBytes</code>	out Number of bytes in the NOR physical sector. Can be <code>NULL</code> .

Additional information

This function is a member of the NOR physical layer API. It is mandatory to be implemented by all the NOR physical layers. The NOR driver calls this function when it tries to determine the position and the size of a physical sector.

The value returned via `pOff` and `SectorIndex` are relative to `StartAddr` value specified in the call to `FS_NOR_PHY_TYPE_CONFIGURE`.

An error can be reported by setting `*pNumBytes` to 0 or by setting

- `pOff` to `0xFFFFFFFF`.

6.4.4.8.6 FS_NOR_PHY_TYPE_GET_NUM_SECTORS

Description

Returns the number of NOR physical sectors.

Type definition

```
typedef int FS_NOR_PHY_TYPE_GET_NUM_SECTORS(U8 Unit);
```

Parameters

Parameter	Description
Unit	Index of the physical layer instance (0-based)

Return value

≠ 0 OK, the number of NOR physical sectors.
= 0 An error occurred.

Additional information

This function is a member of the NOR physical layer API. It is mandatory to be implemented by all the NOR physical layers. The value returned by this function is the number of physical sectors located in the memory region specified by StartAddr and NumBytes values specified in the call to FS_NOR_PHY_TYPE_CONFIGURE.

6.4.4.8.7 FS_NOR_PHY_TYPE_CONFIGURE

Description

Configures an instance of the NOR physical layer.

Type definition

```
typedef void FS_NOR_PHY_TYPE_CONFIGURE(U8 Unit,
                                         U32 BaseAddr,
                                         U32 StartAddr,
                                         U32 NumBytes);
```

Parameters

Parameter	Description
<code>Unit</code>	Index of the physical layer instance (0-based)
<code>BaseAddr</code>	Address in system memory where the first byte of the NOR flash device is mapped.
<code>StartAddr</code>	Address of the first byte of the NOR flash device to be used for data storage.
<code>NumBytes</code>	Number of bytes to be used for data storage.

Additional information

This function is a member of the NOR physical layer API. It is mandatory to be implemented by all the NOR physical layers. `FS_NOR_PHY_TYPE_CONFIGURE` is called by the NOR driver during the initialization of the file system.

For more information about the parameters refer to `FS_NOR_Configure()` and `FS_NOR_B-M_Configure()`.

6.4.4.8.8 FS_NOR_PHY_TYPE_ON_SELECT_PHY

Description

Prepares the access to the NOR flash device.

Type definition

```
typedef void FS_NOR_PHY_TYPE_ON_SELECT_PHY(U8 Unit);
```

Parameters

Parameter	Description
<code>Unit</code>	Index of the physical layer instance (0-based)

Additional information

This function is a member of the NOR physical layer API. It is mandatory to be implemented by all the NOR physical layer. The NOR driver calls this function during the file system initialization when a NOR physical layer is assigned to a driver instance. Typically, `FS_NOR_PHY_TYPE_ON_SELECT_PHY` allocates the memory requires for the instance of the NOR physical layer and set up everything requires for the access to NOR flash device.

6.4.4.8.9 FS_NOR_PHY_TYPE_DE_INIT

Description

Frees the resources allocated by the NOR physical layer instance.

Type definition

```
typedef void FS_NOR_PHY_TYPE_DE_INIT(U8 Unit);
```

Parameters

Parameter	Description
<code>Unit</code>	Index of the physical layer instance (0-based)

Additional information

This function is a member of the NOR physical layer API. It is mandatory to be implemented only by the NOR physical layers that allocate dynamic memory. `FS_NOR_PHY_TYPE_DE_INIT` is called by the NOR driver at the file system deinitialization when the application calls `FS_DeInit()`. It has to free any dynamic memory allocated for the instance of specified the NOR physical layer.

6.4.4.8.10 FS_NOR_PHY_TYPE_IS_SECTOR_BLANK

Description

Verifies if a NOR physical sector is blank.

Type definition

```
typedef int FS_NOR_PHY_TYPE_IS_SECTOR_BLANK(U8          Unit,
                                             unsigned int SectorIndex);
```

Parameters

Parameter	Description
<code>Unit</code>	Index of the physical layer instance (0-based)
<code>SectorIndex</code>	Index of the NOR physical sector to be checked.

Return value

≠ 0 NOR physical sector is blank.
 = 0 NOR physical sector is not blank.

Additional information

This function is a member of the NOR physical layer API. The implementation of this function is optional. By default the NOR driver checks if a physical sector is blank by reading the entire contents of the physical sector and by checking that all bits are set to 1. If the hardware provides a faster method to check if a physical sector is blank then this function can be implemented to use this method for increasing the write performance. If the operation of the NOR driver has to be fail-safe then `FS_NOR_PHY_TYPE_IS_SECTOR_BLANK` must be able to detect an interrupted erase operation and in that case return that the physical sector is not blank even when all the bits in the physical sector read as 1.

6.4.4.8.11 FS_NOR_PHY_TYPE_INIT

Description

Initializes the instance of the NOR physical layer.

Type definition

```
typedef int FS_NOR_PHY_TYPE_INIT(U8 Unit);
```

Parameters

Parameter	Description
<code>Unit</code>	Index of the physical layer instance (0-based)

Return value

= 0 OK, physical layer initialized.
≠ 0 An error occurred.

Additional information

This function is a member of the NOR physical layer API. The implementation of this function is optional. If implemented, `FS_NOR_PHY_TYPE_INIT` is called by the NOR driver before the first access to the NOR flash device to identify the device, read the device parameters, etc.

6.4.4.9 Resource usage

This section describes the ROM and RAM usage of the NOR physical layers.

6.4.4.9.1 ROM usage

The ROM usage depends on the compiler options, the compiler version, and the used CPU. The memory requirements of the NOR physical layers were measured as described in the section *Test procedure* on page 1283.

The following table lists the ROM usage of all the available NOR physical layers.

Name	ROM usage(Kbytes)
CFI 1x16	3.0
CFI 2x16	3.1
DSPI	6.2
SFDP	4.0
SPIFI	3.8
ST M25	1.8

6.4.4.9.2 Static RAM usage

Static RAM usage is the amount of RAM required by the driver for static variables inside the driver. The number of bytes can be seen in a compiler list file. The next table lists the static RAM usage of all the available NOR physical layers.

Name	RAM usage (bytes)
CFI 1x16	20
CFI 2x16	20
DSPI	20
SFDP	20
SPIFI	20
ST M25	20

6.4.4.9.3 Dynamic RAM usage

Dynamic RAM usage is the amount of RAM allocated by the physical layer at runtime. The amount of RAM required depends on the compile time and runtime configuration. The following table lists the the dynamic RAM usage of the available NOR physical layers.

Name	RAM usage (bytes)
CFI 1x16	64
CFI 2x16	64
DSPI	0
SFDP	116
SPIFI	120
ST M25	38

6.4.5 NOR hardware layer

6.4.5.1 General information

The NOR hardware layer provides functionality for accessing a NOR flash device via the target hardware such as external memory controller, GPIO, SPI, etc. The functions of the NOR hardware layer are called by the NOR physical layer to exchange commands and data with a NOR flash device. These functions are hardware dependent and therefore they have to be implemented in the application. emFile comes with template hardware layers and sample implementations for popular evaluation boards that can be used as starting point for implementing new hardware layers. The relevant files are located in the `/Sample/FS/Driver/NOR` folder of the emFile shipment.

The functions of the NOR hardware layer are organized in a function table implemented as a C structure. Different hardware layer types are provided to support different ways of interfacing a NOR flash device. The type of hardware layer an application has to use depends on the type NOR physical layer configured. The following table shows what hardware layer is required by each physical layer.

NOR hardware layer	NOR physical layer
FS_NOR_HW_TYPE_SPI	FS_NOR_PHY_DSPI FS_NOR_PHY_SFDP FS_NOR_PHY_ST_M25
FS_NOR_HW_TYPE_SPIFI	FS_NOR_PHY_SPIFI

6.4.5.2 Hardware layer API - FS_NOR_HW_TYPE_SPI

This hardware layer supports serial NOR flash devices that are interfaced via single or extended SPI. It is able to transfer the data via one, two or four data lines. The functions of this hardware layer are grouped in a structure of type `FS_NOR_HW_TYPE_SPI`. The following sections describe these functions in detail.

6.4.5.2.1 FS_NOR_HW_TYPE_SPI

Description

Hardware layer for serial NOR flash devices.

Type definition

```
typedef struct {
    FS_NOR_HW_TYPE_SPI_INIT          * pfInit;
    FS_NOR_HW_TYPE_SPI_ENABLE_CS    * pfEnableCS;
    FS_NOR_HW_TYPE_SPI_DISABLE_CS   * pfDisableCS;
    FS_NOR_HW_TYPE_SPI_READ         * pfRead;
    FS_NOR_HW_TYPE_SPI_WRITE        * pfWrite;
    FS_NOR_HW_TYPE_SPI_READ_X2      * pfRead_x2;
    FS_NOR_HW_TYPE_SPI_WRITE_X2     * pfWrite_x2;
    FS_NOR_HW_TYPE_SPI_READ_X4     * pfRead_x4;
    FS_NOR_HW_TYPE_SPI_WRITE_X4    * pfWrite_x4;
    FS_NOR_HW_TYPE_SPI_DELAY        * pfDelay;
    FS_NOR_HW_TYPE_SPI_LOCK         * pfLock;
    FS_NOR_HW_TYPE_SPI_UNLOCK       * pfUnlock;
    FS_NOR_HW_TYPE_SPI_READ_EX      * pfReadEx;
    FS_NOR_HW_TYPE_SPI_WRITE_EX     * pfWriteEx;
} FS_NOR_HW_TYPE_SPI;
```

Structure members

Member	Description
pfInit	Initializes the SPI hardware.
pfEnableCS	Enables the serial NOR flash device.
pfDisableCS	Disables the serial NOR flash device.
pfRead	Transfers data from serial NOR flash device to MCU via 1 data line.
pfWrite	Transfers data from MCU to serial NOR flash device via 1 data line.
pfRead_x2	Transfers data from serial NOR flash device to MCU via 2 data lines.
pfWrite_x2	Transfers data from MCU to serial NOR flash device via 2 data lines.
pfRead_x4	Transfers data from serial NOR flash device to MCU via 4 data lines.
pfWrite_x4	Transfers data from MCU to serial NOR flash device via 4 data lines.
pfDelay	Blocks the execution for the specified time.
pfLock	Requests exclusive access to SPI bus.
pfUnlock	Releases the exclusive access to SPI bus.
pfReadEx	Transfers data from serial NOR flash device to MCU.
pfWriteEx	Transfers data from MCU to serial NOR flash device.

6.4.5.2.2 FS_NOR_HW_TYPE_SPI_INIT

Description

Initializes the SPI hardware.

Type definition

```
typedef int FS_NOR_HW_TYPE_SPI_INIT(U8 Unit);
```

Parameters

Parameter	Description
<code>Unit</code>	Index of the hardware layer (0-based).

Return value

> 0 OK, frequency of the SPI clock in kHz.
= 0 An error occurred.

Additional information

This function is a member of the SPI NOR hardware layer API. It has to be implemented by all the hardware layers.

This function is called by the NOR physical layer once and before any other function of the hardware layer each time the file system mounts the serial NOR flash.

6.4.5.2.3 FS_NOR_HW_TYPE_SPI_ENABLE_CS

Description

Enables the serial NOR flash device.

Type definition

```
typedef void FS_NOR_HW_TYPE_SPI_ENABLE_CS(U8 Unit);
```

Parameters

Parameter	Description
Unit	Index of the hardware layer (0-based).

Additional information

This function is a member of the SPI NOR hardware layer API. It has to be implemented by all the hardware layers.

The Chip Select (CS) signal is used to address a specific serial NOR flash device connected via SPI. Enabling is equal to setting the CS signal to a logic low level.

6.4.5.2.4 FS_NOR_HW_TYPE_SPI_DISABLE_CS

Description

Disables the serial NOR flash device.

Type definition

```
typedef void FS_NOR_HW_TYPE_SPI_DISABLE_CS(U8 Unit);
```

Parameters

Parameter	Description
<code>Unit</code>	Index of the hardware layer (0-based).

Additional information

This function is a member of the SPI NOR hardware layer API. It has to be implemented by all the hardware layers.

The Chip Select (CS) signal is used to address a specific serial NOR flash device connected via SPI. Disabling is equal to setting the CS signal to a logic high level.

6.4.5.2.5 FS_NOR_HW_TYPE_SPI_READ

Description

Transfers data from serial NOR flash device to MCU via 1 data line.

Type definition

```
typedef void FS_NOR_HW_TYPE_SPI_READ(U8    Unit,  
                                     U8 * pData,  
                                     int   NumBytes);
```

Parameters

Parameter	Description
<code>Unit</code>	Index of the hardware layer (0-based).
<code>pData</code>	<code>out</code> Data transferred from the serial NOR flash device.
<code>NumBytes</code>	Number of bytes to be transferred.

Additional information

This function is a member of the SPI NOR hardware layer API. `FS_NOR_HW_TYPE_SPI_READ` does not have to be implemented if the hardware layer provides an implementation for `FS_NOR_HW_TYPE_SPI_READ_EX`.

6.4.5.2.6 FS_NOR_HW_TYPE_SPI_WRITE

Description

Transfers data from MCU to serial NOR flash device via 1 data line.

Type definition

```
typedef void FS_NOR_HW_TYPE_SPI_WRITE(
    U8    Unit,
    const U8 * pData,
    int   NumBytes);
```

Parameters

Parameter	Description
<code>Unit</code>	Index of the hardware layer (0-based).
<code>pData</code>	in Data transferred to the serial NOR flash device.
<code>NumBytes</code>	Number of bytes to be transferred.

Additional information

This function is a member of the SPI NOR hardware layer API. `FS_NOR_HW_TYPE_SPI_WRITE` does not have to be implemented if the hardware layer provides an implementation for `FS_NOR_HW_TYPE_SPI_WRITE_EX`.

6.4.5.2.7 FS_NOR_HW_TYPE_SPI_READ_X2

Description

Transfers data from serial NOR flash device to MCU via 2 data lines.

Type definition

```
typedef void FS_NOR_HW_TYPE_SPI_READ_X2(U8    Unit,
                                         U8 *  pData,
                                         int   NumBytes);
```

Parameters

Parameter	Description
<code>Unit</code>	Index of the hardware layer (0-based).
<code>pData</code>	<code>out</code> Data transferred from the serial NOR flash device.
<code>NumBytes</code>	Number of bytes to be transferred.

Additional information

This function is a member of the SPI NOR hardware layer API. The implementation of this function is optional.

`FS_NOR_HW_TYPE_SPI_READ_X2` transfers 2 bits of data on each clock period. Typically, the data is transferred via the DataOut (DO) and DataIn (DI) signals of the serial NOR flash where the even numbered bits of a byte are sent via the DI signal while the odd-numbered bits via the DO signal.

`FS_NOR_HW_TYPE_SPI_READ_X2` is used only by the SFDP NOR physical layer.

6.4.5.2.8 FS_NOR_HW_TYPE_SPI_WRITE_X2

Description

Transfers data from MCU to serial NOR flash device via 2 data lines.

Type definition

```
typedef void FS_NOR_HW_TYPE_SPI_WRITE_X2(
    U8    Unit,
    const U8 * pData,
    int   NumBytes);
```

Parameters

Parameter	Description
<code>Unit</code>	Index of the hardware layer (0-based).
<code>pData</code>	in Data transferred to the serial NOR flash device.
<code>NumBytes</code>	Number of bytes to be transferred.

Additional information

This function is a member of the SPI NOR hardware layer API. The implementation of this function is optional.

`FS_NOR_HW_TYPE_SPI_WRITE_X2` transfers 2 bits of data on each clock period. Typically, the data is transferred via the DataOut (DO) and DataIn (DI) signals of the serial NOR flash where the even numbered bits of a byte are sent via the DI signal while the odd-numbered bits via the DO signal.

`FS_NOR_HW_TYPE_SPI_WRITE_X2` is used only by the SFDP NOR physical layer.

6.4.5.2.9 FS_NOR_HW_TYPE_SPI_READ_X4

Description

Transfers data from serial NOR flash device to MCU via 4 data lines.

Type definition

```
typedef void FS_NOR_HW_TYPE_SPI_READ_X4(U8    Unit,
                                         U8 *  pData,
                                         int   NumBytes);
```

Parameters

Parameter	Description
<code>Unit</code>	Index of the hardware layer (0-based).
<code>pData</code>	<code>out</code> Data transferred from the serial NOR flash device.
<code>NumBytes</code>	Number of bytes to be transferred.

Additional information

This function is a member of the SPI NOR hardware layer API. The implementation of this function is optional.

`FS_NOR_HW_TYPE_SPI_READ_X4` exchanges 4 bits of data on each clock period. Typically, the data is transferred via the DataOut (DO), DataIn (DI), Write Protect (WP), and Hold (H) signals of the serial NOR flash device. A byte is transferred as follows:

- bits 0 and 4 via the DI signal
- bits 1 and 5 via the DO signal
- bits 2 and 6 via the WP signal
- bits 3 and 7 via the H signal.

`FS_NOR_HW_TYPE_SPI_READ_X4` is used only by the SFDP NOR physical layer.

6.4.5.2.10 FS_NOR_HW_TYPE_SPI_WRITE_X4

Description

Transfers data from MCU to serial NOR flash device via 4 data lines.

Type definition

```
typedef void FS_NOR_HW_TYPE_SPI_WRITE_X4(
    U8    Unit,
    const U8 * pData,
    int   NumBytes);
```

Parameters

Parameter	Description
<code>Unit</code>	Index of the hardware layer (0-based).
<code>pData</code>	in Data transferred to the serial NOR flash device.
<code>NumBytes</code>	Number of bytes to be transferred.

Additional information

This function is a member of the SPI NOR hardware layer API. The implementation of this function is optional.

`FS_NOR_HW_TYPE_SPI_WRITE_X4` exchanges 4 bits of data on each clock period. Typically, the data is transferred via the DataOut (DO), DataIn (DI), Write Protect (WP), and Hold (H) signals of the serial NOR flash device. A byte is transferred as follows:

- bits 0 and 4 via the DI signal
- bits 1 and 5 via the DO signal
- bits 2 and 6 via the WP signal
- bits 3 and 7 via the H signal.

`FS_NOR_HW_TYPE_SPI_WRITE_X4` is used only by the SFDP NOR physical layer.

6.4.5.2.11 FS_NOR_HW_TYPE_SPI_DELAY

Description

Blocks the execution for the specified time.

Type definition

```
typedef int FS_NOR_HW_TYPE_SPI_DELAY(U8 Unit,
                                     U32 ms);
```

Parameters

Parameter	Description
<code>Unit</code>	Index of the hardware layer (0-based).
<code>ms</code>	Number of milliseconds to block the execution.

Return value

= 0 OK, delay executed.
 < 0 Functionality not supported.

Additional information

This function is a member of the SPI NOR hardware layer API. The implementation of this function is optional. `FS_NOR_HW_TYPE_SPI_DELAY` can block the execution for longer than the number of milliseconds specified but not less than that. Typically, the function is implemented using a delay function of the used RTOS if any. If the hardware layer chooses not to implement `FS_NOR_HW_TYPE_SPI_DELAY` then the `pfDelay` member of `FS_NOR_HW_TYPE_SPI` can be set to `NULL` or to the address of a function that returns a negative value. If the function is not implemented by the hardware layer then the NOR physical layer blocks the execution by using a software loop. The number of software loops is calculated based in the SPI clock frequency returned by `FS_NOR_HW_TYPE_SPI_INIT`.

6.4.5.2.12 FS_NOR_HW_TYPE_SPI_LOCK

Description

Requests exclusive access to SPI bus.

Type definition

```
typedef void FS_NOR_HW_TYPE_SPI_LOCK(U8 Unit);
```

Parameters

Parameter	Description
<code>Unit</code>	Index of the hardware layer (0-based).

Additional information

This function is a member of the SPI NOR hardware layer API. The implementation of this function is optional.

The NOR physical layer calls this function to indicate that it needs exclusive to access the NOR flash device via the SPI bus. It is guaranteed that the NOR physical layer does not attempt to exchange any data with the serial NOR flash device via the SPI bus before calling this function first. It is also guaranteed that `FS_NOR_HW_TYPE_SPI_LOCK` and `FS_NOR_HW_TYPE_SPI_UNLOCK` are called in pairs. Typically, this function is used for synchronizing the access to SPI bus when the SPI bus is shared between the serial NOR flash and other SPI devices.

A possible implementation would make use of an OS semaphore that is acquired in `FS_NOR_HW_TYPE_SPI_LOCK` and released in `FS_NOR_HW_TYPE_SPI_UNLOCK`.

6.4.5.2.13 FS_NOR_HW_TYPE_SPI_UNLOCK

Description

Requests exclusive access to SPI bus.

Type definition

```
typedef void FS_NOR_HW_TYPE_SPI_UNLOCK(U8 Unit);
```

Parameters

Parameter	Description
<code>Unit</code>	Index of the hardware layer (0-based).

Additional information

This function is a member of the SPI NOR hardware layer API. The implementation of this function is optional.

The NOR physical layer calls this function after it no longer needs to access the serial NOR flash device via the SPI bus. It is guaranteed that the NOR physical layer does not attempt to exchange any data with the serial NOR flash device via the SPI bus before calling `FS_NOR_HW_TYPE_SPI_LOCK`. It is also guaranteed that `FS_NOR_HW_TYPE_SPI_UNLOCK` and `FS_NOR_HW_TYPE_SPI_LOCK` are called in pairs.

`FS_NOR_HW_TYPE_SPI_UNLOCK` and `FS_NOR_HW_TYPE_SPI_LOCK` can be used to synchronize the access to the SPI bus when other devices than the serial NAND flash are connected to it. A possible implementation would make use of an OS semaphore that is acquired `FS_NOR_HW_TYPE_SPI_LOCK` and released in `FS_NOR_HW_TYPE_SPI_UNLOCK`.

6.4.5.2.14 FS_NOR_HW_TYPE_SPI_READ_EX

Description

Transfers data from serial NOR flash device to MCU.

Type definition

```
typedef int FS_NOR_HW_TYPE_SPI_READ_EX(U8    Unit,
                                       U8 * pData,
                                       U32  NumBytes,
                                       U8   BusWidth);
```

Parameters

Parameter	Description
Unit	Index of the hardware layer (0-based).
pData	out Data transferred from the serial NOR flash device.
NumBytes	Number of bytes to be transferred.
BusWidth	Number of data lines to be used for the data transfer.

Return value

= 0 OK, data transferred successfully.
 ≠ 0 An error occurred.

Additional information

This function is a member of the SPI NOR hardware layer API. `FS_NOR_HW_TYPE_SPI_READ_EX` does not have to be implemented if the hardware layer provides an implementation for `FS_NOR_HW_TYPE_SPI_READ`.

The difference between `FS_NOR_HW_TYPE_SPI_READ_EX` and `FS_NOR_HW_TYPE_SPI_READ` is that `FS_NOR_HW_TYPE_SPI_READ_EX` is able to transfer the data via a specified number of data lines and to report errors via the return value.

BusWidth permitted values are 1, 2 and 4.

6.4.5.2.15 FS_NOR_HW_TYPE_SPI_WRITE_EX

Description

Transfers data from MCU to serial NOR flash device.

Type definition

```
typedef int FS_NOR_HW_TYPE_SPI_WRITE_EX(
    U8    Unit,
    const U8 * pData,
    U32   NumBytes,
    U8    BusWidth);
```

Parameters

Parameter	Description
Unit	Index of the hardware layer (0-based).
pData	in Data transferred to the serial NOR flash device.
NumBytes	Number of bytes to be transferred.
BusWidth	Number of data lines to be used for the data transfer.

Return value

= 0 OK, data transferred successfully.
 ≠ 0 An error occurred.

Additional information

This function is a member of the SPI NOR hardware layer API. `FS_NOR_HW_TYPE_SPI_WRITE_EX` does not have to be implemented if the hardware layer provides an implementation for `FS_NOR_HW_TYPE_SPI_WRITE`.

The difference between `FS_NOR_HW_TYPE_SPI_WRITE_EX` and `FS_NOR_HW_TYPE_SPI_WRITE` is that `FS_NOR_HW_TYPE_SPI_WRITE_EX` is able to transfer the data via a specified number of data lines and to report errors via the return value.

BusWidth permitted values are 1, 2 and 4.

6.4.5.2.16 Sample implementation

The following sample implementation uses the SPI controller of an NXP K66 MCU to interface with a serial NOR flash device. This NOR hardware layer was tested on the SGER emPower board (<https://www.segger.com/evaluate-our-software/segger/empower/>)

```

/*****
*                               (c) SEGGER Microcontroller GmbH                               *
*                               The Embedded Experts                                       *
*                               www.segger.com                                           *
*****/

----- END-OF-HEADER -----

File      : FS_NOR_HW_SPI_K66_SEGGER_emPower.c
Purpose  : NOR SPI hardware layer for the SEGGER emPower board
Literature:
  [1] K66 Sub-Family Reference Manual
  [2] emPower Evaluation and prototyping platform for SEGGER software User Guide & Reference
      Manual
*/

/*****
*
*      #include section
*
*****/
#include "FS.h"

/*****
*
*      Defines, configurable
*
*****/
#ifndef FS_NOR_HW_SPI_BUS_CLK_HZ
#define FS_NOR_HW_SPI_BUS_CLK_HZ      (16800000uL / 3) // SPI module clock
#endif

#ifndef FS_NOR_HW_SPI_NOR_CLK_HZ
#define FS_NOR_HW_SPI_NOR_CLK_HZ      2800000uL      // Clock of NOR flash device
#endif

#ifndef FS_NOR_HW_SPI_INIT_WAIT_LOOPS
#define FS_NOR_HW_SPI_INIT_WAIT_LOOPS  2000          // Waits about
// lms for the SPI module to start/stop
#endif

#ifndef FS_NOR_HW_SPI_UNIT_NO
#define FS_NOR_HW_SPI_UNIT_NO          0
// Selects the number of SPI unit to be used for data transfer (Permitted values: 0 and 2)
#endif

#ifndef FS_NOR_HW_SPI_USE_OS
#define FS_NOR_HW_SPI_USE_OS           0
// Enables / disables the event-driven operation.
// 0
- OS support disabled.
// 1
- OS support enabled using OS event of emFile.
// 2
- OS support enabled using OS events of this HW layer.
#endif

/*****
*
*      #include section, conditional
*
*****/
#if FS_NOR_HW_SPI_USE_OS
#include "FS_OS.h"
#include "RTOS.h"
#include "MK66F18.h"

```

```

#endif // FS_NOR_HW_SPI_USE_OS

/*****
 *
 *     Defines, fixed
 *
 *****/

/*****
 *
 *     SPI module
 */
#if (FS_NOR_HW_SPI_UNIT_NO == 2)
    #define SPI_BASE_ADDR    0x400AC000uL
#else
    #define SPI_BASE_ADDR    0x4002C000uL
#endif
#define SPI_MCR              (*(volatile U32 *) (SPI_BASE_ADDR + 0x00))
    // Module Configuration Register
#define SPI_TCR              (*(volatile U32 *) (SPI_BASE_ADDR + 0x08))
    // Transfer Count Register
#define SPI_CTAR0           (*(volatile U32 *) (SPI_BASE_ADDR + 0x0C))
    // Clock and Transfer Attributes Register (In Master Mode)
#define SPI_CTAR1           (*(volatile U32 *) (SPI_BASE_ADDR + 0x10))
    // Clock and Transfer Attributes Register (In Master Mode)
#define SPI_SR              (*(volatile U32 *) (SPI_BASE_ADDR + 0x2C))    // Status Register
#define SPI_RSER            (*(volatile U32 *) (SPI_BASE_ADDR + 0x30))
    // DMA/Interrupt Request Select and Enable Register
#define SPI_PUSHR           (*(volatile U32 *) (SPI_BASE_ADDR + 0x34))
    // PUSH TX FIFO Register In Master Mode
#define SPI_POPR            (*(volatile U32 *) (SPI_BASE_ADDR + 0x38))
    // POP RX FIFO Register
#define SPI_TXFR0           (*(volatile U32 *) (SPI_BASE_ADDR + 0x3C))
    // Transmit FIFO Registers
#define SPI_TXFR1           (*(volatile U32 *) (SPI_BASE_ADDR + 0x40))
    // Transmit FIFO Registers
#define SPI_TXFR2           (*(volatile U32 *) (SPI_BASE_ADDR + 0x44))
    // Transmit FIFO Registers
#define SPI_TXFR3           (*(volatile U32 *) (SPI_BASE_ADDR + 0x48))
    // Transmit FIFO Registers
#define SPI_RXFR0           (*(volatile U32 *) (SPI_BASE_ADDR + 0x7C))
    // Receive FIFO Registers
#define SPI_RXFR1           (*(volatile U32 *) (SPI_BASE_ADDR + 0x80))
    // Receive FIFO Registers
#define SPI_RXFR2           (*(volatile U32 *) (SPI_BASE_ADDR + 0x84))
    // Receive FIFO Registers
#define SPI_RXFR3           (*(volatile U32 *) (SPI_BASE_ADDR + 0x88))
    // Receive FIFO Registers

#if (FS_NOR_HW_SPI_USE_OS == 0)

/*****
 *
 *     System integration module
 */
#define SIM_BASE_ADDR       0x40047000uL
#define SIM_SCGC3           (*(volatile U32 *) (SIM_BASE_ADDR + 0x1030))
    // System Clock Gating Control Register 3
#define SIM_SCGC5           (*(volatile U32 *) (SIM_BASE_ADDR + 0x1038))
    // System Clock Gating Control Register 5
#define SIM_SCGC6           (*(volatile U32 *) (SIM_BASE_ADDR + 0x103C))
    // System Clock Gating Control Register 6

/*****
 *
 *     Port B
 */
#define PORTB_BASE_ADDR     0x4004A000uL
#define PORTB_PCR20         (*(volatile U32 *) (PORTB_BASE_ADDR + 0x50))
    // Port Control Register
#define PORTB_PCR21         (*(volatile U32 *) (PORTB_BASE_ADDR + 0x54))
    // Port Control Register
#define PORTB_PCR22         (*(volatile U32 *) (PORTB_BASE_ADDR + 0x58))
    // Port Control Register

```

```

#define PORTB_PCR23      (*(volatile U32 *) (PORTB_BASE_ADDR + 0x5C))
// Port Control Register
#define PORTB_DFER      (*(volatile U32 *) (PORTB_BASE_ADDR + 0xC0))
// Digital filter enable register

/*****
*
*       Port C
*/
#define PORTC_BASE_ADDR      0x4004B000uL
#define PORTC_PCR4          (*(volatile U32 *) (PORTC_BASE_ADDR + 0x10))
// Port Control Register
#define PORTC_PCR5          (*(volatile U32 *) (PORTC_BASE_ADDR + 0x14))
// Port Control Register
#define PORTC_PCR6          (*(volatile U32 *) (PORTC_BASE_ADDR + 0x18))
// Port Control Register
#define PORTC_PCR7          (*(volatile U32 *) (PORTC_BASE_ADDR + 0x1C))
// Port Control Register
#define PORTC_DFER          (*(volatile U32 *) (PORTC_BASE_ADDR + 0xC0))
// Digital filter enable register

/*****
*
*       GPIO B
*/
#define GPIOB_BASE_ADDR      0x400FF040uL
#define GPIOB_PDOR          (*(volatile U32 *) (GPIOB_BASE_ADDR + 0x00))
// Port Data Output Register
#define GPIOB_PSOR          (*(volatile U32 *) (GPIOB_BASE_ADDR + 0x04))
// Port Set Output Register
#define GPIOB_PCOR          (*(volatile U32 *) (GPIOB_BASE_ADDR + 0x08))
// Port Clear Output Register
#define GPIOB_PTOR          (*(volatile U32 *) (GPIOB_BASE_ADDR + 0x0C))
// Port Toggle Output Register
#define GPIOB_PDIR          (*(volatile U32 *) (GPIOB_BASE_ADDR + 0x10))
// Port Data Input Register
#define GPIOB_PDDR          (*(volatile U32 *) (GPIOB_BASE_ADDR + 0x14))
// Port Data Direction Register

/*****
*
*       GPIO C
*/
#define GPIOC_BASE_ADDR      0x400FF080uL
#define GPIOC_PDOR          (*(volatile U32 *) (GPIOC_BASE_ADDR + 0x00))
// Port Data Output Register
#define GPIOC_PSOR          (*(volatile U32 *) (GPIOC_BASE_ADDR + 0x04))
// Port Set Output Register
#define GPIOC_PCOR          (*(volatile U32 *) (GPIOC_BASE_ADDR + 0x08))
// Port Clear Output Register
#define GPIOC_PTOR          (*(volatile U32 *) (GPIOC_BASE_ADDR + 0x0C))
// Port Toggle Output Register
#define GPIOC_PDIR          (*(volatile U32 *) (GPIOC_BASE_ADDR + 0x10))
// Port Data Input Register
#define GPIOC_PDDR          (*(volatile U32 *) (GPIOC_BASE_ADDR + 0x14))
// Port Data Direction Register

#else

/*****
*
*       Port C
*/
#define PORTC_BASE_ADDR      0x4004B000uL
#define PORTC_DFER          (*(volatile U32 *) (PORTC_BASE_ADDR + 0xC0))
// Digital filter enable register

#endif // FS_NOR_HW_SPI_USE_OS

/*****
*
*       Port Control Register
*/
#define PCR_MUX_BIT          8 // Alternate port setting
#define PCR_MUX_GPIO        1uL // Controlled directly by the HW layer
#define PCR_MUX_SPI         2uL // Controlled by SPI module

```

```

#define PCR_MUX_SPI2      2uL // Controlled by SPI module
#define PCR_MUX_MASK      0x7uL
#define PCR_DSE_BIT       6 // Driver strength enable
#define PCR_PE_BIT        1 // Pull enable
#define PCR_PS_BIT        0 // Pull-up enable

/*****
 *
 *      Clock enable bits
 */
#define SCGC3_SPI2_BIT    12 // SPI2
#define SCGC5_PORTB_BIT  10 // GPIO B
#define SCGC5_PORTC_BIT  11 // GPIO C
#define SCGC6_SPI0_BIT    12 // SPI0

/*****
 *
 *      SPI Module Configuration Register
 */
#define MCR_MSTR_BIT      31
#define MCR_FRZ_BIT      27
#define MCR_CLR_TXF_BIT  11
#define MCR_CLR_RXF_BIT  10
#define MCR_HALT_BIT     0

/*****
 *
 *      SPI Status Register
 */
#define SR_TCF_BIT        31
#define SR_TXRXS_BIT     30
#define SR_EOQF_BIT      28
#define SR_TFUF_BIT      27
#define SR_TFFF_BIT      25
#define SR_RFOF_BIT      19
#define SR_RFDF_BIT      17
#define SR_RXCTR_BIT     4
#define SR_RXCTR_MASK    0xFuL

/*****
 *
 *      SPI Clock and Transfer Attributes Register
 */
#define CTAR_DBR_BIT      31
#define CTAR_FMSZ_BIT     27
#define CTAR_CPOL_BIT     26
#define CTAR_CPHA_BIT     25
#define CTAR_BR_BIT       0
#define CTAR_BR_MAX      0xFuL

/*****
 *
 *      SPI misc. defines
 */
#define PUSHR_CTAS_BIT    28
#define RSER_RFDF_RE_BIT  17
#define SPI_IRQ_PRIO     15
#define WAIT_TIMEOUT_MS  1000

/*****
 *
 *      NOR flash pin assignments
 */
#if (FS_NOR_HW_SPI_UNIT_NO == 2)
#define NOR_CS_PIN        20 // Port B
#define NOR_CLK_PIN       21 // Port B
#define NOR_MOSI_PIN      22 // Port B
#define NOR_MISO_PIN      23 // Port B
#else
#define NOR_CS_PIN        4 // Port C
#define NOR_CLK_PIN       5 // Port C
#define NOR_MOSI_PIN      6 // Port C
#define NOR_MISO_PIN      7 // Port C
#endif

/*****

```

```

*
*   Static data
*
*****
*/
#if (FS_NOR_HW_SPI_USE_OS == 2)
    static U8      _IsEventInitd = 0;
    static OS_EVENT _Event;
#endif // FS_NOR_HW_SPI_USE_OS == 2

/*****
*
*   Static code
*
*****
*/

#if FS_NOR_HW_SPI_USE_OS

/*****
*
*   _WaitForEvent
*
*   Function description
*   Waits for the interrupt to wake up the task.
*
*   Parameters
*   Timeout      Maximum time to wait for the event in milliseconds.
*
*   Return values
*   ==0          OK, event signaled.
*   !=0         An error occurred.
*/
static int _WaitForEvent(U32 Timeout) {
    int r;

    SPI_RSER |= 1uL << RSER_RFDF_RE_BIT; // Enable the interrupt.
#if (FS_NOR_HW_SPI_USE_OS == 2)
    r = OS_EVENT_WaitTimed(&_Event, Timeout);
#else
    r = FS_OS_Wait(Timeout);
#endif
    if (r != 0) {
        SPI_RSER &= ~(1uL << RSER_RFDF_RE_BIT); // Disable the interrupt.
    }
    return r;
}

#endif // FS_NOR_HW_SPI_USE_OS

/*****
*
*   _StoreU16BE
*
*   Function description
*   Stores a 16 bit value in big endian format into a byte array.
*/
static void _StoreU16BE(U8 *pBuffer, unsigned Data) {
    *pBuffer++ = (U8)(Data >> 8);
    *pBuffer   = (U8) Data;
}

/*****
*
*   _LoadU16BE
*
*   Function description
*   Reads a 16 bit value stored in big endian format from a byte array.
*/
static U16 _LoadU16BE(const U8 * pBuffer) {
    U16 r;

    r = *pBuffer++;
    r = (U16)((r << 8) | *pBuffer);
    return r;
}

```

```

/*****
*
*     _Transfer8Bit
*/
static U8 _Transfer8Bit(U8 Data) {
    U32 NumBytes;

    SPI_PUSHR = Data;
    //
    // Wait to receive 1 byte.
    //
    while (1) {
        NumBytes = (SPI_SR >> SR_RXCTR_BIT) & SR_RXCTR_MASK;
        if (NumBytes == 1) {
            break;
        }
    }
#if FS_NOR_HW_SPI_USE_OS
    {
        int r;

        r = _WaitForEvent(WAIT_TIMEOUT_MS);
        if (r != 0) {
            break;
        }
    }
#endif // FS_NOR_HW_SPI_USE_OS
    Data = (U8)SPI_POPR;
    return Data;
}

#if (FS_NOR_HW_SPI_UNIT_NO == 0)

/*****
*
*     _Read64Bits
*
* Function description
* Transfers 64 bits of data from NOR device to MCU.
*/
static void _Read64Bits(U8 * pData) {
    U16 Data16;
    U32 NumItems;
    U32 Dummy;

    //
    // Send dummy data.
    //
    Dummy = 0
           | 0xFFFFuL
           | (1uL << PUSHR_CTAS_BIT)
    // Use the second set of parameters which is configured for 16-bit transfers.
    ;
    SPI_PUSHR = Dummy;
    SPI_PUSHR = Dummy;
    SPI_PUSHR = Dummy;
    SPI_PUSHR = Dummy;
    //
    // Wait to receive 4 half-words (4 is the FIFO size)
    //
    while (1) {
        NumItems = (SPI_SR >> SR_RXCTR_BIT) & SR_RXCTR_MASK;
        if (NumItems == 4) {
            break;
        }
    }
#if FS_NOR_HW_SPI_USE_OS
    {
        int r;

        r = _WaitForEvent(WAIT_TIMEOUT_MS);
        if (r != 0) {
            break;
        }
    }
#endif // FS_NOR_HW_SPI_USE_OS
}

```



```

}
//
// Read data from FIFO.
//
Data16 = (U16)SPI_POPR;
_StoreU16BE(pData, Data16);
Data16 = (U16)SPI_POPR;
_StoreU16BE(pData + 2, Data16);
Data16 = (U16)SPI_POPR;
_StoreU16BE(pData + 4, Data16);
Data16 = (U16)SPI_POPR;
_StoreU16BE(pData + 6, Data16);
}

/*****
*
*      _Write64Bits
*
* Function description
* Transfers 64 bits of data from MCU to NOR device.
*/
static void _Write64Bits(const U8 * pData) {
    U16 Data16;
    U32 NumItems;

    //
    // Write data to NOR device. Use the second set of parameters which is configured for
    // 16-bit transfers.
    //
    Data16 = _LoadU16BE(pData);
    SPI_PUSHR = (U32)Data16 | (1uL << PUSHR_CTAS_BIT);
    Data16 = _LoadU16BE(pData + 2);
    SPI_PUSHR = (U32)Data16 | (1uL << PUSHR_CTAS_BIT);
    Data16 = _LoadU16BE(pData + 4);
    SPI_PUSHR = (U32)Data16 | (1uL << PUSHR_CTAS_BIT);
    Data16 = _LoadU16BE(pData + 6);
    SPI_PUSHR = (U32)Data16 | (1uL << PUSHR_CTAS_BIT);
    //
    // Wait to receive 4 half-words (4 is the FIFO size)
    //
    while (1) {
        NumItems = (SPI_SR >> SR_RXCTR_BIT) & SR_RXCTR_MASK;
        if (NumItems == 4) {
            break;
        }
#ifdef FS_NOR_HW_SPI_USE_OS
    {
        int r;

        r = _WaitForEvent(WAIT_TIMEOUT_MS);
        if (r != 0) {
            break;
        }
    }
#endif // FS_NOR_HW_SPI_USE_OS
    }
    //
    // Discard the received data.
    //
    SPI_MCR |= 1uL << MCR_CLR_RXF_BIT;
}

#endif // FS_NOR_HW_SPI_UNIT_NO == 0

/*****
*
*      Static code (public via callback)
*
*****/

/*****
*
*      _HW_Init
*
* Function description

```

```

*   Initialize the SPI for use with the NOR flash.
*
*   Parameters
*   Unit   Device index
*
*   Return value
*   SPI frequency that is set - given in kHz, 0 in case of an error.
*/
static int _HW_Init(U8 Unit) {
    int     Freq_Hz;
    unsigned NumLoops;
    unsigned Scaler;
    unsigned Div;

    FS_USE_PARA(Unit);
#if (FS_NOR_HW_SPI_UNIT_NO == 2)
    //
    // Enable the clock of GPIOs and SPI0.
    //
    SIM_SCGC3 |= 1uL << SCGC3_SPI2_BIT;
    SIM_SCGC5 |= 1uL << SCGC5_PORTB_BIT;
    //
    // Clock line (controlled by the SPI module)
    //
    PORTB_PCR21 = 0
                | (PCR_MUX_SPI2 << PCR_MUX_BIT)
                | (1uL << PCR_PE_BIT)
                | (1uL << PCR_PS_BIT)
                | (1uL << PCR_DSE_BIT)
                ;

    //
    // MOSI line (controlled by the SPI module)
    //
    PORTB_PCR22 = 0
                | (PCR_MUX_SPI2 << PCR_MUX_BIT)
                | (1uL << PCR_PE_BIT)
                | (1uL << PCR_PS_BIT)
                | (1uL << PCR_DSE_BIT)
                ;

    //
    // MISO line (controlled by the SPI module)
    //
    PORTB_PCR23 = 0
                | (PCR_MUX_SPI2 << PCR_MUX_BIT)
                | (1uL << PCR_PE_BIT)
                | (1uL << PCR_PS_BIT)
                | (1uL << PCR_DSE_BIT)
                ;

    //
    // Chip select (controlled by the HW layer)
    //
    PORTB_PCR20 = 0
                | (PCR_MUX_GPIO << PCR_MUX_BIT)
                | (1uL << PCR_PE_BIT)
                | (1uL << PCR_PS_BIT)
                ;

    GPIOB_PSOR = 1uL << NOR_CS_PIN;           // Active low
    GPIOB_PDDR |= 1uL << NOR_CS_PIN;
    //
    // Disable the digital filtering on all port pins controlled by the SPI module.
    //
    PORTB_DFER &= ~((1uL << NOR_CLK_PIN) |
                   (1uL << NOR_MISO_PIN) |
                   (1uL << NOR_MOSI_PIN));
#else
    //
    // Enable the clock of GPIOs and SPI0.
    //
    SIM_SCGC5 |= 1uL << SCGC5_PORTC_BIT;
    SIM_SCGC6 |= 1uL << SCGC6_SPI0_BIT;
    //
    // Clock line (controlled by the SPI module)
    //
    PORTC_PCR5 = 0
                | (PCR_MUX_SPI0 << PCR_MUX_BIT)
                | (1uL << PCR_PE_BIT)

```

```

        | (1uL          << PCR_PS_BIT)
        | (1uL          << PCR_DSE_BIT)
        ;

//
// MOSI line (controlled by the SPI module)
//
PORTC_PCR6 = 0
        | (PCR_MUX_SPI0 << PCR_MUX_BIT)
        | (1uL          << PCR_PE_BIT)
        | (1uL          << PCR_PS_BIT)
        | (1uL          << PCR_DSE_BIT)
        ;

//
// MISO line (controlled by the SPI module)
//
PORTC_PCR7 = 0
        | (PCR_MUX_SPI0 << PCR_MUX_BIT)
        | (1uL          << PCR_PE_BIT)
        | (1uL          << PCR_PS_BIT)
        | (1uL          << PCR_DSE_BIT)
        ;

//
// Chip select (controlled by the HW layer)
//
PORTC_PCR4 = 0
        | (PCR_MUX_GPIO << PCR_MUX_BIT)
        | (1uL          << PCR_PE_BIT)
        | (1uL          << PCR_PS_BIT)
        ;

GPIOC_PSOR = 1uL << NOR_CS_PIN;          // Active low
GPIOC_PDDR |= 1uL << NOR_CS_PIN;
//
// Disable the digital filtering on all port pins controlled by the SPI module.
//
PORTC_DFER &= ~((1uL << NOR_CLK_PIN) |
                (1uL << NOR_MISO_PIN) |
                (1uL << NOR_MOSI_PIN));
#endif // FS_NOR_HW_SPI_UNIT_NO == 2
#if FS_NOR_HW_SPI_USE_OS
//
// Disable the interrupt and configure the priority.
//
NVIC_DisableIRQ(SPI0_IRQn);
NVIC_SetPriority(SPI0_IRQn, SPI_IRQ_PRIO);
#endif // FS_NOR_HW_SPI_USE_OS
//
// Calculate the clock scaler based on the configured clock frequency.
//
Scaler = 0;
Div = 2;
Freq_Hz = FS_NOR_HW_SPI_BUS_CLK_HZ;
for (;;) {
    if (((unsigned)Freq_Hz / Div) <= FS_NOR_HW_SPI_NOR_CLK_HZ) {
        break;
    }
    //
    // We do this here since the 3rd divisor is not power of 2.
    //
    if (Div == 2) {
        Div = 4;
    } else if (Div == 4) {
        Div = 6;
    } else if (Div == 6) {
        Div = 8;
    } else {
        Div <<= 1;
    }
    ++Scaler;
    if (Scaler == CTAR_BR_MAX) {
        break;
    }
}
//
// Stop the SPI module.
//
SPI_MCR |= 1uL << MCR_HALT_BIT;

```

```

NumLoops = FS_NOR_HW_SPI_INIT_WAIT_LOOPS;
do {
    if ((SPI_SR & (1uL << SR_TXRXS_BIT)) == 0) {
        break;
    }
} while (--NumLoops);
//
// Configure the SPI module.
//
SPI_MCR = 0
        | (1uL << MCR_MSTR_BIT)
        | (1uL << MCR_CLR_TXF_BIT)
        | (1uL << MCR_CLR_RXF_BIT)
        | (1uL << MCR_HALT_BIT)
        ;

SPI_TCR = 0;
SPI_CTAR0 = 0
           | (1uL << CTAR_DBR_BIT)
           | (7uL << CTAR_FMSZ_BIT) // 8 bits
           | (1uL << CTAR_CPOL_BIT)
           | (1uL << CTAR_CPHA_BIT)
           | (Scaler << CTAR_BR_BIT)
           ;

SPI_CTAR1 = 0
           | (1uL << CTAR_DBR_BIT)
           | (15uL << CTAR_FMSZ_BIT) // 16 bits
           | (1uL << CTAR_CPOL_BIT)
           | (1uL << CTAR_CPHA_BIT)
           | (Scaler << CTAR_BR_BIT)
           ;

SPI_SR = 0
        | (1uL << SR_TCF_BIT)
        | (1uL << SR_EOQF_BIT)
        | (1uL << SR_TFUF_BIT)
        | (1uL << SR_TFFF_BIT)
        | (1uL << SR_RFOF_BIT)
        | (1uL << SR_RFDF_BIT)
        ;

//
// Start the SPI module.
//
SPI_MCR &= ~(1uL << MCR_HALT_BIT);
NumLoops = FS_NOR_HW_SPI_INIT_WAIT_LOOPS;
do {
    if (SPI_SR & (1uL << SR_TXRXS_BIT)) {
        break;
    }
} while (--NumLoops);
#if FS_NOR_HW_SPI_USE_OS
//
// Create the OS event and enable the interrupt.
//
#if (FS_NOR_HW_SPI_USE_OS == 2)
if (_IsEventInitiated == 0) {
    OS_EVENT_Create(&_Event);
    _IsEventInitiated = 1;
}
#endif // FS_NOR_HW_SPI_USE_OS == 2
NVIC_EnableIRQ(SPI0_IRQn);
#endif // FS_NOR_HW_SPI_USE_OS
//
// Make a dummy transfer so that the polarity of the clock signal is set correctly.
// Without this, the first byte transfer will send/receive the wrong value.
//
_Transfer8Bit(0xFF);
#if (FS_NOR_HW_SPI_USE_OS == 0)
SPI_RSER = 0;
#endif
return Freq_Hz;
}

/*****
*
*     _HW_EnableCS
*
* Function description
*****/

```

```

*   Activates chip select signal (CS) of the NOR flash chip.
*
*   Parameters
*   Unit      Device index
*/
static void _HW_EnableCS(U8 Unit) {
    FS_USE_PARA(Unit);
#if (FS_NOR_HW_SPI_UNIT_NO == 2)
    GPIOB_PCOR = 1uL << NOR_CS_PIN;           // Active low
#else
    GPIOC_PCOR = 1uL << NOR_CS_PIN;           // Active low
#endif
}

/*****
*
*   _HW_DisableCS
*
*   Function description
*   Deactivates chip select signal (CS) of the NOR flash chip.
*
*   Parameters
*   Unit      Device index
*/
static void _HW_DisableCS(U8 Unit) {
    FS_USE_PARA(Unit);
#if (FS_NOR_HW_SPI_UNIT_NO == 2)
    GPIOB_PSOR = 1uL << NOR_CS_PIN;           // Active low
#else
    GPIOC_PSOR = 1uL << NOR_CS_PIN;           // Active low
#endif
}

/*****
*
*   _HW_Read
*
*   Function description
*   Reads a specified number of bytes from NOR flash to buffer.
*
*   Parameters
*   Unit      Device index
*   pData     Pointer to a data buffer
*   NumBytes  Number of bytes to be read
*/
static void _HW_Read(U8 Unit, U8 * pData, int NumBytes) {
    FS_USE_PARA(Unit);
    if (NumBytes) {
#if (FS_NOR_HW_SPI_UNIT_NO == 2)
        do {
            *pData++ = _Transfer8Bit(0xFF);
        } while (--NumBytes);
#else
        //
        // Read 64 bits at a time if possible.
        //
        if (((unsigned)NumBytes & 7) == 0) { // Multiple of 8 bytes?
            unsigned NumLoops;

            NumLoops = (unsigned)NumBytes >> 3;
            do {
                _Read64Bits(pData);
                pData += 8;
            } while (--NumLoops);
        } else {
            do {
                *pData++ = _Transfer8Bit(0xFF);
            } while (--NumBytes);
        }
#endif
    }
}

/*****
*
*   _HW_Write

```

```

*
* Function description
*   Writes a specified number of bytes from data buffer to NOR flash.
*
* Parameters
*   Unit       Device index
*   pData      Pointer to a data buffer
*   NumBytes   Number of bytes to be written
*/
static void _HW_Write(U8 Unit, const U8 * pData, int NumBytes) {
    FS_USE_PARA(Unit);
    if (NumBytes) {
#if (FS_NOR_HW_SPI_UNIT_NO == 2)
        do {
            (void)_Transfer8Bit(*pData++);
        } while (--NumBytes);
#else
        //
        // Write 64 bits at a time if possible.
        //
        if (((unsigned)NumBytes & 7) == 0) { // Multiple of 8 bytes?
            unsigned NumLoops;

            NumLoops = (unsigned)NumBytes >> 3;
            do {
                _Write64Bits(pData);
                pData += 8;
            } while (--NumLoops);
        } else {
            do {
                (void)_Transfer8Bit(*pData++);
            } while (--NumBytes);
        }
#endif
    }
}

/*****
*
*   Public code
*
*****/

#if FS_NOR_HW_SPI_USE_OS

/*****
*
*   SPI0_IRQHandler
*/
void SPI0_IRQHandler(void);
void SPI0_IRQHandler(void) {
    OS_EnterInterrupt();
    SPI_RSER &= ~(1uL << RSER_RFDF_RE_BIT); // Disable the interrupt.
#if (FS_NOR_HW_SPI_USE_OS == 2)
    OS_EVENT_Set(&_Event);
#else
    FS_OS_Signal();
#endif // FS_NOR_HW_SPI_USE_OS == 2
    OS_LeaveInterrupt();
}

#endif // FS_NOR_HW_SPI_USE_OS

/*****
*
*   Public data
*
*****/
const FS_NOR_HW_TYPE_SPI FS_NOR_HW_SPI_K66_SEGGER_emPower = {
    _HW_Init,
    _HW_EnableCS,
    _HW_DisableCS,
    _HW_Read,
    _HW_Write,

```

```
NULL,  
NULL,  
NULL,  
NULL,  
NULL,  
NULL,  
NULL,  
NULL,  
NULL,  
NULL,  
NULL  
};  
  
/***** End of file *****/
```

6.4.5.3 Hardware layer API - FS_NOR_HW_TYPE_SPIFI

This hardware layer supports serial NOR flash devices that are interfaced via SPI with their data content being mapped to the system memory of the MCU. This type of interface translates read accesses to the system memory region where the serial NOR flash device is mapped to read operations via SPI bus. Therefore, the hardware layer can read the data from the serial NOR flash device by simply reading data from the system memory. Any other operations with the serial NOR flash device are performed by sending the commands directly via the SPI bus.

That is this hardware layer is able to transfer the data via one, two or four data lines. The functions of this hardware layer are grouped in a structure of type `FS_NOR_HW_TYPE_SPIFI`. The following sections describe these functions in detail.

6.4.5.3.1 FS_NOR_HW_TYPE_SPIFI

Description

Hardware layer for serial NOR flash devices that are memory-mapped.

Type definition

```
typedef struct {
    FS_NOR_HW_TYPE_SPIFI_INIT      * pfInit;
    FS_NOR_HW_TYPE_SPIFI_UNMAP     * pfSetCmdMode;
    FS_NOR_HW_TYPE_SPIFI_MAP       * pfSetMemMode;
    FS_NOR_HW_TYPE_SPIFI_CONTROL   * pfExecCmd;
    FS_NOR_HW_TYPE_SPIFI_READ      * pfReadData;
    FS_NOR_HW_TYPE_SPIFI_WRITE     * pfWriteData;
    FS_NOR_HW_TYPE_SPIFI_POLL      * pfPoll;
    FS_NOR_HW_TYPE_SPIFI_DELAY     * pfDelay;
    FS_NOR_HW_TYPE_SPIFI_LOCK      * pfLock;
    FS_NOR_HW_TYPE_SPIFI_UNLOCK    * pfUnlock;
    FS_NOR_HW_TYPE_SPIFI_MAP_EX    * pfMapEx;
    FS_NOR_HW_TYPE_SPIFI_CONTROL_EX * pfControlEx;
    FS_NOR_HW_TYPE_SPIFI_READ_EX   * pfReadEx;
    FS_NOR_HW_TYPE_SPIFI_WRITE_EX  * pfWriteEx;
    FS_NOR_HW_TYPE_SPIFI_POLL_EX   * pfPollEx;
} FS_NOR_HW_TYPE_SPIFI;
```

Structure members

Member	Description
pfInit	Initializes the hardware.
pfSetCmdMode	Configures the hardware for direct access to serial NOR flash.
pfSetMemMode	Configures the hardware for access to serial NOR flash via system memory.
pfExecCmd	Sends a command to serial NOR flash that does not transfer any data.
pfReadData	Transfers data from serial NOR flash to MCU.
pfWriteData	Transfers data from MCU to serial NOR flash.
pfPoll	Checks periodically the value of a status flag.
pfDelay	Blocks the execution for the specified time.
pfLock	Requests exclusive access to SPI bus.
pfUnlock	Releases the exclusive access to SPI bus.
pfMapEx	Configures the hardware for access to serial NOR flash via system memory.
pfControlEx	Sends a command to serial NOR flash that does not transfer any data.
pfReadEx	Transfers data from serial NOR flash to MCU.
pfWriteEx	Transfers data from MCU to serial NOR flash.
pfPollEx	Checks periodically the value of a status flag.

6.4.5.3.2 FS_NOR_HW_TYPE_SPIFI_INIT

Description

Initializes the SPI hardware.

Type definition

```
typedef int FS_NOR_HW_TYPE_SPIFI_INIT(U8 Unit);
```

Parameters

Parameter	Description
<code>Unit</code>	Index of the hardware layer (0-based).

Return value

> 0 OK, frequency of the SPI clock in Hz.
= 0 An error occurred.

Additional information

This function is a member of the SPIFI NOR hardware layer API. It has to be implemented by all the hardware layers.

This function is called by the NOR physical layer before any other function of the hardware layer each time the file system mounts the serial NOR flash. `FS_NOR_HW_TYPE_SPIFI_INIT` has to perform the initialization of clock signals, GPIO ports, SPI controller, etc.

6.4.5.3.3 FS_NOR_HW_TYPE_SPIFI_UNMAP

Description

Configures the hardware for direct access to serial NOR flash.

Type definition

```
typedef void FS_NOR_HW_TYPE_SPIFI_UNMAP(U8 Unit);
```

Parameters

Parameter	Description
<code>Unit</code>	Index of the hardware layer (0-based).

Additional information

This function is a member of the SPIFI NOR hardware layer API. It has to be implemented by all the hardware layers.

The physical layer calls this function before it starts sending commands directly to the serial NOR flash. Typically, the SPI hardware can operate in two modes: command and memory. In command mode the physical layer can access the serial NOR flash directly by sending commands to it. In the memory mode the SPI hardware translates read accesses to an assigned memory region to serial NOR flash read commands. In this way, the contents of the contents of the serial NOR flash is mapped into this memory region.

If the command and memory mode are mutually exclusive, `FS_NOR_HW_TYPE_SPIFI_UNMAP` has to disable the memory mode.

6.4.5.3.4 FS_NOR_HW_TYPE_SPIFI_MAP

Description

Configures the hardware for access to serial NOR flash via system memory.

Type definition

```
typedef void FS_NOR_HW_TYPE_SPIFI_MAP(U8      Unit,
                                       U8      ReadCmd,
                                       unsigned NumBytesAddr,
                                       unsigned NumBytesDummy,
                                       U16     BusWidth);
```

Parameters

Parameter	Description
Unit	Index of the hardware layer (0-based).
ReadCmd	Code of the command to be used for reading the data.
NumBytesAddr	Number of address bytes to be used for the read command.
NumBytesDummy	Number of dummy bytes to be sent after the read command.
BusWidth	Number of data lines to be used for the data transfer.

Additional information

This function is a member of the SPIFI NOR hardware layer API. The implementation of this function is not required if the hardware layer implements `FS_NOR_HW_TYPE_SPIFI_MAP_EX`.

This function is called by the physical layer when it no longer wants to send commands directly to the serial NOR flash device. After the call to this function the physical layer expects that the contents of the serial NOR flash device is available in the system memory region assigned to SPI hardware and that the data can be accessed by simple memory read operations.

If the command and memory mode are mutually exclusive, then `FS_NOR_HW_TYPE_SPIFI_MAP` has to disable the command mode.

If the specified read command requires the generation of a number of dummy cycles that is not a multiple of eight then the hardware layer will have to implement the `FS_NOR_HW_TYPE_SPIFI_MAP_EX` function.

[BusWidth](#) encodes the number of data lines to be used when transferring the command, address and data. The value can be decoded using `FS_BUSWIDTH_GET_CMD()`, `FS_BUSWIDTH_GET_ADDR()` and `FS_BUSWIDTH_GET_DATA()`. The dummy bytes are sent using the same number of data lines as the address. For additional information refer to *SPI bus width decoding* on page 704

6.4.5.3.5 FS_NOR_HW_TYPE_SPIFI_CONTROL

Description

Sends a command to serial NOR flash that does not transfer any data.

Type definition

```
typedef void FS_NOR_HW_TYPE_SPIFI_CONTROL(U8 Unit,
                                           U8 Cmd,
                                           U8 BusWidth);
```

Parameters

Parameter	Description
<code>Unit</code>	Index of the hardware layer (0-based).
<code>Cmd</code>	Code of the command to be sent.
<code>BusWidth</code>	Number of data lines to be used for sending the command.

Additional information

This function is a member of the SPIFI NOR hardware layer API. The implementation of this function is not required if the hardware layer implements `FS_NOR_HW_TYPE_SPIFI_CONTROL_EX`.

Typically, the physical layer calls `FS_NOR_HW_TYPE_SPIFI_CONTROL` to enable or disable the write mode in the serial NOR flash, to set the number of address bytes, etc. `FS_NOR_HW_TYPE_SPIFI_CONTROL` is called by the physical layer only with the SPI hardware configured in command mode. `FS_NOR_HW_TYPE_SPIFI_CONTROL` has to wait for the command to complete before it returns.

The value of `BusWidth` is not encoded as is the case with the other functions of this physical layer. The value specified via `BusWidth` is the actual number of data lines that have to be used for the data transfer of the command code. Permitted values are 1, 2, and 4.

6.4.5.3.6 FS_NOR_HW_TYPE_SPIFI_READ

Description

Transfers data from serial NOR flash to MCU.

Type definition

```
typedef void FS_NOR_HW_TYPE_SPIFI_READ(
    U8      Unit,
    U8      Cmd,
    const U8 * pPara,
    unsigned NumBytesPara,
    unsigned NumBytesAddr,
    U8      * pData,
    unsigned NumBytesData,
    U16     BusWidth);
```

Parameters

Parameter	Description
Unit	Index of the hardware layer (0-based).
Cmd	Code of the command to be sent.
pPara	in Command parameters (address and dummy bytes). Can be NULL.
NumBytesPara	Total number of address and dummy bytes to be sent. Can be 0.
NumBytesAddr	Number of address bytes to be send. Can be 0.
pData	out Data read from the serial NOR flash device. Can be NULL.
NumBytesData	Number of bytes to read from the serial NOR flash device. Can be 0.
BusWidth	Number of data lines to be used for the data transfer.

Additional information

This function is a member of the SPIFI NOR hardware layer API. The implementation of this function is not required if the hardware layer implements `FS_NOR_HW_TYPE_SPIFI_READ_EX`.

This function is called with the SPI hardware in command mode. Typically, the physical layer calls this function when it wants to read parameters or status information from the serial NOR flash device. `FS_NOR_HW_TYPE_SPIFI_READ` has to wait for the data transfer to complete before it returns.

If `FS_NOR_HW_TYPE_SPIFI_MAP` is provided then the physical layer reads the contents of the serial NOR flash device via reads accesses to the system memory. `FS_NOR_HW_TYPE_SPIFI_READ` is used by the physical layer to read the contents of the serial NOR flash device if `FS_NOR_HW_TYPE_SPIFI_MAP` is not provided.

The first address byte is stored at `*pPara`. `NumBytesAddr` is always smaller than or equal to `NumBytesPara`. If `NumBytesAddr` is equal to `NumBytesPara` then no dummy bytes have to be generated. The number of dummy bytes to be generated can be calculated as `NumBytesPara - NumBytesAddr`. If the hardware is generating dummy cycles instead of bytes then the number of dummy bytes have to converted to clock cycles by taking into account the number of data lines used for the data transfer of the address. If the specified read command requires the generation of a number of dummy cycles that is not a multiple of eight then the hardware layer will have to implement the `FS_NOR_HW_TYPE_SPIFI_READ_EX` function.

`BusWidth` encodes the number of data lines to be used when transferring the command, address and data. The value can be decoded using `FS_BUSWIDTH_GET_CMD()`, `FS_BUSWIDTH_GET_ADDR()` and `FS_BUSWIDTH_GET_DATA()`. The dummy bytes are sent us-

ing the same number of data lines as the address. For additional information refer to *SPI bus width decoding* on page 704

6.4.5.3.7 FS_NOR_HW_TYPE_SPIFI_WRITE

Description

Transfers data from MCU to serial NOR flash.

Type definition

```
typedef void FS_NOR_HW_TYPE_SPIFI_WRITE(
    U8      Unit,
    U8      Cmd,
    const U8 * pPara,
    unsigned NumBytesPara,
    unsigned NumBytesAddr,
    const U8 * pData,
    unsigned NumBytesData,
    U16     BusWidth);
```

Parameters

Parameter	Description
<code>Unit</code>	Index of the hardware layer (0-based).
<code>Cmd</code>	Code of the command to be sent.
<code>pPara</code>	in Command parameters (address and dummy bytes). Can be NULL.
<code>NumBytesPara</code>	Total number of address and dummy bytes to be sent. Can be 0.
<code>NumBytesAddr</code>	Number of address bytes to be send. Can be 0.
<code>pData</code>	in Data to be sent to the serial NOR flash device. Can be NULL.
<code>NumBytesData</code>	Number of bytes to be written the serial NOR flash device. Can be 0.
<code>BusWidth</code>	Number of data lines to be used for the data transfer.

Additional information

This function is a member of the SPIFI NOR hardware layer API. The implementation of this function is not required if the hardware layer implements `FS_NOR_HW_TYPE_SPIFI_WRITE_EX`.

This function is called with the SPI hardware in command mode. Typically, the physical layer calls this function when it wants to modify the data in a page of the serial NOR flash device or to erase a NOR physical sector. `FS_NOR_HW_TYPE_SPIFI_WRITE` has to wait for the data transfer to complete before it returns.

The first address byte is stored at `*pPara`. `NumBytesAddr` is always smaller than or equal to `NumBytesPara`. If `NumBytesAddr` is equal to `NumBytesPara` then no additional data have to be sent. The number of additional bytes to be sent can be calculated as `NumBytesPara - NumBytesAddr`. This data has to be sent via the same number of data lines as the address.

`BusWidth` encodes the number of data lines to be used when transferring the command, address and data. The value can be decoded using `FS_BUSWIDTH_GET_CMD()`, `FS_BUSWIDTH_GET_ADDR()` and `FS_BUSWIDTH_GET_DATA()`. The dummy bytes are sent using the same number of data lines as the address. For additional information refer to *SPI bus width decoding* on page 704

6.4.5.3.8 FS_NOR_HW_TYPE_SPIFI_POLL

Description

Checks periodically the value of a status flag.

Type definition

```
typedef int FS_NOR_HW_TYPE_SPIFI_POLL(U8 Unit,
                                       U8 Cmd,
                                       U8 BitPos,
                                       U8 BitValue,
                                       U32 Delay,
                                       U32 TimeOut_ms,
                                       U16 BusWidth);
```

Parameters

Parameter	Description
<code>Unit</code>	Index of the hardware layer (0-based).
<code>Cmd</code>	Code of the command to be sent.
<code>BitPos</code>	Position of the bit to be checked.
<code>BitValue</code>	Value of the bit to wait for.
<code>Delay</code>	Number of clock cycles to wait between two queries.
<code>TimeOut_ms</code>	Maximum number of milliseconds to wait for the bit to be set.
<code>BusWidth</code>	Number of data lines to be used for the data transfer.

Return value

> 0 Timeout occurred.
 = 0 OK, bit set to specified value.
 < 0 Feature not supported.

Additional information

This function is a member of the SPIFI NOR hardware layer API. The implementation of this function is optional.

This function is called with the SPI hardware in command mode. `FS_NOR_HW_TYPE_SPIFI_POLL` has to wait for the NOR flash device to set a flag to a specified value. This has to be realized by periodically reading one byte from the serial NOR flash device via the specified command and by checking that the bit at `BitPos` in the read byte is set to the value specified by `BitValue`. A `BitPos` of 0 specifies the position of the least significant bit in the response.

`BusWidth` encodes the number of data lines to be used when transferring the command and data. The value can be decoded using `FS_BUSWIDTH_GET_CMD()`, and `FS_BUSWIDTH_GET_DATA()`. For additional information refer to *SPI bus width decoding* on page 704

6.4.5.3.9 FS_NOR_HW_TYPE_SPIFI_DELAY

Description

Blocks the execution for the specified time.

Type definition

```
typedef int FS_NOR_HW_TYPE_SPIFI_DELAY(U8 Unit,
                                       U32 ms);
```

Parameters

Parameter	Description
<code>Unit</code>	Index of the hardware layer (0-based).
<code>ms</code>	Number of milliseconds to block the execution.

Return value

= 0 OK, delay executed.
 < 0 Functionality not supported.

Additional information

This function is a member of the SPIFI NOR hardware layer API. The implementation of this function is optional. `FS_NOR_HW_TYPE_SPIFI_DELAY` can block the execution for longer than the number of milliseconds specified but not less than that. Typically, the function is implemented using a delay function of the used RTOS if any. If the hardware layer chooses not to implement `FS_NOR_HW_TYPE_SPIFI_DELAY` then the `pfDelay` member of `FS_NOR_HW_TYPE_SPIFI` can be set to `NULL` or to the address of a function that returns a negative value. If the function is not implemented by the hardware layer then the NOR physical layer blocks the execution by using a software loop. The number of software loops is calculated based in the SPI clock frequency returned by `FS_NOR_HW_TYPE_SPIFI_INIT`.

6.4.5.3.10 FS_NOR_HW_TYPE_SPIFI_LOCK

Description

Releases the exclusive access to SPI bus.

Type definition

```
typedef void FS_NOR_HW_TYPE_SPIFI_LOCK(U8 Unit);
```

Parameters

Parameter	Description
<code>Unit</code>	Index of the hardware layer (0-based).

Additional information

This function is a member of the SPIFI NOR hardware layer API. The implementation of this function is optional.

The NOR physical layer calls this function to indicate that it needs exclusive to access the NOR flash device via the SPI bus. It is guaranteed that the NOR physical layer does not attempt to exchange any data with the serial NOR flash device via the SPI bus before calling this function first. It is also guaranteed that `FS_NOR_HW_TYPE_SPIFI_LOCK` and `FS_NOR_HW_TYPE_SPIFI_UNLOCK` are called in pairs. Typically, this function is used for synchronizing the access to SPI bus when the SPI bus is shared between the serial NOR flash and other SPI devices.

A possible implementation would make use of an OS semaphore that is acquired in `FS_NOR_HW_TYPE_SPIFI_LOCK` and released in `FS_NOR_HW_TYPE_SPIFI_UNLOCK`.

6.4.5.3.11 FS_NOR_HW_TYPE_SPIFI_UNLOCK

Description

Requests exclusive access to SPI bus.

Type definition

```
typedef void FS_NOR_HW_TYPE_SPIFI_UNLOCK(U8 Unit);
```

Parameters

Parameter	Description
<code>Unit</code>	Index of the hardware layer (0-based).

Additional information

This function is a member of the SPIFI NOR hardware layer API. The implementation of this function is optional.

The NOR physical layer calls this function when it no longer needs to access the serial NOR flash device via the SPI bus. It is guaranteed that the NOR physical layer does not attempt to exchange any data with the serial NOR flash device via the SPI bus before calling `FS_NOR_HW_TYPE_SPIFI_LOCK`. It is also guaranteed that `FS_NOR_HW_TYPE_SPIFI_UNLOCK` and `FS_NOR_HW_TYPE_SPIFI_LOCK` are called in pairs.

`FS_NOR_HW_TYPE_SPIFI_UNLOCK` and `FS_NOR_HW_TYPE_SPIFI_LOCK` can be used to synchronize the access to the SPI bus when other devices than the serial NOR flash are connected to it. A possible implementation would make use of an OS semaphore that is acquired `FS_NOR_HW_TYPE_SPIFI_LOCK` and released in `FS_NOR_HW_TYPE_SPIFI_UNLOCK`.

6.4.5.3.12 FS_NOR_HW_TYPE_SPIFI_MAP_EX

Description

Configures the hardware for access to serial NOR flash via system memory.

Type definition

```
typedef int FS_NOR_HW_TYPE_SPIFI_MAP_EX(
    U8      Unit,
    const U8      * pCmd,
    unsigned NumBytesCmd,
    const U8      * pPara,
    unsigned NumBytesPara,
    unsigned NumBytesAddr,
    U16      BusWidth,
    unsigned Flags);
```

Parameters

Parameter	Description
<code>Unit</code>	Index of the hardware layer (0-based).
<code>pCmd</code>	in Code of the command to be used for reading the data. Cannot be <code>NULL</code> .
<code>NumBytesCmd</code>	Number of bytes in the command code. Cannot be 0.
<code>pPara</code>	in Command parameters (address and dummy bytes). Can be <code>NULL</code> .
<code>NumBytesPara</code>	Total number of address and dummy bytes to be sent. Can be 0.
<code>NumBytesAddr</code>	Number of address bytes to be send. Can be 0.
<code>BusWidth</code>	Number of data lines to be used for the data transfer.
<code>Flags</code>	Options for the data exchange.

Return value

= 0 OK, memory mode configured successfully.
 ≠ 0 An error occurred.

Additional information

This function is a member of the SPIFI NOR hardware layer API. The implementation of this function is optional. The function has to be implemented only by hardware layers that have to be able to transfer the data via eight data lines or in DTR mode. If the hardware layer does not implement this function then `FS_NOR_HW_TYPE_SPIFI_MAP` is called instead.

This function performs the same operation as `FS_NOR_HW_TYPE_SPIFI_MAP` with the difference that it can handle multi-byte commands and additional data transfer options received via `Flags`. `Flags` is a bitwise-or combination of *NOR HW layer flags* on page 947. In addition, this function is able to report an error via the return value.

6.4.5.3.13 FS_NOR_HW_TYPE_SPIFI_CONTROL_EX

Description

Sends a command to serial NOR flash that does not transfer any data.

Type definition

```
typedef int FS_NOR_HW_TYPE_SPIFI_CONTROL_EX(
    U8          Unit,
    const U8    * pCmd,
    unsigned    NumBytesCmd,
    U8          BusWidth,
    unsigned    Flags);
```

Parameters

Parameter	Description
<code>Unit</code>	Index of the hardware layer (0-based).
<code>pCmd</code>	in Code of the command to be sent. Cannot be NULL.
<code>NumBytesCmd</code>	Number of bytes in the command code. Cannot be 0.
<code>BusWidth</code>	Number of data lines to be used for sending the command.
<code>Flags</code>	Options for the data exchange.

Return value

= 0 OK, command transferred successfully.
 ≠ 0 An error occurred.

Additional information

This function is a member of the SPIFI NOR hardware layer API. The implementation of this function is optional. The function has to be implemented only by hardware layers that have to be able to transfer the data via eight data lines or in DTR mode. If the hardware layer does not implement this function then `FS_NOR_HW_TYPE_SPIFI_CONTROL` is called instead.

This function performs the same operation as `FS_NOR_HW_TYPE_SPIFI_CONTROL` with the difference that it can handle multi-byte commands and additional data transfer options specified via `Flags`. `Flags` is a bitwise-or combination of *NOR HW layer flags* on page 947. In addition, this function is able to report an error via the return value.

The value of `BusWidth` is not encoded as is the case with the other functions of this physical layer. The value specified via `BusWidth` is the actual number of data lines that have to be used for the data transfer of the command code. Permitted values are 1, 2, 4 and 8.

6.4.5.3.14 FS_NOR_HW_TYPE_SPIFI_READ_EX

Description

Transfers data from serial NOR flash to MCU.

Type definition

```
typedef int FS_NOR_HW_TYPE_SPIFI_READ_EX(
    Unit,
    const U8 * pCmd,
    unsigned NumBytesCmd,
    const U8 * pPara,
    unsigned NumBytesPara,
    unsigned NumBytesAddr,
    U8 * pData,
    unsigned NumBytesData,
    U16 BusWidth,
    unsigned Flags);
```

Parameters

Parameter	Description
<code>Unit</code>	Index of the hardware layer (0-based).
<code>pCmd</code>	in Code of the command to be sent. Cannot be NULL.
<code>NumBytesCmd</code>	Number of bytes in the command code. Cannot be 0.
<code>pPara</code>	in Command parameters (address and dummy bytes). Can be NULL.
<code>NumBytesPara</code>	Total number of address and dummy bytes to be sent. Can be 0.
<code>NumBytesAddr</code>	Number of address bytes to be send. Can be 0.
<code>pData</code>	out Data read from the serial NOR flash device. Can be NULL.
<code>NumBytesData</code>	Number of bytes to read from the serial NOR flash device. Can be 0.
<code>BusWidth</code>	Number of data lines to be used for the data transfer.
<code>Flags</code>	Options for the data exchange.

Return value

= 0 OK, data transferred successfully.
 ≠ 0 An error occurred.

Additional information

This function is a member of the SPIFI NOR hardware layer API. The implementation of this function is optional. The function has to be implemented only by hardware layers that have to be able to transfer the data via eight data lines or in DTR mode. If the hardware layer does not implement this function then `FS_NOR_HW_TYPE_SPIFI_READ` is called instead.

The first address byte is stored at `*pPara`. `NumBytesAddr` is always smaller than or equal to `NumBytesPara`. If `NumBytesAddr` is equal to `NumBytesPara` then neither mode nor dummy bytes have to be sent. The number of mode bytes is always one and is indicated by `FS_NOR_HW_FLAG_MODE_BYTE` being set in `Flags`. The value of the mode byte is located at `*(pPara + NumBytesAddr)`. The number of dummy bytes to be generated can be calculated as `NumBytesPara - NumBytesAddr`. If `FS_NOR_HW_FLAG_MODE_BYTE` is set in `Flags` then one has to be subtracted from the calculate value. One additional dummy nibble (half-byte) has to be generated if `FS_NOR_HW_FLAG_DUMMY_NIBBLE` is set in `Flags`. If the hardware generates dummy cycles instead of bytes then the number of dummy bytes has to converted to clock cycles by taking into account the number of data lines used for the data transfer of the address.

This function performs the same operation as `FS_NOR_HW_TYPE_SPIFI_READ` with the difference that it can handle multi-byte commands and additional data transfer options specified via `Flags`. `Flags` is a bitwise-or combination of *NOR HW layer flags* on page 947. In addition, this function is able to report an error via the return value.

6.4.5.3.15 FS_NOR_HW_TYPE_SPIFI_WRITE_EX

Description

Transfers data from MCU to serial NOR flash.

Type definition

```
typedef int FS_NOR_HW_TYPE_SPIFI_WRITE_EX(
    U8      Unit,
    const U8 * pCmd,
    unsigned NumBytesCmd,
    const U8 * pPara,
    unsigned NumBytesPara,
    unsigned NumBytesAddr,
    const U8 * pData,
    unsigned NumBytesData,
    U16     BusWidth,
    unsigned Flags);
```

Parameters

Parameter	Description
<code>Unit</code>	Index of the hardware layer (0-based).
<code>pCmd</code>	in Code of the command to be sent. Cannot be NULL.
<code>NumBytesCmd</code>	Number of bytes in the command code. Cannot be 0.
<code>pPara</code>	in Command parameters (address and dummy bytes). Can be NULL.
<code>NumBytesPara</code>	Total number of address and dummy bytes to be sent. Can be 0.
<code>NumBytesAddr</code>	Number of address bytes to be send. Can be 0.
<code>pData</code>	in Data to be sent to the serial NOR flash device. Can be NULL.
<code>NumBytesData</code>	Number of bytes to be written the serial NOR flash device. Can be 0.
<code>BusWidth</code>	Number of data lines to be used for the data transfer.
<code>Flags</code>	Options for the data exchange.

Return value

= 0 OK, data transferred successfully.
 ≠ 0 An error occurred.

Additional information

This function is a member of the SPIFI NOR hardware layer API. The implementation of this function is optional. The function has to be implemented only by hardware layers that have to be able to transfer the data via eight data lines or in DTR mode. If the hardware layer does not implement this function then `FS_NOR_HW_TYPE_SPIFI_WRITE` is called instead.

This function performs the same operation as `FS_NOR_HW_TYPE_SPIFI_WRITE` with the difference that it can handle multi-byte commands and additional data transfer options specified via `Flags`. `Flags` is a bitwise-or combination of *NOR HW layer flags* on page 947. In addition, this function is able to report an error via the return value.

6.4.5.3.16 FS_NOR_HW_TYPE_SPIFI_POLL_EX

Description

Checks periodically the value of a status flag.

Type definition

```
typedef int FS_NOR_HW_TYPE_SPIFI_POLL_EX(
    U8          Unit,
    const U8    * pCmd,
    unsigned    NumBytesCmd,
    const U8    * pPara,
    unsigned    NumBytesPara,
    unsigned    NumBytesAddr,
    U8          BitPos,
    U8          BitValue,
    U32         Delay,
    U32         TimeOut_ms,
    U16         BusWidth,
    unsigned    Flags);
```

Parameters

Parameter	Description
<code>Unit</code>	Index of the hardware layer (0-based).
<code>pCmd</code>	in Code of the command to be sent. Cannot be NULL.
<code>NumBytesCmd</code>	Number of bytes in the command code. Cannot be 0.
<code>pPara</code>	in Command parameters (address and dummy bytes). Can be NULL.
<code>NumBytesPara</code>	Total number of address and dummy bytes to be sent. Can be 0.
<code>NumBytesAddr</code>	Number of address bytes to be send. Can be 0.
<code>BitPos</code>	Position of the bit to be checked.
<code>BitValue</code>	Value of the bit to wait for.
<code>Delay</code>	Number of clock cycles to wait between two queries.
<code>TimeOut_ms</code>	Maximum number of milliseconds to wait for the bit to be set.
<code>BusWidth</code>	Number of data lines to be used for the data transfer.
<code>Flags</code>	Options for the data exchange.

Return value

> 0 Timeout occurred.
 = 0 OK, bit set to specified value.
 < 0 Feature not supported.

Additional information

This function is a member of the SPIFI NOR hardware layer API. The implementation of this function is optional. The function has to be implemented only by hardware layers that have to be able to transfer the data of the polling command via eight data lines or in DTR mode. If the hardware layer does not implement this function then `FS_NOR_HW_TYPE_SPIFI_POLL` is called instead.

This function performs the same operation as `FS_NOR_HW_TYPE_SPIFI_POLL` with the difference that it can handle multi-byte commands and additional data transfer options specified via `Flags`. `Flags` is a bitwise-or combination of *NOR HW layer flags* on page 947. In addition, this function is able to report an error via the return value.

6.4.5.3.17 NOR HW layer flags

Description

Additional options for data exchanged by the SPI NOR HW layers.

Definition

```
#define FS_NOR_HW_FLAG_DTR_DATA      (1uL << 0)
#define FS_NOR_HW_FLAG_DTR_ADDR     (1uL << 1)
#define FS_NOR_HW_FLAG_DTR_CMD      (1uL << 2)
#define FS_NOR_HW_FLAG_DQS_ACTIVE   (1uL << 3)
#define FS_NOR_HW_FLAG_DQS_INVERTED (1uL << 4)
#define FS_NOR_HW_FLAG_DTR_D1_D0    (1uL << 5)
#define FS_NOR_HW_FLAG_ADDR_3BYTE   (1uL << 6)
#define FS_NOR_HW_FLAG_DUMMY_4BIT   (1uL << 7)
#define FS_NOR_HW_FLAG_DUMMY_2BIT   (1uL << 8)
#define FS_NOR_HW_FLAG_DUMMY_1BIT   (1uL << 9)
#define FS_NOR_HW_FLAG_MODE_8BIT    (1uL << 10)
#define FS_NOR_HW_FLAG_MODE_4BIT    (1uL << 11)
#define FS_NOR_HW_FLAG_MODE_2BIT    (1uL << 12)
#define FS_NOR_HW_FLAG_MODE_1BIT    (1uL << 13)
```

Symbols

Definition	Description
FS_NOR_HW_FLAG_DTR_DATA	Exchange the data on each clock transition.
FS_NOR_HW_FLAG_DTR_ADDR	Send the address on each clock transition.
FS_NOR_HW_FLAG_DTR_CMD	Send the command on each clock transition.
FS_NOR_HW_FLAG_DQS_ACTIVE	Enable the data strobe signal.
FS_NOR_HW_FLAG_DQS_INVERTED	Data strobe signal is inverted in reference to clock signal.
FS_NOR_HW_FLAG_DTR_D1_D0	Send odd-numbered bytes on the rising edge of the clock signal.
FS_NOR_HW_FLAG_ADDR_3BYTE	Send a 3-byte address to NOR flash device.
FS_NOR_HW_FLAG_DUMMY_4BIT	Generate additional dummy cycles equivalent to four bits of data.
FS_NOR_HW_FLAG_DUMMY_2BIT	Generate additional dummy cycles equivalent to two bits of data.
FS_NOR_HW_FLAG_DUMMY_1BIT	Generate additional dummy cycles equivalent to one bit of data.
FS_NOR_HW_FLAG_MODE_8BIT	Send eight mode bits after the data address.
FS_NOR_HW_FLAG_MODE_4BIT	Send four mode bits after the data address.
FS_NOR_HW_FLAG_MODE_2BIT	Send two mode bits after the data address.
FS_NOR_HW_FLAG_MODE_1BIT	Send one mode bit after the data address.

6.4.5.3.18 Sample implementation

The following sample implementation uses the SPIFI controller of an NXP LPC4322 MCU to interface with a serial NOR flash device. This NOR hardware layer has been tested on a SGGGER internal test board.

```

/*****
*                               (c) SEGGER Microcontroller GmbH                               *
*                               The Embedded Experts                                       *
*                               www.segger.com                                           *
*****/

----- END-OF-HEADER -----

File   : NOR_PHY_SPIFI_NXP_LPC4322_SEGGER_QSPIFI_Test_Board.c
Purpose : Low-level flash driver for NXP SPIFI interface.
Literature:
  [1] UM10503 LPC43xx ARM Cortex-M4/M0 multi-core microcontroller
*/

/*****
*
*   #include section
*
*****/
#include "FS.h"

/*****
*
*   Defines, configurable
*
*****/
#define SPIFI_CLK_HZ          60000000uL
// Frequency of the clock supplied to SPIFI unit.
#define SPIFI_DATA_ADDR      0x80000000
// This is the start address of the memory region used by the file system

// to read the data from the serial NOR flash device. The hardware layer
// performs a dummy read from this address when switching to memory mode
// in order to clean the caches. It should be set to the value passed

// as second parameter to FS_NOR_Configure()/FS_NOR_BM_Configure() in FS_X_AddDevices().
#define RESET_DELAY_LOOPS    100000
// Number of software loops to wait for NOR device to reset
#define USE_OS                0
// Enables / disables the interrupt driver operation

/*****
*
*   #include section, conditional
*
*****/
#if USE_OS
#include "RTOS.h"
#include "lpc43xx.h"
#endif

/*****
*
*   Defines, fixed
*
*****/

/*****
*
*   SPIFI unit
*
*****/
#define SPIFI_BASE_ADDR      0x40003000

```

```

#define SPIFI_CTRL      (*(volatile U32*)(SPIFI_BASE_ADDR + 0x00))
// SPIFI control register
#define SPIFI_CMD       (*(volatile U32*)(SPIFI_BASE_ADDR + 0x04))
// SPIFI command register
#define SPIFI_ADDR     (*(volatile U32*)(SPIFI_BASE_ADDR + 0x08))
// SPIFI address register
#define SPIFI_IDATA    (*(volatile U32*)(SPIFI_BASE_ADDR + 0x0C))
// SPIFI intermediate data register
#define SPIFI_CLIMIT   (*(volatile U32*)(SPIFI_BASE_ADDR + 0x10))
// SPIFI cache limit register
#define SPIFI_DATA32   (*(volatile U32*)(SPIFI_BASE_ADDR + 0x14))
// SPIFI data register (32-bit access, 4 bytes at once)
#define SPIFI_DATA16   (*(volatile U16*)(SPIFI_BASE_ADDR + 0x14))
// SPIFI data register (16-bit access, 2 bytes at once)
#define SPIFI_DATA8    (*(volatile U8*)(SPIFI_BASE_ADDR + 0x14))
// SPIFI data register (8-bit access, 1 byte at once)
#define SPIFI_MCMD     (*(volatile U32*)(SPIFI_BASE_ADDR + 0x18))
// SPIFI memory command register
#define SPIFI_STAT     (*(volatile U32*)(SPIFI_BASE_ADDR + 0x1C))
// SPIFI status register

/*****
*
*       Clock generation unit
*/
#define CGU_BASE_ADDR      0x40050000
#define IDIVA_CTRL        (*(volatile U32*)(CGU_BASE_ADDR + 0x0048))
#define IDIVB_CTRL        (*(volatile U32*)(CGU_BASE_ADDR + 0x004C))
#define BASE_SPIFI_CLK    (*(volatile U32*)(CGU_BASE_ADDR + 0x0070))

/*****
*
*       Clock control unit 1
*/
#define CCU1_BASE_ADDR    0x40051000
#define CLK_SPIFI_CFG     (*(volatile U32*)(CCU1_BASE_ADDR + 0x0300))
#define CLK_SPIFI_STAT    (*(volatile U32*)(CCU1_BASE_ADDR + 0x0304))

/*****
*
*       System control unit
*/
#define SCU_BASE_ADDR    0x40086000
#define SFSP3_2          (*(volatile U32*)(SCU_BASE_ADDR + 0x188))
// Pin configuration register for pin P3_2
#define SFSP3_3          (*(volatile U32*)(SCU_BASE_ADDR + 0x18C))
// Pin configuration register for pin P3_3
#define SFSP3_4          (*(volatile U32*)(SCU_BASE_ADDR + 0x190))
// Pin configuration register for pin P3_4
#define SFSP3_5          (*(volatile U32*)(SCU_BASE_ADDR + 0x194))
// Pin configuration register for pin P3_5
#define SFSP3_6          (*(volatile U32*)(SCU_BASE_ADDR + 0x198))
// Pin configuration register for pin P3_6
#define SFSP3_7          (*(volatile U32*)(SCU_BASE_ADDR + 0x19C))
// Pin configuration register for pin P3_7
#define SFSP3_8          (*(volatile U32*)(SCU_BASE_ADDR + 0x1A0))
// Pin configuration register for pin P3_8

/*****
*
*       GPIO unit
*/
#define GPIO_BASE_ADDR    0x400F4000
#define GPIO_DIR5         (*(volatile U32*)(GPIO_BASE_ADDR + 0x2014))
// Direction registers port 5
#define GPIO_SET5         (*(volatile U32*)(GPIO_BASE_ADDR + 0x2214))
// Set register for port 5
#define GPIO_CLR5         (*(volatile U32*)(GPIO_BASE_ADDR + 0x2294))
// Clear register for port 5

/*****
*
*       SPIFI command register
*/
#define CMD_BITPOS_BIT    0
#define CMD_BITPOS_MASK  0x7uL

```

```

#define CMD_BITVAL_BIT          3
#define CMD_BITVAL_MASK        0x1uL
#define CMD_DATALEN_BIT        0
#define CMD_DATALEN_MASK      0x3FFFuL
#define CMD_POLL_BIT           14
#define CMD_DOUT_BIT           15
#define CMD_INTLEN_BIT         16
#define CMD_INTLEN_MASK       0x7uL
#define CMD_FIELDFORM_BIT      19
#define CMD_FIELDFORM_ALL_SERIAL 0x0uL
#define CMD_FIELDFORM_QUAD_DUAL_DATA 0x1uL
#define CMD_FIELDFORM_SERIAL_OPCODE 0x2uL
#define CMD_FIELDFORM_ALL_QUAD_DUAL 0x3uL
#define CMD_FRAMEFORM_BIT      21
#define CMD_FRAMEFORM_OPCODE   0x1uL
#define CMD_FRAMEFORM_OPCODE_1BYTE 0x2uL
#define CMD_FRAMEFORM_OPCODE_2BYTES 0x3uL
#define CMD_FRAMEFORM_OPCODE_3BYTES 0x4uL
#define CMD_FRAMEFORM_OPCODE_4BYTES 0x5uL
#define CMD_OPCODE_BIT         24
#define CMD_OPCODE_MASK       0xFFuL

/*****
 *
 *     SPIFI control register
 */
#define CTRL_TIMEOUT_BIT        0
#define CTRL_CSHIGH_BIT        16
#define CTRL_D_PRFTCH_DIS_BIT  21
#define CTRL_MODE3_BIT         23
#define CTRL_INTEN_BIT         22
#define CTRL_PRFTCH_DIS_BIT    27
#define CTRL_DUAL_BIT          28
#define CTRL_FBCLK_BIT         30

/*****
 *
 *     SPIFI status register
 */
#define STAT_MCINIT_BIT        0
#define STAT_CMD_BIT           1
#define STAT_RESET_BIT         4
#define STAT_INTRQ_BIT         5

/*****
 *
 *     Misc. defines
 */
#define CGU_IDIV_BIT           2
#define CGU_AUTOBLOCK_BIT     11
#define CGU_CLK_SEL_BIT        24
#define SFS_MODE_BIT           0
#define SFS_EPUN_BIT           4
#define SFS_EHS_BIT            5
#define SFS_EZI_BIT            6
#define SFS_ZIF_BIT            7
#define CLK_STAT_RUN_BIT       0
#define CLK_CFG_RUN_BIT        0
#define NOR_RESET_BIT          9
#define SPIFI_PRIO             15

/*****
 *
 *     ASSERT_IS_LOCKED
 */
#if FS_SUPPORT_TEST
    #define ASSERT_IS_LOCKED() \
        if (_LockCnt != 1) { \
            FS_X_PANIC(FS_ERRCODE_INVALID_USAGE); \
        }
#else
    #define ASSERT_IS_LOCKED()
#endif

/*****
 *

```

```

*       IF_TEST
*/
#if FS_SUPPORT_TEST
#define IF_TEST(Expr)      Expr
#else
#define IF_TEST(Expr)
#endif

/*****
*
*       Static data
*
*****/
*/
#if FS_SUPPORT_TEST
static U8 _LockCnt = 0;
// Just to test if the Lock()/Unlock function are called correctly.
#endif

/*****
*
*       Static code
*
*****/
*/

/*****
*
*       _GetFieldForm
*
*       Function description
*       Determines the value to be stored in the FIELDFORM field
*       of the SPIFI_CMD and SPIFI_MCMD registers. It also returns
*       the value of the SPIFI_CTRL.DUAL field.
*/
static U32 _GetFieldForm(U16 BusWidth, int * pIsDual) {
    U32 FieldForm;
    int IsDual;

    IsDual = 0;
    if (BusWidth == 0x112u) {
        FieldForm = CMD_FIELDFORM_QUAD_DUAL_DATA;
        // Data field is dual other fields are serial.
        IsDual = 1;
    } else if (BusWidth == 0x114u) {
        FieldForm = CMD_FIELDFORM_QUAD_DUAL_DATA;
        // Data field is quad other fields are serial.
    } else if (BusWidth == 0x122u) {
        FieldForm = CMD_FIELDFORM_SERIAL_OPCODE;
        // Opcode field is serial. Other fields are dual.
        IsDual = 1;
    } else if (BusWidth == 0x144u) {
        FieldForm = CMD_FIELDFORM_SERIAL_OPCODE;
        // Opcode field is serial. Other fields are quad.
    } else if (BusWidth == 0x444u) {
        FieldForm = CMD_FIELDFORM_ALL_QUAD_DUAL;
        // Opcode field is serial. Other fields are quad.
    } else {
        FieldForm = CMD_FIELDFORM_ALL_SERIAL; // All fields of the command are serial.
    }
    if (pIsDual) {
        *pIsDual = IsDual;
    }
    return FieldForm;
}

/*****
*
*       _GetFieldFormEx
*
*       Function description
*       Same functionality as _GetFieldForm() with BusWidth not encoded.
*/
static U32 _GetFieldFormEx(U8 BusWidth, int * pIsDual) {
    U32 FieldForm;
    int IsDual;

```

```

IsDual = 0;
if (BusWidth == 1) {
    FieldForm = CMD_FIELDFORM_ALL_SERIAL;        // All fields of the command are serial.
} else if (BusWidth == 2) {
    FieldForm = CMD_FIELDFORM_ALL_QUAD_DUAL;    // All fields are dual.
    IsDual = 1;
} else if (BusWidth == 4) {
    FieldForm = CMD_FIELDFORM_ALL_QUAD_DUAL;    // All fields are quad.
} else {
    FieldForm = CMD_FIELDFORM_ALL_SERIAL;        // All fields of the command are serial.
}
if (pIsDual) {
    *pIsDual = IsDual;
}
return FieldForm;
}

/*****
 *
 *      _GetFrameForm
 *
 * Function description
 * Determines the value to be stored in the FAMEFORM field
 * of the SPIFI_CMD and SPIFI_MCMD registers.
 */
static U32 _GetFrameForm(unsigned NumBytesAddr) {
    U32 FrameForm;

    if (NumBytesAddr == 1) {
        FrameForm = CMD_FRAMEFORM_OPCODE_1BYTE;    // Opcode + 1 address byte.
    } else if (NumBytesAddr == 2) {
        FrameForm = CMD_FRAMEFORM_OPCODE_2BYTES;  // Opcode + 2 address bytes.
    } else if (NumBytesAddr == 3) {
        FrameForm = CMD_FRAMEFORM_OPCODE_3BYTES;  // Opcode + 3 address bytes.
    } else if (NumBytesAddr == 4) {
        FrameForm = CMD_FRAMEFORM_OPCODE_4BYTES;  // Opcode + 4 address bytes.
    } else {
        FrameForm = CMD_FRAMEFORM_OPCODE;         // Opcode, no address bytes.
    }
    return FrameForm;
}

/*****
 *
 *      _Reset
 */
static void _Reset(void) {
    SPIFI_STAT = (1uL << STAT_RESET_BIT);
    // Reset the SPIFI controller. The controller is put into SPI mode.
    while (1) {
        if ((SPIFI_STAT & ((1uL << STAT_CMD_BIT) |
                           (1uL << STAT_RESET_BIT) |
                           (1uL << STAT_MCINIT_BIT))) == 0) {
            break;
        }
        // Wait until the SPIFI controller is ready again.
    }
}

/*****
 *
 *      Public code
 */
#if USE_OS

/*****
 *
 *      SPIFI_IRQHandler
 */
void SPIFI_IRQHandler(void);
void SPIFI_IRQHandler(void) {
    OS_EnterInterrupt();
}

```



```

SPIFI_STAT |= 1uL << STAT_INTRQ_BIT;           // Prevent other interrupts from occurring.
FS_X_OS_Signal();
OS_LeaveInterrupt();
}

#endif

/*****
 *
 *   Public code (via callback)
 *
 *****/

/*****
 *
 *   _HW_Init
 *
 *   Function description
 *   HW layer function. It is called before any other function of the physical layer.
 *   It should configure the HW so that the other functions can access the NOR flash.
 *
 *   Return value
 *   Frequency of the SPI clock in Hz.
 */
static int _HW_Init(U8 Unit) {
    unsigned NumLoops;

    FS_USE_PARA(Unit);    // This device has only one HW unit.
    //
    // Use IDIVA as clock for SPIFI. The input of IDIVA is PLL1.
    //
    IDIVA_CTRL          = 0
                        | (9uL << CGU_CLK_SEL_BIT)    // Use PLL1 as input
                        | (2uL << CGU_IDIV_BIT)      // Divide PLL1 by 3
                        | (1uL << CGU_AUTOBLOCK_BIT)
                        ;

    BASE_SPIFI_CLK      = 0
                        | 12uL << CGU_CLK_SEL_BIT    // Use IDIVA as clock generator
                        | 1uL << CGU_AUTOBLOCK_BIT
                        ;

    //
    // Enable the SPIFI clock if required.
    //
    if ((CLK_SPIFI_STAT & (1uL << CLK_STAT_RUN_BIT)) == 0) {
        CLK_SPIFI_CFG |= (1uL << CLK_CFG_RUN_BIT);
        while (1) {
            if (CLK_SPIFI_STAT & (1uL << CLK_CFG_RUN_BIT)) {
                ;
            }
        }
    }
    //
    // Clock pin.
    //
    SFSP3_3 = 0
            | (3uL << SFS_MODE_BIT)
            | (1uL << SFS_EPUN_BIT)
            | (1uL << SFS_EHS_BIT)
            | (1uL << SFS_EZI_BIT)
            ;

    //
    // Data pins.
    //
    SFSP3_4 = 0
            | (3uL << SFS_MODE_BIT)
            | (1uL << SFS_EPUN_BIT)
            | (1uL << SFS_EZI_BIT)
            ;

    SFSP3_5 = 0
            | (3uL << SFS_MODE_BIT)
            | (1uL << SFS_EPUN_BIT)
            | (1uL << SFS_EZI_BIT)
            ;

    SFSP3_6 = 0
            | (3uL << SFS_MODE_BIT)

```

```

        | (1uL << SFS_EPUN_BIT)
        | (1uL << SFS_EZI_BIT)
        ;
SFSP3_7 = 0
        | (3uL << SFS_MODE_BIT)
        | (1uL << SFS_EPUN_BIT)
        | (1uL << SFS_EZI_BIT)
        ;

//
// Chip select pin.
//
SFSP3_8 = 0
        | (3uL << SFS_MODE_BIT)           // Controlled by this HW layer.
        | (1uL << SFS_EPUN_BIT)
        ;

//
// Reset pin. Present only on 16-pin devices.
//
SFSP3_2 = 0
        | (4uL << SFS_MODE_BIT)           // Controlled by this HW layer.
        | (1uL << SFS_EPUN_BIT)
        ;

GPIO_DIR5 |= 1uL << NOR_RESET_BIT;
//
// Reset the NOR device.
//
GPIO_CLR5 = 1uL << NOR_RESET_BIT;           // Assert reset signal (active low).
NumLoops = RESET_DELAY_LOOPS;
do {
    ;
} while (--NumLoops);
GPIO_SET5 = 1uL << NOR_RESET_BIT;           // De-assert reset signal (active low).
#if USE_OS
//
// Disable the interrupt and configure the priority.
//
NVIC_DisableIRQ(SPIFI_IRQn);
NVIC_SetPriority(SPIFI_IRQn, SPIFI_PRIO);
#endif
//
// Configure the SPIFI unit.
//
SPIFI_CTRL = 0
        | (0xFFFFuL << CTRL_TIMEOUT_BIT) // Use the maximum timeout.
        | (0xFuL << CTRL_CSHIGH_BIT)
// Set minimum CS high time to maximum value.
        | (0x1uL << CTRL_D_PRFTCH_DIS_BIT) // Disable memory prefetches.
        | (0x1uL << CTRL_MODE3_BIT)       // CLK idle mode is high.
        | (0x1uL << CTRL_PRFTCH_DIS_BIT) // Disables prefetching of cache lines.
        | (0x1uL << CTRL_FBCLK_BIT)
// Read data is sampled using a feedback clock from the SCK pin.
        ;
#if USE_OS
//
// Clear interrupt flag.
//
SPIFI_STAT = 1uL << STAT_INTRQ_BIT;
NVIC_EnableIRQ(SPIFI_IRQn);
#endif
return SPIFI_CLK_HZ;
}

/*****
*
*     _HW_SetCmdMode
*
* Function description
* HW layer function. It enables the direct access to NOR flash via SPI.
* This function disables the memory-mapped mode.
*/
static void _HW_SetCmdMode(U8 Unit) {
    ASSERT_IS_LOCKED();
    FS_USE_PARA(Unit);           // This device has only one HW unit.
    _Reset();
}

```

```

/*****
 *
 *      _HW_SetMemMode
 *
 * Function description
 * HW layer function. It enables the memory-mapped mode. In this mode
 * the data can be accessed by doing read operations from memory.
 * The HW is responsible to transfer the data via SPI.
 * This function disables the direct access to NOR flash via SPI.
 */
static void _HW_SetMemMode(U8 Unit, U8 ReadCmd, unsigned NumBytesAddr, unsigned NumBytesDummy, U16 BusWidth)
{
    U32 FieldForm;
    U32 FrameForm;
    U32 OpCode;
    U32 IntLen;
    int IsDual;
    U32 MCmdReg;
    U32 v;

    ASSERT_IS_LOCKED();
    FS_USE_PARA(Unit); // This device has only one HW unit.
    //
    // Determine how the data transferred is sent (serial, dual or quad)
    // and how many address bytes to send.
    //
    IsDual = 0;
    FieldForm = _GetFieldForm(BusWidth, &IsDual);
    FrameForm = _GetFrameForm(NumBytesAddr);
    IntLen = NumBytesAddr & CMD_INTLEN_MASK;
    OpCode = ReadCmd & CMD_OPCODE_MASK;
    MCmdReg = 0
                | (IntLen << CMD_INTLEN_BIT)
                | (FieldForm << CMD_FIELDFORM_BIT)
                | (FrameForm << CMD_FRAMEFORM_BIT)
                | (OpCode << CMD_OPCODE_BIT)
                ;

    //
    // Configure the SPIFI controller to work in memory-mapped mode.
    //
    v = SPIFI_CTRL;
    if (IsDual) {
        v |= 1uL << CTRL_DUAL_BIT;
    } else {
        v &= ~(1uL << CTRL_DUAL_BIT);
    }
    SPIFI_CTRL = v;
    SPIFI_MCMD = MCmdReg;
    //
    // Wait until MCMD is written
    //
    while (1) {
        if (SPIFI_STAT & (1uL << STAT_MCINIT_BIT)) {
            break;
        }
    }
    //
    // Perform dummy read to bring controller into sync and invalidate all caches etc.
    // It seems to be necessary but not documented in the datasheet.
    //
    *(volatile U32*)SPIFI_DATA_ADDR;
}

/*****
 *
 *      _HW_ExecCmd
 *
 * Function description
 * HW layer function. It requests the NOR flash to execute a simple command.
 * The HW has to be in SPI mode.
 */
static void _HW_ExecCmd(U8 Unit, U8 Cmd, U8 BusWidth) {
    U32 FieldForm;
    int IsDual;
    U32 FrameForm;
    U32 CmdReg;
    U32 v;

```

```

ASSERT_IS_LOCKED();
FS_USE_PARA(Unit);    // This device has only one HW unit.
IsDual    = 0;
FieldForm = _GetFieldFormEx(BusWidth, &IsDual);
FrameForm = _GetFrameForm(0);    // 0 - No address bytes are sent.
CmdReg    = 0
           | (FieldForm << CMD_FIELDFORM_BIT)    // Configure the transfer mode.
           | (FrameForm << CMD_FRAMEFORM_BIT)    // Send only the command byte.
           | ((U32)Cmd << CMD_OPCODE_BIT)    // Command code.
           ;
v = SPIFI_CTRL;
if (IsDual) {
    v |= 1uL << CTRL_DUAL_BIT;
} else {
    v &= ~(1uL << CTRL_DUAL_BIT);
}
SPIFI_CTRL = v;
SPIFI_CMD  = CmdReg;
//
// Wait until nCS is set high, indicating that the command has been completed.
//
while (1) {
    if ((SPIFI_STAT & (1uL << STAT_CMD_BIT)) == 0) {
        break;
    }
}
}

/*****
 *
 *      _HW_ReadData
 *
 * Function description
 * HW layer function. It transfers data from NOR flash to MCU.
 * The HW has to be in SPI mode.
 */
static void _HW_ReadData(U8 Unit, U8 Cmd, const U8 * pPara, unsigned NumBytesPara, unsigned NumBytesAddr, U8
U32    DataLen;
U32    AddrReg;
U32    IDataReg;
U32    CmdReg;
U32    FieldForm;
int    IsDual;
U32    FrameForm;
U32    IntLen;
unsigned NumBytes;
U32    v;

ASSERT_IS_LOCKED();
FS_USE_PARA(Unit);    // This device has only one HW unit.
//
// Fill local variables.
//
IsDual    = 0;
FieldForm = _GetFieldForm(BusWidth, &IsDual);
FrameForm = _GetFrameForm(NumBytesAddr);
IntLen    = 0;
DataLen   = NumBytesData & CMD_DATALEN_MASK;
AddrReg   = 0;
IDataReg  = 0;
//
// Encode the address.
//
if (NumBytesAddr) {
    NumBytes = NumBytesAddr;
    do {
        AddrReg <<= 8;
        AddrReg |= (U32)(*pPara++);
    } while (--NumBytes);
}
//
// Encode the dummy and mode bytes.
//
if (NumBytesPara > NumBytesAddr) {
    NumBytes = NumBytesPara - NumBytesAddr;

```

```

    IntLen    = NumBytes;
    do {
        IDataReg <<= 8;
        IDataReg |= (U32)(*pPara++);
    } while (--NumBytes);
}
CmdReg = 0
    | (DataLen    << CMD_DATALEN_BIT)
    | (IntLen     << CMD_INTLEN_BIT)
    | (FieldForm << CMD_FIELDFORM_BIT)
    | (FrameForm << CMD_FRAMEFORM_BIT)
    | ((U32)Cmd  << CMD_OPCODE_BIT)
;

//
// Set dual/quad mode.
//
v = SPIFI_CTRL;
if (IsDual) {
    v |= 1uL << CTRL_DUAL_BIT;
} else {
    v &= ~(1uL << CTRL_DUAL_BIT);
}
SPIFI_CTRL = v;
//
// Execute the command.
//
SPIFI_ADDR = AddrReg;
SPIFI_IDATA = IDataReg;
SPIFI_CMD  = CmdReg;
//
// Read data from NOR flash.
//
if (NumBytesData) {
    do {
        *pData++ = SPIFI_DATA8;
    } while (--NumBytesData);
}
//
// Wait until nCS is set high, indicating that the command has been completed.
//
while (1) {
    if ((SPIFI_STAT & (1uL << STAT_CMD_BIT)) == 0) {
        break;
    }
}
}

/*****
*
*     _HW_WriteData
*
* Function description
* HW layer function. It transfers data from MCU to NOR flash.
* The HW has to be in SPI mode.
*/
static void _HW_WriteData(U8 Unit, U8 Cmd, const U8 * pPara, unsigned NumBytesPara, unsigned NumBytesAddr, c
U32    DataLen;
U32    AddrReg;
U32    IDataReg;
U32    FieldForm;
int     IsDual;
U32    FrameForm;
U32    IntLen;
unsigned NumBytesAtOnce;
unsigned NumBytes;
U32    v;
U32    CmdReg;

ASSERT_IS_LOCKED();
FS_USE_PARA(Unit); // This device has only one HW unit.
//
// Fill local variables.
//
IsDual    = 0;
FieldForm = _GetFieldForm(BusWidth, &IsDual);
FrameForm = _GetFrameForm(NumBytesAddr);

```

```

IntLen      = 0;
DataLen     = NumBytesData & CMD_DATALEN_MASK;
AddrReg     = 0;
IDataReg    = 0;
//
// Encode the address.
//
if (NumBytesAddr) {
    NumBytes = NumBytesAddr;
    do {
        AddrReg <<= 8;
        AddrReg |= (U32)(*pPara++);
    } while (--NumBytes);
}
//
// Encode the dummy and mode bytes.
//
if (NumBytesPara > NumBytesAddr) {
    NumBytes = NumBytesPara - NumBytesAddr;
    IntLen   = NumBytes;
    do {
        IDataReg <<= 8;
        IDataReg |= (U32)(*pPara++);
    } while (--NumBytes);
}
CmdReg = 0
        | (DataLen << CMD_DATALEN_BIT)
        | (1uL << CMD_DOUT_BIT) // Transfer data to NOR flash
        | (IntLen << CMD_INTLEN_BIT)
        | (FieldForm << CMD_FIELDFORM_BIT)
        | (FrameForm << CMD_FRAMEFORM_BIT)
        | ((U32)Cmd << CMD_OPCODE_BIT)
        ;

//
// Set dual/quad mode.
//
v = SPIFI_CTRL;
if (IsDual) {
    v |= 1uL << CTRL_DUAL_BIT;
} else {
    v &= ~(1uL << CTRL_DUAL_BIT);
}
SPIFI_CTRL = v;
//
// Execute the command.
//
SPIFI_ADDR = AddrReg;
SPIFI_IDATA = IDataReg;
SPIFI_CMD = CmdReg;
//
// Wait for the command to start execution.
//
if (NumBytesData) {
    while (1) {
        if (SPIFI_STAT & (1uL << STAT_CMD_BIT)) {
            break;
        }
    }
}
//
// Write data to NOR flash.
//
if (NumBytesData) {
    do {
        NumBytesAtOnce = NumBytesData >= 4 ? 4 : 1;
        if (NumBytesAtOnce == 4) {
            v = 0
                | (U32)*pData
                | ((U32)*(pData + 1)) << 8
                | ((U32)*(pData + 2)) << 16
                | ((U32)*(pData + 3)) << 24
                ;
            SPIFI_DATA32 = v;
        } else {
            SPIFI_DATA8 = *pData;
        }
    }
}

```

```

        NumBytesData -= NumBytesAtOnce;
        pData         += NumBytesAtOnce;
    } while (NumBytesData);
}
//
// Wait until nCS is set high, indicating that the command has been completed.
//
while (1) {
    if ((SPIFI_STAT & (1uL << STAT_CMD_BIT)) == 0) {
        break;
    }
}
}

/*****
 *
 *      _HW_Poll
 *
 * Function description
 * HW layer function. Sends a command repeatedly and checks the
 * response for a specified condition.
 *
 * Return value
 * > 0   Timeout occurred.
 * ==0   OK, bit set to specified value.
 * < 0   Feature not supported.
 *
 * Additional information
 * The function executes periodically a command and waits
 * until specified bit in the response returned by the NOR flash
 * is set to a value specified by BitValue. The position of the bit
 * that has to be checked is specified by BitPos where 0 is the
 * position of the least significant bit in the byte.
 */
static int _HW_Poll(U8 Unit, U8 Cmd, U8 BitPos, U8 BitValue, U32 Delay, U32 TimeOut_ms, U16 BusWidth) {
    int r;

    ASSERT_IS_LOCKED();
    FS_USE_PARA(Unit);
    FS_USE_PARA(Delay);
    r = -1; // Set to indicate that the feature is not supported.
#ifdef USE_OS
    {
        U32 AddrReg;
        U32 IDataReg;
        U32 CmdReg;
        U32 FieldForm;
        int IsDual;
        U32 FrameForm;
        U32 v;

        //
        // Fill local variables.
        //
        IsDual = 0;
        FieldForm = _GetFieldForm(BusWidth, &IsDual);
        FrameForm = _GetFrameForm(0);
        // The command does not require any address bytes.
        AddrReg = 0;
        IDataReg = 0;
        CmdReg = 0
            | ((BitValue & CMD_BITVAL_MASK) << CMD_BITVAL_BIT)
            | ((BitPos & CMD_BITPOS_MASK) << CMD_BITPOS_BIT)
            | (1uL << CMD_POLL_BIT)
            | (FieldForm << CMD_FIELDFORM_BIT)
            | (FrameForm << CMD_FRAMEFORM_BIT)
            | (Cmd << CMD_OPCODE_BIT)
            ;

        //
        // Set dual/quad mode.
        //
        v = SPIFI_CTRL;
        if (IsDual) {
            v |= 1uL << CTRL_DUAL_BIT;
        } else {
            v &= ~(1uL << CTRL_DUAL_BIT);
        }
    }
#endif
}

```

```

    }
    SPIFI_CTRL = v;
    //
    // Execute the command.
    //
    SPIFI_STAT = 1uL << STAT_INTROQ_BIT; // Clear the interrupt flag.
    SPIFI_CTRL |= 1uL << CTRL_INTEN_BIT; // Enable interrupt.
    SPIFI_ADDR = AddrReg;
    SPIFI_IDATA = IDataReg;
    SPIFI_CMD = CmdReg;
    r = FS_X_OS_Wait(TimeOut_ms);
    SPIFI_CTRL &= ~(1uL << CTRL_INTEN_BIT); // Disable interrupt.
    if (r) {
        r = 1; // A timeout occurred.
    } else {
        r = 0; // Bit set to the requested value.
    }
    _Reset(); // Cancel the polling operation.
    //
    // Wait until nCS is set high, indicating that the command has been completed.
    //
    while (1) {
        if ((SPIFI_STAT & (1uL << STAT_CMD_BIT)) == 0) {
            break;
        }
    }
}
#else
    FS_USE_PARA(Cmd);
    FS_USE_PARA(BitPos);
    FS_USE_PARA(BitValue);
    FS_USE_PARA(Delay);
    FS_USE_PARA(TimeOut_ms);
    FS_USE_PARA(BusWidth);
#endif
return r;
}

/*****
 *
 *      _HW_Delay
 *
 * Function description
 * HW layer function. Blocks the execution for the specified number
 * of milliseconds.
 */
static int _HW_Delay(U8 Unit, U32 ms) {
    int r;

    FS_USE_PARA(Unit);
    r = -1; // Set to indicate that the feature is not supported.
    #if USE_OS
        if (ms) {
            FS_X_OS_Delay(ms);
            r = 0;
        }
    #else
        FS_USE_PARA(ms);
    #endif
    return r;
}

/*****
 *
 *      _HW_Lock
 *
 * Function description
 * HW layer function. Requests exclusive access to SPI bus.
 */
static void _HW_Lock(U8 Unit) {
    FS_USE_PARA(Unit);
    IF_TEST(_LockCnt++);
    ASSERT_IS_LOCKED();
}

/*****

```



```

*
*   _HW_Unlock
*
*   Function description
*   HW layer function. Releases the exclusive access of SPI bus.
*/
static void _HW_Unlock(U8 Unit) {
    FS_USE_PARA(Unit);
    ASSERT_IS_LOCKED();
    IF_TEST(_LockCnt--);
}

/*****
*
*   Global data
*
*****/
const FS_NOR_HW_TYPE_SPIFI FS_NOR_HW_SPIFI_LPC4322_SEGGER_QSPIFI_Test_Board = {
    _HW_Init,
    _HW_SetCmdMode,
    _HW_SetMemMode,
    _HW_ExecCmd,
    _HW_ReadData,
    _HW_WriteData,
    _HW_Poll,
    _HW_Delay,
    _HW_Lock,
    _HW_Unlock,
    NULL,
    NULL,
    NULL,
    NULL,
    NULL
};

/***** End of file *****/

```

6.5 MMC/SD card driver

6.5.1 General information

emFile supports the use of MultiMediaCard (MMC) and Secure Digital (SD) cards as well as of eMMC (Embedded MMC) as storage device.

MMC/SD cards are mechanically small, removable mass storage devices. The main design goal of these devices is to provide a very low cost mass storage product, implemented as a card with a simple controlling unit, and a compact, easy-to-implement interface. These requirements lead to a reduction of the functionality of each card to an absolute minimum. eMMC devices operate in the same way as an MMC card with the difference that they are not removable devices. Instead, they can be soldered on a circuit board.

In order to meet the requirements of any system, the MMC/SD cards are designed to operate in two different I/O modes:

- SPI mode
- Card mode

Two device drivers are provided that support these different operating modes:

- *SPI MMC/SD driver* - Supports legacy MMC and SD cards and it transfers the data via standard SPI.
- *Card Mode MMC/SD driver* - Supports legacy eMMC and SD cards and it can transfer the data via one, four or eight data lines. The drivers require very little RAM and provide and extremely efficient data transfer. The selection of the driver depends on the access mode supported by the target hardware.

For more technical details about MMC and SD cards, check the documents and specifications available on <https://www.jedec.org> and <https://www.sdcard.org>

6.5.1.1 Fail-safe operation

The data will be preserved in case of unexpected reset. However, a power failure can be critical because data may be lost if the SD card does not have sufficient time to complete the in-progress write operation. As a countermeasure, the hardware has to make sure that the power supply to the SD card drops slowly enough to allow the SD card to complete the write operation. The SD specification requires that a write operation has to finish within 250 ms time. However, an SD card is allowed to buffer the data written by host and that can potentially increase the time it takes the SD card to complete the write operation. This type of write buffering can be disabled via `FS_MMC_CM_AllowBufferedWrite()`. Typically, industrial-grade SD cards are able to handle power failures internally so that no special hardware and software considerations are required.

eMMC devices have the same requirements in regards to the fail-safe operation as SD cards. In addition, eMMC devices have the ability to write the data in a fail-safe way that reduces the chance of a data loss in case of a power failure. This type of write operation is called Reliable Write and can be enabled via `FS_MMC_CM_AllowReliableWrite()`. Enabling this write mode is recommended for a correct fail-safe operation of the file system.

6.5.1.2 Wear leveling

MMC/SD cards are controlled by an internal controller, this controller also handles wear leveling. Therefore, the driver does not need to handle wear-leveling.

6.5.1.3 CRC verification

CRC (Cyclic Redundancy Check) is a method to produce a checksum. The checksum is a small, fixed number of bits calculated based on the contents of a block of data. The checksum is used to detect errors in a data block after transmission or storage. A CRC is computed and appended before transmission or storage, and verified afterwards by the recipient to confirm that no changes occurred. CRC is a good solution for error detection, but reduces the transmission speed, because a CRC checksum has to be computed for every

data block is transmitted or stored. `FS_MMC_ActivateCRC()` and `FS_MMC_DeactivateCRC()` can be used to control the CRC calculation of the SPI MMC/SD driver. The Card Mode MMC/SD driver calculates the CRC in the hardware with the help of the SD host controller. In this case, the CRC calculation and verification is always enabled and it can not be deactivated.

6.5.1.4 Power control

Power control should be considered when creating designs using the MMC and/or SD cards. The ability to have software power control of the cards makes the design more flexible and robust. The host will be able to turn power to the card on or off independent of whether the card is inserted or removed. This can improve card initialization when there is a contact bounce during card insertion. The host waits a specified time after the card is inserted before powering up the card and starting the initialization process. Also, if the card goes into an unknown state, the host can cycle the power and start the initialization process again. When card access is unnecessary, allowing the host to power-down the bus can reduce the overall power consumption.

6.5.1.5 Supported hardware

Generally emFile supports any SD card that comply with any the version of the SD Specification up to and including 3.0. In addition, MMC devices are supported that comply with the any version of the MMC Specification up to and including 5.0.

The following memory card and device types are supported:

- MMC - eMMC, MMC card, RS-MMC, RS-MMC DV, MMCplus, MMCmobile, MMCmicro
- SD - SDSC (SD Standard Capacity), SDHC (SD High Capacity), SDXC (SD eXtended Capacity) in any form factor.

Note

The MMC cards conforming with the version 4.x or newer of the MMC specification (MMCplus, MMCmobile, MMCmicro, eMMC, etc.) work only with the Card Mode MMC/SD driver because these devices do not support the SPI mode.

The difference between MMC and SD cards is that SD cards can operate with a higher clock frequency. In normal mode the range range of the clock frequency supplied to an SD card can be between 0 and 25 MHz, whereas MMC cards can only operate up to 20 MHz. The newer MMC cards that comply to the version 4.x or higher of the MMC specification can also operate at higher frequencies up to 26 MHz.

An SD card can also operate in high speed mode with a clock frequency up to 50 MHz. The MMC cards conforming to the version 3.x or lower of the MMC specification do not support the high speed mode. The version 4.x of the MMC specification improves this and allows the MMC cards to operate with a clock frequency of up to 52 MHz in high speed mode.

The version 3.0 of the SD Specification and the version 4.5 of the MMC Specification introduce new access modes that allow the devices to exchanged the data with a host at a clock frequency of up to around 200 MHz in single and dual data rate modes. These ultra high speed access modes use a voltage level of 1.8 V for SD cards and either 1.8 or 1.2 V for MMC devices for the I/O signals. The following table lists the access modes currently supported by emFile:

Device Type	Access Mode	Data Rate	I/O Voltage [V]	Bus Width [Data Lines]	Max. Clock Frequency [MHz]
SD	Default Speed	Single	3.3	1, 4	25
SD	High Speed	Single	3.3	1, 4	50
SD	SDR12	Single	1.8	1, 4	25
SD	SDR25	Single	1.8	1, 4	50
SD	DDR50	Dual	1.8	4	50

Device Type	Access Mode	Data Rate	I/O Voltage [V]	Bus Width [Data Lines]	Max. Clock Frequency [MHz]
SD	SDR50	Single	1.8	4	100
SD	SDR104	Single	1.8	4	208
MMC	Default Speed	Single	3.3, 1.8	1, 4, 8	26
MMC	High Speed	Single	3.3, 1.8	1, 4, 8	52
MMC	High Speed	Dual	3.3, 1.8	4, 8	52
MMC	HS200	Single	1.8	4, 8	200
MMC	HS400	Dual	1.8	8	200

The HS400 Enhanced Strobe mode and 1.2 V I/O voltage are currently not supported for eMMC. The ultra high speed access modes are supported only by the Card Mode MMC/SD driver.

MMC and SD cards also differ in the number of interface signals with MMC cards typically requiring more signals than the SD cards. The number of signals used depends on the operating mode.

Card mode

In this mode the MMC cards compliant to version 3.x or smaller of the MMC specification require 6 signals: 1 command, 1 clock, 1 data and 3 power lines. The MMC cards compliant with the version 4.x or higher of the MMC specification require up to 13 signals: 1 command, 1 clock, up to 8 data and 3 power lines. In contrast to the MMC cards, SD cards require up to 9 signals: 1 command, 1 clock, up to 4 data and 3 power lines.

SPI mode

Both card systems use the same interface signals: 1 chip select, 1 data input, 1 data output, 1 clock and 3 power lines.

6.5.1.6 Pin description - MMC/SD card in card mode

The table below describes the pin assignment of the electrical interface of SD and MMC cards working in card mode

Pin No.	Name	Type	Description
1	CD/DAT3	Input/Output using push pull drivers	Card Detect / Data line [Bit 3]. After power up this line is input with 50-kOhm pull-up resistor. This can be used for card detection; relevant only for SD cards. The pull-up resistor is disabled after the initialization procedure for using this line as DAT3, Data line [Bit 3], for data transfer.
2	CMD	Push Pull	Command/Response. CMD is a bidirectional command channel used for card initialization and data transfer commands. The CMD signal has two operation modes: open-drain for initialization mode and push-pull for fast command transfer. Commands are sent from the MMC bus master (card host controller) to the card and responses are sent from the cards to the host.
3	VSS	Power supply	Supply voltage ground.
4	VDD	Power supply	Supply voltage.
5	CLK	Input	Clock signal. With each cycle of this signal a one bit transfer on the command and data lines

Pin No.	Name	Type	Description
			is done. The frequency may vary between zero and the maximum clock frequency.
6	VSS2	Power supply	Supply voltage ground.
7	DAT0	Input/Output using push pull drivers	Data line [Bit 0]. DAT is a bidirectional data channel. The DAT signal operates in push-pull mode. Only one card or the host is driving this signal at a time. Relevant only for SD cards: For data transfers, this line is the Data line [Bit 0].
8	DAT1	Input/Output using push pull drivers	Data line [Bit 1]. For data transfer, this line is the Data line [Bit 1]. Connect an external pull-up resistor to this data line even if only DAT0 is to be used. Otherwise, non-expected high current consumption may occur due to the floating inputs of DAT1.
9	DAT2	Input/Output using push pull drivers	Data line [Bit 2]. For data transfer, this line is the Data line [Bit 2]. Connect an external pull-up resistor to this data line even if only DAT0 is to be used. Otherwise, non-expected high current consumption may occur due to the floating inputs of DAT2.
10	DAT4	Input/Output using push pull drivers	Data line [Bit 4]. Relevant only for MMC storage devices. On SD cards this line does not exist. Not used for data transfers via four data lines. For data transfer via eight data lines, this line is carries the bit 4.
11	DAT5	Input/Output using push pull drivers	Data line [Bit 5]. Relevant only for MMC storage devices. On SD cards this line does not exist. Not used for data transfers via four data lines. For data transfer via eight data lines, this line is carries the bit 5.
12	DAT6	Input/Output using push pull drivers	Data line [Bit 6]. Relevant only for MMC storage devices. On SD cards this line does not exist. Not used for data transfers via four data lines. For data transfer via eight data lines, this line is carries the bit 6.
13	DAT7	Input/Output using push pull drivers	Data line [Bit 7]. Relevant only for MMC storage devices. On SD cards this line does not exist. Not used for data transfers via four data lines. For data transfer via eight data lines, this line is carries the bit 7.

The table below describes the pin assignment of the electrical interface of a micro SD card working in card mode

Pin no.	Name	Type	Description
1	DAT2	Input/Output using push pull drivers	Data line [Bit 2]. On MMC card this line does not exist. Relevant only for SD cards: For data transfer, this line is the Data line [Bit 2]. Connect an external pull-up resistor to this data line even if only DAT0 is to be used. Otherwise, non-expected high current consumption may occur due to the floating inputs of DAT2.
2	CD/DAT3	Input/Output using push pull drivers	Card Detect / Data line [Bit 3]. After power up this line is input with 50-kOhm pull-up resistor. This can be used for card detection; relevant

Pin no.	Name	Type	Description
			only for SD cards. The pull-up resistor is disabled after the initialization procedure for using this line as DAT3, Data line [Bit 3], for data transfer.
3	CMD	Push Pull	Command/Response. CMD is a bidirectional command channel used for card initialization and data transfer commands. The CMD signal has two operation modes: open-drain for initialization mode and push-pull for fast command transfer. Commands are sent from the MMC bus master (card host controller) to the card and responses are sent from the cards to the host.
4	VDD	Power supply	Supply voltage.
5	CLK	Input	Clock signal. With each cycle of this signal an one bit transfer on the command and data lines is done. The frequency may vary between zero and the maximum clock frequency.
6	VSS	Power supply	Supply ground.
7	DAT0	Input/Output using push pull drivers	Data line [Bit 0]. DAT is a bidirectional data channel. The DAT signal operates in push-pull mode. Only one card or the host is driving this signal at a time. Relevant only for SD cards: For data transfers, this line is the Data line [Bit 0].
8	DAT1	Input/Output using push pull drivers	Data line [Bit 1]. On MMC card this line does not exist. Relevant only for SD cards: For data transfer, this line is the Data line [Bit 1]. Connect an external pull-up resistor to this data line even if only DAT0 is to be used. Otherwise, non-expected high current consumption may occur due to the floating inputs of DAT1.

Additional information

External pull-up resistors must be connected to all data lines even it they are not used. Otherwise, unexpected high current consumption may occur due to the floating of these signals.

6.5.1.7 Pin description - MMC/SD card in SPI mode

The table below describes the pin assignment of the electrical interface of SD and MMC cards working in SPI mode

Pin no.	Name	Type	Description
1	CS	Input	Chip Select. It sets the card active at low-level and inactive at high level.
2	DataIn (MOSI)	Input	Data Input (Master Out Slave In.) Transmits data to the card.
3	VSS	Supply ground	Power supply ground. Supply voltage ground.
4	VDD	Supply voltage	Supply voltage.
5	SCLK	Input	Clock signal. It must be generated by the target system. The card is always in slave mode.
6	VSS2	Supply ground	Supply ground.

Pin no.	Name	Type	Description
7	DataOut (MISO)	Output	Data Output (Master In Slave Out.) Line to transfer data to the host.
8	Reserved	Not used	The reserved pin is a floating input. Therefore, connect an external pull-up resistor to it. Otherwise, non-expected high current consumption may occur due to the floating input.
9	Reserved	Not used	The reserved pin is a floating input. Therefore, connect an external pull-up resistor to it. Otherwise, non-expected high current consumption may occur due to the floating input.

The table below describes the pin assignment of the electrical interface of a micro SD card working in SPI mode:

Pin no.	Name	Type	Description
1	Reserved	Not used	The reserved pin is a floating input. Therefore, connect an external pull-up resistor to it. Otherwise, non-expected high current consumption may occur due to the floating input.
2	CS	Input	Chip Select. It sets the card active at low-level and inactive at high level.
3	DataIn (MOSI)	Input	Data Input (Master Out Slave In.) Transmits data to the card.
4	VDD	Supply voltage	Supply voltage.
5	SCLK	Input	Clock signal. It must be generated by the target system. The card is always in slave mode.
6	VSS	Supply ground	Supply ground.
7	DataOut (MISO)	Output	Data Output (Master In Slave Out.) Line to transfer data to the host.
8	Reserved	Not used	The reserved pin is a floating input. Therefore, connect an external pull-up resistor to it. Otherwise, non-expected high current consumption may occur due to the floating input.

Additional information

- The data transfer width is 8 bits.
- Data should be output on the falling edge and must remain valid until the next period. Rising edge means data is sampled (i.e. read).
- The bit order requires most significant bit (MSB) to be sent out first.
- Data polarity is normal, which means a logical "1" is represented with a high level on the data line and a logical "0" is represented with low-level.
- MMC/SD cards support different voltage ranges. Initial voltage should be 3.3V.

6.5.1.8 Interfacing with an MMC/SD card

The following picture shows how an MMC/SD card working in card mode can be interfaced to a system.

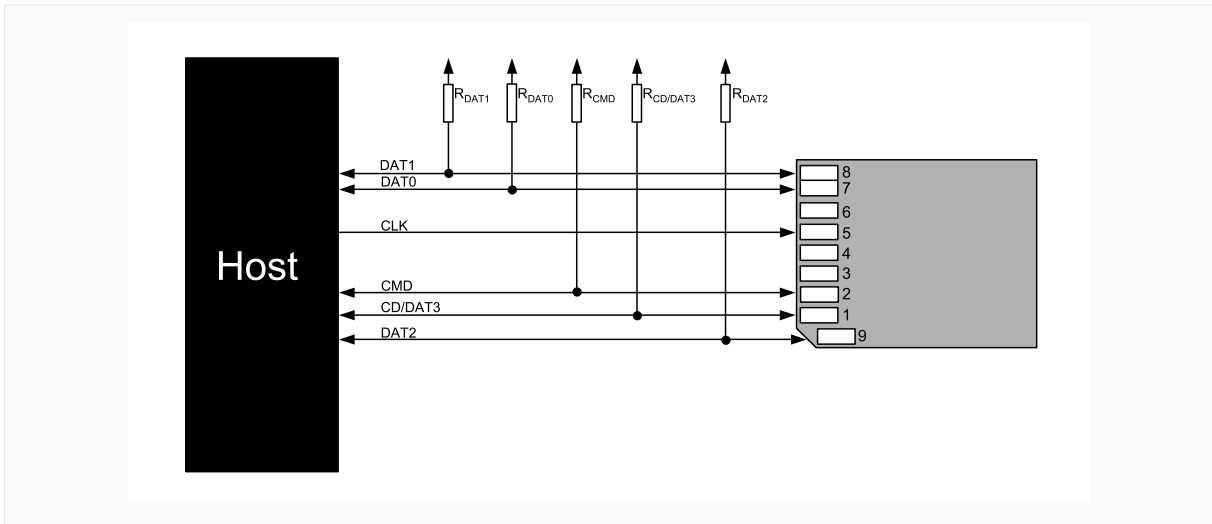

SD card schematic - card mode

The following picture shows how an MMC/SD card working in SPI mode can be interfaced to a system.

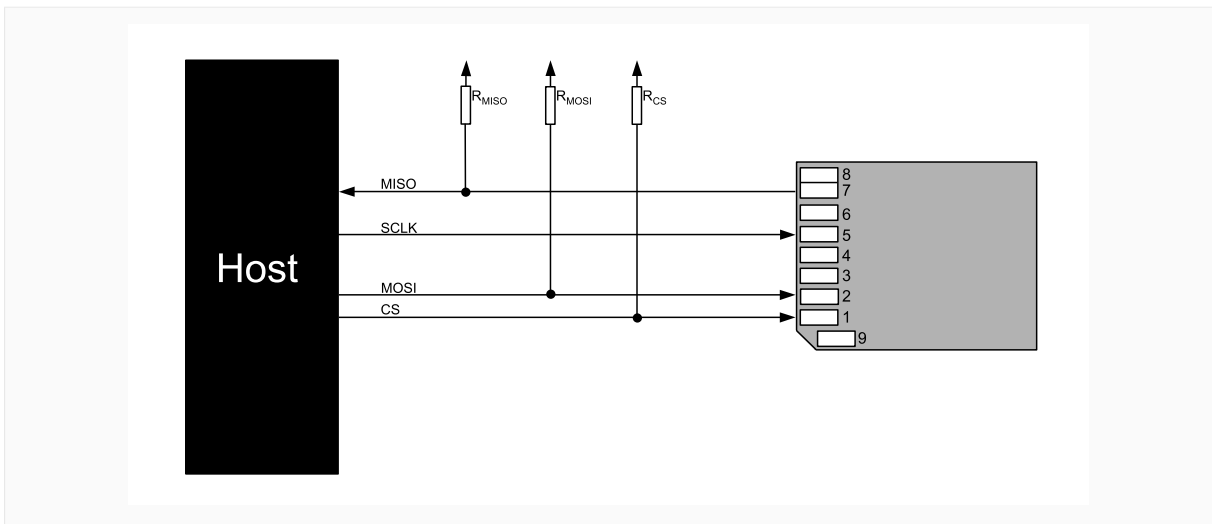

SD card schematic - SPI mode

6.5.2 SPI MMC/SD driver

6.5.2.1 Theory of operation

The Serial Peripheral Interface (SPI) bus is a very loose de facto standard for controlling almost any digital electronics that accepts a clocked serial stream of bits. SPI operates in full duplex (sending and receiving at the same time).

6.5.2.2 Configuring the driver

This section describes how to configure the file system to make use of the SPI MMC/SD driver.

6.5.2.2.1 Runtime configuration

The driver must be added to the file system by calling `FS_AddDevice()` with the driver identifier set to the address of `FS_MMC_SPI_Driver` structure. This function call together with other function calls that configure the driver operation have to be added to `FS_X_AddDevices()` as demonstrated in the following example. This example shows how to configure the file system to access an MMC/SD card connected via SPI.

```
#include "FS.h"
#include "FS_MMC_HW_SPI_Template.h"

#define ALLOC_SIZE 0x1300           // Size defined in bytes

static U32 _aMemBlock[ALLOC_SIZE / 4]; // Memory pool used for
                                        // semi-dynamic allocation.

/*****
 *
 *      FS_X_AddDevices
 *
 *      Function description
 *      This function is called by the FS during FS_Init().
 */
void FS_X_AddDevices(void) {
    //
    // Give the file system memory to work with.
    //
    FS_AssignMemory(&_aMemBlock[0], sizeof(_aMemBlock));
    //
    // Add and configure the SPI MMC/SD driver.
    //
    FS_AddDevice(&FS_MMC_SPI_Driver);
    FS_MMC_SetHWType(0, &FS_MMC_HW_SPI_Template);
    // FS_MMC_ActivateCRC(); // Uncommenting this line activates
                            // the CRC calculation of the SPI MMC/SD driver.
    //
    // Configure the file system for fast write operations.
    //
#ifdef FS_SUPPORT_FILE_BUFFER
    FS_ConfigFileBufferDefault(512, FS_FILE_BUFFER_WRITE);
#endif
    FS_SetFileWriteMode(FS_WRITEMODE_FAST);
}
```

The API functions listed in the next table can be used by the application to configure the behavior of the SPI MMC/SD driver. The application can call them only at the file system initialization in `FS_X_AddDevices()`.

Function	Description
<code>FS_MMC_ActivateCRC()</code>	Enables the data verification.
<code>FS_MMC_DeactivateCRC()</code>	Disables the data verification.
<code>FS_MMC_SetHWType()</code>	Configures the hardware access routines.

6.5.2.2.1.1 FS_MMC_ActivateCRC()

Description

Enables the data verification.

Prototype

```
void FS_MMC_ActivateCRC(void);
```

Additional information

This function is optional. The data verification uses a 16-bit CRC to detect any corruption of the data being exchanged with the storage device. By default, the data verification is disabled to improve performance. `FS_MMC_ActivateCRC()` can be used at runtime to enable the data verification for all driver instances. The data verification can be disabled via `FS_MMC_DeactivateCRC()`.

6.5.2.2.1.2 FS_MMC_DeactivateCRC()

Description

Disables the data verification.

Prototype

```
void FS_MMC_DeactivateCRC(void);
```

Additional information

This function is optional. It can be used by an application to disable the data verification previously enabled via `FS_MMC_ActivateCRC()`.

6.5.2.2.1.3 FS_MMC_SetHWType()

Description

Configures the hardware access routines.

Prototype

```
void FS_MMC_SetHWType(      U8          Unit,
                          const FS_MMC_HW_TYPE_SPI * pHWType);
```

Additional information

This function is mandatory and it has to be called once for each instance of the driver.

6.5.2.3 Additional driver functions

These functions are optional. They can be used to get information about the operation of the Card Mode MMC/SD driver and to perform additional operations on the used SD card or MMC device.

Function	Description
<code>FS_MMC_GetCardId()</code>	This function retrieves the card Id of SD/MMC card.
<code>FS_MMC_GetCardInfo()</code>	This function returns information about the SD/MMC device.
<code>FS_MMC_GetStatCounters()</code>	Returns the value of statistical counters.
<code>FS_MMC_ResetStatCounters()</code>	Sets the values of all statistical counters to 0.

6.5.2.3.1 FS_MMC_GetCardId()

Description

This function retrieves the card Id of SD/MMC card.

Prototype

```
int FS_MMC_GetCardId(U8 Unit,
                    FS_MMC_CARD_ID * pCardId);
```

Parameters

Parameter	Description
Unit	Device index number.
pCardId	out Card identification data.

Return value

= 0 CardId has been read.
 ≠ 0 An error has occurred.

Additional information

This function is optional. The application can call this function to get the information stored in the CID register of an MMC or SD card. The CID register stores information which can be used to uniquely identify the card such as serial number, product name, manufacturer id, etc. For more information about the information stored in this register refer to SD or MMC specification.

Example

The following example shows how to read and decode the contents of the CID register.

```
#include <stdio.h>
#include "FS.h"

void SampleMMCGetCardId(void) {
    U8      ManId;
    char    acOEMId[2 + 1];
    char    acProductName[5 + 1];
    U8      ProductRevMajor;
    U8      ProductRevMinor;
    U32     ProductSN;
    U8      MfgMonth;
    U16     MfgYear;
    U16     MfgDate;
    U8      * p;
    MMC_CARD_ID CardId;
    char    ac[100];

    FS_MEMSET(&CardId, 0, sizeof(CardId));
    FS_MMC_GetCardId(0, &CardId);
    p = CardId.aData;
    ManId = *p++;
    strncpy(acOEMId, (char *)p, 2);
    acOEMId[2] = '\0';
    p += 2;
    strncpy(acProductName, (char *)p, 5);
    acProductName[5] = '\0';
    p += 5;
    ProductRevMajor = *p >> 4;
    ProductRevMinor = *p++ & 0xF;
    ProductSN = (U32)*p++ << 24;
    ProductSN |= (U32)*p++ << 16;
    ProductSN |= (U32)*p++ << 8;
    ProductSN |= (U32)*p++;
    MfgDate = (U16)*p++;
    MfgDate |= (U16)*p++;
```

```
MfgMonth      = (U8)(MfgDate & 0xF);
MfgYear       = MfgDate >> 4;
FS_X_Log("SD card identification:\n");
SEGGER_snprintf(ac, sizeof(ac), "  Manufacturer Id:      0x%02x\n", ManId);
FS_X_Log(ac);
SEGGER_snprintf(ac, sizeof(ac), "  OEM/Application Id:   %s\n", acOEMId);
FS_X_Log(ac);
SEGGER_snprintf(ac, sizeof(ac), "  Product name:        %s\n", acProductName);
FS_X_Log(ac);
SEGGER_snprintf(ac, sizeof(ac), "  Product revision:    %lu.%lu\n", (U32)ProductRevMajor, (U32)ProductRevMinor);
FS_X_Log(ac);
SEGGER_snprintf(ac, sizeof(ac), "  Product serial number: 0x%08lx\n", ProductSN);
FS_X_Log(ac);
SEGGER_snprintf(ac, sizeof(ac), "  Manufacturing date:   %lu-%lu\n", (U32)MfgMonth, (U32)MfgYear);
FS_X_Log(ac);
}
```

6.5.2.3.2 FS_MMC_GetCardInfo()

Description

This function returns information about the SD/MMC device.

Prototype

```
int FS_MMC_GetCardInfo(U8 Unit,
                      FS_MMC_CARD_INFO * pCardInfo);
```

Parameters

Parameter	Description
Unit	Index of the driver instance (0-based).
pCardInfo	out Information about the device.

Return value

= 0 Card information returned.
 ≠ 0 An error has occurred.

Additional information

This function is optional. It can be used to get information about the type of the storage card used, about the type of the data transfer, etc.

Example

The following example shows how to get information about the storage device.

```
#include <stdio.h>
#include "FS.h"

void SampleMMCGetCardInfo(void) {
    FS_MMC_CARD_INFO CardInfo;
    const char * sCardType;
    char ac[100];
    const char * sAccessMode;

    FS_MEMSET(&CardInfo, 0, sizeof(CardInfo));
    FS_MMC_GetCardInfo(0, &CardInfo);
    switch (CardInfo.CardType) {
    case FS_MMC_CARD_TYPE_MMC:
        sCardType = "MMC";
        break;
    case FS_MMC_CARD_TYPE_SD:
        sCardType = "SD";
        break;
    case FS_MMC_CARD_TYPE_UNKNOWN:
        // through
    default:
        sCardType = "UNKNOWN";
        break;
    }
    switch (CardInfo.AccessMode) {
    case FS_MMC_ACCESS_MODE_DS:
        sCardType = "DS";
        break;
    case FS_MMC_ACCESS_MODE_HS:
        sCardType = "HS";
        break;
    case FS_MMC_ACCESS_MODE_UNKNOWN:
        // through
    default:
        sCardType = "UNKNOWN";
        break;
    }
    FS_X_Log("Card information:");
    SEGGER_sprintf(ac, sizeof(ac), " Card type: %s\n", sCardType);
```

```
FS_X_Log(ac);
SEGGER_sprintf(ac, sizeof(ac), " Bus width:          %d line\n", CardInfo.BusWidth);
FS_X_Log(ac);
SEGGER_sprintf(ac, sizeof(ac), " Write protected:    %s\n",
  CardInfo.IsWriteProtected ? "yes" : "no");
FS_X_Log(ac);
SEGGER_sprintf(ac, sizeof(ac), " High speed mode:    %s\n",
  CardInfo.IsHighSpeedMode ? "yes" : "no");
FS_X_Log(ac);
SEGGER_sprintf(ac, sizeof(ac), " Bytes per sector:  %d\n",
  (int)CardInfo.BytesPerSector);
FS_X_Log(ac);
SEGGER_sprintf(ac, sizeof(ac), " Number of sectors: %lu\n", CardInfo.NumSectors);
FS_X_Log(ac);
SEGGER_sprintf(ac, sizeof(ac), " Clock frequency:   %lu Hz\n", CardInfo.ClockFreq);
FS_X_Log(ac);
SEGGER_sprintf(ac, sizeof(ac), " Voltage level:     %d.%d V\n",
  (int)CardInfo.VoltageLevel / 1000, (int)CardInfo.VoltageLevel % 1000 / 100);
FS_X_Log(ac);
SEGGER_sprintf(ac, sizeof(ac), " Access mode:       %s\n", sAccessMode);
FS_X_Log(ac);
}
```

6.5.2.3.3 FS_MMC_GetStatCounters()

Description

Returns the value of statistical counters.

Prototype

```
void FS_MMC_GetStatCounters(U8 Unit,
                             FS_MMC_STAT_COUNTERS * pStat);
```

Parameters

Parameter	Description
<code>Unit</code>	Index of the driver (0-based)
<code>pStat</code>	out The values of statistical counters.

Additional information

This function is optional. The SPI SD/MMC driver collects statistics about the number of internal operations such as the number of logical sectors read or written by the file system layer. The application can use `FS_MMC_GetStatCounters()` to get the current value of these counters. The statistical counters are automatically set to 0 when the storage device is mounted or when the application calls `FS_MMC_ResetStatCounters()`.

The statistical counters are available only when the file system is compiled with `FS_DEBUG_LEVEL` greater than or equal to `FS_DEBUG_LEVEL_CHECK_ALL` or with `FS_MMC_ENABLE_STATS` set to 1.

6.5.2.3.4 FS_MMC_ResetStatCounters()

Description

Sets the values of all statistical counters to 0.

Prototype

```
void FS_MMC_ResetStatCounters(U8 Unit);
```

Parameters

Parameter	Description
<code>Unit</code>	Index of the driver instance (0-based).

Additional information

This function is optional. The statistical counters are automatically set to 0 when the storage device is mounted. The application can use `FS_MMC_ResetStatCounters()` at any time during the file system operation. The statistical counters can be queried via `FS_MMC_GetStatCounters()`.

The statistical counters are available only when the file system is compiled with `FS_DEBUG_LEVEL` greater than or equal to `FS_DEBUG_LEVEL_CHECK_ALL` or with `FS_MMC_ENABLE_STATS` set to 1.

6.5.2.4 Performance and resource usage

6.5.2.4.1 ROM usage

The ROM usage depends on the compiler options, the compiler version and the used CPU. The memory requirements of the Card Mode MMC/SD driver were measured as described in the section *Test procedure* on page 1283.

Usage: 2.8 Kbytes

6.5.2.4.2 Static RAM usage

Static RAM usage refers to the amount of RAM required by the Card Mode MMC/SD driver internally for all the driver instances. The number of bytes can be seen in the compiler list file of the `FS_MMC_CM_Drv.c` file.

Usage: 12 bytes

6.5.2.4.3 Dynamic RAM usage

Dynamic RAM usage is the amount of RAM allocated by the driver at runtime. The amount of RAM required depends on the compile time and runtime configuration.

Usage: 22 bytes

6.5.2.4.4 Performance

These performance measurements are in no way complete, but they give an approximation of the length of time required for common operations on various targets. The tests were performed as described in the section *Performance* on page 1289. All values are given in Mbytes/second.

CPU type	MMC/SD device	Write speed	Read speed
Atmel AT91SAM7S (48 MHz)	Ultron 256MB SD card	2.3	2.3
Atmel AT91SAM9261 (178 MHz)	Ultron 256MB SD card	2.3	2.5
TI TM4C129	SanDisk 16GB Ultra PLUS SD card	2.0	2.2
NXP LPC1768	SanDisk Extreme PRO 32GB	1.6	1.6
ST STM32H753	SanDisk Extreme PRO 32GB	1.4	1.5

6.5.3 Card Mode MMC/SD driver

6.5.3.1 Configuring the driver

This section describes how to configure the file system to make use of the Card Mode MMC/SD driver.

6.5.3.1.1 Compile time configuration

The Card Mode MMC/SD driver can optionally be configured at compile time. Typically, this step can be omitted because the Card Mode MMC/SD driver provides reasonable default values that work for most of the target applications. The compile time configuration is realized via preprocessor defines that have to be added to the `FS_Conf.h` file which is the main configuration file of emFile. For detailed information about the configuration of emFile and of the configuration define types, refer to *Configuration of emFile* on page 1218. The following table lists the configuration defines supported by the Card Mode MMC/SD driver.

Define	Default value	Type	Description
FS_MM- C_DISABLE_DAT3_PULLUP	0	B	Configures if the internal pull-up mounted on the DAT3 signal has to be disabled.
FS_MMC_ENABLE_STATS	0 or 1	B	Enables or disables the support for statistical counters.
FS_MMC_NUM_RETRIES	5	N	Configures the number of retries in case of a read or write error.
FS_MMC_NUM_UNITS	2	N	Maximum number of driver instances.
FS_MMC_READ_DATA_TIMEOUT	0	N	Maximum number milliseconds to wait for the data to be received from the storage device.
FS_MMC_READ_SINGLE_LAST_SECTOR	0	B	Configures how the last sector of the storage device has to be read.
FS_MMC_SELECT_CARD_TIMEOUT	512	N	Maximum number of times a failed card select operation has to be repeated.
FS_MMC_SUPPORT_MMC	1	B	Enables or disables the handling of MMC devices.
FS_MMC_SUPPORT_POWER_SAVE	0	B	Enables or disables the support for putting an MMC device to sleep mode.
FS_MMC_SUPPORT_SD	1	B	Enables or disables the handling of SD cards.
FS_MMC_SUPPORT_TRIM	0	B	Enables or disables the support for marking a logical sector as not in use.
FS_MMC_SUPPORT_UHS	0	B	Enables or disables the data access with clock frequencies up to 200 MHz.
FS_MMC_TEST_BUS_WIDTH	0	B	Enables or disables the detection of the number of connected data signals.
FS_MMC_WAIT_READY_TIMEOUT	0x00FFFFFF	N	Maximum number of times to check for the ready status of the storage device.

6.5.3.1.1.1 FS_MMC_DISABLE_DAT3_PULLUP

An SD card has an internal pull-up mounted on the DAT3 signal that can be used for card detection. Typically, this way detecting the presence of an SD card is not used. Instead, the SD card slot has a mechanical switch that is used for this purpose. The internal pull-up is no longer necessary after the initialization of the SD card. Therefore, the SD Specification recommends to disable the pull-up during data transfers that use the DAT3 signal that is when the data is transferred via four data lines. If `FS_MMC_DISABLE_DAT3_PULLUP` is set to 1 then the Card Mode MMC/SD driver will disable the pull up before the SD card is configured to transfer the data via the four data lines.

6.5.3.1.1.2 FS_MMC_ENABLE_STATS

This define can be used to enable the support for statistical counters. The statistical counters provide information about the number of operations performed internally by the Card Mode MMC/SD driver that can be useful for debugging. The statistical counters can be queried via `FS_MMC_CM_GetStatCounters()` and set to 0 via `FS_MMC_CM_ResetStatCounters()`. By default `FS_MMC_ENABLE_STATS` is set to 1 if `FS_DEBUG_LEVEL` is set to a value greater than or equal to `FS_DEBUG_LEVEL_CHECK_ALL`.

6.5.3.1.1.3 FS_MMC_NUM_RETRIES

This device can be used to specify the number of times the Card Mode MMC/SD driver retries the operation in case of a read or write error.

6.5.3.1.1.4 FS_MMC_NUM_UNITS

This define specifies the maximum number of driver instances of the Card Mode MMC/SD driver the application is allowed create. Four bytes of static RAM are reserved for each instance. If the maximum number of driver instances is smaller than the default value then `FS_MMC_NUM_UNITS` can be set to the to that value in order to reduce the RAM usage.

6.5.3.1.1.5 FS_MMC_READ_DATA_TIMEOUT

`FS_MMC_READ_DATA_TIMEOUT` specifies the maximum number of milliseconds the Card Mode MMC/SD driver has to wait for the data to be received from the storage device. A value of 0 is interpreted as `0xFFFFFFFF` milliseconds for backward compatibility. Typically, a storage device requires a maximum of 200 milliseconds to complete a read operation.

6.5.3.1.1.6 FS_MMC_READ_SINGLE_LAST_SECTOR

`FS_MMC_READ_SINGLE_LAST_SECTOR` can be used to specify how the last logical sector located on the storage device has to be read. If `FS_MMC_READ_SINGLE_LAST_SECTOR` is set to 0 then the last logical sector can be read either via a command that reads one logical sector (`CMD_READ_SINGLE_BLOCK`) or via a command that reads multiple logical sectors (`CMD_READ_MULTIPLE_BLOCKS`). If `FS_MMC_READ_SINGLE_LAST_SECTOR` is set to 1 then the last logical sector is always read via a `CMD_READ_SINGLE_BLOCK` command. This feature has to be activated for a storage device that is not able to handle correctly `CMD_READ_MULTIPLE_BLOCKS` commands that read the last sector.

6.5.3.1.1.7 FS_MMC_SELECT_CARD_TIMEOUT

`FS_MMC_SELECT_CARD_TIMEOUT` specifies the maximum number of times the Card Mode MMC/SD driver has to repeat a failed card select operation before it reports an error to the Storage layer. The Card Mode MMC/SD driver selects a storage device before each data exchange operation. At the end of the operation the storage device is deselected.

6.5.3.1.1.8 FS_MMC_SUPPORT_MMC

`FS_MMC_SUPPORT_MMC` can be used to disable the handling of MMC devices in the Card Mode MMC/SD driver. If the target application is expected to work only with SD cards then this configuration define can be safely set to 0 in order to save ROM space. The handling of MMC device does not have to be explicitly enabled at runtime if `FS_MMC_SUPPORT_MMC` is set to 1.

6.5.3.1.1.9 FS_MMC_SUPPORT_POWER_SAVE

`FS_MMC_SUPPORT_POWER_SAVE` can be used to enable the support for putting MMC device into sleep mode. This feature has to be enabled at runtime by calling `FS_MMC_CM_AllowPowerSaveMode()` with the second argument set to 1. With this feature enabled the Card Mode MMC/SD driver puts the MMC device into sleep mode after each operation to preserve power. In addition, the application can explicitly put the MMC device into sleep mode by calling `FS_MMC_CM_EnterPowerSaveMode()`.

6.5.3.1.1.10 FS_MMC_SUPPORT_SD

`FS_MMC_SUPPORT_SD` can be used to disable the handling of SD cards in the Card Mode MMC/SD driver. If the target application is expected to work only with MMC devices such as eMMC then this configuration define can be safely set to 0 in order to save ROM space. The handling of SD cards does not have to be explicitly enabled at runtime if `FS_MMC_SUPPORT_SD` is set to 1.

6.5.3.1.1.11 FS_MMC_SUPPORT_TRIM

`FS_MMC_SUPPORT_TRIM` can be used to specify if the information about unused logical sectors is forward to the storage device. If `FS_MMC_SUPPORT_TRIM` is set to 1 then the storage device is informed about logical sectors that do not contain valid data anymore such as when a file is deleted. Currently, only MMC devices support this operation.

6.5.3.1.1.12 FS_MMC_SUPPORT_UHS

`FS_MMC_SUPPORT_UHS` can be used to enable the support for access modes with a clock frequency of up to about 200 MHz. Refer to *Supported hardware* on page 963 for a list of supported access modes. All ultra high speed access modes are disabled by default and have to be explicitly enabled at runtime by the application in `FS_X_AddDevices()` by calling one of the functions listed in the following table with the `OnOff` parameter set to 1.

Device type	UHS Access mode	Function name
SD	DDR50	<code>FS_MMC_CM_AllowAccessModeDDR50()</code>
SD	SDR50	<code>FS_MMC_CM_AllowAccessModeSDR50()</code>
SD	SDR104	<code>FS_MMC_CM_AllowAccessModeSDR104()</code>
MMC	High Speed DDR	<code>FS_MMC_CM_AllowAccessModeHS_DDR()</code>
MMC	HS200	<code>FS_MMC_CM_AllowAccessModeHS200()</code>
MMC	HS400	<code>FS_MMC_CM_AllowAccessModeHS400()</code>

In addition, the voltage level of the I/O lines has to be set to 1.8 V by calling the `FS_MM-C_CM_AllowVoltageLevel1V8()` with the `OnOff` parameter set to 1.

6.5.3.1.1.13 FS_MMC_TEST_BUS_WIDTH

This configuration define can be used to enable the runtime detection of the number of data signals connected to an eMMC device. If `FS_MMC_TEST_BUS_WIDTH` is set to 1 then the Card Mode MMC/SD driver requests the eMMC device to send a predefined data pattern that can be used to determine how many data signals are physically connected. This information is used by the Card Mode MMC/SD driver to configure the eMMC device for a data transfer via the maximum number of data signals available.

6.5.3.1.1.14 FS_MMC_WAIT_READY_TIMEOUT

`FS_MMC_WAIT_READY_TIMEOUT` specifies the maximum number of times the Card Mode MMC/SD driver has to check for the ready status of the storage device before it reports an error to the Storage layer.

6.5.3.1.2 Runtime configuration

The driver must be added to the file system by calling `FS_AddDevice()` with the driver identifier set to the address of `FS_MMC_CM_Driver` structure. This function call together with

other function calls that configure the driver operation have to be added to `FS_X_AddDe-`
`devices()` as demonstrated in the following example. This example shows how to configure
the file system to access an MMC/SD card in card mode.

```
#include "FS.h"
#include "FS_MMC_HW_CM_Template.h"

#define ALLOC_SIZE 0x1300           // Size defined in bytes

static U32 _aMemBlock[ALLOC_SIZE / 4]; // Memory pool used for
                                        // semi-dynamic allocation.

/*****
 *
 *      FS_X_AddDevices
 *
 *      Function description
 *      This function is called by the FS during FS_Init().
 */
void FS_X_AddDevices(void) {
    //
    // Give the file system memory to work with.
    //
    FS_AssignMemory(&_aMemBlock[0], sizeof(_aMemBlock));
    //
    // Add and configure the Card mode MMC/SD driver.
    //
    FS_AddDevice(&FS_MMC_CM_Driver);
    FS_MMC_CM_Allow4bitMode(0, 1);
    FS_MMC_CM_SetHWType(0, &FS_MMC_HW_CM_Template);
    //
    // Configure the file system for fast write operations.
    //
    #if FS_SUPPORT_FILE_BUFFER
        FS_ConfigFileBufferDefault(512, FS_FILE_BUFFER_WRITE);
    #endif
    FS_SetFileWriteMode(FS_WRITEMODE_FAST);
}
```

The API functions listed in the next table can be used by the application to configure the behavior of the Card Mode MMC/SD driver. The application can call them only at the file system initialization in `FS_X_AddDevices()`.

Function	Description
<code>FS_MMC_CM_Allow4bitMode()</code>	Allows the driver to exchange the data via 4 lines.
<code>FS_MMC_CM_Allow8bitMode()</code>	Allows the driver to exchange the data via 8 data lines.
<code>FS_MMC_CM_AllowCacheActivation()</code>	Allows the driver to activate the data cache of an eMMC device.
<code>FS_MMC_CM_AllowAccessModeDDR50()</code>	Allows the driver to exchange the data with an SD card using DDR50 access mode.
<code>FS_MMC_CM_AllowAccessModeHS200()</code>	Allows the driver to exchange the data with an MMC device using the HS200 access mode.
<code>FS_MMC_CM_AllowAccessModeHS400()</code>	Allows the driver to exchange the data with an eMMC device using the HS400 access mode.
<code>FS_MMC_CM_AllowAccessModeHS_DDR()</code>	Allows the driver to exchange the data with an MMC device using the High Speed DDR access mode.

Function	Description
<code>FS_MMC_CM_AllowAccessModeSDR104()</code>	Allows the driver to exchange the data with an SD card using SDR104 access mode.
<code>FS_MMC_CM_AllowAccessModeSDR50()</code>	Allows the driver to exchange the data with an SD card using SDR50 access mode.
<code>FS_MMC_CM_AllowBufferedWrite()</code>	Enables / disables the write buffering.
<code>FS_MMC_CM_AllowHighSpeedMode()</code>	Allows the driver to exchange the data in high speed mode.
<code>FS_MMC_CM_AllowPowerSaveMode()</code>	Configures if the driver has to request the eMMC to save power.
<code>FS_MMC_CM_AllowReliableWrite()</code>	Allows the driver to use reliable write operations for MMC devices.
<code>FS_MMC_CM_AllowVoltageLevel1V8()</code>	Allows the driver to user 1.8 V signaling on the I/O lines.
<code>FS_MMC_CM_SetDriverStrength()</code>	Configures the output driving strength of the MMC/SD device.
<code>FS_MMC_CM_SetSectorRange()</code>	Configures an area for data storage.
<code>FS_MMC_CM_SetHS200Tuning()</code>	Enables or disables the tuning for the HS200 access mode.
<code>FS_MMC_CM_SetHWType()</code>	Configures the HW access routines.
<code>FS_MMC_CM_SetSDR104Tuning()</code>	Enables or disables the tuning for the SDR104 access mode.
<code>FS_MMC_CM_SetSDR50Tuning()</code>	Enables or disables the tuning for the SDR50 access mode.

6.5.3.1.2.1 FS_MMC_CM_Allow4bitMode()

Description

Allows the driver to exchange the data via 4 lines.

Prototype

```
void FS_MMC_CM_Allow4bitMode(U8 Unit,
                             U8 OnOff);
```

Parameters

Parameter	Description
<code>Unit</code>	Index of the driver instance (0-based).
<code>OnOff</code>	Specifies the permission status. <ul style="list-style-type: none"> • 0 Data is exchanged via 1 line. • 1 Data is exchanged via 4 lines.

Additional information

This function is optional. By default, the 4-bit mode is disabled which means that the Card Mode MMC/SD driver exchanges data via only one data line. Using 4-bit mode can help increase the performance of the data transfer. The 4-bit mode is used for the data transfer only if the connected MMC/SD card supports it which is typically the case with all modern cards. If not then the Card Mode MMC/SD driver falls back to 1-bit mode.

The application can query the actual number of data lines used by the Card Mode MMC/SD driver for the data transfer by evaluating the value of `BusWith` member of the `FS_MM-C_CARD_INFO` structure returned by `FS_MMC_CM_GetCardInfo()`.

An application is permitted to call this function only at the file system initialization in `FS_X_AddDevices()`.

6.5.3.1.2.2 FS_MMC_CM_Allow8bitMode()

Description

Allows the driver to exchange the data via 8 data lines.

Prototype

```
void FS_MMC_CM_Allow8bitMode(U8 Unit,
                             U8 OnOff);
```

Parameters

Parameter	Description
<code>Unit</code>	Index of the driver instance (0-based).
<code>OnOff</code>	Specifies the permission status. <ul style="list-style-type: none"> • 0 Data is exchanged via 1 or 4 lines. • 1 Data is exchanged via 8 lines.

Additional information

This function is optional. By default, the 8-bit mode is disabled which means that the Card Mode MMC/SD driver exchanges data via only one data line. Using 8-bit mode can help increase the performance of the data transfer. The 8-bit mode is used for the data transfer only if the connected MMC/SD card supports it. If not then the Card mode MMC/SD driver falls back to either 4- or 1-bit mode. Only MMC devices support the 8-bit mode. The SD cards are not able to transfer the data via 8-bit lines.

The application can query the actual number of data lines used by the Card Mode MMC/SD driver for the data transfer by evaluating the value of `BusWith` member of the `FS_MM-C_CARD_INFO` structure returned by `FS_MMC_CM_GetCardInfo()`.

An application is permitted to call this function only at the file system initialization in `FS_X_AddDevices()`.

6.5.3.1.2.3 FS_MMC_CM_AllowCacheActivation()

Description

Allows the driver to activate the data cache of an eMMC device.

Prototype

```
void FS_MMC_CM_AllowCacheActivation(U8 Unit,  
                                     U8 OnOff);
```

Parameters

Parameter	Description
<code>Unit</code>	Index of the driver instance (0-based).
<code>OnOff</code>	Specifies the permission status. <ul style="list-style-type: none">• 0 Cache activation is not allowed.• 1 Cache activation is allowed.

Additional information

This function is optional. It can be used to configure if the Card Mode MMC/SD driver is allowed to enable the data cache of an eMMC device. The data cache is activated only if supported by the eMMC device. By default, the Card Mode MMC/SD driver activates the data cache for improved read and write performance. With the data cache enabled, the fail-safety of the file system can no longer be guaranteed.

An application is permitted to call this function only at the file system initialization in `FS_X_AddDevices()`.

`FS_MMC_CM_AllowCacheActivation()` is available only when the file system is built with `FS_MMC_SUPPORT_MMC` set to 1.

6.5.3.1.2.4 FS_MMC_CM_AllowAccessModeDDR50()

Description

Allows the driver to exchange the data with an SD card using DDR50 access mode.

Prototype

```
void FS_MMC_CM_AllowAccessModeDDR50(U8 Unit,
                                     U8 OnOff);
```

Parameters

Parameter	Description
<code>Unit</code>	Index of the driver instance (0-based).
<code>OnOff</code>	Specifies the permission status. <ul style="list-style-type: none"> • 0 Use another access mode. • 1 Use DDR50 access mode.

Additional information

This function is optional. The application can use it to request the Card Mode MMC/SD driver to exchange data with an SD card on both clock edges and at a clock frequency of maximum 50 MHz. The voltage level of the I/O lines used by this access mode is 1.8 V. The support for the 1.8 V voltage level can be enabled vis `FS_MMC_CM_AllowVoltageLevel1V8()`. The DDR50 access mode is used only if the connected SD card supports it.

The application can check if the Card Mode MMC/SD driver is actually using the DDR50 access mode for the data transfer by evaluating the `AccessMode` member of the `FS_MM-C_CARD_INFO` structure returned by `FS_MMC_CM_GetCardInfo()`.

The DDR50 access mode can be used only if the SD/MMC host controller supports it. The availability of this functionality is not checked by the Card Mode MMC/SD driver.

An application is permitted to call this function only at the file system initialization in `FS_X_AddDevices()`.

`FS_MMC_CM_AllowAccessModeDDR50()` is available only when the file system is built with `FS_MMC_SUPPORT_UHS` and `FS_MMC_SUPPORT_SD` set to 1.

6.5.3.1.2.5 FS_MMC_CM_AllowAccessModeHS200()

Description

Allows the driver to exchange the data with an MMC device using the HS200 access mode.

Prototype

```
void FS_MMC_CM_AllowAccessModeHS200(U8 Unit,
                                     U8 OnOff);
```

Parameters

Parameter	Description
<code>Unit</code>	Index of the driver instance (0-based).
<code>OnOff</code>	Specifies the permission status. <ul style="list-style-type: none"> • 0 Use another access mode. • 1 Use HS200 access mode.

Additional information

This function is optional. The application can use it to request the Card Mode MMC/SD driver to exchange data with an MMC device on a single clock edge and at a clock frequency of maximum 200 MHz. The voltage level of the I/O lines used by this access mode can be either 1.8 V. The support for the 1.8 V voltage level can be enabled via `FS_MMC_CM_AllowVoltageLevel1V8()`. The HS200 access mode is used only if the connected MMC device supports it. In this access mode the data is transferred either via 4 or 8 lines. The data transfer via 4 and 8 data lines can be enabled via `FS_MMC_CM_Allow4bitMode()` and `FS_MMC_CM_Allow8bitMode()` respectively.

The application can check if the Card Mode MMC/SD driver is actually using the HS200 access mode for the data transfer by evaluating the `AccessMode` member of the `FS_MMC_C_CARD_INFO` structure returned by `FS_MMC_CM_GetCardInfo()`.

The HS200 access mode can be used only if the SD/MMC host controller supports it. The availability of this functionality is not checked by the Card Mode MMC/SD driver.

An application is permitted to call this function only at the file system initialization in `FS_X_AddDevices()`.

`FS_MMC_CM_AllowAccessModeHS200()` is available only when the file system is built with `FS_MMC_SUPPORT_UHS` and `FS_MMC_SUPPORT_MMC` set to 1.

6.5.3.1.2.6 FS_MMC_CM_AllowAccessModeHS400()

Description

Allows the driver to exchange the data with an eMMC device using the HS400 access mode.

Prototype

```
void FS_MMC_CM_AllowAccessModeHS400(U8 Unit,
                                     U8 OnOff);
```

Parameters

Parameter	Description
<code>Unit</code>	Index of the driver instance (0-based).
<code>OnOff</code>	Specifies the permission status. <ul style="list-style-type: none"> • 0 Use another access mode. • 1 Use HS400 access mode.

Additional information

This function is optional. The application can use it to request the Card Mode MMC/SD driver to exchange data with an MMC device on both clock edges and at a clock frequency of maximum 200 MHz. The voltage level of the I/O lines used by this access mode can be either 1.8 V. The support for the 1.8 V voltage level can be enabled via `FS_MMC_CM_AllowVoltageLevel1V8()`. The HS400 access mode is used only if the connected MMC device supports it. In this access mode the data is always transferred via 8 lines. The data transfer via 8 data lines can be enabled via `FS_MMC_CM_Allow8bitMode()`.

The application can check if the Card Mode MMC/SD driver is actually using the HS400 access mode for the data transfer by evaluating the `AccessMode` member of the `FS_MM-C_CARD_INFO` structure returned by `FS_MMC_CM_GetCardInfo()`.

The HS400 access mode can be used only if the SD/MMC host controller supports it. The availability of this functionality is not checked by the Card Mode MMC/SD driver.

An application is permitted to call this function only at the file system initialization in `FS_X_AddDevices()`.

`FS_MMC_CM_AllowAccessModeHS400()` is available only when the file system is built with `FS_MMC_SUPPORT_UHS` and `FS_MMC_SUPPORT_MMC` set to 1.

6.5.3.1.2.7 FS_MMC_CM_AllowAccessModeHS_DDR()

Description

Allows the driver to exchange the data with an MMC device using the High Speed DDR access mode.

Prototype

```
void FS_MMC_CM_AllowAccessModeHS_DDR(U8 Unit,
                                     U8 OnOff);
```

Parameters

Parameter	Description
<code>Unit</code>	Index of the driver instance (0-based).
<code>OnOff</code>	Specifies the permission status. <ul style="list-style-type: none"> • 0 Use another access mode. • 1 Use High Speed DRR access mode.

Additional information

This function is optional. The application can use it to request the Card Mode MMC/SD driver to exchange data with an MMC device on both clock edges and at a clock frequency of maximum 52 MHz. The voltage level of the I/O lines used by this access mode can be either 3.3 V or 1.8 V. The support for the 1.8 V voltage level can be enabled via `FS_MMC_CM_AllowVoltageLevel1V8()`. The 3.3 V voltage level is enabled by default. The High Speed DDR access mode is used only if the connected MMC device supports it.

The application can check if the Card Mode MMC/SD driver is actually using the high speed DDR access mode for the data transfer by evaluating the `AccessMode` member of the `FS_MMC_CM_CARD_INFO` structure returned by `FS_MMC_CM_GetCardInfo()`.

The High Speed DDR access mode can be used only if the SD/MMC host controller supports it. The availability of this functionality is not checked by the Card Mode MMC/SD driver.

An application is permitted to call this function only at the file system initialization in `FS_X_AddDevices()`.

`FS_MMC_CM_AllowAccessModeHS_DDR()` is available only when the file system is built with `FS_MMC_SUPPORT_UHS` and `FS_MMC_SUPPORT_MMC` set to 1.

6.5.3.1.2.8 FS_MMC_CM_AllowAccessModeSDR104()

Description

Allows the driver to exchange the data with an SD card using SDR104 access mode.

Prototype

```
void FS_MMC_CM_AllowAccessModeSDR104(U8 Unit,
                                       U8 OnOff);
```

Parameters

Parameter	Description
<code>Unit</code>	Index of the driver instance (0-based).
<code>OnOff</code>	Specifies the permission status. <ul style="list-style-type: none"> • 0 Use another access mode. • 1 Use SDR104 access mode.

Additional information

This function is optional. The application can use it to request the Card Mode MMC/SD driver to exchange data with an SD card on a single clock edge and at a clock frequency of maximum 208 MHz. The voltage level of the I/O lines used by this access mode is 1.8 V. The support for the 1.8 V voltage level can be enabled vis `FS_MMC_CM_AllowVoltageLevel1V8()`. The SDR104 access mode is used only if the connected SD card supports it.

The application can check if the Card Mode MMC/SD driver is actually using the SDR104 access mode for the data transfer by evaluating the `AccessMode` member of the `FS_MM-C_CARD_INFO` structure returned by `FS_MMC_CM_GetCardInfo()`.

The SDR104 access mode can be used only if the SD/MMC host controller supports it. The availability of this functionality is not checked by the Card Mode MMC/SD driver.

An application is permitted to call this function only at the file system initialization in `FS_X_AddDevices()`.

`FS_MMC_CM_AllowAccessModeSDR104()` is available only when the file system is built with `FS_MMC_SUPPORT_UHS` and `FS_MMC_SUPPORT_SD` set to 1.

6.5.3.1.2.9 FS_MMC_CM_AllowAccessModeSDR50()

Description

Allows the driver to exchange the data with an SD card using SDR50 access mode.

Prototype

```
void FS_MMC_CM_AllowAccessModeSDR50(U8 Unit,
                                     U8 OnOff);
```

Parameters

Parameter	Description
<code>Unit</code>	Index of the driver instance (0-based).
<code>OnOff</code>	Specifies the permission status. <ul style="list-style-type: none"> • 0 Use another access mode. • 1 Use SDR50 access mode.

Additional information

This function is optional. The application can use it to request the Card Mode MMC/SD driver to exchange data with an SD card on a single clock edge and at a clock frequency of maximum 100 MHz. The voltage level of the I/O lines used by this access mode is 1.8 V. The support for the 1.8 V voltage level can be enabled via `FS_MMC_CM_AllowVoltageLevel1V8()`. The SDR50 access mode is used only if the connected SD card supports it.

The application can check if the Card Mode MMC/SD driver is actually using the SDR50 access mode for the data transfer by evaluating the `AccessMode` member of the `FS_MM-C_CARD_INFO` structure returned by `FS_MMC_CM_GetCardInfo()`.

The SDR50 access mode can be used only if the SD/MMC host controller supports it. The availability of this functionality is not checked by the Card Mode MMC/SD driver.

An application is permitted to call this function only at the file system initialization in `FS_X_AddDevices()`.

`FS_MMC_CM_AllowAccessModeSDR50()` is available only when the file system is built with `FS_MMC_SUPPORT_UHS` and `FS_MMC_SUPPORT_SD` set to 1.

6.5.3.1.2.10 FS_MMC_CM-AllowBufferedWrite()

Description

Enables / disables the write buffering.

Prototype

```
void FS_MMC_CM-AllowBufferedWrite(U8 Unit,
                                   U8 OnOff);
```

Parameters

Parameter	Description
<code>Unit</code>	Index of the driver instance (0-based).
<code>OnOff</code>	Specifies if the buffered write operation should be enabled or not. <ul style="list-style-type: none"> • 0 Buffered write operation is disabled. • 1 BUffered write operation is enabled.

Additional information

SD and MMC storage devices can perform write operations in parallel to receiving data from the host by queuing write requests. This feature is used by the driver in order to achieve the highest write performance possible. In case of a power fail the hardware has to prevent that the write operation is interrupted by powering the storage device until the write queue is emptied. The time it takes the storage device to empty the queue is not predictable and it can take from a few hundreds o milliseconds to a few seconds to complete. This function allows the application to disable the buffered write and thus reduce the time required to supply the storage device at power fail. With the write buffering disabled the driver writes only one sector at time and it waits for the previous write sector operation to complete.

Disabling the write buffering can considerably reduce the write performance. Most of the industrial grade SD and MMC storage devices are fail safe so that disabling the write buffering is not required. For more information consult the data sheet of your storage device.

An application is permitted to call this function only at the file system initialization in `FS_X_AddDevices()`.

6.5.3.1.2.11 FS_MMC_CM_AllowHighSpeedMode()

Description

Allows the driver to exchange the data in high speed mode.

Prototype

```
void FS_MMC_CM_AllowHighSpeedMode(U8 Unit,
                                   U8 OnOff);
```

Parameters

Parameter	Description
<code>Unit</code>	Index of the driver instance (0-based).
<code>OnOff</code>	Specifies the permission status. <ul style="list-style-type: none"> • 0 Use standard speed mode. • 1 Use high speed mode.

Additional information

This function is optional. The application can use this function to request the Card Mode MMC/SD driver to use the highest clock frequency supported by the used MMC/SD card. The standard clock frequency supported by an SD card is 25 MHz and 26 MHz by an MMC device. This is the clock frequency used by the Card Mode MMC/SD driver after the initialization of the MMC/SD card. However, most of the modern SD cards and MMC devices are able to exchange the data at higher clock frequencies up to 50 MHz for SD cards and 52 MHz for MMC devices. This high speed mode has to be explicitly enabled in the SD card or MMC device after initialization. The Card mode SD/MMC driver automatically enables the high speed mode in the SD card or MMC device if `FS_MMC_CM_AllowHighSpeedMode()` is called with `OnOff` set to 1 and the used SD card or MMC device actually supported.

The application can check if the Card Mode MMC/SD driver is actually using the high speed mode for the data transfer by evaluating the `IsHighSpeedMode` member of the `FS_MM-C_CARD_INFO` structure returned by `FS_MMC_CM_GetCardInfo()`.

The high speed mode can be used only if the SD/MMC host controller supports it. The availability of this functionality is not checked by the Card Mode MMC/SD driver.

An application is permitted to call this function only at the file system initialization in `FS_X_AddDevices()`.

6.5.3.1.2.12 FS_MMC_CM-AllowPowerSaveMode()

Description

Configures if the driver has to request the eMMC to save power.

Prototype

```
int FS_MMC_CM-AllowPowerSaveMode(U8 Unit,  
                                  U8 OnOff);
```

Parameters

Parameter	Description
<code>Unit</code>	Index of the driver instance (0-based).
<code>OnOff</code>	Specifies if the MMC device has to be put to sleep between data transfers <ul style="list-style-type: none">• 0 The MMC device remains active.• 1 The MMC device is put to sleep.

Return value

= 0 OK, feature configured.
≠ 0 An error occurred.

Additional information

This function is optional and active only if the sources are compiled with the `FS_MMC_SUPPORT_POWER_SAVE` set to 1.

6.5.3.1.2.13 FS_MMC_CM-AllowReliableWrite()

Description

Allows the driver to use reliable write operations for MMC devices.

Prototype

```
void FS_MMC_CM-AllowReliableWrite(U8 Unit,
                                   U8 OnOff);
```

Parameters

Parameter	Description
<code>Unit</code>	Index of the driver instance (0-based).
<code>OnOff</code>	Specifies the permission status. <ul style="list-style-type: none"> • 0 Reliable write operation is disabled (default). • 1 Reliable write operation is enabled.

Additional information

This function is optional. A reliable write operation makes sure that the sector data is not corrupted in case of a unexpected reset. MMC devices compliant with the version 4.3 or newer of the MMC specification support a fail-safe write feature which makes sure that the old data remains unchanged until the new data is successfully programmed. Using this type of write operation the data remains valid in case of an unexpected reset which improves the data reliability. The support for this feature is optional and the Card Mode MMC/SD driver activates it only if the used MMC device actually supports it and it `FS_MMC_CM-AllowReliableWrite()` has been called with `OnOff` set to 1.

Enabling the reliable write feature can possibly reduce the write performance.

An application is permitted to call this function only at the file system initialization in `FS_X_AddDevices()`.

6.5.3.1.2.14 FS_MMC_CM_AllowVoltageLevel1V8()

Description

Allows the driver to user 1.8 V signaling on the I/O lines.

Prototype

```
void FS_MMC_CM_AllowVoltageLevel1V8(U8 Unit,
                                     U8 OnOff);
```

Parameters

Parameter	Description
<code>Unit</code>	Index of the driver instance (0-based).
<code>OnOff</code>	Specifies the permission status. <ul style="list-style-type: none"> • 0 1.8 V signaling is not allowed. • 1 1.8 V signaling is allowed.

Additional information

This function is optional. It gives the application the ability to configure if the Card Mode MMC/SD driver can exchange the data with an SD card or MMC device using 1.8 V voltage level on the I/O lines. This voltage level is required for the ultra high speed access modes.

An application is permitted to call this function only at the file system initialization in `FS_X_AddDevices()`.

`FS_MMC_CM_AllowVoltageLevel1V8()` is available only when the file system is built with `FS_MMC_SUPPORT_UHS` set to 1.

6.5.3.1.2.15 FS_MMC_CM_SetDriverStrength()

Description

Configures the output driving strength of the MMC/SD device.

Prototype

```
void FS_MMC_CM_SetDriverStrength(U8 Unit,
                                unsigned DriverStrength);
```

Parameters

Parameter	Description
<code>Unit</code>	Index of the driver instance (0-based).
<code>DriverStrength</code>	Specifies the output driving strength.

Additional information

This function is optional. It gives the application the ability to configure if the output driving strength of the MMC/SD device. Refer to *Driver strength types* on page 1005 for permitted values for `DriverStrength`. The specified driver strength is used only if the MMC/SD device actually supports it. If the MMC/SD device does not support the specified driver strength then the default driver strength is used.

The actual driver strength can be queried via `FS_MMC_CM_GetCardInfo()`. The value is stored in the `FS_MMC_CARD_INFO::DriverStrength` member of the returned data structure.

An application is permitted to call this function only at the file system initialization in `FS_X_AddDevices()`.

`FS_MMC_CM_SetDriverStrength()` is available only when the file system is built with `FS_MMC_SUPPORT_UHS` set to 1.

6.5.3.1.2.16 FS_MMC_CM_SetSectorRange()

Description

Configures an area for data storage.

Prototype

```
void FS_MMC_CM_SetSectorRange(U8 Unit,
                              U32 StartSector,
                              U32 MaxNumSectors);
```

Parameters

Parameter	Description
Unit	Index of the driver instance (0-based).
StartSector	Index of the first sector to be used as storage.
MaxNumSectors	Maximum number of sectors to be used as storage.

Additional information

This function is optional. It allows an application to use only a specific area of an SD/MMC storage device as storage. By default the Card Mode MMC/SD driver uses the entire available space as storage.

[StartSector](#) is relative to the beginning of the SD/MMC storage device. For example, if [StartSector](#) is set to 3 then the sectors with the indexes 0, 1, and 2 are not used for storage. The initialization of SD/MMC storage device fails if [StartSector](#) is out of range.

If [MaxNumSectors](#) is set to 0 the Card mode SD/MMC driver uses for storage the remaining sectors starting from [StartSector](#). If [MaxNumSectors](#) is larger than the available number of sectors the actual number of sectors used for storage is limited to the number of sectors available.

6.5.3.1.2.17 FS_MMC_CM_SetHS200Tuning()

Description

Enables or disables the tuning for the HS200 access mode.

Prototype

```
void FS_MMC_CM_SetHS200Tuning(U8 Unit,
                              U8 OnOff);
```

Parameters

Parameter	Description
<code>Unit</code>	Index of the driver instance (0-based).
<code>OnOff</code>	Specifies the tuning activation status. <ul style="list-style-type: none"> • 0 Tuning is not performed. • 1 Tuning is performed.

Additional information

This function is optional. It gives the application the ability to select if a tuning procedure is performed at the initialization of an MMC device that is exchanging the data in HS200 access mode. The tuning procedure is required in order to determine the correct sampling point of the data that is received from the SD card. By default, the tuning procedure is enabled for the HS200 access mode.

An application is permitted to call this function only at the file system initialization in `FS_X_AddDevices()`.

`FS_MMC_CM_SetHS200Tuning()` is available only when the file system is built with `FS_MM-C_SUPPORT_UHS` and `FS_MMC_SUPPORT_MMC` set to 1.

6.5.3.1.2.18 FS_MMC_CM_SetHWType()

Description

Configures the HW access routines.

Prototype

```
void FS_MMC_CM_SetHWType(          U8          Unit,
                             const FS_MMC_HW_TYPE_CM * pHWType);
```

Parameters

Parameter	Description
<code>Unit</code>	Index of the driver instance (0-based).
<code>pHWType</code>	in Specifies the type of the hardware layer to be used to communicate with the storage device.

Additional information

This function is mandatory. It has to be called in `FS_X_AddDevices()` once for each instance of the card mode SD/MMC driver. The driver instance is identified by the `Unit` parameter.

6.5.3.1.2.19 FS_MMC_CM_SetSDR104Tuning()

Description

Enables or disables the tuning for the SDR104 access mode.

Prototype

```
void FS_MMC_CM_SetSDR104Tuning(U8 Unit,
                               U8 OnOff);
```

Parameters

Parameter	Description
<code>Unit</code>	Index of the driver instance (0-based).
<code>OnOff</code>	Specifies the tuning activation status. <ul style="list-style-type: none"> • 0 Tuning is not performed. • 1 Tuning is performed.

Additional information

This function is optional. It gives the application the ability to select if a tuning procedure is performed at the initialization of the SD card that is exchanging the data in SDR104 access mode. The tuning procedure is required in order to determine the correct sampling point of the data that is received from the SD card. By default, the tuning procedure is enabled for the SDR104 access mode as required by the SD Specification.

An application is permitted to call this function only at the file system initialization in `FS_X_AddDevices()`.

`FS_MMC_CM_SetSDR104Tuning()` is available only when the file system is built with `FS_MM-C_SUPPORT_UHS` and `FS_MMC_SUPPORT_SD` set to 1.

6.5.3.1.2.20 FS_MMC_CM_SetSDR50Tuning()

Description

Enables or disables the tuning for the SDR50 access mode.

Prototype

```
void FS_MMC_CM_SetSDR50Tuning(U8 Unit,
                              U8 OnOff);
```

Parameters

Parameter	Description
<code>Unit</code>	Index of the driver instance (0-based).
<code>OnOff</code>	Specifies the tuning activation status. <ul style="list-style-type: none"> • 0 Tuning is not performed. • 1 Tuning is performed.

Additional information

This function is optional. It gives the application the ability to select if a tuning procedure is performed at the initialization of the SD card that is exchanging the data in SDR50 access mode. The tuning procedure is required in order to determine the correct sampling point of the data that is received from the SD card. By default, the tuning procedure is disabled for the SDR50 access mode.

An application is permitted to call this function only at the file system initialization in `FS_X_AddDevices()`.

`FS_MMC_CM_SetSDR50Tuning()` is available only when the file system is built with `FS_MM-C_SUPPORT_UHS` and `FS_MMC_SUPPORT_SD` set to 1.

6.5.3.1.2.21 Driver strength types

Description

Types of output driver strengths of an MMC/SD storage device.

Definition

```
#define FS_MMC_DRIVER_STRENGTH_TYPE_B 0u
#define FS_MMC_DRIVER_STRENGTH_TYPE_A 1u
#define FS_MMC_DRIVER_STRENGTH_TYPE_C 2u
#define FS_MMC_DRIVER_STRENGTH_TYPE_D 3u
#define FS_MMC_DRIVER_STRENGTH_TYPE_E 4u
```

Symbols

Definition	Description
<code>FS_MM-C_DRIVER_STRENGTH_TYPE_B</code>	50 Ohm impedance and x1 driving capability. This is the default value.
<code>FS_MM-C_DRIVER_STRENGTH_TYPE_A</code>	33 Ohm impedance and x1.5 driving capability.
<code>FS_MM-C_DRIVER_STRENGTH_TYPE_C</code>	66 Ohm impedance and x0.75 driving capability.
<code>FS_MM-C_DRIVER_STRENGTH_TYPE_D</code>	100 Ohm impedance and x0.5 driving capability.
<code>FS_MM-C_DRIVER_STRENGTH_TYPE_E</code>	40 Ohm impedance and x1.2 driving capability. For eMMC devices only.

6.5.3.2 Additional driver functions

These functions are optional. They can be used to get information about the operation of the Card Mode MMC/SD driver and to perform additional operations on the used SD card or MMC device.

Function	Description
<code>FS_MMC_CM_EnterPowerSaveMode()</code>	Puts the MMC to sleep in order to save power.
<code>FS_MMC_CM_Erase()</code>	Erases the contents of one or more logical sectors.
<code>FS_MMC_CM_GetCardId()</code>	Returns the identification data of the SD/MMC device.
<code>FS_MMC_CM_GetCardInfo()</code>	This function returns information about the SD/MMC device.
<code>FS_MMC_CM_GetStatCounters()</code>	Returns the value of statistical counters.
<code>FS_MMC_CM_ReadCSD()</code>	Reads the contents of the CSD register of a storage device.
<code>FS_MMC_CM_ReadExtCSD()</code>	Reads the contents of the Extended CSD register of an MMC device.
<code>FS_MMC_CM_ReadGeneral()</code>	Reads a block of data via General Command (CMD56).
<code>FS_MMC_CM_ReadSectors()</code>	Reads blocks of data from the active partition of the storage card.
<code>FS_MMC_CM_ResetStatCounters()</code>	Sets to 0 all statistical counters.
<code>FS_MMC_CM_UnlockCardForced()</code>	Unlocks an SD card.
<code>FS_MMC_CM_WriteExtCSD()</code>	Writes to the Extended CSD register of a MMC device.

Function	Description
<code>FS_MMC_CM_WriteGeneral()</code>	Writes a block of data via General Command (CMD56).
<code>FS_MMC_CM_WriteSectors()</code>	Writes blocks of data to the selected partition of the storage card.

6.5.3.2.1 FS_MMC_CM_EnterPowerSaveMode()

Description

Puts the MMC to sleep in order to save power.

Prototype

```
int FS_MMC_CM_EnterPowerSaveMode(U8 Unit);
```

Parameters

Parameter	Description
Unit	Index of the driver instance (0-based).

Return value

= 0 The eMMC device is in Sleep state.
≠ 0 An error occurred.

Additional information

This function is optional. It can be used to explicitly put the eMMC device into Sleep state in order to reduce power consumption.

This function is active only if the sources are compiled with the define `FS_MMC_SUPPORT_POWER_SAVE` set to 1.

6.5.3.2.2 FS_MMC_CM_Erase()

Description

Erases the contents of one or more logical sectors.

Prototype

```
int FS_MMC_CM_Erase(U8 Unit,
                   U32 StartSector,
                   U32 NumSectors);
```

Parameters

Parameter	Description
<code>Unit</code>	Index of the driver instance (0-based).
<code>StartSector</code>	Index of the first sector to be erased.
<code>NumSectors</code>	Number of sector to be erased.

Return value

= 0 Sectors erased.
 ≠ 0 An error has occurred.

Additional information

This function is optional. The application can use it to set the contents of the specified logical sectors to a predefined value. The erase operation sets all the bits in the specified logical sectors either to 1 or to 0. The actual value is implementation defined in the `EXT_CSD` register.

The erase operation is supported only for MMC devices.

6.5.3.2.3 FS_MMC_CM_GetCardId()

Description

Returns the identification data of the SD/MMC device.

Prototype

```
int FS_MMC_CM_GetCardId(U8 Unit,
                        FS_MMC_CARD_ID * pCardId);
```

Parameters

Parameter	Description
Unit	Index of the driver instance (0-based).
pCardId	out Card identification data.

Return value

= 0 CardId has been read.
 ≠ 0 An error has occurred.

Additional information

This function is optional. The application can call this function to get the information stored in the CID register of an MMC or SD card. The CID register stores information which can be used to uniquely identify the card such as serial number, product name, manufacturer id, etc. For more information about the information stored in this register refer to SD or MMC specification. The data of the CID register starts at byte offset 1 in `pCardId->aData`.

Example

The following example shows how to read and decode the contents of the CID register.

```
#include <stdio.h>
#include "FS.h"

void SampleMMC_CMGetCardId(void) {
    U8      ManId;
    char    acOEMId[2 + 1];
    char    acProductName[5 + 1];
    U8      ProductRevMajor;
    U8      ProductRevMinor;
    U32     ProductSN;
    U8      MfgMonth;
    U16     MfgYear;
    U16     MfgDate;
    U8      * p;
    MMC_CARD_ID CardId;
    char    ac[100];

    FS_MEMSET(&CardId, 0, sizeof(CardId));
    FS_MMC_CM_GetCardId(0, &CardId);
    p = CardId.aData;
    ++p; // Skip the start of message.
    ManId = *p++;
    strncpy(acOEMId, (char *)p, 2);
    acOEMId[2] = '\0';
    p += 2;
    strncpy(acProductName, (char *)p, 5);
    acProductName[5] = '\0';
    p += 5;
    ProductRevMajor = *p >> 4;
    ProductRevMinor = *p++ & 0xF;
    ProductSN = (U32)*p++ << 24;
    ProductSN |= (U32)*p++ << 16;
    ProductSN |= (U32)*p++ << 8;
    ProductSN |= (U32)*p++;
    MfgDate = (U16)*p++;
```

```
MfgDate      |= (U16)*p++;
MfgMonth     = (U8)(MfgDate & 0xF);
MfgYear      = MfgDate >> 4;
FS_X_Log("SD card identification:\n");
SEgger_printf(ac, sizeof(ac), " Manufacturer Id:      0x%02x\n", ManId);
FS_X_Log(ac);
SEgger_printf(ac, sizeof(ac), " OEM/Application Id:   %s\n", acOEMId);
FS_X_Log(ac);
SEgger_printf(ac, sizeof(ac), " Product name:        %s\n", acProductName);
FS_X_Log(ac);
SEgger_printf(ac, sizeof(ac), " Product revision:    %lu.%lu
\n", (U32)ProductRevMajor, (U32)ProductRevMinor);
FS_X_Log(ac);
SEgger_printf(ac, sizeof(ac), " Product serial number: 0x%08lx\n", ProductSN);
FS_X_Log(ac);
SEgger_printf(ac, sizeof(ac), " Manufacturing date:   %lu-%lu
\n", (U32)MfgMonth, (U32)MfgYear);
FS_X_Log(ac);
}
```

6.5.3.2.4 FS_MMC_CM_GetCardInfo()

Description

This function returns information about the SD/MMC device.

Prototype

```
int FS_MMC_CM_GetCardInfo(U8 Unit,
                          FS_MMC_CARD_INFO * pCardInfo);
```

Parameters

Parameter	Description
Unit	Index of the driver instance (0-based).
pCardInfo	out Information about the device.

Return value

= 0 Card information returned.
 ≠ 0 An error has occurred.

Additional information

This function is optional. It can be used to get information about the type of the storage card used, about how many data lines are used for the data transfer, etc.

Example

The following example shows how to get information about the storage device.

```
#include <stdio.h>
#include "FS.h"

void SampleMMC_CMGetCardInfo(void) {
    FS_MMC_CARD_INFO CardInfo;
    const char * sCardType;
    char ac[100];
    const char * sAccessMode;

    FS_MEMSET(&CardInfo, 0, sizeof(CardInfo));
    FS_MMC_CM_GetCardInfo(0, &CardInfo);
    switch (CardInfo.CardType) {
        case FS_MMC_CARD_TYPE_MMC:
            sCardType = "MMC";
            break;
        case FS_MMC_CARD_TYPE_SD:
            sCardType = "SD";
            break;
        case FS_MMC_CARD_TYPE_UNKNOWN:
            // through
        default:
            sCardType = "UNKNOWN";
            break;
    }
    switch (CardInfo.AccessMode) {
        case FS_MMC_ACCESS_MODE_DS:
            sAccessMode = "DS";
            break;
        case FS_MMC_ACCESS_MODE_HS:
            sAccessMode = "HS";
            break;
        case FS_MMC_ACCESS_MODE_SDR50:
            sAccessMode = "SDR50";
            break;
        case FS_MMC_ACCESS_MODE_DDR50:
            sAccessMode = "DDR50";
            break;
        case FS_MMC_ACCESS_MODE_SDR104:
            sAccessMode = "SDR104";
    }
}
```

```

    break;
case FS_MMC_ACCESS_MODE_HS_DDR:
    sAccessMode = "HS_DDR";
    break;
case FS_MMC_ACCESS_MODE_HS200:
    sAccessMode = "HS200";
    break;
case FS_MMC_ACCESS_MODE_HS400:
    sAccessMode = "HS400";
    break;
case FS_MMC_ACCESS_MODE_UNKNOWN:
    // through
default:
    sAccessMode = "UNKNOWN";
    break;
}
FS_X_Log("Card information:\n");
SEGGER_sprintf(ac, sizeof(ac), " Card type:           %s\n", sCardType);
FS_X_Log(ac);
SEGGER_sprintf(ac, sizeof(ac), " Bus width:           %d line(s)\n", CardInfo.BusWidth);
FS_X_Log(ac);
SEGGER_sprintf(ac, sizeof(ac), " Write protected:    %s\n",
    CardInfo.IsWriteProtected ? "yes" : "no");
FS_X_Log(ac);
SEGGER_sprintf(ac, sizeof(ac), " High speed mode:    %s\n",
    CardInfo.IsHighSpeedMode ? "yes" : "no");
FS_X_Log(ac);
SEGGER_sprintf(ac, sizeof(ac), " Bytes per sector:   %d\n",
    (int)CardInfo.BytesPerSector);
FS_X_Log(ac);
SEGGER_sprintf(ac, sizeof(ac), " Number of sectors:  %lu\n", CardInfo.NumSectors);
FS_X_Log(ac);
SEGGER_sprintf(ac, sizeof(ac), " Clock frequency:    %lu Hz\n", CardInfo.ClockFreq);
FS_X_Log(ac);
SEGGER_sprintf(ac, sizeof(ac), " Voltage level:      %d.%d V\n",
    (int)CardInfo.VoltageLevel / 1000, (int)CardInfo.VoltageLevel % 1000 / 100);
FS_X_Log(ac);
SEGGER_sprintf(ac, sizeof(ac), " Access mode:        %s\n", sAccessMode);
FS_X_Log(ac);
SEGGER_sprintf(ac, sizeof(ac), " Driver strength:    %d\n",
    (int)CardInfo.DriverStrength);
FS_X_Log(ac);
}

```

6.5.3.2.5 FS_MMC_CM_GetStatCounters()

Description

Returns the value of statistical counters.

Prototype

```
void FS_MMC_CM_GetStatCounters(U8 Unit,
                               FS_MMC_STAT_COUNTERS * pStat);
```

Parameters

Parameter	Description
<code>Unit</code>	Index of the driver instance (0-based).
<code>pStat</code>	out Current value of statistical counters.

Additional information

This function is optional. The Card mode SD/MMC driver collects statistics about the number of internal operations such as the number of logical sectors read or written by the file system layer. The application can use `FS_MMC_CM_GetStatCounters()` to get the current value of these counters. The statistical counters are automatically set to 0 when the storage device is mounted or when the application calls `FS_MMC_CM_ResetStatCounters()`.

The statistical counters are available only when the file system is compiled with `FS_DEBUG_LEVEL` greater than or equal to `FS_DEBUG_LEVEL_CHECK_ALL` or with `FS_MMC_ENABLE_STATS` set to 1.

6.5.3.2.6 FS_MMC_CM_ReadCSD()

Description

Reads the contents of the CSD register of a storage device.

Prototype

```
int FS_MMC_CM_ReadCSD(U8 Unit,
                     U8 * pData);
```

Parameters

Parameter	Description
<code>Unit</code>	Index of the driver instance (0-based).
<code>pData</code>	<code>out</code> Contents of the CSD register.

Return value

= 0 Register contents returned.
 ≠ 0 An error has occurred.

Additional information

This function is optional. It can be used to read the information stored in the Card-Specific Register that is found in any SD card or MMC device. For more information about the contents of the CSD register refer to the SD specification.

`pData` has to be at least 16 bytes large.

Bit 127 of CSD is returned in bit 7 of `pData[0]` byte. Bit 0 of CSD is returned in bit 0 of `pData[15]` byte. Typically, an SD host controller sets to 0 the CRC bits (CSD bits 1-7) and the CSD bit 0.

6.5.3.2.7 FS_MMC_CM_ReadExtCSD()

Description

Reads the contents of the Extended CSD register of an MMC device.

Prototype

```
int FS_MMC_CM_ReadExtCSD(U8 Unit,
                        U32 * pData);
```

Parameters

Parameter	Description
<code>Unit</code>	Index of the driver instance (0-based).
<code>pData</code>	<code>out</code> Contents of the Extended CSD register.

Return value

= 0 Register contents returned.
 ≠ 0 An error has occurred.

Additional information

This function is optional. For more information about the contents of the Extended CSD register refer to the MMC specification. The contents of the Extended CSD register can be modified via `FS_MMC_CM_WriteExtCSD()`.

`pData` has to be at least 512 bytes large.

Example

The following example shows how to read data from the Extended CSD register of an MMC device.

```
#include "FS.h"

void SampleMMC_CMReadExtCSD(void) {
    U32 aExtCSD[512 / 4];
    U8 * pData8;
    int r;
    char ac[100];

    FS_MEMSET(aExtCSD, 0, sizeof(aExtCSD));
    r = FS_MMC_CM_ReadExtCSD(0, aExtCSD);
    if (r == 0) {
        pData8 = (U8 *)aExtCSD;
        SEGGER_sprintf(ac, sizeof(ac), "POWER_CLASS: %d\n", (int)pData8[187]);
        FS_X_Log(ac);
        SEGGER_sprintf(ac, sizeof(ac), "BUS_WIDTH: %d\n", (int)pData8[183]);
        FS_X_Log(ac);
        SEGGER_sprintf(ac, sizeof(ac), "HS_TIMING: %d\n", (int)pData8[185]);
        FS_X_Log(ac);
    }
}
```

6.5.3.2.8 FS_MMC_CM_ReadGeneral()

Description

Reads a block of data via General Command (CMD56).

Prototype

```
int FS_MMC_CM_ReadGeneral(U8    Unit,
                          U32    Arg,
                          U32 * pData);
```

Parameters

Parameter	Description
Unit	Index of the driver instance (0-based).
Arg	Command argument to be sent.
pData	out Read data.

Return value

= 0 OK, data successfully read.
 ≠ 0 An error has occurred.

Additional information

This function is optional. It can be used to read vendor-specific data from the storage device such as a health report. Additional information about the usage of CMD56 can be found in the data sheet of the storage device.

Not all the storage devices support CMD56. `FS_MMC_CM_ReadGeneral()` does not check if the command is actually supported by the storage device. Typically, the storage device reports an error if it does not support CMD56.

The value passed via [Arg](#) is vendor-specific and is sent as is to the storage device. The only exception is the bit 0 of [Arg](#) that indicates the direction of the data transfer and that is automatically set to 1 by this function.

[pData](#) has to be at least 512 bytes large.

6.5.3.2.9 FS_MMC_CM_ReadSectors()

Description

Reads blocks of data from the active partition of the storage card.

Prototype

```
int FS_MMC_CM_ReadSectors(U8    Unit,
                          U32    SectorIndex,
                          U32 * pData,
                          U32    NumSectors);
```

Parameters

Parameter	Description
Unit	Index of the driver instance (0-based).
SectorIndex	Index of the first data block to be read.
pData	out Read data.
NumSectors	Number of data blocks to be read.

Return value

= 0 OK, data read successfully.
 ≠ 0 An error occurred.

Additional information

The size of a single data block is 512 bytes.

In addition to reading data from the default partition of an eMMC device (User Data Area), this function can be used to read data from the Boot Area 1 and 2 partitions. The application is responsible for selecting the corresponding partition via the Extended CSD register as described in the eMMC specification. The Extended CSD register can be modified via `FS_MM-C_CM_WriteExtCSD()`.

An SD card has only one data partition.

Example

The following example reads the contents of the data blocks with the indexes 7 and 8 from the selected partition of the storage device.

```
#include "FS.h"

void SampleMMC_CMReadSectors(void) {
    U32 aData[1024 / 4];

    FS_MEMSET(aData, 0, sizeof(aData));
    FS_MMC_CM_ReadSectors(0, 7, aData, 2);
}
```

6.5.3.2.10 FS_MMC_CM_ResetStatCounters()

Description

Sets to 0 all statistical counters.

Prototype

```
void FS_MMC_CM_ResetStatCounters(U8 Unit);
```

Parameters

Parameter	Description
<code>Unit</code>	Index of the driver instance (0-based).

Additional information

This function is optional. The statistical counters are automatically set to 0 when the storage device is mounted. The application can use `FS_MMC_CM_ResetStatCounters()` at any time during the file system operation. The statistical counters can be queried via `FS_MM-C_CM_GetStatCounters()`.

The statistical counters are available only when the file system is compiled with `FS_DEBUG_LEVEL` greater than or equal to `FS_DEBUG_LEVEL_CHECK_ALL` or with `FS_MMC_ENABLE_STATS` set to 1.

6.5.3.2.11 FS_MMC_CM_UnlockCardForced()

Description

Unlocks an SD card.

Prototype

```
int FS_MMC_CM_UnlockCardForced(U8 Unit);
```

Parameters

Parameter	Description
Unit	Index of the driver instance (0-based).

Return value

- = 0 OK, the SD card has been erased.
- ≠ 0 An error has occurred.

Additional information

This function is optional. SD cards can be locked with a password in order to prevent inadvertent access to sensitive data. It is not possible to access the data on a locked SD card without knowing the locking password. The application can use `FS_MMC_CM_UnlockCardForced()` to make locked SD card accessible again. The unlocking operation erases all the data stored on the SD card including the lock password.

6.5.3.2.12 FS_MMC_CM_WriteExtCSD()

Description

Writes to the Extended CSD register of a MMC device.

Prototype

```
int FS_MMC_CM_WriteExtCSD(    U8        Unit,
                             unsigned   Off,
                             const U8   * pData,
                             unsigned   NumBytes);
```

Parameters

Parameter	Description
Unit	Index of the driver instance (0-based).
Off	Byte offset in the Extended CSD register.
pData	<input type="checkbox"/> Register contents.
NumBytes	Number of bytes in pData buffer.

Return value

= 0 Register contents returned
 ≠ 0 An error has occurred

Additional information

This function is optional. Only the byte range 0-191 of the Extended CSD register is modifiable. For more information about the contents of the Extended CSD register refer to the MMC specification. The contents of the Extended CSD register can be read via `FS_MMC_CM_ReadExtCSD()`.

Example

The following example shows how to select the Boot Area 1 of the connected eMMC device as the active partition.

```
#include "FS.h"

void SampleMMC_CMWriteExtCSD(void) {
    U8 Data;

    Data = 0x01;
    FS_MMC_CM_WriteExtCSD(0, 179, &Data, sizeof(Data));
}
```

6.5.3.2.13 FS_MMC_CM_WriteGeneral()

Description

Writes a block of data via General Command (CMD56).

Prototype

```
int FS_MMC_CM_WriteGeneral(    U8    Unit,
                              U32    Arg,
                              const U32 * pData);
```

Parameters

Parameter	Description
<code>Unit</code>	Index of the driver instance (0-based).
<code>Arg</code>	Command argument to be sent.
<code>pData</code>	in Data to be written.

Return value

= 0 OK, data successfully written.
 ≠ 0 An error has occurred.

Additional information

This function is optional. It can be used to write vendor-specific data to a storage device such as the programming of a product string. Additional information about the usage of CMD56 can be found in the data sheet of the storage device.

Not all the storage devices support CMD56. `FS_MMC_CM_WriteGeneral()` does not check if the command is actually supported by the storage device. Typically, the storage device reports an error if it does not support CMD56.

The value passed via `Arg` is vendor-specific and is sent as is to the storage device. The only exception is the bit 0 of `Arg` that indicates the direction of the data transfer and that is automatically set to 0 by this function.

`pData` has to be at least 512 bytes large.

6.5.3.2.14 FS_MMC_CM_WriteSectors()

Description

Writes blocks of data to the selected partition of the storage card.

Prototype

```
int FS_MMC_CM_WriteSectors(    U8    Unit,
                               U32    SectorIndex,
                               const U32 * pData,
                               U32    NumSectors);
```

Parameters

Parameter	Description
Unit	Index of the driver instance (0-based).
SectorIndex	Index of the first data block to be written.
pData	in Data to be written.
NumSectors	Number of data blocks to be written.

Return value

= 0 OK, data written successfully.
 ≠ 0 An error occurred.

Additional information

The size of a single data block is 512 bytes.

In addition to writing data to the default partition of an eMMC device (User Data Area), this function can be used to write data to the Boot Area 1 and 2 partitions. The application is responsible for selecting the corresponding partition via the Extended CSD register as described in the eMMC specification. The Extended CSD register can be modified via `FS_MM-C_CM_WriteExtCSD()`.

An SD card has only one data partition.

Example

The following example writes the contents of the data blocks with the indexes 5 and 6 to the selected partition of the storage device.

```
#include "FS.h"

void SampleMMC_CMWriteSectors(void) {
    U32 aData[1024 / 4];

    FS_MEMSET(aData, 0x55, sizeof(aData));
    FS_MMC_CM_WriteSectors(0, 5, aData, 2);
}
```

6.5.3.2.15 FS_MMC_CARD_ID

Description

Information about the storage card.

Type definition

```
typedef struct {  
    U8  aData[];  
} FS_MMC_CARD_ID;
```

Structure members

Member	Description
<code>aData</code>	Identification information as returned by the SD card or MMC device as response to CMD10 command.

Additional information

The card identification can be read via `FS_MMC_GetCardId()` or `FS_MMC_CM_GetCardId()`

6.5.3.2.16 FS_MMC_CARD_INFO

Description

Information about the storage device.

Type definition

```
typedef struct {
    U8   CardType;
    U8   BusWidth;
    U8   IsWriteProtected;
    U8   IsHighSpeedMode;
    U16  BytesPerSector;
    U32  NumSectors;
    U32  ClockFreq;
    U16  VoltageLevel;
    U8   AccessMode;
    U8   DriverStrength;
} FS_MMC_CARD_INFO;
```

Structure members

Member	Description
CardType	Type of the storage card.
BusWidth	Number of data lines used for the data transfer.
IsWriteProtected	Set to 1 if the card is write protected.
IsHighSpeedMode	Set to 1 if the card operates in the high-speed mode.
BytesPerSector	Number of bytes in a sector.
NumSectors	Total number of sectors on the card.
ClockFreq	Frequency of the clock supplied to storage device in Hz.
VoltageLevel	Voltage level of I/O lines.
AccessMode	Type of data transfer.
DriverStrength	Actual output driving strength of the MMC/SD device.

Additional information

For a list of permitted values for [CardType](#) refer to *Storage card types* on page 1027. [BusWidth](#) can take one of these values: 1, 4 or 8. [BytesPerSector](#) is typically 512 bytes. For a list of permitted values for [AccessMode](#) refer to *Data transfer types* on page 1026. [IsHighSpeedMode](#) is deprecated and [AccessMode](#) can be used instead. [IsHighSpeedMode](#) set to 1 is equivalent to [AccessMode](#) set to `FS_MMC_ACCESS_MODE_HS`.

6.5.3.2.17 FS_MMC_STAT_COUNTERS

Description

Statistical counters maintained by the MMC/SD driver

Type definition

```
typedef struct {  
    U32 WriteSectorCnt;  
    U32 WriteErrorCnt;  
    U32 ReadSectorCnt;  
    U32 ReadErrorCnt;  
    U32 CmdExecCnt;  
} FS_MMC_STAT_COUNTERS;
```

Structure members

Member	Description
WriteSectorCnt	Number of logical sectors read.
WriteErrorCnt	Number of write errors.
ReadSectorCnt	Number of logical sectors written.
ReadErrorCnt	Number of read errors.
CmdExecCnt	Number of commands executed.

6.5.3.2.18 Data transfer types

Description

Types of exchanging data with an MMC/SD storage device.

Definition

```
#define FS_MMC_ACCESS_MODE_UNKNOWN 0u
#define FS_MMC_ACCESS_MODE_DS      1u
#define FS_MMC_ACCESS_MODE_HS      2u
#define FS_MMC_ACCESS_MODE_SDR50   3u
#define FS_MMC_ACCESS_MODE_DDR50    4u
#define FS_MMC_ACCESS_MODE_SDR104  5u
#define FS_MMC_ACCESS_MODE_HS_DDR   6u
#define FS_MMC_ACCESS_MODE_HS200    7u
#define FS_MMC_ACCESS_MODE_HS400    8u
```

Symbols

Definition	Description
FS_MMC_ACCESS_MODE_UNKNOWN	Invalid access mode
FS_MMC_ACCESS_MODE_DS	Clock frequency up to 25 MHz for SD cards and 26 MHz for MMC devices (Default speed).
FS_MMC_ACCESS_MODE_HS	Clock frequency up to 50 MHz for SD cards and 52 MHz for MMC devices (High speed).
FS_MMC_ACCESS_MODE_SDR50	Clock frequency up to 100 MHz with 1.8 V signaling. For SD cards only.
FS_MMC_ACCESS_MODE_DDR50	Clock frequency up to 50 MHz with 1.8 V signaling and data exchanged on both clock edges. For SD cards only.
FS_MMC_ACCESS_MODE_SDR104	Clock frequency up to 208 MHz with 1.8 V signaling. For SD cards only.
FS_MMC_ACCESS_MODE_HS_DDR	Clock frequency up to 52 MHz with 1.8 V and 3.3V signaling and data exchanged on both clock edges. For MMC devices only.
FS_MMC_ACCESS_MODE_HS200	Clock frequency up to 200 MHz with 1.8 V signaling. For MMC devices only.
FS_MMC_ACCESS_MODE_HS400	Clock frequency up to 200 MHz with 1.8 V signaling and data exchanged on both clock edges. For MMC devices only.

6.5.3.2.19 Storage card types

Description

Type of storage devices supported by the MMC/SD driver.

Definition

```
#define FS_MMC_CARD_TYPE_UNKNOWN    0
#define FS_MMC_CARD_TYPE_MMC       1
#define FS_MMC_CARD_TYPE_SD        2
```

Symbols

Definition	Description
FS_MMC_CARD_TYPE_UNKNOWN	The driver was not able to identify the device.
FS_MMC_CARD_TYPE_MMC	The storage device conforms to MMC specification.
FS_MMC_CARD_TYPE_SD	The storage device conforms to SD specification.

6.5.3.3 Performance and resource usage

6.5.3.3.1 ROM usage

The ROM usage depends on the compiler options, the compiler version and the used CPU. The memory requirements of the Card Mode MMC/SD driver were measured as described in the section *Test procedure* on page 1283.

Usage: 3.9 Kbytes

6.5.3.3.2 Static RAM usage

Static RAM usage refers to the amount of RAM required by the Card Mode MMC/SD driver internally for all the driver instances. The number of bytes can be seen in the compiler list file of the `FS_MMC_CM_Drv.c` file.

Usage: 12 bytes

6.5.3.3.3 Dynamic RAM usage

Dynamic RAM usage is the amount of RAM allocated by the driver at runtime. The amount of RAM required depends on the compile time and runtime configuration.

Usage: 42 bytes

6.5.3.3.4 Performance

These performance measurements are in no way complete, but they give an approximation of the length of time required for common operations on various targets. The tests were performed as described in the section *Performance* on page 1289. All values are given in Mbytes/second.

CPU type	MMC/SD device	Write speed	Read speed
Atmel AT91SAM9263 (200 MHz)	Ultron 256MB SD card	10.0	9.3
NXP LPC2478 (57 MHz)	Ultron 256MB SD card	2.4	3.1
NXP LPC3250 (208 MHz)	Ultron 256MB SD card	3.9	8.4
NXP K66 (168 MHz)	SanDisk 16GB Ultra PLUS SD card	3.6	11.1
Microchip SAME70 (300 MHz)	SanDisk 16GB Ultra PLUS SD card	11.1	20.4
NXP iMX6U5	SanDisk 16GB Ultra PLUS SD card	15.1	18.4
NXP iMXRT1052	SanDisk 16GB Ultra PLUS SD card	16.9	19.5
NPX LPC54608	SanDisk 16GB Ultra PLUS SD card	11.6	18.4
Renesas RZGE1	Silicon Motion SM661G8 eMMC	5.5	16.5
ST STM32H743	SanDisk 16GB Ultra PLUS SD card	10.0	14.4
ST STM32F746	Transcend 16GB Class 10 SD card	12.2	18.9
ST STM32F469	SanDisk 16GB Ultra PLUS SD card	16.1	17.8
ST STM32H753 (400 MHz)	SanDisk 32GB Ultra SD card	13.7	49.8
NXP iMXRT595	SanDisk SDINBDA6-16 eMMC device	102.4	136.5

6.5.4 MMC/SD hardware layer

The hardware layer provides the functions required to the MMC/SD driver to access the target hardware via SPI controller, SD host controller, GPIO, etc. The functions of the MMC/SD hardware layer are called by the MMC/SD driver to exchange commands and data with an MMC or SD card. Since these functions are hardware dependent, they have to be implemented by the user. emFile comes with template hardware layers and sample implementations for popular evaluation boards that can be used as starting point for the implementation of new hardware layers. The relevant files are located in the `/Sample/FS/Driver/MMC_SPI` and `/Sample/FS/Driver/MMC_CM` folders of the emFile shipment.

6.5.4.1 Hardware layer types

The functions of the MMC/SD hardware layer are organized in a function table implemented a C structure. Different hardware layer types are provided to support different ways of interfacing an MMC or SD card. The type of hardware layer an application has to use depends on the MMC/SD driver used. The following table lists what hardware layer is required by each MMC/SD driver.

MMC/SD hardware layer	MMC/SD driver
FS_MMC_HW_TYPE_SPI	<i>SPI MMC/SD driver</i>
FS_MMC_HW_TYPE_CM	<i>Card Mode MMC/SD driver</i>

6.5.4.2 Hardware layer API - `FS_MMC_HW_TYPE_SPI`

This hardware layer supports MMC cards that comply with the version 3.x or older of the MMC specification and SD cards of all types that are interfaced to the target MCU via SPI. The functions of this hardware layer are grouped in a structure of type `FS_MMC_HW_TYPE_SPI`. The following sections describe these functions in detail.

6.5.4.2.1 FS_MMC_HW_TYPE_SPI

Description

Hardware layer for the SPI MMC/SD driver.

Type definition

```
typedef struct {
    FS_MMC_HW_TYPE_SPI_ENABLE_CS          * pfEnableCS;
    FS_MMC_HW_TYPE_SPI_DISABLE_CS        * pfDisableCS;
    FS_MMC_HW_TYPE_SPI_IS_PRESENT        * pfIsPresent;
    FS_MMC_HW_TYPE_SPI_IS_WRITE_PROTECTED * pfIsWriteProtected;
    FS_MMC_HW_TYPE_SPI_SET_MAX_SPEED     * pfSetMaxSpeed;
    FS_MMC_HW_TYPE_SPI_SET_VOLTAGE       * pfSetVoltage;
    FS_MMC_HW_TYPE_SPI_READ              * pfRead;
    FS_MMC_HW_TYPE_SPI_WRITE             * pfWrite;
    FS_MMC_HW_TYPE_SPI_READ_EX           * pfReadEx;
    FS_MMC_HW_TYPE_SPI_WRITE_EX          * pfWriteEx;
    FS_MMC_HW_TYPE_SPI_LOCK              * pfLock;
    FS_MMC_HW_TYPE_SPI_UNLOCK            * pfUnlock;
} FS_MMC_HW_TYPE_SPI;
```

Structure members

Member	Description
pfEnableCS	Enables the card.
pfDisableCS	Disables the card.
pfIsPresent	Checks if the card is inserted.
pfIsWriteProtected	Checks if the card is write protected.
pfSetMaxSpeed	Configures the clock frequency supplied to the card.
pfSetVoltage	Configures the voltage level of the card power supply.
pfRead	Transfers data from card to MCU.
pfWrite	Transfers data from MCU to card.
pfReadEx	Transfers data from card to MCU.
pfWriteEx	Transfers data from MCU to card.
pfLock	Requires exclusive access to SPI bus.
pfUnlock	Releases exclusive access to SPI bus.

6.5.4.2.2 FS_MMC_HW_TYPE_SPI_ENABLE_CS

Description

Enables the storage card.

Type definition

```
typedef void FS_MMC_HW_TYPE_SPI_ENABLE_CS(U8 Unit);
```

Parameters

Parameter	Description
Unit	Index of the hardware layer instance (0-based)

Additional information

This function is a member of the SPI MMC/SD hardware layer. It has to be implemented by all the hardware layers.

The Chip Select (CS) signal is used to address a specific MMC or SD card connected via SPI. Enabling the card is equal to setting the CS signal to a logic low level.

6.5.4.2.3 FS_MMC_HW_TYPE_SPI_DISABLE_CS

Description

Disables the storage card.

Type definition

```
typedef void FS_MMC_HW_TYPE_SPI_DISABLE_CS(U8 Unit);
```

Parameters

Parameter	Description
Unit	Index of the hardware layer instance (0-based)

Additional information

This function is a member of the SPI MMC/SD hardware layer. It has to be implemented by all the hardware layers.

The Chip Select (CS) signal is used to address a specific MMC or SD card connected via SPI. Disabling the card is equal to setting the CS signal to a logic high level.

6.5.4.2.4 FS_MMC_HW_TYPE_SPI_IS_PRESENT

Description

Checks if the storage card is present.

Type definition

```
typedef int FS_MMC_HW_TYPE_SPI_IS_PRESENT(U8 Unit);
```

Parameters

Parameter	Description
Unit	Index of the hardware layer instance (0-based)

Return value

FS_MEDIA_STATE_UNKNOWN	The presence state of the card is unknown.
FS_MEDIA_NOT_PRESENT	The card is present.
FS_MEDIA_IS_PRESENT	The card is not present.

Additional information

This function is a member of the SPI MMC/SD hardware layer. It has to be implemented by all the hardware layers.

Typically, the card presence detection is implemented via a dedicated Card Detect (CD) signal. This signal is connected to a switch inside the card slot that changes its state each time the card is removed or inserted. If the hardware does not provide such signal the function has to return `FS_MEDIA_STATE_UNKNOWN`.

6.5.4.2.5 FS_MMC_HW_TYPE_SPI_IS_WRITE_PROTECTED

Description

Checks if the storage card is write protected.

Type definition

```
typedef int FS_MMC_HW_TYPE_SPI_IS_WRITE_PROTECTED(U8 Unit);
```

Parameters

Parameter	Description
Unit	Index of the hardware layer instance (0-based)

Return value

- = 0 The card data can be modified.
- ≠ 0 The card data cannot be modified.

Additional information

This function is a member of the SPI MMC/SD hardware layer. It has to be implemented by all the hardware layers.

Typically, the card protection status is implemented via a dedicated Write Protected (WP) signal. This signal is connected to a switch inside the card slot that reflects the status of the write protect switch found on SD cards. If the hardware does not provide such signal the function has to return 0.

MMC and micro SD cards do not have a write protection switch. Please note that the write protect switch does not really protect the data on an SD card from being modified. It is merely an indication that the data has to be protected. It is the responsibility of the host MCU to respect the status of this switch.

6.5.4.2.6 FS_MMC_HW_TYPE_SPI_SET_MAX_SPEED

Description

Configures the clock frequency supplied to the storage card.

Type definition

```
typedef U16 FS_MMC_HW_TYPE_SPI_SET_MAX_SPEED(U8 Unit,
                                              U16 MaxFreq);
```

Parameters

Parameter	Description
<code>Unit</code>	Index of the hardware layer instance (0-based)
<code>MaxFreq</code>	Maximum allowed frequency of the SPI clock in kHz.

Return value

≠ 0 The actual clock frequency in kHz.
 = 0 An error occurred.

Additional information

This function is a member of the SPI MMC/SD hardware layer. It has to be implemented by all the hardware layers.

The hardware layer is allowed to set a clock frequency smaller than the value specified via `MaxFreq` but never greater than that. The SPI MMC/SD driver calls this function at least two times during the initialization of the MMC or SD card:

- Before the initialization starts to set the clock frequency to 400 kHz.
- After the card identification to set the standard clock frequency which is 25 MHz for SD cards or 20 MHz for MMC cards.

The function has to return the actual configured clock frequency. If the precise frequency is unknown such as for implementation using I/O port "bit-banging", the return value has to be less than the specified frequency. This may lead to longer timeout values but is in general does not cause any problems. The SPI MMC/SD driver uses the returned value to calculate timeout values.

6.5.4.2.7 FS_MMC_HW_TYPE_SPI_SET_VOLTAGE

Description

Configures the voltage level of the storage card power supply.

Type definition

```
typedef int FS_MMC_HW_TYPE_SPI_SET_VOLTAGE(U8 Unit,
                                             U16 VMin,
                                             U16 VMax);
```

Parameters

Parameter	Description
<code>Unit</code>	Index of the hardware layer instance (0-based)
<code>VMin</code>	Minimum supply voltage level in mV.
<code>VMax</code>	Maximum supply voltage level in mV.

Return value

- 1 Card slot supports the voltage range.
- 0 Card slot does not support the voltage range.

Additional information

This function is a member of the SPI MMC/SD hardware layer. It has to be implemented by all the hardware layers.

By default, all cards work with the initial voltage of 3.3V. If hardware layer has to save power, then the supply voltage can be adjusted within the specified range.

6.5.4.2.8 FS_MMC_HW_TYPE_SPI_READ

Description

Transfers data from storage card to MCU.

Type definition

```
typedef void FS_MMC_HW_TYPE_SPI_READ(U8 Unit,
                                     U8 * pData,
                                     int NumBytes);
```

Parameters

Parameter	Description
Unit	Index of the hardware layer instance (0-based)
pData	out Data transferred from card.
NumBytes	Number of bytes to be transferred.

Additional information

This function is a member of the SPI MMC/SD hardware layer. FS_MMC_HW_TYPE_SPI_READ does not have to be implemented if the hardware layer provides an implementation for FS_MMC_HW_TYPE_SPI_READ_EX.

The data is received via the DIN (MISO) signal of the SPI interface with the data being sampled on the rising edge of the clock signal. According to the SD specification the DOUT (MOSI) signal must be driven to logic high during the data transfer, otherwise the SD card will not work properly.

The SPI MMC/SD driver calls this function only when the card is enabled that is with the CS signal at logic low level.

The following picture shows the waveforms of the SPI signals during the transfer of 8 bits from card to MCU.

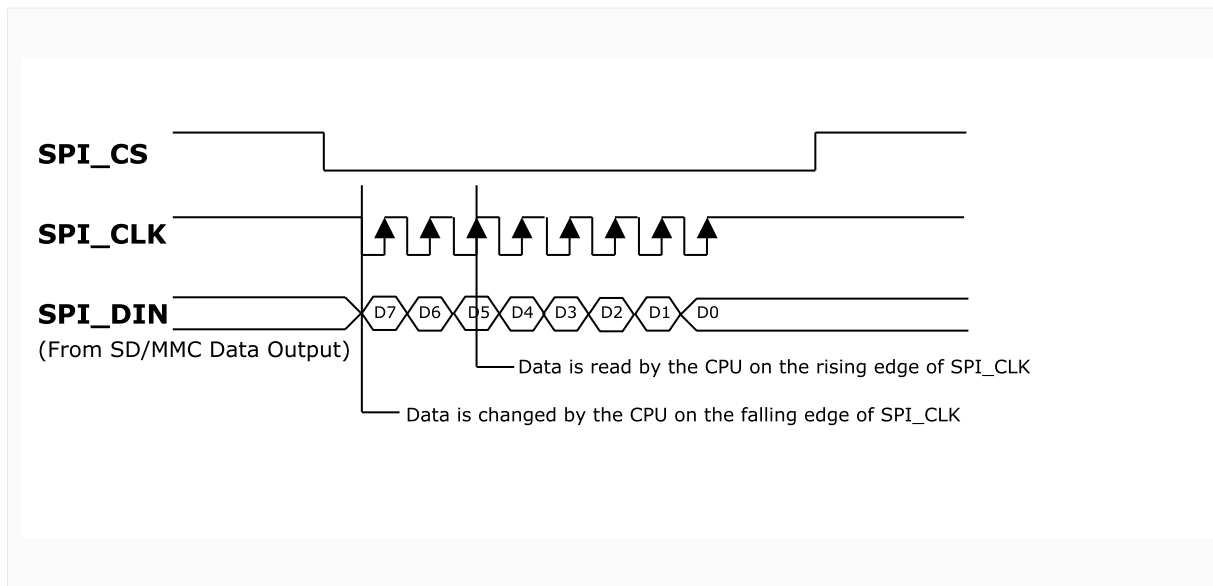

Read access

6.5.4.2.9 FS_MMC_HW_TYPE_SPI_WRITE

Description

Transfers data from MCU to card.

Type definition

```
typedef void FS_MMC_HW_TYPE_SPI_WRITE(
    U8 Unit,
    const U8 * pData,
    int NumBytes);
```

Parameters

Parameter	Description
Unit	Index of the hardware layer instance (0-based)
pData	in Data to be transferred to card.
NumBytes	Number of bytes to be transferred to card.

Additional information

This function is a member of the SPI MMC/SD hardware layer. FS_MMC_HW_TYPE_SPI_WRITE does not have to be implemented if the hardware layer provides an implementation for FS_MMC_HW_TYPE_SPI_WRITE_EX.

The data is sent via the DOUT (MOSI) signal of the SPI interface with the data being changed on the falling edge of the clock signal.

The SPI MMC/SD driver also calls this function when the card is not enabled that is with the CS signal at logic low in order to generate empty cycles.

The following picture shows the waveforms of the SPI signals during the transfer of 8 bits from MCU to card.

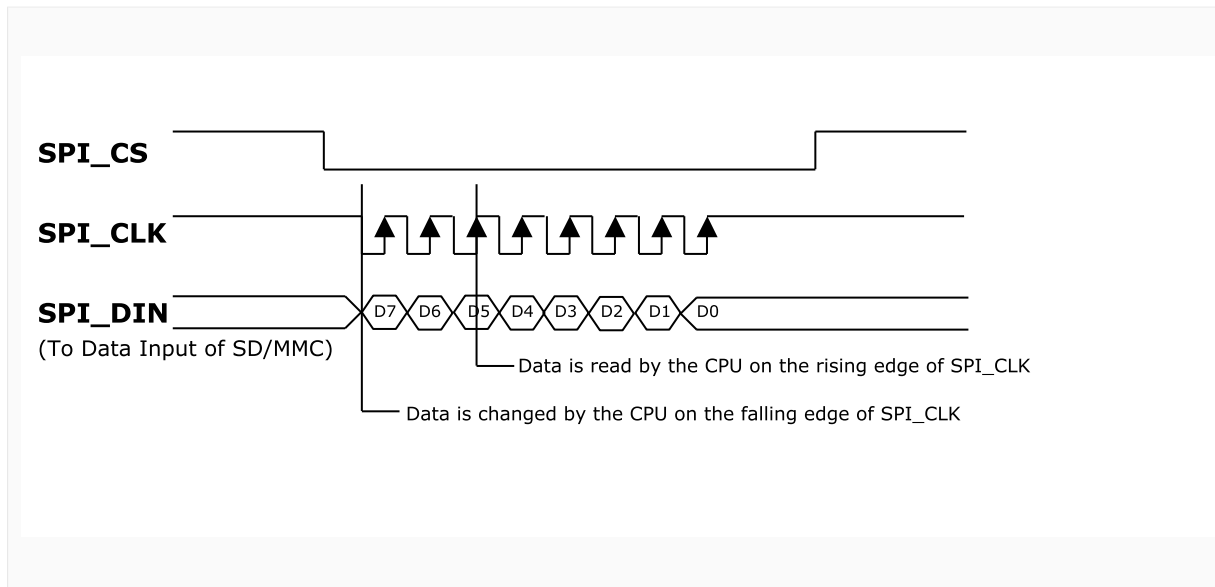

Write access

6.5.4.2.10 FS_MMC_HW_TYPE_SPI_READ_EX

Description

Transfers data from card to MCU.

Type definition

```
typedef int FS_MMC_HW_TYPE_SPI_READ_EX(U8    Unit,
                                       U8 * pData,
                                       int   NumBytes);
```

Parameters

Parameter	Description
<code>Unit</code>	Index of the hardware layer instance (0-based)
<code>pData</code>	out Data transferred from card.
<code>NumBytes</code>	Number of bytes to be transferred.

Return value

= 0 OK, data transferred.
 ≠ 0 An error occurred.

Additional information

This function is a member of the SPI MMC/SD hardware layer. `FS_MMC_HW_TYPE_SPI_READ_EX` does not have to be implemented if the hardware layer provides an implementation for `FS_MMC_HW_TYPE_SPI_READ`. It provides the same functionality as `FS_MMC_HW_TYPE_SPI_READ` with the difference that it can report the result of the operation to the SPI MMC/SD driver.

The SPI MMC/SD driver calls this function only when the card is enabled that is with the CS signal at logic low level.

6.5.4.2.11 FS_MMC_HW_TYPE_SPI_WRITE_EX

Description

Transfers data from MCU to storage card.

Type definition

```
typedef int FS_MMC_HW_TYPE_SPI_WRITE_EX(      U8    Unit,
                                              const U8 * pData,
                                              int   NumBytes);
```

Parameters

Parameter	Description
<code>Unit</code>	Index of the hardware layer instance (0-based)
<code>pData</code>	in Data to be transferred to card.
<code>NumBytes</code>	Number of bytes to be transferred to card.

Return value

= 0 OK, data transferred.
 ≠ 0 An error occurred.

Additional information

This function is a member of the SPI MMC/SD hardware layer. `FS_MMC_HW_TYPE_SPI_WRITE_EX` does not have to be implemented if the hardware layer provides an implementation for `FS_MMC_HW_TYPE_SPI_WRITE`. It provides the same functionality as `FS_MMC_HW_TYPE_SPI_WRITE` with the difference that it can report the result of the operation to the SPI MMC/SD driver.

The SPI MMC/SD driver also calls this function when the card is not enabled that is with the CS signal at logic low in order to generate empty cycles.

6.5.4.2.12 FS_MMC_HW_TYPE_SPI_LOCK

Description

Requires exclusive access to SPI bus.

Type definition

```
typedef void FS_MMC_HW_TYPE_SPI_LOCK(U8 Unit);
```

Parameters

Parameter	Description
<code>Unit</code>	Index of the hardware layer instance (0-based)

Additional information

This function is a member of the SPI MMC/SD hardware layer. The implementation of this function is optional.

The SPI MMC/SD driver calls this function to indicate that it needs exclusive to access the card via the SPI bus. It is guaranteed that the SPI MMC/SD driver does not attempt to exchange any data with the card via the SPI bus before calling this function first. It is also guaranteed that `FS_MMC_HW_TYPE_SPI_LOCK` and `FS_MMC_HW_TYPE_SPI_UNLOCK` are called in pairs. Typically, this function is used for synchronizing the access to SPI bus when the SPI bus is shared between the card and other SPI devices.

A possible implementation would make use of an OS semaphore that is acquired in `FS_MMC_HW_TYPE_SPI_LOCK` and released in `FS_MMC_HW_TYPE_SPI_UNLOCK`.

`FS_MMC_HW_TYPE_SPI_LOCK` is called only when the SPI MMC/SD driver is compiled with `FS_MMC_SUPPORT_LOCKING` set to 1.

6.5.4.2.13 FS_MMC_HW_TYPE_SPI_UNLOCK

Description

Releases the exclusive access to SPI bus.

Type definition

```
typedef void FS_MMC_HW_TYPE_SPI_UNLOCK(U8 Unit);
```

Parameters

Parameter	Description
<code>Unit</code>	Index of the hardware layer instance (0-based)

Additional information

This function is a member of the SPI MMC/SD hardware layer. The implementation of this function is optional.

The SPI MMC/SD driver calls this function when it no longer needs to access the card via the SPI bus. It is guaranteed that the SPI MMC/SD driver does not attempt to exchange any data with the card via the SPI bus before calling `FS_MMC_HW_TYPE_SPI_LOCK`. It is also guaranteed that `FS_MMC_HW_TYPE_SPI_UNLOCK` and `FS_MMC_HW_TYPE_SPI_LOCK` are called in pairs.

`FS_MMC_HW_TYPE_SPI_UNLOCK` and `FS_MMC_HW_TYPE_SPI_LOCK` can be used to synchronize the access to the SPI bus when other devices than the serial NAND flash are connected to it. A possible implementation would make use of an OS semaphore that is acquired `FS_MMC_HW_TYPE_SPI_LOCK` and released in `FS_MMC_HW_TYPE_SPI_UNLOCK`.

`FS_MMC_HW_TYPE_SPI_LOCK` is called only when the SPI MMC/SD driver is compiled with `FS_MMC_SUPPORT_LOCKING` set to 1.

6.5.4.2.14 Sample implementation

The following sample implementation uses the SPI controller of an TI TM4C129 MCU to interface with an SD card. This hardware layer was tested on the TI TIVAC129 evaluation board.

```

/*****
*                               (c) SEGGER Microcontroller GmbH                               *
*                               The Embedded Experts                                       *
*                               www.segger.com                                           *
*****
----- END-OF-HEADER -----

File       : FS_MMC_HW_SPI_TM4C129_TI_TIVAC129.c
Purpose    : Generic HW layer for the MMC / SD driver working in SPI mode.
Literature :
  [1] Tiva TM4C129XNCZAD Microcontroller DATA SHEET
  [2] Tiva TM4C129X Development Board User's Guide

Additional information
  The SD card and NOR flash device share the same CS signal. In order to
  be able to work with the SD card, the jumper J7 has to be configured
  according to "2.1.10 EEPROM and SD Card" in [2].
*/

/*****
*
*   #include Section
*
*****
*/
#include "FS.h"

/*****
*
*   Defines, configurable
*
*****
*/
#ifndef FS_MMC_HW_SPI_PERIPH_CLOCK_KHZ
#define FS_MMC_HW_SPI_PERIPH_CLOCK_KHZ      120000uL
// Clock of SSI peripheral in kHz
#endif

#ifndef FS_MMC_HW_SPI_MAX_SPI_CLOCK_KHZ
#define FS_MMC_HW_SPI_MAX_SPI_CLOCK_KHZ    24000uL
// Maximum clock frequency supplied to SD card
#endif

#ifndef FS_MMC_HW_SPI_WAIT_TIMEOUT_CYCLES
#define FS_MMC_HW_SPI_WAIT_TIMEOUT_CYCLES  100000uL
// Time to wait for an operation to finish (software loops)
#endif

#ifndef FS_MMC_HW_SPI_USE_DMA
#define FS_MMC_HW_SPI_USE_DMA              1
// Enables/disables the data transfer via DMA
#endif

#ifndef FS_MMC_HW_SPI_DEFAULT_SUPPLY_VOLTAGE
#define FS_MMC_HW_SPI_DEFAULT_SUPPLY_VOLTAGE 3300 // in mV, example means 3.3V
#endif

/*****
*
*   Defines, fixed
*
*****
*/

/*****
*
*   SSI registers
*/

```

```

#define SSI_BASE_ADDR          0x400B000uL
#define SSICR0                 (*(volatile U32 *) (SSI_BASE_ADDR + 0x000))
    // SSI Control 0
#define SSICR1                 (*(volatile U32 *) (SSI_BASE_ADDR + 0x004))
    // SSI Control 1
#define SSIDR                  (*(volatile U32 *) (SSI_BASE_ADDR + 0x008))
    // SSI Data
#define SSISR                  (*(volatile U32 *) (SSI_BASE_ADDR + 0x00C))
    // SSI Status
#define SSICPSR                (*(volatile U32 *) (SSI_BASE_ADDR + 0x010))
    // SSI Clock Prescale
#define SSIIM                  (*(volatile U32 *) (SSI_BASE_ADDR + 0x014))
    // SSI Interrupt Mask
#define SSIRIS                 (*(volatile U32 *) (SSI_BASE_ADDR + 0x018))
    // SSI Raw Interrupt Status
#define SSIMIS                 (*(volatile U32 *) (SSI_BASE_ADDR + 0x01C))
    // SSI Masked Interrupt Status
#define SSIICR                 (*(volatile U32 *) (SSI_BASE_ADDR + 0x020))
    // SSI Interrupt Clear
#define SSIDMACTL              (*(volatile U32 *) (SSI_BASE_ADDR + 0x024))
    // SSI DMA Control
#define SSICC                  (*(volatile U32 *) (SSI_BASE_ADDR + 0xFC8))
    // SSI Clock Configuration

/*****
 *
 *      System control registers
 */
#define SYS_BASE_ADDR          0x400FE000uL
#define RCGCGPIO               (*(volatile U32 *) (SYS_BASE_ADDR + 0x608))
    // GPIO Run Mode Clock Gating Control
#define RCGCDMA                (*(volatile U32 *) (SYS_BASE_ADDR + 0x60C))
    // DMA Run Mode Clock Gating Control
#define RCGCSSI                (*(volatile U32 *) (SYS_BASE_ADDR + 0x61C))
    // SSI Run Mode Clock Gating Control
#define PRGPIO                 (*(volatile U32 *) (SYS_BASE_ADDR + 0xA08))
    // GPIO Run Mode Peripheral Ready
#define PRDMA                  (*(volatile U32 *) (SYS_BASE_ADDR + 0xA0C))
    // DMA Run Mode Peripheral Ready
#define PRSSI                  (*(volatile U32 *) (SYS_BASE_ADDR + 0xA1C))
    // SSI Run Mode Peripheral Ready

/*****
 *
 *      GPIO Port F
 */
#define PF_BASE_ADDR           0x4005D000uL
#define PF_GPIOAFSEL           (*(volatile U32 *) (PF_BASE_ADDR + 0x420))
    // GPIO Alternate Function Select
#define PF_GPIODR2R            (*(volatile U32 *) (PF_BASE_ADDR + 0x500))    // GPIO
    2-mA Drive Select
#define PF_GPIODR4R            (*(volatile U32 *) (PF_BASE_ADDR + 0x504))    // GPIO
    4-mA Drive Select
#define PF_GPIODR8R            (*(volatile U32 *) (PF_BASE_ADDR + 0x508))    // GPIO
    8-mA Drive Select
#define PF_GPIODR              (*(volatile U32 *) (PF_BASE_ADDR + 0x50C))
    // GPIO Open Drain Select
#define PF_GPIOPUR             (*(volatile U32 *) (PF_BASE_ADDR + 0x510))
    // GPIO Pull-Up Select
#define PF_GPIOPDR             (*(volatile U32 *) (PF_BASE_ADDR + 0x514))
    // GPIO Pull-Down Select
#define PF_GPIODEN             (*(volatile U32 *) (PF_BASE_ADDR + 0x51C))
    // GPIO Digital Enable
#define PF_GPIOPCTL            (*(volatile U32 *) (PF_BASE_ADDR + 0x52C))
    // GPIO Port Control
#define PF_GPIOPC              (*(volatile U32 *) (PF_BASE_ADDR + 0xFC4))
    // GPIO Peripheral Configuration

/*****
 *
 *      GPIO Port H
 */
#define PH_BASE_ADDR           0x4005F000uL
#define PH_GPIODATA            (*(volatile U32 *) (PH_BASE_ADDR + 0x000))
    // GPIO Data

```

```

#define PH_GPIODIR                (*(volatile U32 *) (PH_BASE_ADDR + 0x400))
    // GPIO Direction
#define PH_GPIOAFSEL              (*(volatile U32 *) (PH_BASE_ADDR + 0x420))
    // GPIO Alternate Function Select
#define PH_GPIODR2R               (*(volatile U32 *) (PH_BASE_ADDR + 0x500))    // GPIO
    2-mA Drive Select
#define PH_GPIODR4R               (*(volatile U32 *) (PH_BASE_ADDR + 0x504))    // GPIO
    4-mA Drive Select
#define PH_GPIODR8R               (*(volatile U32 *) (PH_BASE_ADDR + 0x508))    // GPIO
    8-mA Drive Select
#define PH_GPIOODR                (*(volatile U32 *) (PH_BASE_ADDR + 0x50C))
    // GPIO Open Drain Select
#define PH_GPIOPUR                (*(volatile U32 *) (PH_BASE_ADDR + 0x510))
    // GPIO Pull-Up Select
#define PH_GPIOPCR                (*(volatile U32 *) (PH_BASE_ADDR + 0x514))
    // GPIO Pull-Down Select
#define PH_GPIODEN                (*(volatile U32 *) (PH_BASE_ADDR + 0x51C))
    // GPIO Digital Enable
#define PH_GPIOPCR                (*(volatile U32 *) (PH_BASE_ADDR + 0x52C))
    // GPIO Port Control
#define PH_GPIOPC                 (*(volatile U32 *) (PH_BASE_ADDR + 0xFC4))
    // GPIO Peripheral Configuration

/*****
*
*       GPIO Port Q
*/
#define PQ_BASE_ADDR              0x40066000uL
#define PQ_GPIODATA              (*(volatile U32 *) (PQ_BASE_ADDR + 0x000))
    // GPIO Data
#define PQ_GPIODIR                (*(volatile U32 *) (PQ_BASE_ADDR + 0x400))
    // GPIO Direction
#define PQ_GPIOAFSEL              (*(volatile U32 *) (PQ_BASE_ADDR + 0x420))
    // GPIO Alternate Function Select
#define PQ_GPIODR2R               (*(volatile U32 *) (PQ_BASE_ADDR + 0x500))    // GPIO
    2-mA Drive Select
#define PQ_GPIODR4R               (*(volatile U32 *) (PQ_BASE_ADDR + 0x504))    // GPIO
    4-mA Drive Select
#define PQ_GPIODR8R               (*(volatile U32 *) (PQ_BASE_ADDR + 0x508))    // GPIO
    8-mA Drive Select
#define PQ_GPIOODR                (*(volatile U32 *) (PQ_BASE_ADDR + 0x50C))
    // GPIO Open Drain Select
#define PQ_GPIOPUR                (*(volatile U32 *) (PQ_BASE_ADDR + 0x510))
    // GPIO Pull-Up Select
#define PQ_GPIOPCR                (*(volatile U32 *) (PQ_BASE_ADDR + 0x514))
    // GPIO Pull-Down Select
#define PQ_GPIODEN                (*(volatile U32 *) (PQ_BASE_ADDR + 0x51C))
    // GPIO Digital Enable
#define PQ_GPIOPCR                (*(volatile U32 *) (PQ_BASE_ADDR + 0x52C))
    // GPIO Port Control
#define PQ_GPIOPC                 (*(volatile U32 *) (PQ_BASE_ADDR + 0xFC4))
    // GPIO Peripheral Configuration

/*****
*
*       DMA controller
*/
#define DMA_BASE_ADDR             0x400FF000uL
#define DMACFG                    (*(volatile U32 *) (DMA_BASE_ADDR + 0x004))
    // DMA configuration
#define DMACTLBASE                (*(volatile U32 *) (DMA_BASE_ADDR + 0x008))
    // DMA Channel Control Base Pointer
#define DMAUSEBURSTCLR            (*(volatile U32 *) (DMA_BASE_ADDR + 0x01C))
    // DMA Channel Useburst Clear
#define DMAREQMASKCLR            (*(volatile U32 *) (DMA_BASE_ADDR + 0x024))
    // DMA Channel Request Mask Clear
#define DMAENASET                (*(volatile U32 *) (DMA_BASE_ADDR + 0x028))
    // DMA Channel Enable Set
#define DMAENACLR                (*(volatile U32 *) (DMA_BASE_ADDR + 0x02C))
    // DMA Channel Enable Clear
#define DMAALTCLR                (*(volatile U32 *) (DMA_BASE_ADDR + 0x034))
    // DMA Channel Primary Alternate Clear
#define DMAPRIOCLR               (*(volatile U32 *) (DMA_BASE_ADDR + 0x03C))
    // DMA Channel Priority Clear
#define DMACHMAP0                (*(volatile U32 *) (DMA_BASE_ADDR + 0x510))
    // DMA Channel Map Select 0

```

```

#define DMACHMAP1          (*(volatile U32 *) (DMA_BASE_ADDR + 0x514))
    // DMA Channel Map Select 1
#define DMACHMAP2          (*(volatile U32 *) (DMA_BASE_ADDR + 0x518))
    // DMA Channel Map Select 2
#define DMACHMAP3          (*(volatile U32 *) (DMA_BASE_ADDR + 0x51C))
    // DMA Channel Map Select 3

/*****
 *
 *      Flash controller
 */
#define FLASH_BASE_ADDR    0x400FD00uL
#define FLASHPP            (*(volatile U32 *) (FLASH_BASE_ADDR + 0xFC0))
    // Flash Peripheral Properties
#define FLASHDMASZ         (*(volatile U32 *) (FLASH_BASE_ADDR + 0xFD0))
    // Flash DMA Address Size
#define FLASHDMAST         (*(volatile U32 *) (FLASH_BASE_ADDR + 0xFD4))
    // Flash DMA Starting Address

/*****
 *
 *      Pin assignment
 */
#define CS_PIN              4        // Port H
#define CLK_PIN             0        // Port Q
#define DAT0_PIN            2        // Port Q
#define DAT1_PIN            0        // Port F

/*****
 *
 *      Flags in system registers
 */
#define RCGCSSI_SSI3        3
#define RCGCGPIO_GPIOF     5
#define RCGCGPIO_GPIOH     7
#define RCGCGPIO_GPIOQ    14

/*****
 *
 *      SSI related defines
 */
#define CR0_DSS              0
#define CR0_DSS_8BIT        7uL
#define CR0_SPO              6
#define CR0_SCR              8
#define CR0_SPH              7
#define CR0_SCR_MASK        0xFFuL
#define CR1_SSE              1
#define CR1_MODE             6
#define CR1_MODE_BI         1uL
#define CR1_MODE_QUAD       2uL
#define CR1_MODE_ADV         3uL
#define CR1_MODE_MASK       3uL
#define CR1_DIR              8
#define SR_TNF               1
#define SR_RNE               2
#define SR_BSY               4

/*****
 *
 *      DMA related defines
 */
#define DMA_MAX_TRANSFER_SIZE 1024    // in items
#define DMA_CHANNEL_READ    14
#define DMA_CHANNEL_WRITE   15
#define CHMAP1_SSI3_RX      2uL
#define CHMAP1_SSI3_TX      2uL
#define CHMAP_CHSEL_MASK    0xFuL
#define CHCTL_XFERMODE      0
#define CHCTL_XFERMODE_BASIC 1uL
#define CHCTL_XFERSIZE      4
#define CHCTL_XFERSIZE_MASK 0x3FFuL
#define CHCTL_ARBSIZE       14
#define CHCTL_ARBSIZE_4     2uL
#define CHCTL_SRCINC        26
#define CHCTL_SRCINC_NOINC  3uL

```

```

#define CHCTL_DSTINC          30
#define CHCTL_DSTINC_NOINC   3uL
#define DMACTL_RXDMAE        0
#define DMACTL_TXDMAE        1
#define CFG_MASTEREN         0
#define PP_DFA                28

/*****
 *
 *      Misc. defines
 */
#define DEFAULT_SPI_CLOCK_KHZ 400uL
#if (DMA_CHANNEL_READ < DMA_CHANNEL_WRITE)
    #define NUM_DMA_DESC      (DMA_CHANNEL_WRITE + 1)
#else
    #define NUM_DMA_DESC      (DMA_CHANNEL_READ + 1)
#endif

/*****
 *
 *      Local data types
 *
 *****/

/*****
 *
 *      DMA_DESC
 */
typedef struct DMA_DESC {
    volatile U32 SRCENDP;
    volatile U32 DESTENDP;
    volatile U32 CHCTL;
    volatile U32 Reserved;
} DMA_DESC;

/*****
 *
 *      Static data
 *
 *****/
static U8          _IsInited;
#if FS_MMC_HW_SPI_USE_DMA
    //
    // The DMA descriptors have to aligned on a 1KB boundary.
    //
#endif
#ifdef __ICCARM__
    #pragma data_alignment=1024
    static DMA_DESC _aDMADesc[NUM_DMA_DESC];
#endif
#ifdef __SES_ARM
    static DMA_DESC _aDMADesc[NUM_DMA_DESC] __attribute__((aligned(1024)));
#endif
static volatile U8 _Dummy;
#endif

/*****
 *
 *      Static code
 *
 *****/

/*****
 *
 *      _EnableClocks
 */
static void _EnableClocks(void) {
    U32 Timeout;

    //
    // Provide a clock to SSI module and wait for it to become ready.
    //
    RCGCSSI |= 1uL << RCGCSSI_SSI3;
    Timeout = FS_MMC_HW_SPI_WAIT_TIMEOUT_CYCLES;
}

```



```

while (1) {
    if (PRSSI & (1uL << RCGCSSI_SSI3)) {
        break;
    }
    if (--TimeOut == 0) {
        break;
    }
}
//
// Provide a clock to GPIO ports and wait for them to become ready.
//
RCGCGPIO |= 0
           | (1uL << RCGCGPIO_GPIOF)
           | (1uL << RCGCGPIO_GPIOH)
           | (1uL << RCGCGPIO_GPIOQ)
           ;
TimeOut = FS_MMC_HW_SPI_WAIT_TIMEOUT_CYCLES;
while (1) {

    if (PRGPIO & ((1uL << RCGCGPIO_GPIOF) | (1uL << RCGCGPIO_GPIOQ) | (1uL << RCGCGPIO_GPIOH))) {
        break;
    }
    if (--TimeOut == 0) {
        break;
    }
}
#ifdef FS_MMC_HW_SPI_USE_DMA
//
// Provide a clock to DMA controller and wait for it to become ready.
//
RCGCDMA |= 1uL << 0;
TimeOut = FS_MMC_HW_SPI_WAIT_TIMEOUT_CYCLES;
while (1) {
    if (PRDMA & ((1uL << 0))) {
        break;
    }
    if (--TimeOut == 0) {
        break;
    }
}
#endif
}

/*****
 *
 *      _InitPins
 */
static void _InitPins(void) {
    //
    // Give the control of CLK, DAT0-3 signals to SSI module.
    //
    PQ_GPIOAFSEL |= 0
                  | (1uL << CLK_PIN)
                  | (1uL << DAT0_PIN)
                  ;
    PF_GPIOAFSEL |= 0
                  | (1uL << DAT1_PIN)
                  ;
    PQ_GPIOPCTL  &= ~((0xFuL << (CLK_PIN << 2)) |
                     (0xFuL << (DAT0_PIN << 2)));
    PQ_GPIOPCTL  |= 0
                  | (0xEuL << (CLK_PIN << 2))
                  | (0xEuL << (DAT0_PIN << 2))
                  ;
    PF_GPIOPCTL  &= ~((0xFuL << (DAT1_PIN << 2)));
    PF_GPIOPCTL  |= 0
                  | (0xEuL << (DAT1_PIN << 2))
                  ;

    //
    // Set the output drive strength to 2mA as done in the TI sample code.
    //
    PQ_GPIOPC    &= ~((0x3uL << (CLK_PIN << 1)) |
                     (0x3uL << (DAT0_PIN << 1)));
    PF_GPIOPC    &= ~((0x3uL << (DAT1_PIN << 1)));
    PQ_GPIODR2R  |= 0
                  | (1uL << CLK_PIN)

```

```

        | (1uL << DAT0_PIN)
        ;
PQ_GPIODR4R &= ~( (0x1uL << CLK_PIN) |
                 (0x1uL << DAT0_PIN) );
PQ_GPIODR8R &= ~( (0x1uL << CLK_PIN) |
                 (0x1uL << DAT0_PIN) );
PF_GPIODR2R | = 0
        | (1uL << DAT1_PIN)
        ;
PF_GPIODR4R &= ~( (0x1uL << DAT1_PIN) );
PF_GPIODR8R &= ~( (0x1uL << DAT1_PIN) );
//
// Enable pull-ups on all signal lines.
//
PQ_GPIOPUR | = 0
        | (1uL << CLK_PIN)
        | (1uL << DAT0_PIN)
        ;
PF_GPIOPUR | = 0
        | (1uL << DAT1_PIN)
        ;
PQ_GPIODR &= ~( (0x1uL << CLK_PIN) |
                (0x1uL << DAT0_PIN) );
PF_GPIODR &= ~( (0x1uL << DAT1_PIN) );
PQ_GPIOPDR &= ~( (0x1uL << CLK_PIN) |
                (0x1uL << DAT0_PIN) );
PF_GPIOPDR &= ~( (0x1uL << DAT1_PIN) );
//
// Enable the pins.
//
PQ_GPIODEN | = 0
        | (1uL << CLK_PIN)
        | (1uL << DAT0_PIN)
        ;
PF_GPIODEN | = 0
        | (1uL << DAT1_PIN)
        ;

//
// The CS signal is controlled by the driver.
//
PH_GPIODIR | = 1uL << CS_PIN;
PH_GPIOAFSEL &= ~(1uL << CS_PIN);
PH_GPIOPUR &= ~(1uL << CS_PIN);
PH_GPIOPDR &= ~(1uL << CS_PIN);
PH_GPIODR &= ~(1uL << CS_PIN);
PH_GPIODEN | = 1uL << CS_PIN;
}

#if FS_MMC_HW_SPI_USE_DMA

/*****
 *
 *   _InitDMA
 */
static void _InitDMA(void) {
    DMACFG | = 1uL << CFG_MASTEREN; // Enable the DMA controller.
    DMACTLBASE = (U32)_aDMADesc; // The descriptor table must be
1024 aligned.
    DMAPRIOCLR = 0 // Set the priority to default.
        | (1uL << DMA_CHANNEL_READ)
        | (1uL << DMA_CHANNEL_WRITE)
        ;
    DMAALTCLR = 0
// Use the primary control structure in the DMA descriptor table.
        | (1uL << DMA_CHANNEL_READ)
        | (1uL << DMA_CHANNEL_WRITE)
        ;
    DMAUSEBURSTCLR = 0 // Respond to single and burst requests.
        | (1uL << DMA_CHANNEL_READ)
        | (1uL << DMA_CHANNEL_WRITE)
        ;
    DMAREQMASKCLR = 0 // Allow the recongition of requests.
        | (1uL << DMA_CHANNEL_READ)
        | (1uL << DMA_CHANNEL_WRITE)
        ;
}
//

```

```

// Receive requests from SSI.
//
DMACHMAP1      &= ~((CHMAP_CHSEL_MASK << ((DMA_CHANNEL_READ - 8) << 2)) |
                  (CHMAP_CHSEL_MASK << ((DMA_CHANNEL_WRITE - 8) << 2)));
DMACHMAP1      |= (CHMAP1_SSI3_RX << ((DMA_CHANNEL_READ - 8) << 2))
                  | (CHMAP1_SSI3_TX << ((DMA_CHANNEL_WRITE - 8) << 2))
                  ;

//
// Give DMA access to internal flash memory.
//
FLASHPP       |= 1uL << PP_DFA;
FLASHDMASZ    = 0x3FFFuL;
FLASHDMAST    = 0;           // Internal flash memory starts at address 0.
}

/*****
 *
 *      _StartDMAWrite
 */
static void _StartDMAWrite(const U8 * pData, U32 NumBytes) {
    U32      Timeout;
    U32      CHCTLReg;
    DMA_DESC * pDMADesc;

    //
    // Stop the DMA channels if required.
    //
    if (DMAENASET & ((1uL << DMA_CHANNEL_WRITE) | (1uL << DMA_CHANNEL_READ))) {
        DMAENACLR = 0
            | (1uL << DMA_CHANNEL_WRITE)
            | (1uL << DMA_CHANNEL_READ)
            ;
        Timeout = FS_MMC_HW_SPI_WAIT_TIMEOUT_CYCLES;
        while (1) {
            if ((DMAENASET & ((1uL << DMA_CHANNEL_WRITE) | (1uL << DMA_CHANNEL_READ))) == 0) {
                break;
            }
            if (--Timeout == 0) {
                break;
            }
        }
    }

    //
    // Configure the write data transfer.
    //
    NumBytes = (NumBytes - 1) & CHCTL_XFERSIZE_MASK;
    CHCTLReg = 0
        | (CHCTL_DSTINC_NOINC << CHCTL_DSTINC)
        | (CHCTL_ARBSIZE_4 << CHCTL_ARBSIZE)
        | (NumBytes << CHCTL_XFERSIZE)
        | (CHCTL_XFERMODE_BASIC << CHCTL_XFERMODE)
        ;

    //
    // Fill in the DMA descriptor.
    //
    pDMADesc = &_aDMADesc[DMA_CHANNEL_WRITE];
    pDMADesc->SRCENDP = (U32)(pData + NumBytes);
    pDMADesc->DESTENDP = (U32)&SSIDR;
    pDMADesc->CHCTL = CHCTLReg;
    //
    // Configure the read data transfer.
    //
    CHCTLReg = 0
        | (CHCTL_DSTINC_NOINC << CHCTL_DSTINC)
        | (CHCTL_SRCINC_NOINC << CHCTL_SRCINC)
        | (CHCTL_ARBSIZE_4 << CHCTL_ARBSIZE)
        | (NumBytes << CHCTL_XFERSIZE)
        | (CHCTL_XFERMODE_BASIC << CHCTL_XFERMODE)
        ;

    //
    // Fill in the DMA descriptor.
    //
    pDMADesc = &_aDMADesc[DMA_CHANNEL_READ];
    pDMADesc->SRCENDP = (U32)&SSIDR;
    pDMADesc->DESTENDP = (U32)&_Dummy;
    pDMADesc->CHCTL = CHCTLReg;
}

```

```

//
// Start the DMA transfer.
//
SSIDMACTL = 0
           | (1uL << DMACTL_RXDMAE)
           | (1uL << DMACTL_TXDMAE)
           ;
DMAENASET |= 0
           | (1uL << DMA_CHANNEL_READ)
           | (1uL << DMA_CHANNEL_WRITE)
           ;
}

/*****
*
*   _StartDMARead
*/
static void _StartDMARead(U8 * pData, U32 NumBytes) {
    U32 TimeOut;
    U32 CHCTLReg;
    DMA_DESC * pDMADesc;

    _Dummy = 0xFF;
    FS_USE_PARA(_Dummy);
    //
    // Stop the DMA channels if required.
    //
    if (DMAENASET & ((1uL << DMA_CHANNEL_WRITE) | (1uL << DMA_CHANNEL_READ))) {
        DMAENACL = 0
                 | (1uL << DMA_CHANNEL_WRITE)
                 | (1uL << DMA_CHANNEL_READ)
                 ;
        TimeOut = FS_MMC_HW_SPI_WAIT_TIMEOUT_CYCLES;
        while (1) {
            if ((DMAENASET & ((1uL << DMA_CHANNEL_WRITE) | (1uL << DMA_CHANNEL_READ))) == 0) {
                break;
            }
            if (--TimeOut == 0) {
                break;
            }
        }
    }
    //
    // Configure the write data transfer.
    //
    NumBytes = (NumBytes - 1) & CHCTL_XFERSIZE_MASK;
    CHCTLReg = 0
              | (CHCTL_DSTINC_NOINC << CHCTL_DSTINC)
              | (CHCTL_SRCINC_NOINC << CHCTL_SRCINC)
              | (CHCTL_ARBSIZE_4 << CHCTL_ARBSIZE)
              | (NumBytes << CHCTL_XFERSIZE)
              | (CHCTL_XFERMODE_BASIC << CHCTL_XFERMODE)
              ;

    //
    // Fill in the DMA descriptor.
    //
    pDMADesc = &_aDMADesc[DMA_CHANNEL_WRITE];
    pDMADesc->SRCENDP = (U32)&_Dummy;
    pDMADesc->DESTENDP = (U32)&SSIDR;
    pDMADesc->CHCTL = CHCTLReg;
    //
    // Configure the read data transfer.
    //
    CHCTLReg = 0
              | (CHCTL_SRCINC_NOINC << CHCTL_SRCINC)
              | (CHCTL_ARBSIZE_4 << CHCTL_ARBSIZE)
              | (NumBytes << CHCTL_XFERSIZE)
              | (CHCTL_XFERMODE_BASIC << CHCTL_XFERMODE)
              ;

    //
    // Fill in the DMA descriptor.
    //
    pDMADesc = &_aDMADesc[DMA_CHANNEL_READ];
    pDMADesc->SRCENDP = (U32)&SSIDR;
    pDMADesc->DESTENDP = (U32)(pData + NumBytes);
    pDMADesc->CHCTL = CHCTLReg;
}

```

```

//
// Start the DMA transfer.
//
SSIDMACTL = 0
           | (1uL << DMACTL_RXDMAE)
           | (1uL << DMACTL_TXDMAE)
           ;
DMAENASET |= 0
           | (1uL << DMA_CHANNEL_READ)
           | (1uL << DMA_CHANNEL_WRITE)
           ;
}

/*****
*
*   _WaitForEndOfDMAOperation
*/
static void _WaitForEndOfDMAOperation(void) {
    U32 TimeOut;

    TimeOut = FS_MMC_HW_SPI_WAIT_TIMEOUT_CYCLES;
    while (1) {
        if ((DMAENASET & (1uL << DMA_CHANNEL_READ)) == 0) {
            break;
        }
        if (--TimeOut == 0) {
            break;
        }
    }
}

#endif

/*****
*
*   _SetMaxSpeed
*/
static U16 _SetMaxSpeed(U16 MaxFreq_kHz) {
    U32 SCRValue;
    U32 CPSValue;
    U32 Factor;

    if (MaxFreq_kHz > FS_MMC_HW_SPI_MAX_SPI_CLOCK_KHZ) {
        MaxFreq_kHz = FS_MMC_HW_SPI_MAX_SPI_CLOCK_KHZ;
    }
    CPSValue = 0;
    Factor = (FS_MMC_HW_SPI_PERIPH_CLOCK_KHZ + (MaxFreq_kHz - 1)) / MaxFreq_kHz;
    do {
        CPSValue += 2;
        SCRValue = ((Factor + (CPSValue - 1)) / CPSValue) - 1;
    } while (SCRValue > 255);
    SSICPSR = CPSValue;
    SSICR0 &= ~(CR0_SCR_MASK << CR0_SCR);
    SSICR0 |= SCRValue << CR0_SCR;
    MaxFreq_kHz = (U16)(FS_MMC_HW_SPI_PERIPH_CLOCK_KHZ / (CPSValue * (1 + SCRValue)));
    return MaxFreq_kHz;
}

/*****
*
*   _Write
*/
static void _Write(const U8 * pData, int NumBytes) {
#if FS_MMC_HW_SPI_USE_DMA
    int NumBytesAtOnce;

    do {
        NumBytesAtOnce = SEGGER_MIN(NumBytes, DMA_MAX_TRANSFER_SIZE);
        _StartDMAWrite(pData, (U32)NumBytesAtOnce);
        _WaitForEndOfDMAOperation();
        NumBytes -= (int)NumBytesAtOnce;
        pData += NumBytesAtOnce;
    } while (NumBytes);
#else
    do {
        volatile U8 Dummy;

```

```

//
// Wait for room in FIFO.
//
while ((SSISR & (1uL << SR_TNF)) == 0) {
    ;
}
SSIDR = *pData++;
//
// Discard received data.
//
while ((SSISR & (1uL << SR_RNE)) == 0) {
    ;
}
Dummy = SSIDR;
FS_USE_PARA(Dummy);
} while (--NumBytes);
#endif
//
// Wait for the data transfer to finish.
//
while (SSISR & (1uL << SR_BSY)) {
    ;
}
}

/*****
*
*     _Read
*/
static void _Read(U8 * pData, int NumBytes) {
#if FS_MMC_HW_SPI_USE_DMA
    int NumBytesAtOnce;

    do {
        NumBytesAtOnce = SEGGER_MIN(NumBytes, DMA_MAX_TRANSFER_SIZE);
        _StartDMARead(pData, (U32)NumBytesAtOnce);
        _WaitForEndOfDMAOperation();
        NumBytes -= NumBytesAtOnce;
        pData    += NumBytesAtOnce;
    } while (NumBytes);
#else
    do {
        //
        // Wait for room in FIFO.
        //
        while ((SSISR & (1uL << SR_TNF)) == 0) {
            ;
        }
        SSIDR = 0xFF;
        //
        // Wait for some data to be received.
        //
        while ((SSISR & (1uL << SR_RNE)) == 0) {
            ;
        }
        *pData++ = (U8)SSIDR;
    } while (--NumBytes);
#endif
}

/*****
*
*     _Init
*/
static void _Init(void) {
    _EnableClocks();
    _InitPins();
    SSICR1 = 0;
    SSICR0 = 0
        | (CR0_DSS_8BIT << CR0_DSS)
        | (1uL << CR0_SPO)
        | (1uL << CR0_SPH)
        ;
    SSICC = 0;
    SSIICR = ~0uL;
    SSIIM = 0;
}

```

```

SSIDMACTL = 0;
(void)_SetMaxSpeed(DEFAULT_SPI_CLOCK_KHZ);
SSICR1 |= 1uL << CRI_SSE;
//
// Empty the receive queue.
//
while (1) {
    if ((SSISR & (1uL << SR_RNE)) == 0) {
        break;
    }
    (void)SSIDR;
}
#ifdef FS_MMC_HW_SPI_USE_DMA
    _InitDMA();
#endif
_IsInited = 1;
}

/*****
 *
 *      Public code (through callback)
 *
 *****/

/*****
 *
 *      _HW_EnableCS
 *
 *      Function description
 *      FS low level function. Sets the card slot active using the
 *      chip select (CS) line.
 *
 *      Parameters
 *      Unit      Device index
 */
static void _HW_EnableCS(U8 Unit) {
    volatile U32 * pReg;

    FS_USE_PARA(Unit);
    pReg = (volatile U32 *)((U8 *)&PH_GPIODATA + ((1uL << CS_PIN) << 2));
    *pReg = ~(1uL << CS_PIN);        // Active low
}

/*****
 *
 *      _HW_DisableCS
 *
 *      Function description
 *      FS low level function. Clears the card slot inactive using the
 *      chip select (CS) line.
 *
 *      Parameters
 *      Unit      Device index
 */
static void _HW_DisableCS(U8 Unit) {
    volatile U32 * pReg;

    FS_USE_PARA(Unit);
    pReg = (volatile U32 *)((U8 *)&PH_GPIODATA + ((1uL << CS_PIN) << 2));
    *pReg = 1uL << CS_PIN;        // Active low
}

/*****
 *
 *      _HW_IsWriteProtected
 *
 *      Function description
 *      FS low level function. Returns the state of the physical write
 *      protection of the SD cards.
 *
 *      Parameters
 *      Unit      Device index
 *
 *      Return value
 *      ==1      The card is write protected
 *****/

```

```

*   ==0       The card is not write protected
*/
static int _HW_IsWriteProtected(U8 Unit) {
    FS_USE_PARA(Unit);
    return 0;
}

/*****
*
*   _HW_SetMaxSpeed
*
*   Function description
*   FS low level function. Sets the SPI interface to a maximum frequency.
*   Make sure that you set the frequency lower or equal but never higher
*   than the given value. Recommended startup frequency is 100kHz - 400kHz.
*
*   Parameters
*   Unit       Device index
*   MaxFreq    SPI clock frequency in kHz
*
*   Return value
*   max. frequency    The maximum frequency set in kHz
*   ==0               The frequency could not be set
*/
static U16 _HW_SetMaxSpeed(U8 Unit, U16 MaxFreq) {
    FS_USE_PARA(Unit);
    MaxFreq = _SetMaxSpeed(MaxFreq);
    return MaxFreq;    // We are not faster than this.
}

/*****
*
*   _HW_SetVoltage
*
*   Function description
*   FS low level function. Be sure that your card slot is within the given
*   voltage range. Return 1 if your slot can support the required voltage,
*   and if not, return 0;
*
*   Parameters
*   Unit       Device index
*   Vmin       Minimum supply voltage supported by host
*   Vmax       Maximum supply voltage supported by host
*
*   Return value
*   ==1       The card slot supports the voltage range
*   ==0       The card slot does not support the voltage range
*/
static int _HW_SetVoltage(U8 Unit, U16 Vmin, U16 Vmax) {
    FS_USE_PARA(Unit);
    if ((FS_MMC_HW_SPI_DEFAULT_SUPPLY_VOLTAGE >= Vmin) && (FS_MMC_HW_SPI_DEFAULT_SUPPLY_VOLTAGE <= Vmax)) {
        return 1;    // Supply voltage supported.
    }
    return 0;    // Supply voltage not supported.
}

/*****
*
*   _HW_IsPresent
*
*   Function description
*   Returns the state of the media. If you do not know the state, return
*   FS_MEDIA_STATE_UNKNOWN and the higher layer will try to figure out if
*   a media is present.
*
*   Parameters
*   Unit       Device index
*
*   Return value
*   FS_MEDIA_STATE_UNKNOWN    Media state is unknown
*   FS_MEDIA_NOT_PRESENT     Media is not present
*   FS_MEDIA_IS_PRESENT      Media is present
*/
static int _HW_IsPresent(U8 Unit) {
    FS_USE_PARA(Unit);
    if (_IsInitiated == 0) {

```



```

    _Init();
}
return FS_MEDIA_IS_PRESENT;
}

/*****
 *
 *      _HW_Read
 *
 * Function description
 * FS low level function. Reads a specified number of bytes from MMC
 * card to buffer.
 *
 * Parameters
 * Unit      Device index
 * pData     Pointer to a data buffer
 * NumBytes  Number of bytes
 */
static void _HW_Read(U8 Unit, U8 * pData, int NumBytes) {
    FS_USE_PARA(Unit);
    _Read(pData, NumBytes);
}

/*****
 *
 *      _HW_Write
 *
 * Function description
 * FS low level function. Writes a specified number of bytes from
 * data buffer to the MMC/SD card.
 *
 * Parameters
 * Unit      Device index
 * pData     Pointer to a data buffer
 * NumBytes  Number of bytes
 */
static void _HW_Write(U8 Unit, const U8 * pData, int NumBytes) {
    FS_USE_PARA(Unit);
    _Write(pData, NumBytes);
}

/*****
 *
 *      Public data
 *
 *****/
const FS_MMC_HW_TYPE_SPI FS_MMC_HW_SPI_TM4C129_TI_TIVAC129 = {
    _HW_EnableCS,
    _HW_DisableCS,
    _HW_IsPresent,
    _HW_IsWriteProtected,
    _HW_SetMaxSpeed,
    _HW_SetVoltage,
    _HW_Read,
    _HW_Write,
    NULL,
    NULL,
    NULL,
    NULL
};

/***** End of file *****/

```

6.5.4.3 Hardware layer API - FS_MMC_HW_TYPE_CM

This hardware layer supports MMC cards and eMMC devices that comply with the version 4.x or newer of the MMC specification and SD cards of all types that are interfaced to the target MCU via a host controller that works in card mode. The functions of this hardware layer are grouped in a structure of type `FS_MMC_HW_TYPE_CM`. The following sections describe these functions in detail.

6.5.4.3.1 FS_MMC_HW_TYPE_CM

Description

Hardware layer API for Card Mode MMC/SD driver

Type definition

```
typedef struct {
    FS_MMC_HW_TYPE_CM_INIT                * pfInitHW;
    FS_MMC_HW_TYPE_CM_DELAY               * pfDelay;
    FS_MMC_HW_TYPE_CM_IS_PRESENT          * pfIsPresent;
    FS_MMC_HW_TYPE_CM_IS_WRITE_PROTECTED * pfIsWriteProtected;
    FS_MMC_HW_TYPE_CM_SET_MAX_SPEED       * pfSetMaxSpeed;
    FS_MMC_HW_TYPE_CM_SET_RESPONSE_TIMEOUT * pfSetResponseTimeOut;
    FS_MMC_HW_TYPE_CM_SET_READ_DATA_TIMEOUT * pfSetReadDataTimeOut;
    FS_MMC_HW_TYPE_CM_SEND_CMD            * pfSendCmd;
    FS_MMC_HW_TYPE_CM_GET_RESPONSE        * pfGetResponse;
    FS_MMC_HW_TYPE_CM_READ_DATA           * pfReadData;
    FS_MMC_HW_TYPE_CM_WRITE_DATA          * pfWriteData;
    FS_MMC_HW_TYPE_CM_SET_DATA_POINTER    * pfSetDataPointer;
    FS_MMC_HW_TYPE_CM_SET_BLOCK_LEN       * pfSetHWBlockLen;
    FS_MMC_HW_TYPE_CM_SET_NUM_BLOCKS      * pfSetHWNumBlocks;
    FS_MMC_HW_TYPE_CM_GET_MAX_READ_BURST * pfGetMaxReadBurst;
    FS_MMC_HW_TYPE_CM_GET_MAX_WRITE_BURST * pfGetMaxWriteBurst;
    FS_MMC_HW_TYPE_CM_GET_MAX_REPEAT_WRITE_BURST * pfGetMaxWriteBurstRepeat;
    FS_MMC_HW_TYPE_CM_GET_MAX_FILL_WRITE_BURST * pfGetMaxWriteBurstFill;
    FS_MMC_HW_TYPE_CM_SET_VOLTAGE         * pfSetVoltage;
    FS_MMC_HW_TYPE_CM_GET_VOLTAGE         * pfGetVoltage;
    FS_MMC_HW_TYPE_CM_SET_MAX_CLOCK       * pfSetMaxClock;
    FS_MMC_HW_TYPE_CM_ENABLE_TUNING       * pfEnableTuning;
    FS_MMC_HW_TYPE_CM_DISABLE_TUNING      * pfDisableTuning;
    FS_MMC_HW_TYPE_CM_START_TUNING        * pfStartTuning;
    FS_MMC_HW_TYPE_CM_GET_MAX_TUNINGS     * pfGetMaxTunings;
} FS_MMC_HW_TYPE_CM;
```

Structure members

Member	Description
pfInitHW	Initializes the hardware layer.
pfDelay	Blocks the execution for the specified time.
pfIsPresent	Checks if the card is inserted.
pfIsWriteProtected	Checks if the card is write protected.
pfSetMaxSpeed	Configures the clock frequency supplied to the card.
pfSetResponseTimeOut	Configures the maximum time to wait for a response from card.
pfSetReadDataTimeOut	Configures the maximum time to wait for data from card.
pfSendCmd	Sends a command to card.
pfGetResponse	Receives a response from card.
pfReadData	Transfers data from card to MCU.
pfWriteData	Transfers data from MCU to card.
pfSetDataPointer	Configures the pointer to the data to be exchanged.
pfSetHWBlockLen	Configures the size of the data block to be exchanged.
pfSetHWNumBlocks	Configures the number of data blocks to be exchanged.
pfGetMaxReadBurst	Returns the maximum number of data blocks that can be transferred at once from card to MCU.
pfGetMaxWriteBurst	Returns the maximum number of data blocks that can be transferred at once from MCU to card.

Member	Description
pfGetMaxWriteBurstRepeat	Returns the maximum number of blocks with identical data that can be transferred at once from MCU to card.
pfGetMaxWriteBurstFill	Returns the maximum number of blocks with identical data that can be transferred at once from MCU to card.
pfSetVoltage	Sets the voltage level of I/O lines.
pfGetVoltage	Returns the voltage level of I/O lines.
pfSetMaxClock	Configures the clock frequency supplied to the card.
pfEnableTuning	Enables the tuning procedure.
pfDisableTuning	Disables the tuning procedure.
pfStartTuning	Indicates the beginning of a tuning sequence.
pfGetMaxTunings	Returns the maximum number of tuning sequences.

6.5.4.3.2 FS_MMC_HW_TYPE_CM_INIT

Description

Initializes the hardware layer.

Type definition

```
typedef void FS_MMC_HW_TYPE_CM_INIT(U8 Unit);
```

Parameters

Parameter	Description
<code>Unit</code>	Index of the hardware layer instance (0-based)

Additional information

This function is a member of the Card Mode MMC/SD hardware layer. It has to be implemented by all the hardware layers.

The Card Mode MMC/SD driver calls `FS_MMC_HW_TYPE_CM_INIT` before any other function of the hardware layer. `FS_MMC_HW_TYPE_CM_INIT` must perform any steps required to initialize the target hardware such as enabling the clocks, setting up special function registers, etc.

6.5.4.3.3 FS_MMC_HW_TYPE_CM_DELAY

Description

Blocks the execution for the specified time.

Type definition

```
typedef void FS_MMC_HW_TYPE_CM_DELAY(int ms);
```

Parameters

Parameter	Description
<code>ms</code>	Number of milliseconds to block the execution.

Additional information

This function is a member of the Card Mode MMC/SD hardware layer. It has to be implemented by all the hardware layers.

The specified time is a minimum delay. The actual delay is permitted to be longer. This can be helpful when using an RTOS. Every RTOS has a delay API function, but the accuracy is typically 1 tick, which is 1 `ms` in most cases. Therefore, a delay of 1 tick is typically between 0 and 1 `ms`. To compensate for this, the equivalent of 1 tick should be added to the delay parameter before passing it to an RTOS delay function.

6.5.4.3.4 FS_MMC_HW_TYPE_CM_IS_PRESENT

Description

Checks if the card is present.

Type definition

```
typedef int FS_MMC_HW_TYPE_CM_IS_PRESENT(U8 Unit);
```

Parameters

Parameter	Description
<code>Unit</code>	Index of the hardware layer instance (0-based)

Return value

<code>FS_MEDIA_STATE_UNKNOWN</code>	The presence state of the card is unknown.
<code>FS_MEDIA_NOT_PRESENT</code>	The card is present.
<code>FS_MEDIA_IS_PRESENT</code>	The card is not present.

Additional information

This function is a member of the Card Mode MMC/SD hardware layer. It has to be implemented by all the hardware layers.

Typically, the card presence detection is implemented via a dedicated Card Detect (CD) signal. This signal is connected to a switch inside the card slot that changes its state each time the card is removed or inserted. If the hardware does not provide such signal the function has to return `FS_MEDIA_STATE_UNKNOWN`.

6.5.4.3.5 FS_MMC_HW_TYPE_CM_IS_WRITE_PROTECTED

Description

Checks if the card is write protected.

Type definition

```
typedef int FS_MMC_HW_TYPE_CM_IS_WRITE_PROTECTED(U8 Unit);
```

Parameters

Parameter	Description
Unit	Index of the hardware layer instance (0-based)

Return value

- = 0 The card data can be modified.
- ≠ 0 The card data cannot be modified.

Additional information

This function is a member of the Card Mode MMC/SD hardware layer. It has to be implemented by all the hardware layers.

Typically, the card protection status is implemented via a dedicated Write Protected (WP) signal. This signal is connected to a switch inside the card slot that reflects the status of the write protect switch found on SD cards. If the hardware does not provide such signal the function has to return 0.

eMMC devices and micro SD cards do not have a write protection switch. Please note that the write protect switch does not really protect the data on an SD card from being modified. It is merely an indication that the data has to be protected. It is the responsibility of the host MCU to respect the status of this switch.

6.5.4.3.6 FS_MMC_HW_TYPE_CM_SET_MAX_SPEED

Description

Configures the clock frequency supplied to the card.

Type definition

```
typedef U16 FS_MMC_HW_TYPE_CM_SET_MAX_SPEED(U8 Unit,
                                             U16 MaxFreq);
```

Parameters

Parameter	Description
<code>Unit</code>	Index of the hardware layer instance (0-based)
<code>MaxFreq</code>	Maximum allowed frequency of the bus clock in kHz.

Return value

- ≠ 0 The actual clock frequency in kHz.
- = 0 An error occurred.

Additional information

This function is a member of the Card Mode MMC/SD hardware layer. It has to be implemented by all the hardware layers.

The hardware layer is allowed to set a clock frequency smaller than the value specified via `MaxFreq` but never greater than that. The Card Mode MMC/SD driver calls this function at least two times during the initialization of the MMC or SD card:

- Before the initialization starts to set the clock frequency to 400 kHz.
- After the card identification to set the standard clock frequency which is 25 MHz for SD cards or 26 MHz for MMC cards and eMMC devices.

`FS_MMC_HW_TYPE_CM_SPI_SET_MAX_SPEED` is called a third time by the Card Mode MMC/SD driver during the initialization if the high speed mode is enabled in the driver via `FS_MM-C_CM_AllowHighSpeedMode()` and the card supports this mode. In this case the clock frequency is set to 50 MHz for SD cards and to 52 MHz for MMC cards and eMMC devices.

The function has to return the actual configured clock frequency. If the precise frequency is unknown such as for implementation using I/O port "bit-banging", the return value has to be less than the specified frequency. This may lead to longer timeout values but is in general does not cause any problems. The Card Mode MMC/SD driver uses the returned value to calculate timeout values.

6.5.4.3.7 FS_MMC_HW_TYPE_CM_SET_RESPONSE_TIMEOUT

Description

Configures the maximum time to wait for a response from card.

Type definition

```
typedef void FS_MMC_HW_TYPE_CM_SET_RESPONSE_TIMEOUT(U8 Unit,  
                                                    U32 Value);
```

Parameters

Parameter	Description
Unit	Index of the hardware layer instance (0-based)
Value	Number of clock cycles to wait.

Additional information

This function is a member of the Card Mode MMC/SD hardware layer. It has to be implemented by all the hardware layers.

The specified value is the maximum number of clock cycles the hardware layer has to wait for a response from the card. If the card does not respond within the specified timeout then `FS_MMC_HW_TYPE_CM_GET_RESPONSE` has to return an error to the Card Mode MMC/SD driver.

6.5.4.3.8 FS_MMC_HW_TYPE_CM_SET_READ_DATA_TIMEOUT

Description

Configures the maximum time to wait for data from card.

Type definition

```
typedef void FS_MMC_HW_TYPE_CM_SET_READ_DATA_TIMEOUT(U8 Unit,
                                                    U32 Value);
```

Parameters

Parameter	Description
Unit	Index of the hardware layer instance (0-based)
Value	Number of clock cycles to wait.

Additional information

This function is a member of the Card Mode MMC/SD hardware layer. It has to be implemented by all the hardware layers.

The specified value is the maximum number of clock cycles the hardware layer has to wait for data to be received from the card. If the card does not start sending the data within the specified timeout then `FS_MMC_HW_TYPE_CM_READ_DATA` has to return an error to the Card Mode MMC/SD driver. The timeout value specified via `FS_MMC_HW_TYPE_CM_SET_READ_DATA_TIMEOUT` has to be used as timeout for a write data operation if the MMC/SD host controller supports this feature.

6.5.4.3.9 FS_MMC_HW_TYPE_CM_SEND_CMD

Description

Sends a command to card.

Type definition

```
typedef void FS_MMC_HW_TYPE_CM_SEND_CMD(U8      Unit,
                                         unsigned Cmd,
                                         unsigned CmdFlags,
                                         unsigned ResponseType,
                                         U32      Arg);
```

Parameters

Parameter	Description
Unit	Index of the hardware layer instance (0-based)
Cmd	Command code.
CmdFlags	Command options.
ResponseType	Type of response expected.
Arg	Command arguments.

Additional information

This function is a member of the Card Mode MMC/SD hardware layer. It has to be implemented by all the hardware layers.

[Cmd](#) is a command code defined in the SD or MMC specification.

[CmdFlags](#) specifies additional information about the command execution such as the direction of the data transfer if any, the number of data lines to be used for the data exchange, etc. [CmdFlags](#) is a bitwise-or combination of *Card mode command flags* on page 1087

[ResponseType](#) specifies the format of the response expected for the sent command. It can be one of *Card mode response formats* on page 1090. If the command requests a response from the card then the Card Mode MMC/SD driver calls `FS_MMC_HW_TYPE_CM_GET_RESPONSE` to get it.

[Arg](#) is the value that is stored at the bit positions 8:39 in a command codeword.

A command codeword is always sent via the CMD signal. The same signal is used by a card to send a response back to MCU.

6.5.4.3.10 FS_MMC_HW_TYPE_CM_GET_RESPONSE

Description

Receives a response from card.

Type definition

```
typedef int FS_MMC_HW_TYPE_CM_GET_RESPONSE(U8      Unit,
                                           void *  pData,
                                           U32     NumBytes);
```

Parameters

Parameter	Description
<code>Unit</code>	Index of the hardware layer instance (0-based)
<code>pData</code>	<code>out</code> Received response.
<code>NumBytes</code>	Number of bytes to be received.

Return value

= 0 OK, response received.
 ≠ 0 Error code indicating the failure reason.

Additional information

This function is a member of the Card Mode MMC/SD hardware layer. It has to be implemented by all the hardware layers.

The response is sent by the card via the CMD signal. A response codeword can be either 48- or 136-bit large.

Refer to *Card mode error codes* on page 1089 for possible return values.

The MMC and SD specifications describe the structure of a response in terms of bit units with bit 0 being the first transmitted via the CMD signal. The following table shows at which byte offsets the response has to be stored to `pData`.

48-bit response:

Byte offset <code>pData</code>	Bit range response
0	47-40
1	39-32
2	31-24
3	23-16
4	15-8
5	7-0

136-bit response:

Byte offset <code>pData</code>	Bit range response
0	135-128
1	127-120
2	119-112
3	111-104
4	103-96
5	95-88
6	87-80

Byte offset <code>pData</code>	Bit range response
7	79-72
8	71-64
9	63-56
10	55-48
11	47-40
12	39-32
13	31-24
14	23-16
15	15-8
16	7-0

The first and last byte of a response codeword store control and check information that is not used by the Card Mode MMC/SD driver. If this information is not provided by the SD and MMC host controller then the hardware layer does not have to store any data to these locations of `pData`. That is the response data must be stored at byte offset 1 in `pData`.

6.5.4.3.11 FS_MMC_HW_TYPE_CM_READ_DATA

Description

Transfers data from card to MCU.

Type definition

```
typedef int FS_MMC_HW_TYPE_CM_READ_DATA(U8      Unit,
                                         void   * pData,
                                         unsigned BlockSize,
                                         unsigned NumBlocks);
```

Parameters

Parameter	Description
Unit	Index of the hardware layer instance (0-based)
pData	out Data read from the card.
BlockSize	Number of bytes in a block to be transferred.
NumBlocks	Number of blocks be transferred.

Return value

- = 0 OK, data read.
- ≠ 0 Error code indicating the failure reason.

Additional information

This function is a member of the Card Mode MMC/SD hardware layer. It has to be implemented by all the hardware layers.

The Card Mode MMC/SD driver initiates a data transfer by sending a read command via `FS_MMC_HW_TYPE_CM_SEND_CMD`. After it checks the response via `FS_MMC_HW_TYPE_CM_GET_RESPONSE` the Card Mode MMC/SD driver calls `FS_MMC_HW_TYPE_CM_READ_DATA` to transfer the data from card.

Typically, an MMC or SD host controller transfers the data one block at a time. `BlockSize` specifies the size of one block in bytes with the number of blocks being specified via `NumBlocks`. `BlockSize` and `NumBlocks` can never be 0. Typically the size of block is 512 bytes but during the initialization of the card the Card Mode MMC/SD driver can request blocks of different (smaller) sizes. The total number of bytes to be transferred by `FS_MMC_HW_TYPE_CM_READ_DATA` is `BlockSize * NumBlocks`.

The number of data signals to be used for the data transfer is specified by the Card Mode MMC/SD driver via the command flags when the command that initiates the read operation is sent. `FS_MMC_CMD_FLAG_USE_SD4MODE` is set in the command flags when the data has to be exchanged via 4 data signals. This flag can be set for SD cards as well as MMC devices. `FS_MMC_CMD_FLAG_USE_MMC8MODE` is set only for MMC devices to transfer the data via 8 data signals.

Refer to *Card mode error codes* on page 1089 for possible return values.

6.5.4.3.12 FS_MMC_HW_TYPE_CM_WRITE_DATA

Description

Transfers data from MCU to card.

Type definition

```
typedef int FS_MMC_HW_TYPE_CM_WRITE_DATA(
    U8 Unit,
    const void * pData,
    unsigned BlockSize,
    unsigned NumBlocks);
```

Parameters

Parameter	Description
Unit	Index of the hardware layer instance (0-based)
pData	in Data to be written to card.
BlockSize	Number of bytes in a block to be transferred.
NumBlocks	Number of blocks be transferred.

Return value

- = 0 OK, data written.
- ≠ 0 Error code indicating the failure reason.

Additional information

This function is a member of the Card Mode MMC/SD hardware layer. It has to be implemented by all the hardware layers.

The Card Mode MMC/SD driver initiates a data transfer by sending a write command via `FS_MMC_HW_TYPE_CM_SEND_CMD`. After it checks the response via `FS_MMC_HW_TYPE_CM_GET_RESPONSE` the Card Mode MMC/SD driver calls `FS_MMC_HW_TYPE_CM_WRITE_DATA` to transfer the data to card.

Typically, an MMC or SD host controller transfers the data one block at a time. `BlockSize` specifies the size of one block in bytes with the number of blocks being specified via `NumBlocks`. `BlockSize` and `NumBlocks` can never be 0. Typically the size of block is 512 bytes but during the initialization of the card the Card Mode MMC/SD driver can request blocks of different (smaller) sizes. The total number of bytes to be transferred by `FS_MMC_HW_TYPE_CM_WRITE_DATA` is `BlockSize * NumBlocks`.

The number of data signals to be used for the data transfer is specified by the Card Mode MMC/SD driver via the command flags when the command that initiates the write operation is sent. `FS_MMC_CMD_FLAG_USE_SD4MODE` is set in the command flags when the data has to be exchanged via 4 data signals. This flag can be set for SD cards as well as MMC devices. `FS_MMC_CMD_FLAG_USE_MMC8MODE` is set only for MMC devices to transfer the data via 8 data signals.

Refer to *Card mode error codes* on page 1089 for possible return values.

6.5.4.3.13 FS_MMC_HW_TYPE_CM_SET_DATA_POINTER

Description

Configures the pointer to the data to be exchanged.

Type definition

```
typedef void FS_MMC_HW_TYPE_CM_SET_DATA_POINTER(      U8      Unit,
                                                    const void * pData);
```

Parameters

Parameter	Description
<code>Unit</code>	Index of the hardware layer instance (0-based)
<code>pData</code>	Data exchanged with the card.

Additional information

This function is a member of the Card Mode MMC/SD hardware layer. It has to be implemented only by a hardware layer that has to prepare the data transfer such as via DMA before the read or write command that initiates that data transfer is sent to card.

`FS_MMC_HW_TYPE_CM_SET_DATA_POINTER` is called by the Card Mode MMC/SD driver before each command that exchanges the data with the card. `pData` points to the same memory region as `pData` passed to `FS_MMC_HW_TYPE_CM_READ_DATA` and `FS_MMC_HW_TYPE_CM_WRITE_DATA`.

6.5.4.3.14 FS_MMC_HW_TYPE_CM_SET_BLOCK_LEN

Description

Configures the size of the data block to be exchanged.

Type definition

```
typedef void FS_MMC_HW_TYPE_CM_SET_BLOCK_LEN(U8 Unit,
                                             U16 BlockSize);
```

Parameters

Parameter	Description
Unit	Index of the hardware layer instance (0-based)
BlockSize	Number of bytes in the block.

Additional information

This function is a member of the Card Mode MMC/SD hardware layer. It has to be implemented only by a hardware layer that has to prepare the data transfer such as via DMA before the read or write command that initiates that data transfer is sent to card.

FS_MMC_HW_TYPE_CM_SET_BLOCK_LEN is called by the Card Mode MMC/SD driver before each command that exchanges the data with the card. The same value is passed via [BlockSize](#) as the value passed via [BlockSize](#) to FS_MMC_HW_TYPE_CM_READ_DATA and FS_MM-C_HW_TYPE_CM_WRITE_DATA.

6.5.4.3.15 FS_MMC_HW_TYPE_CM_SET_NUM_BLOCKS

Description

Configures the number of data blocks to be exchanged.

Type definition

```
typedef void FS_MMC_HW_TYPE_CM_SET_NUM_BLOCKS(U8 Unit,
                                               U16 NumBlocks);
```

Parameters

Parameter	Description
Unit	Index of the hardware layer instance (0-based)
NumBlocks	Number of bytes to be exchanged.

Additional information

This function is a member of the Card Mode MMC/SD hardware layer. It has to be implemented only by a hardware layer that has to prepare the data transfer such as via DMA before the read or write command that initiates that data transfer is sent to card.

`FS_MMC_HW_TYPE_CM_SET_NUM_BLOCKS` is called by the Card Mode MMC/SD driver before each command that exchanges the data with the card. The same value is passed via [NumBlocks](#) as the value passed via [NumBlocks](#) to `FS_MMC_HW_TYPE_CM_READ_DATA` and `FS_MMC_HW_TYPE_CM_WRITE_DATA`.

6.5.4.3.16 FS_MMC_HW_TYPE_CM_GET_MAX_READ_BURST

Description

Returns the maximum number of data blocks that can be transferred at once from card to MCU.

Type definition

```
typedef U16 FS_MMC_HW_TYPE_CM_GET_MAX_READ_BURST(U8 Unit);
```

Parameters

Parameter	Description
Unit	Index of the hardware layer instance (0-based)

Return value

Number of blocks that can be transferred at once. It cannot be 0.

Additional information

This function is a member of the Card Mode MMC/SD hardware layer. It has to be implemented by all the hardware layers.

FS_MMC_HW_TYPE_CM_GET_MAX_READ_BURST is called by the Card Mode MMC/SD driver during initialization. It has to return the maximum number of 512 byte blocks the hardware layer is able to transfer from the card via a single read command. The larger the number of blocks the hardware layer can exchange at once the better is the read performance.

6.5.4.3.17 FS_MMC_HW_TYPE_CM_GET_MAX_WRITE_BURST

Description

Returns the maximum number of data blocks that can be transferred at once from MCU to card.

Type definition

```
typedef U16 FS_MMC_HW_TYPE_CM_GET_MAX_WRITE_BURST(U8 Unit);
```

Parameters

Parameter	Description
Unit	Index of the hardware layer instance (0-based)

Return value

Number of blocks that can be transferred at once. It cannot be 0.

Additional information

This function is a member of the Card Mode MMC/SD hardware layer. It has to be implemented by all the hardware layers.

FS_MMC_HW_TYPE_CM_GET_MAX_WRITE_BURST is called by the Card Mode MMC/SD driver during initialization. It has to return the maximum number of 512 byte blocks the hardware layer is able to transfer to the card via a single write command. The larger the number of blocks the hardware layer can exchange at once the better is the write performance.

6.5.4.3.18 FS_MMC_HW_TYPE_CM_GET_MAX_REPEAT_WRITE_BURST

Description

Returns the maximum number of blocks of identical data that can be transferred from MCU to card.

Type definition

```
typedef U16 FS_MMC_HW_TYPE_CM_GET_MAX_REPEAT_WRITE_BURST(U8 Unit);
```

Parameters

Parameter	Description
Unit	Index of the hardware layer instance (0-based)

Return value

Number of blocks that can be transferred at once.

Additional information

This function is a member of the Card Mode MMC/SD hardware layer. A hardware layer is not required to implement this function.

FS_MMC_HW_TYPE_CM_GET_MAX_REPEAT_WRITE_BURST is called by the Card Mode MMC/SD driver during initialization. It has to return the maximum number of 512 byte blocks the hardware layer is able to repeatedly transfer to the card via a single write command. The command that starts a repeated write operation has FS_MMC_CMD_FLAG_WRITE_BURST_REPEAT set in the command flags passed to FS_MMC_HW_TYPE_CM_SEND_CMD. The Card Mode MMC/SD driver transfers the data by calling FS_MMC_HW_TYPE_CM_WRITE_DATA with pData always pointing to a single block of BlockSize regardless of the NumBlock value. That FS_MMC_HW_TYPE_CM_WRITE_DATA does not have to increment pData by BlockSize after each block transfer. The larger the number of blocks the hardware layer can exchange at once the better is the write performance.

A return value of 0 indicates that the feature is not supported.

6.5.4.3.19 FS_MMC_HW_TYPE_CM_GET_MAX_FILL_WRITE_BURST

Description

Returns the maximum number of blocks of identical data that can be transferred from MCU to card.

Type definition

```
typedef U16 FS_MMC_HW_TYPE_CM_GET_MAX_FILL_WRITE_BURST(U8 Unit);
```

Parameters

Parameter	Description
Unit	Index of the hardware layer instance (0-based)

Return value

Number of blocks that can be transferred at once.

Additional information

This function is a member of the Card Mode MMC/SD hardware layer. A hardware layer is not required to implement this function.

FS_MMC_HW_TYPE_CM_GET_MAX_FILL_WRITE_BURST is called by the Card Mode MMC/SD driver during initialization. It has to return the maximum number of 512 byte blocks the hardware layer is able to repeatedly transfer to the card via a single write command. The command that starts a repeated write operation has FS_MMC_CMD_FLAG_WRITE_BURST_FILL set in the command flags passed to FS_MMC_HW_TYPE_CM_SEND_CMD. The Card Mode MMC/SD driver transfers the data by calling FS_MMC_HW_TYPE_CM_WRITE_DATA with pData always pointing to a single block of BlockSize regardless of the NumBlocks value. FS_MMC_HW_TYPE_CM_GET_MAX_FILL_WRITE_BURST has to take the first four bytes from pData and send them repeatedly to card until BlockSize * NumBlocks are sent. Typically this operation is realized by using DMA configured to transfer four bytes at once and without incrementing the destination address. The larger the number of blocks the hardware layer can exchange at once the better is the write performance.

A return value of 0 indicates that the feature is not supported.

6.5.4.3.20 FS_MMC_HW_TYPE_CM_SET_VOLTAGE

Description

Changes the voltage level of the I/O lines.

Type definition

```
typedef int FS_MMC_HW_TYPE_CM_SET_VOLTAGE(U8 Unit,
                                           U16 VMin,
                                           U16 VMax,
                                           int IsSwitchSequence);
```

Parameters

Parameter	Description
<code>Unit</code>	Index of the hardware layer instance (0-based)
<code>VMin</code>	Minimum voltage of I/O lines to be set.
<code>VMax</code>	Maximum voltage of I/O lines to be set.
<code>IsSwitchSequence</code>	Specifies if a voltage switch sequence has to be performed according to SD specification. <ul style="list-style-type: none"> • 1 Voltage switch sequence has to be performed. • 0 No voltage switch sequence is required.

Return value

= 0 OK, voltage switched successfully.
≠ 0 Error code indicating the failure reason.

Additional information

This function is a member of the Card Mode MMC/SD hardware layer. A hardware layer has to implement this function if the hardware supports 1.8 V signaling and the application enables any ultra high speed mode in the Card Mode MMC/SD driver.

The values of `VMin` and `VMax` are specified in mV with `VMin` always smaller than or equal to `VMax`.

`IsSwitchSequence` is set to 1 only if an SD card is connected. For MMC cards or eMMC devices `IsSwitchSequence` is always set to 0. If `IsSwitchSequence` is set to 1 then the function has to wait for the SD card to change the voltage level of the I/O lines as follows:

- Wait for the SD card to drive either the CMD or one of the DAT lines to low.
- Stop providing clock to SD card.
- Wait for the SD card to start the switch sequence by checking if either the CMD or one of the DAT lines to low.
- Wait at least 5 ms.
- Start providing the clock to SD card using a 1.8 V voltage level.
- Wait at least 1 ms.
- Check if the SD card drives one of the DAT lines to high. This function has to wait for the power to stabilize before it returns.

Refer to *Card mode error codes* on page 1089 for possible return values.

6.5.4.3.21 FS_MMC_HW_TYPE_CM_GET_VOLTAGE

Description

Returns the current voltage level of the I/O lines.

Type definition

```
typedef U16 FS_MMC_HW_TYPE_CM_GET_VOLTAGE(U8 Unit);
```

Parameters

Parameter	Description
Unit	Index of the hardware layer instance (0-based)

Return value

≠ 0 OK, voltage level of I/O lines in mV.
= 0 An error occurred.

Additional information

This function is a member of the Card Mode MMC/SD hardware layer. A hardware layer has to implement this function if the hardware supports 1.8 V signaling and the application enables any ultra high speed mode in the Card Mode MMC/SD driver.

6.5.4.3.22 FS_MMC_HW_TYPE_CM_SET_MAX_CLOCK

Description

Configures the clock frequency supplied to the card.

Type definition

```
typedef U32 FS_MMC_HW_TYPE_CM_SET_MAX_CLOCK(U8      Unit,
                                             U32      MaxFreq,
                                             unsigned Flags);
```

Parameters

Parameter	Description
Unit	Index of the hardware layer instance (0-based)
MaxFreq	Maximum allowed frequency of the bus clock in kHz.
ClkFlags	Additional clock generation options.

Return value

≠ 0 The actual clock frequency in kHz.
= 0 An error occurred.

Additional information

This function is a member of the Card Mode MMC/SD hardware layer. A hardware layer has to implement this function if the hardware supports 1.8 V signaling and the application enables any ultra high speed mode in the Card Mode MMC/SD driver.

The hardware layer is allowed to set a clock frequency smaller than the value specified via [MaxFreq](#) but never greater than that.

[FS_MMC_HW_TYPE_CM_SPI_SET_MAX_SPEED_EX](#) is similar to [FS_MMC_HW_TYPE_CM_SPI_SET_MAX_SPEED](#) with the exception that it allows the configuration of a clock frequency greater than 65535 kHz which is required by some of the ultra high speed modes. In addition, [FS_MMC_HW_TYPE_CM_SPI_SET_MAX_SPEED_EX](#) has the ability to configure if the data received from the card has to be sampled on one clock edge or on both clock edges.

[ClkFlags](#) is a bitwise-or combination of *Card mode clock flags* on page 1088 that specifies for example how the data has to be sampled.

6.5.4.3.23 FS_MMC_HW_TYPE_CM_ENABLE_TUNING

Description

Stops the normal operation and enters the tuning procedure.

Type definition

```
typedef int FS_MMC_HW_TYPE_CM_ENABLE_TUNING(U8 Unit);
```

Parameters

Parameter	Description
Unit	Index of the hardware layer instance (0-based)

Return value

= 0 OK, tuning procedure activated.
 ≠ 0 An error occurred.

Additional information

This function is a member of the Card Mode MMC/SD hardware layer. A hardware layer has to implement this function if the hardware supports 1.8 V signaling and the application enables an ultra high speed mode that requires the tuning of the data sampling point.

FS_MMC_HW_TYPE_CM_ENABLE_TUNING is called by the Card Mode MMC/SD driver one time at the beginning of the tuning procedure. The call to this function is followed by one or more calls to FS_MMC_HW_TYPE_CM_START_TUNING. FS_MMC_HW_TYPE_CM_DISABLE_TUNING is called at the end of the tuning procedure.

Typically, this function can be used to enabled the delay line loop that is used for generating the sampling clock.

Refer to *Card mode error codes* on page 1089 for possible return values.

6.5.4.3.24 FS_MMC_HW_TYPE_CM_DISABLE_TUNING

Description

Restores the normal operation after the tuning procedure.

Type definition

```
typedef int FS_MMC_HW_TYPE_CM_DISABLE_TUNING(U8 Unit,
                                             int Result);
```

Parameters

Parameter	Description
<code>Unit</code>	Index of the hardware layer instance (0-based)
<code>Result</code>	Specifies if the tuning procedure was successful or not. <ul style="list-style-type: none"> • 0 - The tuning procedure was successful. • 1 - The tuning procedure failed.

Return value

= 0 OK, tuning procedure deactivated.
 ≠ 0 An error occurred.

Additional information

This function is a member of the Card Mode MMC/SD hardware layer. A hardware layer has to implement this function if the hardware supports 1.8 V signaling and the application enables an ultra high speed mode that requires the tuning of the data sampling point.

`FS_MMC_HW_TYPE_CM_DISABLE_TUNING` is called by the Card Mode MMC/SD driver one time at the end of the tuning procedure.

Typically, this function can be used to disable the delay line loop that is used for generating the sampling clock when the tuning procedure fails.

Refer to *Card mode error codes* on page 1089 for possible return values.

6.5.4.3.25 FS_MMC_HW_TYPE_CM_START_TUNING

Description

Indicates the beginning of a tuning sequence.

Type definition

```
typedef int FS_MMC_HW_TYPE_CM_START_TUNING(U8 Unit,
                                           unsigned TuningIndex);
```

Parameters

Parameter	Description
<code>Unit</code>	Index of the hardware layer instance (0-based)
<code>TuningIndex</code>	Index of the current tuning sequence (0-based)

Return value

= 0 OK, tuning sequence failed.
 ≠ 0 An error occurred.

Additional information

This function is a member of the Card Mode MMC/SD hardware layer. A hardware layer has to implement this function if the hardware supports 1.8 V signaling and the application enables an ultra high speed mode that requires the tuning of the data sampling point.

`FS_MMC_HW_TYPE_CM_START_TUNING` is called by the Card Mode MMC/SD driver one time at the beginning of each tuning sequence. On the first call `TuningIndex` is set to 0, on the second to 1 and so on. The maximum value of `TuningIndex` is the value returned by `FS_MMC_HW_TYPE_CM_GET_MAX_TUNINGS` minus 1. `TuningIndex` can be used for example to select a different delay line unit.

Refer to *Card mode error codes* on page 1089 for possible return values.

6.5.4.3.26 FS_MMC_HW_TYPE_CM_GET_MAX_TUNINGS

Description

Queries the maximum number of tuning sequences.

Type definition

```
typedef U16 FS_MMC_HW_TYPE_CM_GET_MAX_TUNINGS(U8 Unit);
```

Parameters

Parameter	Description
<code>Unit</code>	Index of the hardware layer instance (0-based)

Return value

≠ 0 OK, maximum number of tuning sequences.
 = 0 An error occurred.

Additional information

This function is a member of the Card Mode MMC/SD hardware layer. A hardware layer has to implement this function if the hardware supports 1.8 V signaling and the application enables an ultra high speed mode that requires the tuning of the data sampling point.

`FS_MMC_HW_TYPE_CM_GET_MAX_TUNINGS` is called by the Card Mode MMC/SD driver one time at the beginning of the tuning procedure after the call to `FS_MMC_HW_TYPE_CM_ENABLE_TUNING`.

The return value can be for example the number of delay line units available.

6.5.4.3.27 Card mode command flags

Description

Additional options for the executed command.

Definition

```
#define FS_MMC_CMD_FLAG_DATATRANSFER      (1uL << 0)
#define FS_MMC_CMD_FLAG_WRITETRANSFER    (1uL << 1)
#define FS_MMC_CMD_FLAG_SETBUSY          (1uL << 2)
#define FS_MMC_CMD_FLAG_INITIALIZE        (1uL << 3)
#define FS_MMC_CMD_FLAG_USE_SD4MODE      (1uL << 4)
#define FS_MMC_CMD_FLAG_STOP_TRANS        (1uL << 5)
#define FS_MMC_CMD_FLAG_WRITE_BURST_REPEAT (1uL << 6)
#define FS_MMC_CMD_FLAG_USE_MMC8MODE     (1uL << 7)
#define FS_MMC_CMD_FLAG_NO_CRC_CHECK     (1uL << 8)
#define FS_MMC_CMD_FLAG_WRITE_BURST_FILL (1uL << 9)
#define FS_MMC_CMD_FLAG_SWITCH_VOLTAGE   (1uL << 10)
```

Symbols

Definition	Description
<code>FS_MMC_CMD_FLAG_DATA-TRANSFER</code>	Command that exchanges data with the card.
<code>FS_MM-C_CMD_FLAG_WRITE-TRANSFER</code>	Command that sends data to card. Implies <code>FS_MM-C_CMD_FLAG_DATATRANSFER</code> .
<code>FS_MMC_CMD_FLAG_SET-BUSY</code>	Command that expects an R1b command.
<code>FS_MM-C_CMD_FLAG_INITIALIZE</code>	Specifies that the initialization delay has to be performed. According to SD specification this is the maximum of 1 millisecond, 74 clock cycles and supply ramp up time.
<code>FS_MM-C_CMD_FLAG_USE_SD4MODE</code>	Command that transfers the data via 4 data lines.
<code>FS_MMC_CMD_FLAG_S-STOP_TRANS</code>	Command that stops a data transfer (typically CMD12)
<code>FS_MM-C_CMD_FLAG_WRITE_BURST_REPEAT</code>	Specifies that the same sector data is written to consecutive sector indexes.
<code>FS_MM-C_CMD_FLAG_USE_MM-C8MODE</code>	Command that transfers the data via 8 data lines (MMC only).
<code>FS_MM-C_CMD_FLAG_NO_CRC_CHECK</code>	CRC verification has to be disabled for the command. Typically used with the MMC bus test commands.
<code>FS_MM-C_CMD_FLAG_WRITE_BURST_FILL</code>	Specifies that the 32-bit value is used to fill the contents of consecutive sector indexes.
<code>FS_MM-C_CMD_FLAG_SWITCH_VOLTAGE</code>	Specifies that the the signaling of the I/O lines has to be changed to 1.8 V

6.5.4.3.28 Card mode clock flags

Description

Additional options for the clock generation.

Definition

```
#define FS_MMC_CLK_FLAG_DDR_MODE          (1uL << 0)
#define FS_MMC_CLK_FLAG_STROBE_MODE     (1uL << 1)
#define FS_MMC_CLK_FLAG_ENHANCED_STROBE (1uL << 2)
```

Symbols

Definition	Description
FS_MMC_CLK_FLAG_DDR_MODE	Specifies that the data is exchanged on both clock edges.
FS_MMC_CLK_FLAG_STROBE_MODE	Specifies that the received data is sampled using a strobe signal generated by the storage device.
FS_MMC_CLK_FLAG_ENHANCED_STROBE	Specifies that the received response and data are sampled using a strobe signal generated by the storage device.

Additional information

The [FS_MMC_CLK_FLAG_STROBE_MODE](#) and [FS_MMC_CLK_FLAG_ENHANCED_STROBE](#) flags are used to specify how to sample the data coming from an eMMC device in HS400 access mode. If [FS_MMC_CLK_FLAG_STROBE_MODE](#) is set and [FS_MMC_CLK_FLAG_ENHANCED_STROBE](#) and cleared then the received data is sampled using the strobe signal while the command response using the clock supplied to eMMC device. If [FS_MMC_CLK_FLAG_STROBE_MODE](#) and [FS_MMC_CLK_FLAG_ENHANCED_STROBE](#) are both set then the received data as well as the command response are sampled using the strobe signal.

6.5.4.3.29 Card mode error codes

Description

Values that indicate the result of an operation.

Definition

```
#define FS_MMC_CARD_NO_ERROR           0
#define FS_MMC_CARD_RESPONSE_TIMEOUT  1
#define FS_MMC_CARD_RESPONSE_CRC_ERROR 2
#define FS_MMC_CARD_READ_TIMEOUT      3
#define FS_MMC_CARD_READ_CRC_ERROR    4
#define FS_MMC_CARD_WRITE_CRC_ERROR   5
#define FS_MMC_CARD_RESPONSE_GENERIC_ERROR 6
#define FS_MMC_CARD_READ_GENERIC_ERROR 7
#define FS_MMC_CARD_WRITE_GENERIC_ERROR 8
#define FS_MMC_CARD_TUNING_ERROR      9
#define FS_MMC_CARD_VOLTAGE_SWITCH_ERROR 10
```

Symbols

Definition	Description
FS_MMC_CARD_NO_ERROR	Success.
FS_MM- C_CARD_RESPONSE_TIME- OUT	No response received.
FS_MM- C_CARD_RESPONSE_CR- C_ERROR	CRC error in response detected.
FS_MM- C_CARD_READ_TIMEOUT	No data received.
FS_MMC_CARD_READ_CR- C_ERROR	CRC error in received data detected.
FS_MMC_CARD_WRITE_CR- C_ERROR	Card detected an CRC error in the received data.
FS_MM- C_CARD_RESPONSE_GEN- ERIC_ERROR	Start bit, end bit or command index error.
FS_MMC_CARD_READ_GEN- ERIC_ERROR	An error occurred during while receiving data from card.
FS_MM- C_CARD_WRITE_GEN- ERIC_ERROR	An error occurred during while sending data to card.
FS_MM- C_CARD_TUNING_ERROR	An error occurred during the tuning procedure.
FS_MMC_CARD_VOLT- AGE_SWITCH_ERROR	An error occurred during the voltage switch procedure.

6.5.4.3.30 Card mode response formats

Description

Response types returned by different commands.

Definition

```
#define FS_MMC_RESPONSE_FORMAT_NONE    0
#define FS_MMC_RESPONSE_FORMAT_R1    1
#define FS_MMC_RESPONSE_FORMAT_R2    2
#define FS_MMC_RESPONSE_FORMAT_R3    3
#define FS_MMC_RESPONSE_FORMAT_R6    FS_MMC_RESPONSE_FORMAT_R1
#define FS_MMC_RESPONSE_FORMAT_R7    FS_MMC_RESPONSE_FORMAT_R1
```

Symbols

Definition	Description
FS_MMC_RESPONSE_FORMAT_NONE	No response expected.
FS_MMC_RESPONSE_FORMAT_R1	Card status (48-bit large)
FS_MMC_RESPONSE_FORMAT_R2	CID or CSD register (128-bit large)
FS_MMC_RESPONSE_FORMAT_R3	OCR register (48-bit large)
FS_MMC_RESPONSE_FORMAT_R6	Published RCA response (48-bit large)
FS_MMC_RESPONSE_FORMAT_R7	Card interface condition (48-bit large)

6.5.4.3.31 Sample implementation

The following sample implementation uses the SD host controller of an NXP K66 MCU to interface with an SD card. This NOR hardware layer was tested on the SGGER emPower board (<https://www.segger.com/evaluate-our-software/segger/empower/>)

```

/*****
*                               (c) SEGGER Microcontroller GmbH                               *
*                               The Embedded Experts                                       *
*                               www.segger.com                                             *
*****/

----- END-OF-HEADER -----

File      : FS_MMC_HW_CM_K66_SEGGER_emPower.c
Purpose  : SD/MMC (card mode) hardware layer for Freescale Kinetis K66
Literature:
  [1] UM06001 emPower Evaluation and prototyping platform for SEGGER software User Guide &
  Reference Manual
  [2] K66P144M180SF5RMV2 K66 Sub-Family Reference Manual
  [3] SD Specifications Part 1 Physical Layer Simplified Specification Version 2.00
*/

/*****
*
*       #include section
*
*****/
#include "FS.h"

/*****
*
*       Defines, configurable
*
*****/
#ifndef FS_MMC_HW_CM_USE_DMA
#define FS_MMC_HW_CM_USE_DMA          1           // Turns the DMA support on and off
#endif

#ifndef FS_MMC_HW_CM_PERIPH_CLOCK
#define FS_MMC_HW_CM_PERIPH_CLOCK     168000000uL // Peripheral clock speed in Hz
#endif

#ifndef FS_MMC_HW_CM_MAX_SPEED
#define FS_MMC_HW_CM_MAX_SPEED        50000
// Limits the maximum communication speed to this value (kHz)
#endif

#ifndef FS_MMC_HW_CM_NUM_DMA_DESC
#define FS_MMC_HW_CM_NUM_DMA_DESC     32
// Number of DMA descriptors to allocate
#endif

#ifndef FS_MMC_HW_CM_POWER_GOOD_DELAY
#define FS_MMC_HW_CM_POWER_GOOD_DELAY 1000
// Number of milliseconds to wait for the power to stabilize.
#endif

#ifndef FS_MMC_HW_CM_USE_OS
#define FS_MMC_HW_CM_USE_OS           0
// Enables / disables the event-driven operation.
// 0 - OS support disabled.
// 1
- OS support enabled using OS event of emFile.
// 2
- OS support enabled using OS events of this HW layer.
#endif

/*****
*
*       #include section, conditional
*
*****/

```

```

*/
#if FS_MMC_HW_CM_USE_OS
#include "FS_OS.h"
#include "RTOS.h"
#include "MK66F18.h"
#endif // FS_MMC_HW_CM_USE_OS

/*****
*
*   Defines, fixed
*
*****/

#if (FS_MMC_HW_CM_USE_OS == 0)

/*****
*
*   System integration module
*/
#define SIM_BASE_ADDR          0x40047000
#define SIM_SCGC3              (*(volatile U32*)(SIM_BASE_ADDR + 0x1030))
// System Clock Gating Control Register 3
#define SIM_SCGC5              (*(volatile U32*)(SIM_BASE_ADDR + 0x1038))
// System Clock Gating Control Register 5

/*****
*
*   PORT E
*/
#define PORTE_BASE_ADDR        0x4004D000
#define PORTE_PCR0             (*(volatile U32*)(PORTE_BASE_ADDR + 0x00))
// Pin control register 0
#define PORTE_PCR1             (*(volatile U32*)(PORTE_BASE_ADDR + 0x04))
// Pin control register 1
#define PORTE_PCR2             (*(volatile U32*)(PORTE_BASE_ADDR + 0x08))
// Pin control register 2
#define PORTE_PCR3             (*(volatile U32*)(PORTE_BASE_ADDR + 0x0C))
// Pin control register 3
#define PORTE_PCR4             (*(volatile U32*)(PORTE_BASE_ADDR + 0x10))
// Pin control register 4
#define PORTE_PCR5             (*(volatile U32*)(PORTE_BASE_ADDR + 0x14))
// Pin control register 5
#define PORTE_PCR6             (*(volatile U32*)(PORTE_BASE_ADDR + 0x18))
// Pin control register 5
#define PORTE_PCR27            (*(volatile U32*)(PORTE_BASE_ADDR + 0x6C))
// Pin control register 27
#define PORTE_DFER             (*(volatile U32*)(PORTE_BASE_ADDR + 0xC0))
// Digital filter enable register

/*****
*
*   GPIO E
*/
#define GPIOE_BASE             0x400FF000
#define GPIOE_PDOR             (*(volatile U32*)(GPIOE_BASE + 0x100))
// Port Data Output Register
#define GPIOE_PDIR             (*(volatile U32*)(GPIOE_BASE + 0x110))
// Port Data Input Register
#define GPIOE_PDDR             (*(volatile U32*)(GPIOE_BASE + 0x114))
// Port Data Direction Register

/*****
*
*   SDHC
*/
#define SDHC_BASE              0x400B1000
#define SDHC_BLKATTR           (*(volatile U32*)(SDHC_BASE + 0x04))
// Block Attributes Register
#define SDHC_CMDARG            (*(volatile U32*)(SDHC_BASE + 0x08))
// Command Argument Register
#define SDHC_XFERTYP           (*(volatile U32*)(SDHC_BASE + 0x0C))
// Transfer Type Register
#define SDHC_CMDRSP0           (*(volatile U32*)(SDHC_BASE + 0x10)) // Command Response
0

```

```

#define SDHC_DATPORT      (*(volatile U32*)(SDHC_BASE + 0x20))
    // Buffer Data Port Register
#define SDHC_PRSTAT      (*(volatile U32*)(SDHC_BASE + 0x24))
    // Present State Register
#define SDHC_PROCTL      (*(volatile U32*)(SDHC_BASE + 0x28))
    // Protocol Control Register
#define SDHC_SYSCTL      (*(volatile U32*)(SDHC_BASE + 0x2C))
    // System Control Register
#define SDHC_IRQSTAT     (*(volatile U32*)(SDHC_BASE + 0x30))
    // Interrupt Status Register
#define SDHC_IRQSTATEN   (*(volatile U32*)(SDHC_BASE + 0x34))
    // Interrupt Status Enable Register
#define SDHC_IRQSIGEN    (*(volatile U32*)(SDHC_BASE + 0x38))
    // Interrupt Signal Enable Register
#define SDHC_WML         (*(volatile U32*)(SDHC_BASE + 0x44))
    // Watermark Level Register
#define SDHC_ADSADDR     (*(volatile U32*)(SDHC_BASE + 0x58))
    // ADMA System Address Register
#define SDHC_VENDOR      (*(volatile U32*)(SDHC_BASE + 0xC0))
    // Vendor Specific Register

/*****
*
*      MPU
*/
#define MPU_BASE          0x4000D000
#define MPU_RGDAAC0      (*(volatile U32*)(MPU_BASE + 0x800))
    // Region Descriptor Alternate Access Control 0

#else

/*****
*
*      Port E
*/
#define PORTE_BASE_ADDR  0x4004D000uL
#define PORTE_DFER       (*(volatile U32 *) (PORTE_BASE_ADDR + 0xC0))
    // Digital filter enable register

#endif // (FS_MMC_HW_CM_USE_OS == 0)

/*****
*
*      Pin assignments of signals
*/
#define SD_CMD_BIT        3 // Command      (GPIO E)
#define SD_CLK_BIT       2 // Clock      (GPIO E)
#define SD_D0_BIT        1 // Data 0     (GPIO E)
#define SD_D1_BIT        0 // Data 1     (GPIO E)
#define SD_D2_BIT        5 // Data 2     (GPIO E)
#define SD_D3_BIT        4 // Data 3     (GPIO E)
#define SD_CD_BIT        6 // Card detect (GPIO E)

/*****
*
*      Port control register bits
*/
#define PCR_MUX_BIT      8 // Alternate port setting
#define PCR_MUX_GPIO     1 // Controlled directly by the HW layer
#define PCR_MUX_SDHC     4 // Controlled by SDHC
#define PCR_DSE_BIT      6 // Driver strength enable
#define PCR_PE_BIT       1 // Pull enable
#define PCR_PS_BIT       0 // Pull-up enable

/*****
*
*      Clock enable bits
*/
#define SCGC3_SDHC_BIT   17 // SDHC
#define SCGC5_PORTE_BIT  13 // GPIO E

/*****
*
*      SDHC interrupt request bits
*/
#define IRQSTAT_CC_BIT   0 // Command complete

```

```

#define IRQSTAT_TC_BIT          1 // Transfer complete
#define IRQSTAT_DINT_BIT       3 // DMA interrupt
#define IRQSTAT_BWR_BIT        4 // Buffer write ready
#define IRQSTAT_BRR_BIT        5 // Buffer read ready
#define IRQSTAT_CTOE_BIT       16 // Command timeout error
#define IRQSTAT_CCE_BIT        17 // Command CRC error
#define IRQSTAT_CEBE_BIT       18 // Command end bit error
#define IRQSTAT_CIE_BIT        19 // Command index error
#define IRQSTAT_DTOE_BIT       20 // Data timeout error
#define IRQSTAT_DCE_BIT        21 // Data CRC error
#define IRQSTAT_DEBE_BIT       22 // Data end bit error
#define IRQSTAT_DMAE_BIT       28 // DMA error

/*****
 *
 *      SDHC present status bits
 */
#define PRSSTAT_CIHB_BIT        0 // Command inhibit (CMD)
#define PRSSTAT_CDIHB_BIT      1 // Command inhibit (DAT)
#define PRSSTAT_SDSTB_BIT      3 // Set to 1 if the clock is stable
#define PRSSTAT_SDOFF_BIT      7
#define PRSSTAT_BWEN_BIT       10
#define PRSSTAT_DLSTL_DAT0_BIT 24

/*****
 *
 *      SDHC system control bits
 */
#define SYSCTL_IPGEN_BIT        0
#define SYSCTL_HCKEN_BIT       1
#define SYSCTL_PEREN_BIT       2
#define SYSCTL_SDCLKEN_BIT     3
#define SYSCTL_DVS_BIT         4
#define SYSCTL_DVS_MASK        0xFuL
#define SYSCTL_DVS_MAX         (SYSCTL_DVS_MASK + 1)
#define SYSCTL_SDCLKFS_BIT     8
#define SYSCTL_SDCLKFS_MASK    0xFFuL
#define SYSCTL_DTOCV_BIT      16
#define SYSCTL_DTOCV_MASK     0xFuL
#define SYSCTL_DTOCV_MAX      (SYSCTL_DTOCV_MASK - 1)
#define SYSCTL_RSTA_BIT        24
#define SYSCTL_RSTC_BIT        25
#define SYSCTL_RSTD_BIT        26
#define SYSCTL_INITA_BIT       27

/*****
 *
 *      SDHC transfer type bits
 */
#define XFERTYP_DMAEN_BIT      0 // DMA enable
#define XFERTYP_BCEN_BIT       1
#define XFERTYP_DTDSEL_BIT     4
#define XFERTYP_MSBSEL_BIT     5
#define XFERTYP_RSPTYP_BIT     16
#define XFERTYP_RSPTYP_NONE    0uL
#define XFERTYP_RSPTYP_136BIT  1uL
#define XFERTYP_RSPTYP_48BIT   2uL
#define XFERTYP_RSPTYP_48BIT_BUSY 3uL
#define XFERTYP_CCEN_BIT       19
#define XFERTYP_CICEN_BIT      20
#define XFERTYP_DPSEL_BIT      21
#define XFERTYP_CMDIDX_BIT     24
#define XFERTYP_CMDIDX_MASK    0x3FuL

/*****
 *
 *      SDHC protocol control bits
 */
#define PROCTL_DTW_BIT         1
#define PROCTL_DTW_MASK        0x3uL
#define PROCTL_DTW_4BIT       0x1uL
#define PROCTL_EMODE_BIT      4
#define PROCTL_EMODE_LE       2uL
#define PROCTL_DMAS_BIT       8
#define PROCTL_DMAS_MASK      0x3uL
#define PROCTL_DMAS_DMA2      2uL

```

```

/*****
 *
 *      SDHC block attributes bits
 */
#define BLKATTR_BLKCNT_BIT      16

/*****
 *
 *      SDHC Watermark level
 */
#define WML_RDWML_BIT          0
#define WML_RDWML_MASK        0xFFuL
#define WML_WRWML_BIT          16
#define WML_WRWML_MASK        0xFFuL

/*****
 *
 *      DMA attributes
 */
#define DMA_ATTR_VALID_BIT     0
#define DMA_ATTR_END_BIT      1
#define DMA_ATTR_INT_BIT      2
#define DMA_ATTR_ACT_BIT      4
#define DMA_ATTR_ACT_TRAN     2uL

/*****
 *
 *      MPU region descriptor bits
 */
#define RGD_M5RE_BIT          27
#define RGD_M5WE_BIT          26

/*****
 *
 *      Number of sectors to transfer at once
 */
#define MAX_BLOCK_SIZE        512
#define MAX_DMA_LEN           65532

#if FS_MMC_HW_CM_USE_DMA
    #define NUM_BLOCKS_AT_ONCE
        ((FS_MMC_HW_CM_NUM_DMA_DESC * MAX_DMA_LEN) / MAX_BLOCK_SIZE)
#else
    #define NUM_BLOCKS_AT_ONCE    65535
#endif // FS_MMC_HW_CM_USE_DMA

#if FS_MMC_HW_CM_USE_DMA
    #define NUM_BLOCKS_AT_ONCE_REPEAT_SAME    FS_MMC_HW_CM_NUM_DMA_DESC
#else
    #define NUM_BLOCKS_AT_ONCE_REPEAT_SAME    65535
#endif

/*****
 *
 *      Timeouts and delays
 */
#define CYCLES_PER_MS          2100
#define WAIT_TIMEOUT_MS        1000
#define WAIT_TIMEOUT_CYCLES    (WAIT_TIMEOUT_MS * CYCLES_PER_MS)
#define SDHC_IRQ_PRIO          15
#if FS_MMC_HW_CM_USE_DMA
    #define STAT_MASK            ((1uL << IRQSTAT_CC_BIT) | \
        (1uL << IRQSTAT_TC_BIT) | \
        (1uL << IRQSTAT_CTOE_BIT) | \
        (1uL << IRQSTAT_CCE_BIT) | \
        (1uL << IRQSTAT_CEBE_BIT) | \
        (1uL << IRQSTAT_CIE_BIT) | \
        (1uL << IRQSTAT_DTOE_BIT) | \
        (1uL << IRQSTAT_DCE_BIT) | \
        (1uL << IRQSTAT_DEBE_BIT) | \
        (1uL << IRQSTAT_DINT_BIT))
#else
    #define STAT_MASK            ((1uL << IRQSTAT_CC_BIT) | \
        (1uL << IRQSTAT_TC_BIT) | \
        (1uL << IRQSTAT_BWR_BIT) | \

```

```

        (1uL << IRQSTAT_BRR_BIT) | \
        (1uL << IRQSTAT_CTOE_BIT) | \
        (1uL << IRQSTAT_CCE_BIT) | \
        (1uL << IRQSTAT_CEBE_BIT) | \
        (1uL << IRQSTAT_CIE_BIT) | \
        (1uL << IRQSTAT_DTOE_BIT) | \
        (1uL << IRQSTAT_DCE_BIT) | \
        (1uL << IRQSTAT_DEBE_BIT))

#endif

/*****
 *
 *      Local data types
 *
 *****/

#if FS_MMC_HW_CM_USE_DMA

/*****
 *
 *      DMA_DESC
 *
 *      Description
 *      Memory layout of a ADMA2 descriptor
 */
typedef struct {
    U16 Attr;          // Descriptor attributes
    U16 NumBytes;     // Number of bytes to transfer
    U32 Addr;         // Destination/source memory address (32-bit aligned)
} DMA_DESC;

#endif

/*****
 *
 *      Static data
 *
 *****/

static U16      _BlockSize; // Size of the block to transfer as set by the upper layer
static U16      _NumBlocks; // Number of blocks to transfer as set by the upper layer
static U8       _RepeatSame; // Set to
    1 if the same data has to be written to consecutive block indexes.
#if FS_MMC_HW_CM_USE_DMA
    static DMA_DESC _adMADESC[FS_MMC_HW_CM_NUM_DMA_DESC]; // List of DMA descriptors
    static void * _pData;
    // Destination/source buffer for the DMA transfers
#endif // FS_MMC_HW_CM_USE_DMA
#if (FS_MMC_HW_CM_USE_OS == 2)
    static U8      _IsEventInitiated = 0;
    static OS_EVENT _Event;
#endif // FS_MMC_HW_CM_USE_OS == 2

/*****
 *
 *      Static code
 *
 *****/

#if FS_MMC_HW_CM_USE_OS

/*****
 *
 *      _WaitForEvent
 *
 *      Function description
 *      Waits for the interrupt to wake up the task.
 *
 *      Parameters
 *      Timeout      Maximum time to wait for the event in milliseconds.
 *
 *      Return values
 *      ==0          OK, event signaled.
 *      !=0          An error occurred.
 *****/

```



```

*/
static int _WaitForEvent(U32 TimeOut) {
    int r;

    SDHC_IRQSIGEN |= STAT_MASK;           // Enable interrupts.
#ifdef FS_MMC_HW_CM_USE_OS == 2
    r = OS_EVENT_WaitTimed(&_Event, TimeOut);
#else
    r = FS_OS_Wait(TimeOut);
#endif
    if (r != 0) {
        SDHC_IRQSIGEN &= ~STAT_MASK;     // Disable interrupts.
    }
    return r;
}

#endif // FS_MMC_HW_CM_USE_OS

/*****
*
*      _WaitForResponse
*
* Function description
*   Waits for a command response to arrive.
*
* Return values
*   FS_MMC_CARD_NO_ERROR           Success
*   FS_MMC_CARD_RESPONSE_CRC_ERROR CRC error in response
*   FS_MMC_CARD_RESPONSE_TIMEOUT  No response received
*   FS_MMC_CARD_RESPONSE_GENERIC_ERROR Any other error
*/
static int _WaitForResponse(void) {
    U32 Status;
    U32 TimeOut;
    int r;

    //
    // Wait for command to finish
    //
    TimeOut = WAIT_TIMEOUT_CYCLES;
    for (;;) {
        Status = SDHC_IRQSTAT;
        if ((Status & (1uL << IRQSTAT_CTOE_BIT)) != 0u) {
            r = FS_MMC_CARD_RESPONSE_TIMEOUT; // Error, no response received.
            break;
        }
        if ((Status & (1uL << IRQSTAT_CCE_BIT)) != 0u) {
            r = FS_MMC_CARD_RESPONSE_CRC_ERROR; // Error, CRC error detected in response.
            break;
        }
        if ((Status & (1uL << IRQSTAT_CEBE_BIT)) != 0u) {
            r = FS_MMC_CARD_RESPONSE_GENERIC_ERROR; // Error, end bit of response is 0.
            break;
        }
        if ((Status & (1uL << IRQSTAT_CIE_BIT)) != 0u) {
            r = FS_MMC_CARD_RESPONSE_GENERIC_ERROR; // Error, command index do not match.
            break;
        }
    }
#ifdef FS_MMC_HW_CM_USE_DMA
    if ((Status & (1uL << IRQSTAT_DMAE_BIT)) != 0u) {
        r = FS_MMC_CARD_RESPONSE_GENERIC_ERROR; // Error, DMA failure.
        break;
    }
#endif // FS_MMC_HW_CM_USE_DMA
    if ((Status & (1uL << IRQSTAT_CC_BIT)) != 0u) {
        r = FS_MMC_CARD_NO_ERROR; // OK, valid response received.
        break;
    }
}
#ifdef FS_MMC_HW_CM_USE_OS
    r = _WaitForEvent(WAIT_TIMEOUT_MS);
    if (r != 0) {
        r = FS_MMC_CARD_RESPONSE_TIMEOUT; // Error, no response received.
        break;
    }
#endif // FS_MMC_HW_CM_USE_OS
    if (TimeOut-- == 0u) {

```

```

        r = FS_MMC_CARD_RESPONSE_TIMEOUT;           // Error, no response received.
        break;
    }
}
return r;
}

#if (FS_MMC_HW_CM_USE_DMA == 0)

/*****
 *
 *      _WaitForRxReady
 *
 *      Function description
 *      Waits until new data is received. The function returns in case of a receiving error.
 *
 *      Return values
 *      FS_MMC_CARD_NO_ERROR           Success
 *      FS_MMC_CARD_READ_CRC_ERROR     CRC error in received data
 *      FS_MMC_CARD_READ_TIMEOUT      No data received
 *      FS_MMC_CARD_READ_GENERIC_ERROR Any other error
 *
 *      Additional information
 */
static int _WaitForRxReady(void) {
    U32 Status;
    U32 TimeOut;
    int r;

    TimeOut = WAIT_TIMEOUT_CYCLES;
    for (;;) {
        Status = SDHC_IRQSTAT;
        if ((Status & (1uL << IRQSTAT_DEBE_BIT)) != 0u) {
            r = FS_MMC_CARD_READ_GENERIC_ERROR;           // Error, 0 detected on the end bit.
            break;
        }
        if ((Status & (1uL << IRQSTAT_DCE_BIT)) != 0u) {
            r = FS_MMC_CARD_READ_CRC_ERROR;               // Error, CRC check failed.
            break;
        }
        if ((Status & (1uL << IRQSTAT_DTOE_BIT)) != 0u) {
            r = FS_MMC_CARD_READ_TIMEOUT;                 // Error, data timeout.
            break;
        }
        if ((Status & (1uL << IRQSTAT_BRR_BIT)) != 0u) {
            r = FS_MMC_CARD_NO_ERROR;                     // OK, data can be read from queue.
            break;
        }
    }
#if FS_MMC_HW_CM_USE_OS
    r = _WaitForEvent(WAIT_TIMEOUT_MS);
    if (r != 0) {
        r = FS_MMC_CARD_RESPONSE_TIMEOUT;               // Error, no response received.
        break;
    }
#endif // FS_MMC_HW_CM_USE_OS
    if (TimeOut-- == 0u) {
        r = FS_MMC_CARD_READ_TIMEOUT;                   // Error, data timeout.
        break;
    }
}
return r;
}

/*****
 *
 *      _WaitForTxReady
 *
 *      Function description
 *      Waits until the transmitter is ready to send new data.
 *      The function returns in case of an underrun condition.
 *      This can happen when we are not able to deliver the data fast enough.
 *
 *      Return values
 *      FS_MMC_CARD_NO_ERROR           Success
 *      FS_MMC_CARD_WRITE_GENERIC_ERROR Any other error
 */

```

```

static int _WaitForTxReady(void) {
    U32 Status;
    U32 TimeOut;
    int r;

    TimeOut = WAIT_TIMEOUT_CYCLES;
    for (;;) {
        Status = SDHC_IRQSTAT;
        if ((Status & (1uL << IRQSTAT_DTOE_BIT)) != 0u) {
            r = FS_MMC_CARD_WRITE_GENERIC_ERROR;          // Error, data timeout.
            break;
        }
        if ((Status & (1uL << IRQSTAT_DCE_BIT)) != 0u) {
            r = FS_MMC_CARD_WRITE_CRC_ERROR;             // Error, CRC check failed.
            break;
        }
        if ((Status & (1uL << IRQSTAT_BWR_BIT)) != 0u) {
            r = FS_MMC_CARD_NO_ERROR;                   // OK, data can be written to queue.
            break;
        }
#ifdef FS_MMC_HW_CM_USE_OS
        r = _WaitForEvent(WAIT_TIMEOUT_MS);
        if (r != 0) {
            r = FS_MMC_CARD_RESPONSE_TIMEOUT;          // Error, no response received.
            break;
        }
#endif // FS_MMC_HW_CM_USE_OS
        if (TimeOut-- == 0u) {
            r = FS_MMC_CARD_WRITE_GENERIC_ERROR;          // Error, data timeout.
            break;
        }
    }
    return r;
}
#endif // FS_MMC_HW_CM_USE_DMA == 0

/*****
 *
 *      _WaitForCmdReady
 *
 * Function description
 *      Waits for the last command to finish.
 */
static void _WaitForCmdReady(void) {
    U32 Status;
    U32 TimeOut;

    TimeOut = WAIT_TIMEOUT_CYCLES;
    for (;;) {
        Status = SDHC_PRSTAT;
        if ((Status & (1uL << PRSSTAT_CIHB_BIT)) == 0u) {
            if ((Status & (1uL << PRSSTAT_CDIHB_BIT)) == 0u) {
                if ((Status & (1uL << PRSSTAT_DLSSL_DAT0_BIT)) != 0u) {
                    break;
                }
            }
        }
        if (TimeOut-- == 0u) {
            break;
        }
    }
}

/*****
 *
 *      _Delaylms
 *
 * Function description
 *      Busy loops for about 1 millisecond.
 */
static void _Delaylms(void) {
    volatile int i;

    for (i = 0; i < CYCLES_PER_MS; ++i) {
        ;
    }
}

```

```

}

/*****
 *
 *      _Reset
 *
 *      Function description
 *      Resets the command and data state machines. Typ. called in case of an error.
 */
static void _Reset(void) {
    //
    // Reset command path.
    //
    SDHC_SYSCTL |= 1uL << SYSCTL_RSTC_BIT;
    SDHC_SYSCTL &= ~(1uL << SYSCTL_RSTC_BIT);
    //
    // Reset data path.
    //
    SDHC_SYSCTL |= 1uL << SYSCTL_RSTD_BIT;
    SDHC_SYSCTL &= ~(1uL << SYSCTL_RSTD_BIT);
}

/*****
 *
 *      _SetWMLRead
 *
 *      Function description
 *      Sets the watermark level for read operations.
 */
static void _SetWMLRead(U32 NumBytes) {
    U32 NumWords;

    NumWords = NumBytes >> 2;
    NumWords /= 3;
    if (NumWords == 0) {
        NumWords = 1;
    }
    if (NumWords > WML_RDWML_MASK) {
        NumWords = WML_RDWML_MASK;
    }
    SDHC_WML &= ~(WML_RDWML_MASK << WML_RDWML_BIT);
    SDHC_WML |= NumWords << WML_RDWML_BIT;
}

/*****
 *
 *      _SetWMLWrite
 *
 *      Function description
 *      Sets the watermark level for write operations.
 */
static void _SetWMLWrite(U32 NumBytes) {
    U32 NumWords;

    NumWords = NumBytes >> 2;
    NumWords = (NumWords << 1) / 3;
    if (NumWords == 0) {
        NumWords = 1;
    }
    if (NumWords > WML_WRWML_MASK) {
        NumWords = WML_WRWML_MASK;
    }
    SDHC_WML &= ~(WML_WRWML_MASK << WML_WRWML_BIT);
    SDHC_WML |= NumWords << WML_WRWML_BIT;
}

#if (FS_MMC_HW_CM_USE_DMA == 0)

/*****
 *
 *      _GetWMLRead
 *
 */
static U32 _GetWMLRead(void) {
    U32 NumWords;

    NumWords = (SDHC_WML >> WML_RDWML_BIT) & WML_RDWML_MASK;
}

```

```

    return NumWords;
}

/*****
 *
 *      _GetWMLWrite
 */
static U32 _GetWMLWrite(void) {
    U32 NumWords;

    NumWords = (SDHC_WML >> WML_WRWML_BIT) & WML_WRWML_MASK;
    return NumWords;
}

#endif // FS_MMC_HW_CM_USE_DMA == 0

#if FS_MMC_HW_CM_USE_DMA

/*****
 *
 *      _StartDMATransfer
 *
 * Function description
 * Starts a DMA data transfer.
 */
static void _StartDMATransfer(void) {
    U32      NumBytes;
    DMA_DESC * pDesc;
    int      i;
    U8       * pAddr;
    U32      NumBytesAtOnce;

    pDesc     = _aDMADESC;
    pAddr     = (U8 *)_pData;
    NumBytes  = _NumBlocks * _BlockSize;
    for (i = 0; i < FS_MMC_HW_CM_NUM_DMA_DESC; ++i) {
        if (_RepeatSame == 0) {
            NumBytesAtOnce = SEGGER_MIN(NumBytes, MAX_DMA_LEN);
        } else {
            NumBytesAtOnce = SEGGER_MIN(NumBytes, MAX_BLOCK_SIZE);
        }
        pDesc->Addr      = (U32)pAddr;
        pDesc->NumBytes  = NumBytesAtOnce;
        pDesc->Attr      = (DMA_ATTR_ACT_TRAN << DMA_ATTR_ACT_BIT)
            | (1uL << DMA_ATTR_VALID_BIT)
            ;
        if (_RepeatSame == 0) {
            pAddr      += NumBytesAtOnce;
        }
        NumBytes      -= NumBytesAtOnce;
        if (NumBytes == 0) {
            pDesc->Attr |= (1uL << DMA_ATTR_INT_BIT)
                | (1uL << DMA_ATTR_END_BIT)
                ;
            // Set the DMA interrupt flag at the end of transfer.
            break;
        }
        ++pDesc;
    }
    SDHC_ADSADDR = (U32)_aDMADESC;
    SDHC_PROCTL  &= ~(PROCTL_DMAS_MASK << PROCTL_DMAS_BIT);
    SDHC_PROCTL  |= (PROCTL_DMAS_DMA2 << PROCTL_DMAS_BIT);
}

/*****
 *
 *      _WaitForEndOfDMARead
 *
 * Function description
 * Waits for the end of a DMA read transfer.
 *
 * Return value
 * ==0    OK, data transferred successfully.
 * !=0    An error occurred.
 */
static int _WaitForEndOfDMARead(void) {

```

```

U32 Status;
U32 TimeOut;
int r;

TimeOut = WAIT_TIMEOUT_CYCLES;
for (;;) {
    Status = SDHC_IRQSTAT;
    if ((Status & (1uL << IRQSTAT DTOE_BIT)) != 0u) {
        r = FS_MMC_CARD_READ_TIMEOUT;           // Error, data timeout.
        break;
    }
    if ((Status & (1uL << IRQSTAT DCE_BIT)) != 0u) {
        r = FS_MMC_CARD_READ_CRC_ERROR;       // Error, CRC check failed.
        break;
    }
    if ((Status & (1uL << IRQSTAT DMAE_BIT)) != 0u) {
        r = FS_MMC_CARD_READ_GENERIC_ERROR;   // Error, DMA transfer failed.
        break;
    }
    if ((Status & (1uL << IRQSTAT DINT_BIT)) != 0u) {
        r = FS_MMC_CARD_NO_ERROR;           // OK, DMA transfer complete.
        break;
    }
}
#if FS_MMC_HW_CM_USE_OS
    r = _WaitForEvent(WAIT_TIMEOUT_MS);
    if (r != 0) {
        r = FS_MMC_CARD_READ_TIMEOUT;       // Error, no response received.
        break;
    }
#endif // FS_MMC_HW_CM_USE_OS
    if (TimeOut-- == 0u) {
        r = FS_MMC_CARD_READ_TIMEOUT;       // Error, data timeout.
        break;
    }
}
return r;
}

/*****
 *
 *      _WaitForEndOfDMAWrite
 *
 * Function description
 *      Waits for the end of a DMA write transfer.
 *
 * Return value
 *      ==0    OK, data transferred successfully.
 *      !=0    An error occurred.
 */
static int _WaitForEndOfDMAWrite(void) {
    U32 Status;
    U32 TimeOut;
    int r;

    TimeOut = WAIT_TIMEOUT_CYCLES;
    for (;;) {
        Status = SDHC_IRQSTAT;
        if ((Status & (1uL << IRQSTAT DTOE_BIT)) != 0u) {
            r = FS_MMC_CARD_WRITE_GENERIC_ERROR; // Error, data timeout.
            break;
        }
        if ((Status & (1uL << IRQSTAT DCE_BIT)) != 0u) {
            r = FS_MMC_CARD_WRITE_CRC_ERROR; // Error, CRC check failed.
            break;
        }
        if ((Status & (1uL << IRQSTAT DMAE_BIT)) != 0u) {
            r = FS_MMC_CARD_WRITE_GENERIC_ERROR; // Error, DMA transfer failed.
            break;
        }
        if ((Status & (1uL << IRQSTAT DINT_BIT)) != 0u) {
            r = FS_MMC_CARD_NO_ERROR; // OK, DMA transfer complete.
            break;
        }
    }
#if FS_MMC_HW_CM_USE_OS
    r = _WaitForEvent(WAIT_TIMEOUT_MS);
    if (r != 0) {

```

```

        r = FS_MMC_CARD_WRITE_GENERIC_ERROR;           // Error, no response received.
        break;
    }
#endif // FS_MMC_HW_CM_USE_OS
    if (TimeOut-- == 0u) {
        r = FS_MMC_CARD_WRITE_GENERIC_ERROR;           // Error, data timeout.
        break;
    }
}
return r;
}

#endif // FS_MMC_HW_CM_USE_DMA

/*****
 *
 *      Public code (via callback)
 *
 *****/

/*****
 *
 *      _HW_Init
 *
 *      Function description
 *      Initialize the SD / MMC host controller.
 *
 *      Parameters
 *      Unit      Index of the SD / MMC host controller (0-based).
 */
static void _HW_Init(U8 Unit) {
    int i;

    FS_USE_PARA(Unit);
    //
    // Enable the clock of GPIOs and of SDHC
    //
    SIM_SCGC3 |= 1uL << SCGC3_SDHC_BIT;
    SIM_SCGC5 |= 1uL << SCGC5_PORTE_BIT;
    //
    // Clock line
    //
    PORTE_PCR2 = (PCR_MUX_SDHC << PCR_MUX_BIT)
                | (1uL << PCR_PE_BIT)
                | (1uL << PCR_PS_BIT)
                | (1uL << PCR_DSE_BIT)
                ;

    //
    // Command line
    //
    PORTE_PCR3 = (PCR_MUX_SDHC << PCR_MUX_BIT)
                | (1uL << PCR_PE_BIT)
                | (1uL << PCR_PS_BIT)
                | (1uL << PCR_DSE_BIT)
                ;

    //
    // Data 0 line
    //
    PORTE_PCR1 = (PCR_MUX_SDHC << PCR_MUX_BIT)
                | (1uL << PCR_PE_BIT)
                | (1uL << PCR_PS_BIT)
                | (1uL << PCR_DSE_BIT)
                ;

    //
    // Data 1 line
    //
    PORTE_PCR0 = (PCR_MUX_SDHC << PCR_MUX_BIT)
                | (1uL << PCR_PE_BIT)
                | (1uL << PCR_PS_BIT)
                | (1uL << PCR_DSE_BIT)
                ;

    //
    // Data 2 line
    //
    PORTE_PCR5 = (PCR_MUX_SDHC << PCR_MUX_BIT)

```

```

        | (1uL      << PCR_PE_BIT)
        | (1uL      << PCR_PS_BIT)
        | (1uL      << PCR_DSE_BIT)
        ;

//
// Data 3 line
//
PORTE_PCR4 = (PCR_MUX_SDHC << PCR_MUX_BIT)
        | (1uL      << PCR_PE_BIT)
        | (1uL      << PCR_PS_BIT)
        | (1uL      << PCR_DSE_BIT)
        ;

//
// Write protect is controlled by the HW layer.
//
PORTE_PCR27 = (PCR_MUX_GPIO << PCR_MUX_BIT)
        | (1uL      << PCR_PE_BIT)
        | (1uL      << PCR_PS_BIT)
        ;

//
// Card detect is controlled by the HW layer
//
PORTE_PCR6 = (PCR_MUX_GPIO << PCR_MUX_BIT)
        | (1uL      << PCR_PE_BIT)
        | (1uL      << PCR_PS_BIT)
        ;

//
// Disable the digital filtering on all port pins assigned to SDHC.
//
PORTE_DFER &= ~((1uL << SD_CD_BIT) |
        (1uL << SD_CLK_BIT) |
        (1uL << SD_CMD_BIT) |
        (1uL << SD_D0_BIT) |
        (1uL << SD_D1_BIT) |
        (1uL << SD_D2_BIT) |
        (1uL << SD_D3_BIT));
#endif FS_MMC_HW_CM_USE_DMA
//
// Give DMA access to system memory.
//
MPU_RGDAAC0 |= (1uL << RGD_M5RE_BIT)
        | (1uL << RGD_M5WE_BIT)
        ;
#endif
#endif FS_MMC_HW_CM_USE_OS
//
// Disable the interrupt and configure the priority.
//
NVIC_DisableIRQ(SDHC_IRQn);
NVIC_SetPriority(SDHC_IRQn, SDHC_IRQ_PRIO);
#endif // FS_MMC_HW_CM_USE_OS
//
// Configure SDHC.
//
SDHC_SYSCTL = 1uL << SYSCTL_RSTA_BIT; // Reset peripheral.
SDHC_SYSCTL = 0; // Start peripheral.
SDHC_PROCTL = PROCTL_EMODE_LE << PROCTL_EMODE_BIT; // Muti-byte data is little endian.
SDHC_VENDOR = 0; // No external DMA requests.
SDHC_IRQSIGEN = 0; // Disable all the interrupts.
//
// Wait for the power to stabilize before the first access to SD card
//
for (i = 0; i < FS_MMC_HW_CM_POWER_GOOD_DELAY; ++i) {
    _Delaylms();
}
#endif FS_MMC_HW_CM_USE_OS
//
// Create the OS event and enable the interrupt.
//
#endif (FS_MMC_HW_CM_USE_OS == 2)
if (_IsEventInited == 0) {
    OS_EVENT_Create(&_Event);
    _IsEventInited = 1;
}
#endif // FS_MMC_HW_CM_USE_OS == 2
NVIC_EnableIRQ(SDHC_IRQn);

```



```

#endif // FS_MMC_HW_CM_USE_OS
}

/*****
 *
 *      _HW_Delay
 *
 * Function description
 *   Blocks the execution for the specified time.
 *
 * Parameters
 *   ms   Number of milliseconds to delay.
 */
static void _HW_Delay(int ms) {
    int i;

    for (i = 0; i < ms; ++i) {
        _Delay1ms();
    }
}

/*****
 *
 *      _HW_IsPresent
 *
 * Function description
 *   Returns the state of the media. If you do not know the state, return
 *   FS_MEDIA_STATE_UNKNOWN and the higher layer will try to figure out if
 *   a media is present.
 *
 * Parameters
 *   Unit   Index of the SD / MMC host controller (0-based).
 *
 * Return value
 *   FS_MEDIA_STATE_UNKNOWN   The state of the media is unknown
 *   FS_MEDIA_NOT_PRESENT     No card is present
 *   FS_MEDIA_IS_PRESENT      A card is present
 */
static int _HW_IsPresent(U8 Unit) {
    int r;

    FS_USE_PARA(Unit);
    r = (GPIOE_PDIR & (1uL << SD_CD_BIT)) ? FS_MEDIA_IS_PRESENT : FS_MEDIA_NOT_PRESENT;
    return r;
}

/*****
 *
 *      _HW_IsWriteProtected
 *
 * Function description
 *   Returns whether card is write protected or not.
 *
 * Parameters
 *   Unit   Index of the SD / MMC host controller (0-based).
 *
 * Notes
 *   (1) The emPower V2 board does not have an WP detect pin.
 */
static int _HW_IsWriteProtected(U8 Unit) {
    FS_USE_PARA(Unit);
    return 0; // Note 1
}

/*****
 *
 *      _HW_SetMaxSpeed
 *
 * Function description
 *   Sets the frequency of the MMC/SD card controller.
 *   The frequency is given in kHz.
 *
 * Parameters
 *   Unit   Index of the SD / MMC host controller (0-based).
 *
 * Additional information

```

```

*   This function is called two times:
*   1. During card initialization
*       Initialize the frequency to not more than 400kHz.
*
*   2. After card initialization
*       The CSD register of card is read and the max frequency
*       the card can operate is determined.
*       [In most cases: MMC cards 20MHz, SD cards 25MHz]
*/
static U16 _HW_SetMaxSpeed(U8 Unit, U16 Freq) {
    U32 Prescaler;
    U32 Divisor;
    U32 Factor;
    U32 SDClock;

    FS_USE_PARA(Unit);
    //
    // Limit the communication speed.
    //
    if (Freq > FS_MMC_HW_CM_MAX_SPEED) {
        Freq = FS_MMC_HW_CM_MAX_SPEED;
    }
    SDClock = Freq * 1000;           // Convert to Hz
    Factor = (FS_MMC_HW_CM_PERIPH_CLOCK + SDClock - 1) / SDClock;
    //
    // Determine the prescaler and the divisor values.
    //
    if (Factor == 0) {
        Factor = 1;
    }
    if (Factor <= SYSCTL_DVS_MAX) {
        Prescaler = 0;
        Divisor = Factor - 1;
    } else {
        Prescaler = 1;
        while (1) {
            //
            // Compensate for integer division errors. We must generate a clock frequency <= Freq.
            //
            if (Factor & 1) {
                ++Factor;
            }
            Factor >>= 1;
            if (Factor <= SYSCTL_DVS_MAX) {
                Divisor = Factor - 1;
                break;
            }
            Prescaler <<= 1;
        }
    }
    //
    // Stop the clock to be able to change its frequency.
    //
    SDHC_SYSCTL &= ~(1uL << SYSCTL_SDCLKEN_BIT);
    //
    // Set the prescaler and the divisor.
    //
    SDHC_SYSCTL &= ~((SYSCTL_SDCLKFS_MASK << SYSCTL_SDCLKFS_BIT) |
                    (SYSCTL_DVS_MASK << SYSCTL_DVS_BIT));
    SDHC_SYSCTL |= ((Prescaler & SYSCTL_SDCLKFS_MASK) << SYSCTL_SDCLKFS_BIT)
                  | ((Divisor & SYSCTL_DVS_MASK) << SYSCTL_DVS_BIT)
                  ;
    //
    // Enable the clock to SD card.
    //
    SDHC_SYSCTL |= (1uL << SYSCTL_SDCLKEN_BIT)
                  | (1uL << SYSCTL_PEREN_BIT)
                  | (1uL << SYSCTL_HCKEN_BIT)
                  | (1uL << SYSCTL_IPGEN_BIT)
                  ;
    //
    // Wait for the clock to stabilize.
    //
    while ((SDHC_PRSTAT & (1uL << PRSTAT_SDSTB_BIT)) == 0) {
        ;
    }
}

```

```

//
// Return the actual clock frequency.
//
Factor = 1;
if (Prescaler) {
    Factor *= Prescaler << 1;
}
Factor *= Divisor + 1;
Freq = FS_MMC_HW_CM_PERIPH_CLOCK / 1000 / Factor;
return Freq;
}

/*****
*
*     _HW_SetResponseTimeOut
*
* Function description
*     Sets the response time out value given in MMC/SD card cycles.
*
* Parameters
*     Unit     Index of the SD / MMC host controller (0-based).
*
* Notes
*     (1) The SD host controller has only a short and a long timeout.
*     We always set the long timeout before we send a command.
*/
static void _HW_SetResponseTimeOut(U8 Unit, U32 Value) {
    FS_USE_PARA(Unit);
    FS_USE_PARA(Value);
    //
    // Note 1
    //
}

/*****
*
*     _HW_SetReadDataTimeOut
*
* Function description
*     Sets the read data time out value given in MMC/SD card cycles.
*
* Parameters
*     Unit     Index of the SD / MMC host controller (0-based).
*/
static void _HW_SetReadDataTimeOut(U8 Unit, U32 Value) {
    FS_USE_PARA(Unit);

    if (Value > SYSCTL_DTOCV_MAX) {
        Value = SYSCTL_DTOCV_MAX;
    }
    SDHC_SYSCTL &= ~(SYSCTL_DTOCV_MASK << SYSCTL_DTOCV_BIT);
    SDHC_SYSCTL |= Value << SYSCTL_DTOCV_BIT;
}

/*****
*
*     _HW_SendCmd
*
* Function description
*     Sends a command to the card.
*
* Parameters
*     Unit         Index of the SD / MMC host controller (0-based).
*     Cmd          Command number according to [4]
*     CmdFlags     Additional information about the command to execute
*     ResponseType Type of response as defined in [4]
*     Arg          Command parameter
*/
static void _HW_SendCmd(U8 Unit, unsigned Cmd, unsigned CmdFlags, unsigned ResponseType, U32 Arg) {
    U32 RegValue;

    FS_USE_PARA(Unit);
    _WaitForCmdReady();
    _Reset();
    _RepeatSame = 0;
    if (CmdFlags & FS_MMC_CMD_FLAG_WRITE_BURST_REPEAT) {

```

```

    _RepeatSame = 1;
}
RegValue = (Cmd & XFERTYP_CMDIDX_MASK) << XFERTYP_CMDIDX_BIT; // Set the command index.
switch (ResponseType) {
//
// No response is expected
//
case FS_MMC_RESPONSE_FORMAT_NONE:
default:
    RegValue |= XFERTYP_RSPTYP_NONE << XFERTYP_RSPTYP_BIT;
    break;
//
// Short response is expected (48bit)
//
case FS_MMC_RESPONSE_FORMAT_R3:
    RegValue |= XFERTYP_RSPTYP_48BIT << XFERTYP_RSPTYP_BIT;
    break;

case FS_MMC_RESPONSE_FORMAT_R1:
    if (CmdFlags & FS_MMC_CMD_FLAG_SETBUSY) {
        RegValue |= XFERTYP_RSPTYP_48BIT_BUSY << XFERTYP_RSPTYP_BIT;
    } else {
        RegValue |= XFERTYP_RSPTYP_48BIT << XFERTYP_RSPTYP_BIT;
    }
    RegValue |= 0
                | (1uL << XFERTYP_CICEN_BIT) // Check the received command index.
                | (1uL << XFERTYP_CCCEN_BIT) // Check the CRC of response.
                ;
    break;
//
// Long response is expected (136bit)
//
case FS_MMC_RESPONSE_FORMAT_R2:
    RegValue |= (XFERTYP_RSPTYP_136BIT << XFERTYP_RSPTYP_BIT)
                | (1uL << XFERTYP_CCCEN_BIT)
// Check the CRC of response.
                ;
    break;
}
//
// If required, Setup the transfer over data lines.
//
if (CmdFlags & FS_MMC_CMD_FLAG_DATATRANSFER) {
    RegValue |= (1uL << XFERTYP_DPSEL_BIT)
                ;
    if (_NumBlocks > 1) {
        RegValue |= (1uL << XFERTYP_MSBSEL_BIT)
                    | (1uL << XFERTYP_BCEN_BIT)
                    ;
    }
    if (CmdFlags & FS_MMC_CMD_FLAG_WRITETRANSFER) {
        _SetWMLWrite(_BlockSize);
    } else {
        _SetWMLRead(_BlockSize);
        RegValue |= (1uL << XFERTYP_DTDSEL_BIT); // Read data from SD card.
    }
//
// Configure the size and the number of blocks to transfer
//
SDHC_BLKATTR = (_NumBlocks << BLKATTR_BLKCNT_BIT) | _BlockSize;
//
// Configure the number of data lines to use for the transfer.
//
SDHC_PROCTL &= ~(PROCTL_DTW_MASK << PROCTL_DTW_BIT);
if (CmdFlags & FS_MMC_CMD_FLAG_USE_SD4MODE) {
    SDHC_PROCTL |= (PROCTL_DTW_4BIT << PROCTL_DTW_BIT);
}
}
#if FS_MMC_HW_CM_USE_DMA
    RegValue |= (1uL << XFERTYP_DMAEN_BIT);
    _StartDMAtransfer();
#endif // FS_MMC_HW_CM_USE_DMA
}
//
// Enable all the status flags we handle.
//
SDHC_IRQSTATEN = STAT_MASK;

```

```

//
// This is the initialization delay defined by the SD card specification as:
// maximum of 1 msec, 74 clock cycles and supply ramp up time.
// The sequence below sends 80 clock cycles which is enough for
// the power supply of SD card to raise to Vdd min.
//
if (CmdFlags & FS_MMC_CMD_FLAG_INITIALIZE) {
    SDHC_SYSCTL |= 1uL << SYSCTL_INITA_BIT;
    while (SDHC_SYSCTL & (1uL << SYSCTL_INITA_BIT)) {
        ;
    }
}
SDHC_IRQSTAT = ~0uL; // Reset all status flags.
SDHC_CMDARG = Arg;
SDHC_XFERTYP = RegValue; // Send the command.
}

/*****
*
*     _HW_GetResponse
*
* Function description
*     Receives the responses that was sent by the card after
*     a command was sent to the card.
*
* Parameters
*     Unit      Index of the SD / MMC host controller (0-based).
*     pBuffer   User allocated buffer where the response is stored.
*     Size      Size of the buffer in bytes
*
* Return values
*     FS_MMC_CARD_NO_ERROR           Success
*     FS_MMC_CARD_RESPONSE_CRC_ERROR CRC error in response
*     FS_MMC_CARD_RESPONSE_TIMEOUT   No response received
*     FS_MMC_CARD_RESPONSE_GENERIC_ERROR Any other error
*
* Notes
*     (1) The response data has to be stored at byte offset 1 since
*         the controller does not provide the first byte of response.
*/
static int _HW_GetResponse(U8 Unit, void * pBuffer, U32 Size) {
    U8 * pData;
    volatile U32 * pReg;
    U32 NumWords;
    U32 Value;
    U32 i;
    int r;

    FS_USE_PARA(Unit);
    r = _WaitForResponse();
    if (r != FS_MMC_CARD_NO_ERROR) {
        _Reset();
        return r; // Error
    }
    //
    // The size we get from the upper driver is total response size in bytes.
    // We compute here the number of read accesses to the 32-bit register which
    // holds the response. Take into account that the first byte of the response
    // is not delivered by the hardware
    //
    NumWords = (Size - 1) / 4;
    pData = (U8 *)pBuffer;
    pReg = (volatile U32 *)&SDHC_CMDRSP0 + (NumWords - 1);
    //
    // In case of a 136 bit response SDHC does not deliver the checksum byte.
    // By not incrementing the data pointer the bytes are saved at expected positions.
    //
    if (NumWords != 4) {
        ++pData; // See note (1)
    }
    for (i = 0; i < NumWords; ++i) {
        Value = *pReg;
        *pData++ = (U8)(Value >> 24);
        *pData++ = (U8)(Value >> 16);
        *pData++ = (U8)(Value >> 8);
        *pData++ = (U8)Value;
    }
}

```

```

--pReg;
}
return FS_MMC_CARD_NO_ERROR; // OK, valid command received.
}

/*****
 *
 *      _HW_ReadData
 *
 * Function description
 * Reads data from the card using the SD / MMC host controller.
 *
 * Return values
 * FS_MMC_CARD_NO_ERROR          Success
 * FS_MMC_CARD_READ_CRC_ERROR   CRC error in received data
 * FS_MMC_CARD_READ_TIMEOUT     No data received
 * FS_MMC_CARD_READ_GENERIC_ERROR Any other error
 */
static int _HW_ReadData(U8 Unit, void * pBuffer, unsigned NumBytes, unsigned NumBlocks) {
#if FS_MMC_HW_CM_USE_DMA
    int r;

    FS_USE_PARA(Unit);
    FS_USE_PARA(pBuffer);
    FS_USE_PARA(NumBytes);
    FS_USE_PARA(NumBlocks);
    r = _WaitForEndOfDMARead();
    return r;
#else
    U32 NumWords;
    U32 * pData32;
    U32 NumWordsAtOnce;
    U32 WordsPerBlock;
    U32 WMLRead;
    int r;

    FS_USE_PARA(Unit);
    pData32 = (U32 *)pBuffer;
    WordsPerBlock = NumBytes / 4;
    WMLRead = _GetWMLRead();
    do {
        NumWords = WordsPerBlock;
        do {
            r = _WaitForRxReady();
            if (r != FS_MMC_CARD_NO_ERROR) {
                _Reset();
                return r; // Error
            }
            NumWordsAtOnce = SEGGER_MIN(NumWords, WMLRead);
            NumWords -= NumWordsAtOnce;
            do {
                *pData32++ = SDHC_DATPORT;
            } while (--NumWordsAtOnce);
            SDHC_IRQSTAT = 1uL << IRQSTAT_BRR_BIT;
            // This flag is only set by SDHC. We have to clear it here to get the next notification.
        } while (NumWords);
    } while (--NumBlocks);
    return FS_MMC_CARD_NO_ERROR; // OK, data received.
#endif
}

/*****
 *
 *      _HW_WriteData
 *
 * Function description
 * Writes the data to SD / MMC card using the SD / MMC host controller.
 *
 * Return values
 * FS_MMC_CARD_NO_ERROR          Success
 * FS_MMC_CARD_READ_TIMEOUT     No data received
 */
static int _HW_WriteData(U8 Unit, const void * pBuffer, unsigned NumBytes, unsigned NumBlocks) {
#if FS_MMC_HW_CM_USE_DMA
    int r;

```

```

FS_USE_PARA(Unit);
FS_USE_PARA(pBuffer);
FS_USE_PARA(NumBytes);
FS_USE_PARA(NumBlocks);
r = _WaitForEndOfDMAWrite();
return r;
#else
U32      NumWords;
const U32 * pData32;
int      r;
U32      NumWordsAtOnce;
U32      WordsPerBlock;
U32      WMLWrite;

FS_USE_PARA(Unit);
pData32   = (U32 *)pBuffer;
WordsPerBlock = NumBytes / 4;
WMLWrite  = _GetWMLWrite();
do {
    NumWords = WordsPerBlock;
    if (_RepeatSame) {
        pData32 = (U32 *)pBuffer;
    }
    do {
        r = _WaitForTxReady();
        if (r != FS_MMC_CARD_NO_ERROR) {
            _Reset();
            return r;                // Error
        }
        NumWordsAtOnce = SEGGER_MIN(NumWords, WMLWrite);
        NumWords      -= NumWordsAtOnce;
        do {
            SDHC_DATPORT = *pData32++;
        } while (--NumWordsAtOnce);
        SDHC_IRQSTAT = 1uL << IRQSTAT_BWR_BIT;
        // This flag is only set by SDHC. We have to clear it here to get the next notification.
    } while (NumWords);
} while (--NumBlocks);
return FS_MMC_CARD_NO_ERROR;        // OK, data sent.
#endif
}

/*****
 *
 *      _HW_SetDataPointer
 *
 * Function description
 * Tells the hardware layer where to read data from or write data to.
 * Some SD host controllers require the address of the data buffer
 * before sending the command to the card, eg. programming the DMA.
 * In most cases this function can be left empty.
 *
 * Parameters
 * Unit      Index of the SD / MMC host controller (0-based).
 * p         Data buffer.
 */
static void _HW_SetDataPointer(U8 Unit, const void * p) {
    FS_USE_PARA(Unit);
#ifdef FS_MMC_HW_CM_USE_DMA
    _pData = (void *)p;
    // Cast const away. The same buffer is used also for read operations.
#else
    FS_USE_PARA(p);
#endif
}

/*****
 *
 *      _HW_SetBlockLen
 *
 * Function description
 * Sets the block size (sector size) that has to be transferred.
 *
 * Parameters
 * Unit      Index of the SD / MMC host controller (0-based).
 */

```

```

static void _HW_SetBlockLen(U8 Unit, U16 BlockSize) {
    FS_USE_PARA(Unit);
    _BlockSize = BlockSize;
}

/*****
 *
 *      _HW_SetNumBlocks
 *
 * Function description
 *   Sets the number of blocks (sectors) to be transferred.
 *
 * Parameters
 *   Unit      Index of the SD / MMC host controller (0-based).
 */
static void _HW_SetNumBlocks(U8 Unit, U16 NumBlocks) {
    FS_USE_PARA(Unit);
    _NumBlocks = NumBlocks;
}

/*****
 *
 *      _HW_GetMaxReadBurst
 *
 * Function description
 *   Returns the number of block (sectors) that can be read at once
 *   with a single READ_MULTIPLE_SECTOR command.
 *
 * Parameters
 *   Unit      Index of the SD / MMC host controller (0-based).
 *
 * Return value
 *   Number of sectors that can be read at once.
 */
static U16 _HW_GetMaxReadBurst(U8 Unit) {
    FS_USE_PARA(Unit);
    return NUM_BLOCKS_AT_ONCE;
}

/*****
 *
 *      _HW_GetMaxWriteBurst
 *
 * Function description
 *   Returns the number of block (sectors) that can be written at once
 *   with a single WRITE_MULTIPLE_SECTOR command.
 *
 * Parameters
 *   Unit      Index of the SD / MMC host controller (0-based).
 *
 * Return value
 *   Number of sectors that can be written at once.
 */
static U16 _HW_GetMaxWriteBurst(U8 Unit) {
    FS_USE_PARA(Unit);
    return NUM_BLOCKS_AT_ONCE;
}

/*****
 *
 *      _HW_GetMaxWriteBurstRepeat
 *
 * Function description
 *   Returns the number of block (sectors) that can be written at once
 *   with a single WRITE_MULTIPLE_SECTOR command and that contain the
 *   same data.
 *
 * Parameters
 *   Unit      Index of the SD / MMC host controller (0-based).
 *
 * Return value
 *   Number of sectors that can be written at once. The function has
 *   to return 0 if the feature is not supported.
 */
static U16 _HW_GetMaxWriteBurstRepeat(U8 Unit) {
    FS_USE_PARA(Unit);

```



```

return NUM_BLOCKS_AT_ONCE_REPEAT_SAME;
}

/*****
 *
 *   Public code
 *
 *****/

#if FS_MMC_HW_CM_USE_OS

/*****
 *
 *   SDHC_IRQHandler
 */
void SDHC_IRQHandler(void);
void SDHC_IRQHandler(void) {
    OS_EnterInterrupt();
    SDHC_IRQSIGEN &= ~STAT_MASK;           // Disable interrupts.
    #if (FS_MMC_HW_CM_USE_OS == 2)
        OS_EVENT_Set(&_Event);
    #else
        FS_OS_Signal();
    #endif // FS_MMC_HW_CM_USE_OS == 2
    OS_LeaveInterrupt();
}

#endif // FS_MMC_HW_CM_USE_OS

/*****
 *
 *   FS_MMC_HW_CM_K66_SEGGER_emPower
 */
const FS_MMC_HW_TYPE_CM FS_MMC_HW_CM_K66_SEGGER_emPower = {
    _HW_Init,
    _HW_Delay,
    _HW_IsPresent,
    _HW_IsWriteProtected,
    _HW_SetMaxSpeed,
    _HW_SetResponseTimeout,
    _HW_SetReadDataTimeout,
    _HW_SendCmd,
    _HW_GetResponse,
    _HW_ReadData,
    _HW_WriteData,
    _HW_SetDataPointer,
    _HW_SetBlockLen,
    _HW_SetNumBlocks,
    _HW_GetMaxReadBurst,
    _HW_GetMaxWriteBurst,
    _HW_GetMaxWriteBurstRepeat,
    NULL,
    NULL,
    NULL,
    NULL,
    NULL,
    NULL,
    NULL,
    NULL,
    NULL,
    NULL,
};

/***** End of file *****/

```

6.5.5 Troubleshooting

If the driver test fails or if the card cannot be accessed at all, please follow the troubleshooting guidelines below.

6.5.5.1 SPI mode troubleshooting guide

First, verify the SPI configuration. The SPI data transfer has to be configured as follows:

- 8 bits per transfer.
- Most significant bit first.
- Data changes on falling edge.
- Data is sampled on rising edge.

Then verify the waveform of the SPI signals using an oscilloscope. The following reference images were taken with an oscilloscope that was set up to trigger a single time on falling edge of Chip Select (CS) signal. The color coding of the signals in these pictures is as follows:

Color	Description
RED	MOSI - Master Out Slave In (Pin 2)
PURPLE	MISO - Master In Slave Out (Pin 7)
GREEN	CLK - Clock (Pin 5)
YELLOW	CS - Chip Select (Pin 1)

To check if your implementation of the hardware layer works correct, compare your output of the relevant lines (SCLK, CS, MISO, MOSI) with the correct output which is shown in the following pictures. The output of your card should be similar. In the example, MISO has a pull-up and a pull-down of equal value. This means that the MISO signal level is at 50% (1.65V) when the output of the card is inactive. On other target hardware, the inactive level can be low (in case a pull-down is used) or high (if a pull-up is used).

The initial communication sequence consists of the following three parts:

1. Outputs 10 dummy bytes with CS disabled, MOSI = 1.
2. Sets CS low and send a 6-byte command (`GO_IDLE_STATE` command).
3. Receives two bytes, sets CS high and outputs 1 dummy byte with CS disabled, MOSI = 1.

The following picture shows the data flow of a correct initialization of an SD card.

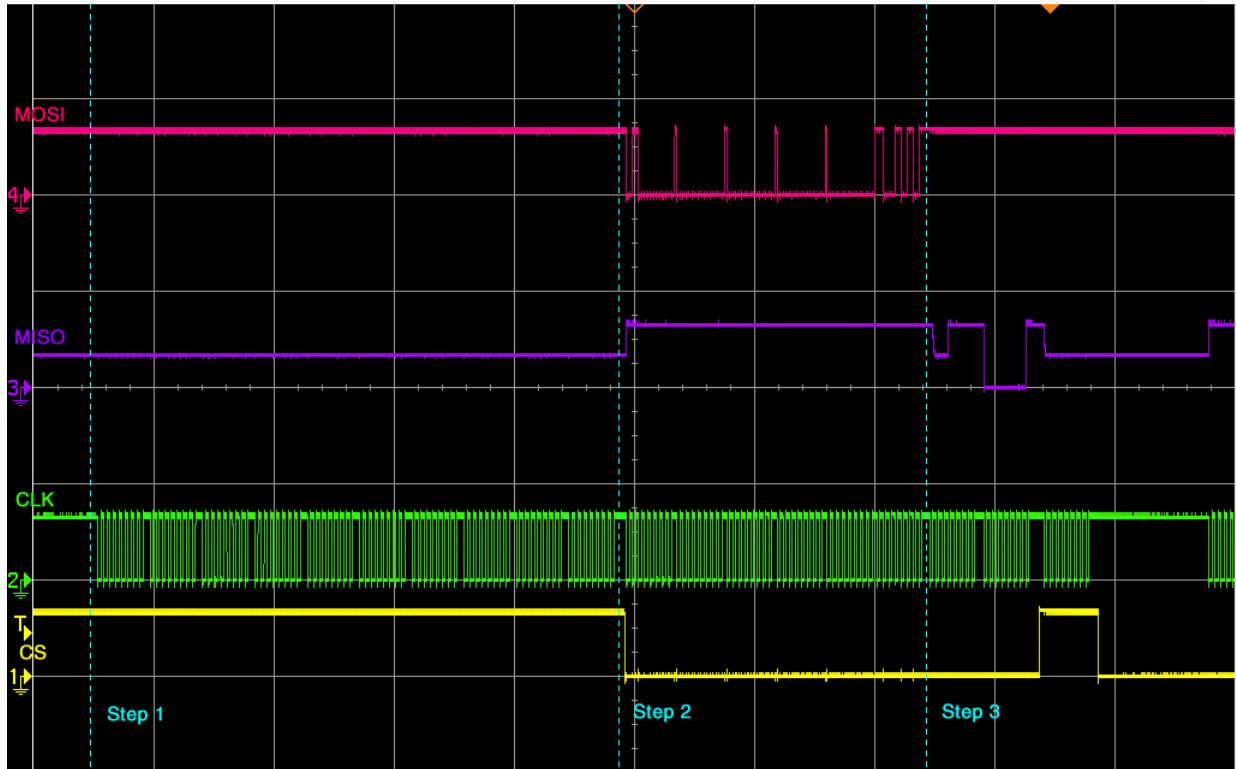

Card initialization

After sending 8 dummy bytes to the card, CS is activated and the `GO_IDLE_STATE` command is sent to the card. The first byte is `0x40` or `b01000000`. You can see (and should verify) that MOSI changes on the falling edge of CLK. The `GO_IDLE_STATE` command is the reset command. It sets the card into idle state regardless of the current card state.

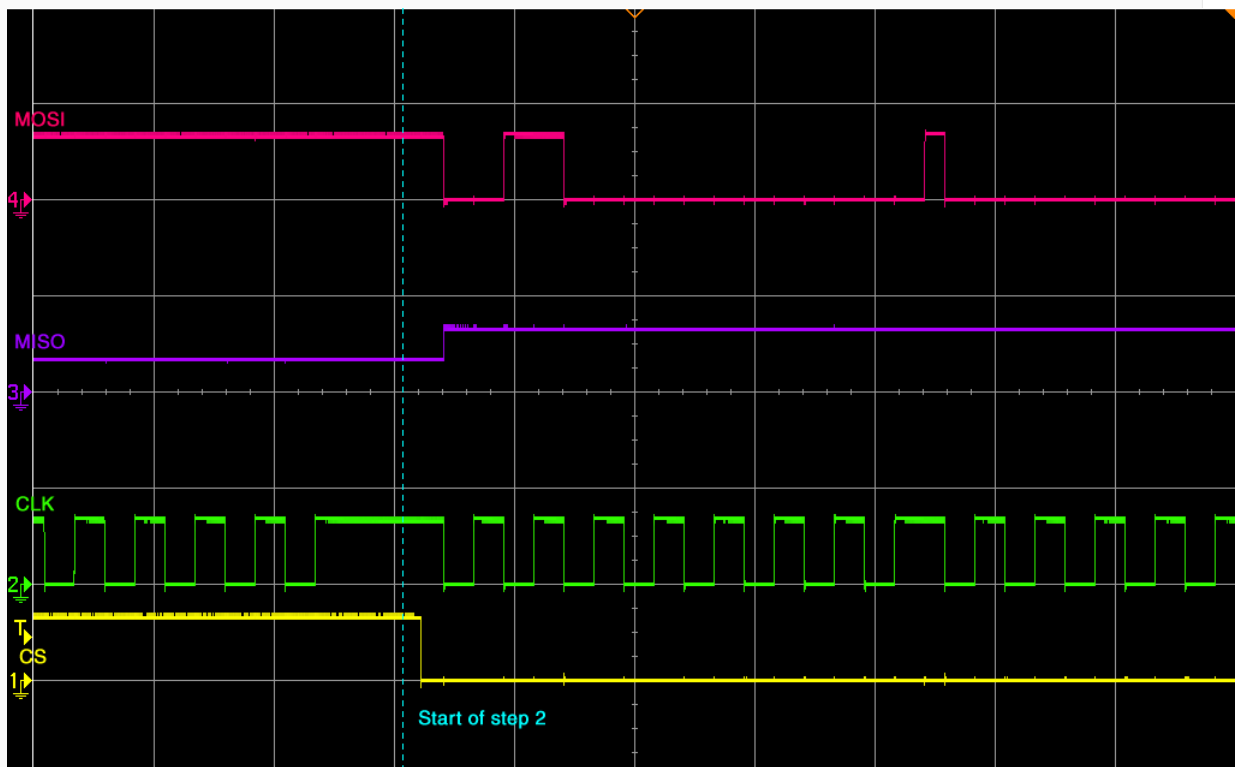

Reset command

The card responds to a command with two bytes. The SD Card Association defines that the first byte of the response should always be ignored. The second byte is the answer from the card. The answer to `GO_IDLE_STATE` command should be `0x01`. This means that the card is in idle state.

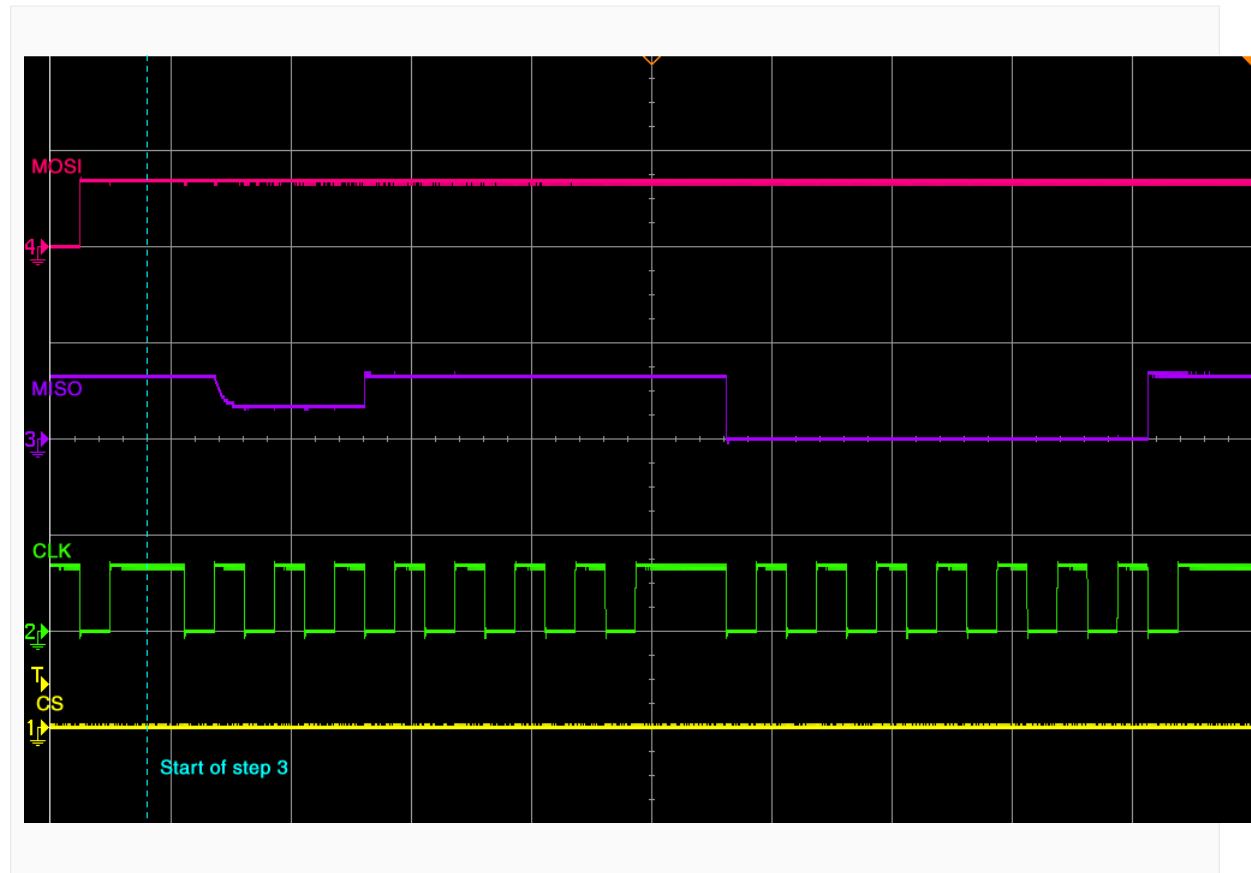

Reset response

If the card does not return `0x01` then check initialization sequence of your hardware. At the end of the command sequence the CS signal has to be deselected that is the signal has to be set to logic high.

6.5.6 Test hardware

The SEGGER SD Card Adapter is an easy to use measurement board that can be used to troubleshoot problems related to interfacing emFile with MMC and SD cards in SPI as well as card mode.

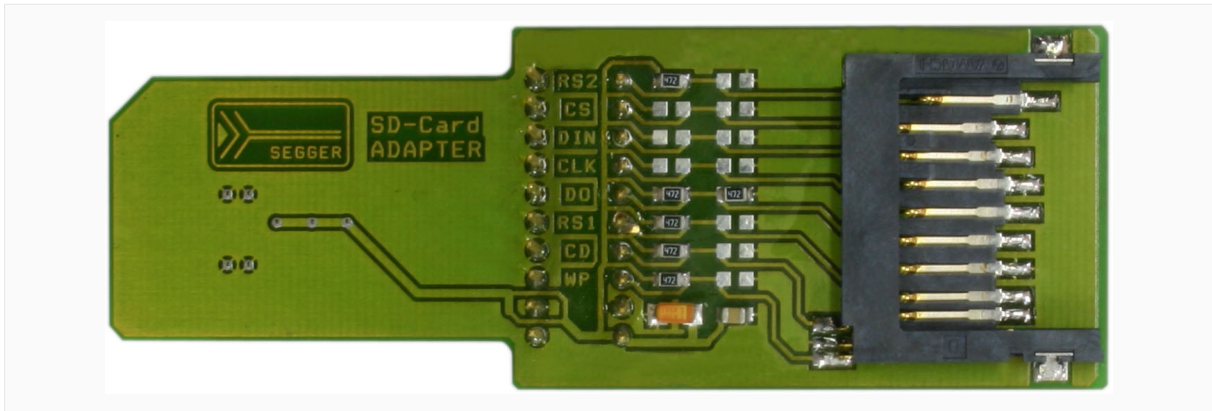

SD card adapter

The adapter board is shaped in the form of an SD card on one side so that it can be directly inserted into any SD card slot. The pads on the same side of the board provide mechanical contact with the signals of SD card slot of the target hardware. The signals are routed on the adapter board to an SD card socket mounted on it where the SD card can be inserted. All the signals are connected to a header where they can be easily captured using an oscilloscope probe. Another header is provided for GND signals.

The picture below shows the schematic of the adapter board.

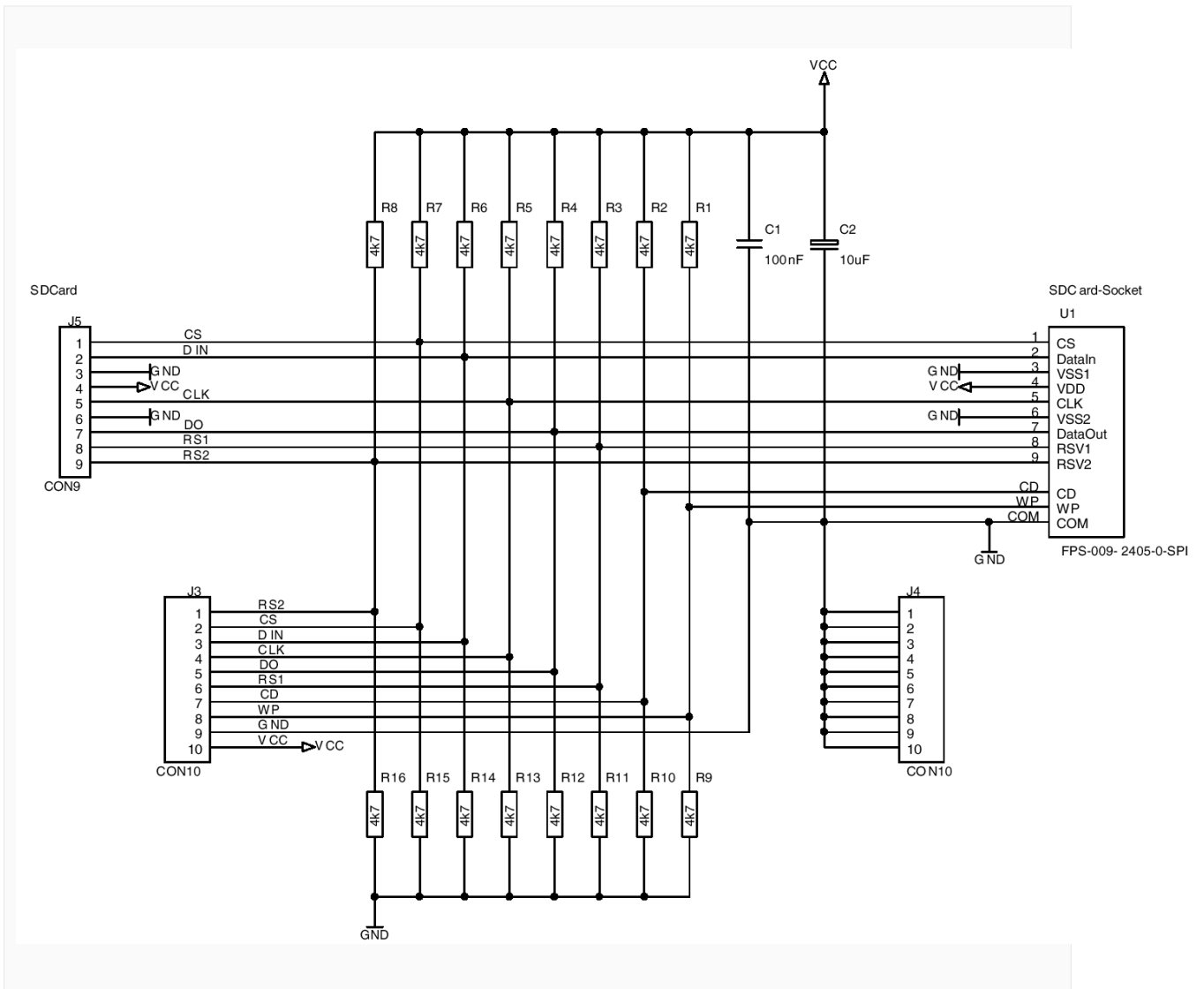

Schematic of SD card adapter

6.6 CompactFlash card and IDE driver

6.6.1 General information

emFile supports the use of CompactFlash (CF) cards and IDE devices as storage device. Both types of storage devices share a common interface and are supported by the CF/IDE driver that is able to operate in different modes specified by this interface. The access to the hardware is realized via a set of I/O routines called CF/IDE hardware layer.

For details on CompactFlash cards check the specification which is available at: <http://www.compactflash.org/>

Information about the AT Attachment interface can be found at the Technical Committee T13 that is responsible for the ATA standard: <http://www.t13.org/>

6.6.1.1 Fail-safe operation

The data will be preserved in case of an unexpected reset but a power failure can be critical. If the card does not have sufficient time to complete a write operation, data may be lost. As a countermeasure the hardware has to make sure that the power supply to the device drops slowly.

6.6.1.2 Wear-leveling

CF cards and IDE devices have an internal controller, that is responsible for performing the wear-leveling. Therefore, the CF/IDE driver does not need to handle wear-leveling.

6.6.1.3 Supported hardware

The CF/IDE driver can be used to access most ATA HD drives and CF cards using the True IDE or Memory card mode.

6.6.1.3.1 Pin description - True IDE mode

The following table describes the signals used in True IDE mode.

Signal name	Dir	Pin	Description
A2-A0	I	18, 19, 20	Only A[2:0] are used to select one of eight registers in the Task File, the remaining address lines should be grounded by the host.
PDIAG	I/O	46	This input / output is the Pass Diagnostic signal in the Master / Slave handshake protocol.
DASP	I/O	45	This input/output is the Disk Active/Slave Present signal in the Master/Slave handshake protocol.
CD1, CD2	O	26, 25	These Card Detect pins are connected to ground on the CompactFlash Storage Card or CF+ Card. They are used by the host to determine that the CompactFlash Storage Card or CF+ Card is fully inserted into its socket.
CS0, CS1	I	7, 32	CS0 is the chip select for the task file registers while CS1 is used to select the Alternate Status Register and the Device Control Register.
CSEL	I	39	This internally pulled up signal is used to configure this device as a Master or a Slave when configured in True IDE Mode. When this pin is grounded, the device is configured as a Master. When the pin is open, the device is configured as a Slave.
D15 - D00	I/O	27 - 31	All Task File operations occur in byte mode on the low order bus D00-D07 while all data transfers are 16 bit using D00-D15.

Signal name	Dir	Pin	Description
		47 - 49 2 - 6 21 - 23	
GND	--	1, 5	Ground.
IORD	I	34	This is an I/O Read strobe generated by the host. This signal gates I/O data onto the bus from the CompactFlash Storage Card or CF+ Card when the card is configured to use the I/O interface.
IOWR	I	35	I/O Write strobe pulse is used to clock I/O data on the Card Data bus into the CompactFlash Storage Card or CF+ Card controller registers when the CompactFlash Storage Card or CF+ Card is configured to use the I/O interface. The clocking will occur on negative to positive edge of the signal (trailing edge).
OE (ATA SEL)	I	9	To enable True IDE Mode this input should be grounded by the host.
INTRQ	O	37	Signal is the active high interrupt request to the host.
REG	I	44	This input signal is not used and should be connected to VCC by the host.
RESET	I	41	This input pin is the active low hardware reset from the host.
VCC	--	13, 38	+5V, +3.3V power.
VS1, VS2	O	33, 4	Voltage Sense Signals. -VS1 is grounded so that the CompactFlash Storage Card or CF+ Card CIS can be read at 3.3 volts and -VS2 is reserved by PCMCIA for a secondary voltage.
IORDY	O	42	This output signal may be used as IORDY
WE	I	36	This input signal is not used and should be connected to VCC by the host.
IOIS16	O	24	This output signal is asserted low when the device is expecting a word data transfer cycle.

6.6.1.3.2 Pin description - Memory card mode

The following table describes the signals used in Memory card mode.

Signal name	Dir	Pin	Description
A10 - A0	I	8, 10, 11, 12, 14, 15, 16, 17, 18, 19, 20	These address lines along with the -REG signal are used to select the following: the I/O port address registers within the CompactFlash Storage Card or CF+ Card, the memory mapped port address registers within the CompactFlash Storage Card or CF+ Card, a byte in the card's information structure and its configuration control and status registers.
BVD1	I/ O	46	This signal is asserted high, as BVD1 is not supported.
BVD2	I/ O	45	This signal is asserted high, as BVD2 is not supported.
CD1, CD2	O	26, 25	These Card Detect pins are connected to ground on the CompactFlash Storage Card or CF+ Card. They are used by the host to determine that the CompactFlash Storage Card or CF+ Card is fully inserted into its socket.

Signal name	Dir	Pin	Description
CE1, CE2	I	7, 32	These input signals are used both to select the card and to indicate to the card whether a byte or a word operation is being performed. -CE2 always accesses the odd byte of the word. We recommend connecting these pins together.
CSEL	I	39	This signal is not used for this mode, but should be grounded by the host.
D15 - D00	I/ O	27 - 31 47 - 49 2 - 6 21 - 23	These lines carry the Data, Commands and Status information between the host and the controller. D00 is the LSB of the Even Byte of the Word. D08 is the LSB of the Odd Byte of the Word.
GND	--	1, 5	Ground.
INPACK	O	43	This signal is not used in this mode.
IORD	I	34	This signal is not used in this mode.
IOWR	I	35	This signal is not used in this mode.
OE (ATA SEL)	I	9	This is an Output Enable strobe generated by the host interface. It is used to read data from the CompactFlash Storage Card or CF+ Card in Memory Mode and to read the CIS and configuration registers.
READY	O	37	In Memory Mode, this signal is set high when the CompactFlash Storage Card or CF+ Card is ready to accept a new data transfer operation and is held low when the card is busy. At power up and at Reset, the READY signal is held low (busy) until the CompactFlash Storage Card or CF+ Card has completed its power up or reset function. No access of any type should be made to the CompactFlash Storage Card or CF+ Card during this time. Note, however, that when a card is powered up and used with +RESET continuously disconnected or asserted, the reset function of this pin is disabled and consequently the continuous assertion of +RESET will not cause the READY signal to remain continuously in the busy state.
REG	I	44	This signal is used during Memory Cycles to distinguish between Common Memory and Register (Attribute) Memory accesses. High for Common Memory, Low for Attribute Memory. To use it with emFile, this signal should be high.
RESET	I	41	When the pin is high, this signal Resets the CompactFlash Storage Card or CF+ Card. The CompactFlash Storage Card or CF+ Card is reset only at power up if this pin is left high or open from power up.
VCC	--	13, 38	+5 V, +3.3 V power.
VS1, VS2	O	33, 4	Voltage Sense Signals. -VS1 is grounded so that the CompactFlash Storage Card or CF+ Card CIS can be read at 3.3 volts and -VS2 is reserved by PCMCIA for a secondary voltage.
WAIT	O	42	The -WAIT signal is driven low by the CompactFlash Storage Card or CF+ Card to signal the host to delay completion of a memory or I/O cycle that is in progress.
WE	I	36	This is a signal driven by the host and used for strobing memory write data to the registers of the CompactFlash Storage Card or CF+ Card when the card is configured in the memory interface mode.

Signal name	Dir	Pin	Description
WP	O	24	The CompactFlash Storage Card or CF+ Card does not have a write protect switch. This signal is held low after the completion of the reset initialization sequence.

6.6.1.4 Theory of operation

6.6.1.4.1 CompactFlash card

A CF card is a mechanically small, removable mass storage device. It contains a single chip controller and one or more flash memory modules in a matchbox-sized package with a 50-pin connector consisting of two rows of 25 female contacts each on 50 mil (1.27 mm) centers. The controller interfaces with a host system allowing data to be written to and read from the flash memory modules.

There are two different Compact Flash Types, namely CF Type I and CF Type II. The only difference between CF Type I and CF Type II cards is the card thickness. CF Type I is 3.3 mm thick and CF Type II cards are 5mm thick. A CF Type I card will operate in a CF Type I or CF Type II slot. A CF Type II card will only fit in a CF Type II slot. The electrical interfaces are identical. CompactFlash is available in both CF Type I and CF Type II cards, though predominantly in CF Type I cards. The Microdrive is a CF Type II card. Most CF I/O cards are CF Type I, but there are some CF Type II I/O cards.

CF cards are designed with flash technology, a nonvolatile storage solution that does not require a battery to retain data indefinitely. The CF card specification version 2.0 supports data rates up to 16MB/sec and capacities up to 137GB. CF cards consume only five percent of the power required by small disk drives.

CompactFlash cards support both 3.3V and 5V operation and can be interchanged between 3.3V and 5V systems. This means that any CF card can operate at either voltage. Other small form factor flash cards may be available to operate at 3.3V or 5V, but any single card can operate at only one of the voltages. CF+ data storage cards are also available using magnetic disk (IBM Microdrive).

CF cards can operate in three modes:

- Memory card mode
- I/O Card mode
- True IDE mode

Currently, only the True IDE and Memory card mode are supported by the CD/IDE driver.

6.6.1.5 IDE (ATA) Drives

Just like Compact Flash cards, ATA drives have a built-in controller to drive and control the mechanical hardware. There are two types of connecting ATA drives. 5.25 and 3.5 inch drives are using a 40 pin male interface to connect to an IDE controller. 2.5 and 1.8 inch drives, mostly used in Notebooks and embedded systems, have a 50 pin male interface.

IDE ATA drives can operate in three different modes:

- PIO (Programmed I/O)
- Multiword DMA
- Ultra DMA

Currently, the CF/IDE driver supports only PIO mode via True IDE.

6.6.1.6 Configuring the driver

This section describes how to configure the file system to make use of the CF/IDE driver.

6.6.1.7 Runtime configuration

The driver must be added to the file system by calling `FS_AddDevice()` with the driver identifier set to the address of `FS_IDE_Driver` structure. This function call together with

other function calls that configure the driver operation have to be added to `FS_X_AddDe-`
`vices()` as demonstrated in the following example.

```
#include "FS.h"
#include "FS_IDE_HW_TrueIDE_Template.h"

#define ALLOC_SIZE 0x800 // Size defined in bytes

static U32 _aMemBlock[ALLOC_SIZE / 4]; // Memory pool used for
// semi-dynamic allocation.

/*****
 *
 *      FS_X_AddDevices
 *
 *  Function description
 *  This function is called by the FS during FS_Init().
 */
void FS_X_AddDevices(void) {
    //
    // Give the file system memory to work with.
    //
    FS_AssignMemory(&_aMemBlock[0], sizeof(_aMemBlock));
    //
    // Add and configure the CF/IDE driver in master mode.
    //
    FS_AddDevice(&FS_IDE_Driver);
    FS_IDE_Configure(0, 0);
    FS_IDE_SetHWType(0, &FS_IDE_HW_TrueIDE_Template);
}
```

The API functions listed in the next table can be used by the application to configure the behavior of the CF/IDE driver. The application can call them only at the file system initialization in `FS_X_AddDevices()`.

Function	Description
<code>FS_IDE_Configure()</code>	Configures a driver instance.
<code>FS_IDE_SetHWType()</code>	Configures the hardware access routines.

6.6.1.7.1 FS_IDE_Configure()

Description

Configures a driver instance.

Prototype

```
void FS_IDE_Configure(U8 Unit,
                    U8 IsSlave);
```

Parameters

Parameter	Description
Unit	Driver index (0-based)
IsSlave	Working mode. <ul style="list-style-type: none"> • 1 Slave mode. • 0 Master mode.

Additional information

This function is optional. The application has to call this function only when the device does not use the default IDE master/slave configuration. By default, all even-numbered units (0, 2, 4...) work in master mode, while all odd-numbered units work in slave mode.

FS_IDE_Configure function has to be called from FS_X_AddDevices() and it can be called before or after adding the device driver to the file system.

Example

The following example demonstrates how to configure two different CF cards or IDE devices:

```
#include "FS.h"
#include "FS_IDE_HW_TrueIDE_Template.h"

#define ALLOC_SIZE 0x800 // Size defined in bytes

static U32 _aMemBlock[ALLOC_SIZE / 4]; // Memory pool used for
// semi-dynamic allocation.

/*****
 *
 * FS_X_AddDevices
 *
 * Function description
 * This function is called by the FS during FS_Init().
 */
void FS_X_AddDevices(void) {
    FS_AssignMemory(&_aMemBlock[0], sizeof(_aMemBlock));
    //
    // Add and configure the first driver.
    // The device works as master on the IDE bus. Volume name: "ide:0:"
    //
    FS_AddDevice(&FS_IDE_Driver);
    FS_IDE_Configure(0, 0);
    FS_IDE_SetHWType(0, &FS_IDE_HW_TrueIDE_Template);
    //
    // Add and configure the second driver.
    // The device works also as master on the IDE bus. Volume name: "ide:1:"
    //
    FS_AddDevice(&FS_IDE_Driver);
    FS_IDE_Configure(1, 0);
    FS_IDE_SetHWType(1, &FS_IDE_HW_TrueIDE_Template);
}
```

6.6.1.7.2 FS_IDE_SetHWType()

Description

Configures the hardware access routines.

Prototype

```
void FS_IDE_SetHWType(      U8          Unit,
                          const FS_IDE_HW_TYPE * pHWType);
```

Parameters

Parameter	Description
Unit	Driver index (0-based)
pHWType	in Hardware access routines (hardware layer).

Additional information

This function is mandatory. The `FS_IDE_HW_Default` hardware layer is provided to help the porting to the new hardware layer API. This hardware layer contains pointers to the public functions used by the device driver to access the hardware in the version 3.x of emFile. Configure `FS_IDE_HW_Default` as hardware layer if you do not want to port your existing hardware layer to the new hardware layer API.

Example

For an example usage refer to `FS_IDE_Configure()`.

6.6.2 CF/IDE hardware layer

The CF/IDE hardware layer provides the functions to access the target hardware (IDE controller, GPIO, etc.). They have to be implemented by the user since they are hardware dependent. emFile comes with template hardware layers and some sample implementations for popular evaluation boards. These files can be found in the `Sample/FS/Driver/IDE` folder of the emFile shipment. The functions are organized in a function table which is a structure of type `FS_IDE_HW_TYPE`.

6.6.2.1 Hardware layer API - FS_IDE_HW_TYPE

This hardware layer supports all CF cards and IDE devices. The following sections describe the functions of this hardware layer in detail.

6.6.2.1.1 FS_IDE_HW_TYPE

Description

Hardware layer API

Type definition

```
typedef struct {
    FS_IDE_HW_TYPE_RESET      * pfReset;
    FS_IDE_HW_TYPE_IS_PRESENT * pfIsPresent;
    FS_IDE_HW_TYPE_DELAY_400NS * pfDelay400ns;
    FS_IDE_HW_TYPE_READ_REG    * pfReadReg;
    FS_IDE_HW_TYPE_WRITE_REG   * pfWriteReg;
    FS_IDE_HW_TYPE_READ_DATA   * pfReadData;
    FS_IDE_HW_TYPE_WRITE_DATA  * pfWriteData;
} FS_IDE_HW_TYPE;
```

Structure members

Member	Description
pfReset	Resets the bus interface.
pfIsPresent	Checks if the device is connected.
pfDelay400ns	Blocks the execution for 400ns.
pfReadReg	Reads the value of a register.
pfWriteReg	Writes the value of a register.
pfReadData	Transfers data from device to MCU.
pfWriteData	Transfers data from MCU do device.

6.6.2.1.2 FS_IDE_HW_TYPE_RESET

Description

Resets the bus interface.

Type definition

```
typedef void FS_IDE_HW_TYPE_RESET(U8 Unit);
```

Parameters

Parameter	Description
<code>Unit</code>	Index of the hardware layer instance (0-based)

Additional information

This function is a member of the CF/IDE hardware layer. All hardware layers are required to implement this function.

This function is called when the driver detects a new storage device. For ATA HD drives, there is no action required and this function can be left empty.

6.6.2.1.3 FS_IDE_HW_TYPE_IS_PRESENT

Description

Checks presence status of the storage device.

Type definition

```
typedef int FS_IDE_HW_TYPE_IS_PRESENT(U8 Unit);
```

Parameters

Parameter	Description
<code>Unit</code>	Index of the hardware layer instance (0-based)

Return value

≠ 0 Device is present.
= 0 Device is not present.

Additional information

This function is a member of the CF/IDE hardware layer. All hardware layers are required to implement this function.

6.6.2.1.4 FS_IDE_HW_TYPE_DELAY_400NS

Description

Blocks the execution for 400ns.

Type definition

```
typedef void FS_IDE_HW_TYPE_DELAY_400NS(U8 Unit);
```

Parameters

Parameter	Description
<code>Unit</code>	Index of the hardware layer instance (0-based)

Additional information

This function is a member of the CF/IDE hardware layer. All hardware layers are required to implement this function.

The function is always called when a command is sent or parameters are set in the CF card or IDE device to give the integrated logic time to finish a command. When using slow CF cards or IDE devices with fast processors this function should guarantee that a delay of 400ns is respected. However, this function may be left empty if you fast devices are used (modern CF-Cards and IDE drives are faster than 400ns when executing commands.)

6.6.2.1.5 FS_IDE_HW_TYPE_READ_REG

Description

Reads the value of a register.

Type definition

```
typedef U16 FS_IDE_HW_TYPE_READ_REG(U8      Unit,
                                     unsigned RegOff);
```

Parameters

Parameter	Description
<code>Unit</code>	Index of the hardware layer instance (0-based)
<code>RegOff</code>	Offset of the register that has to be read.

Return value

Value read from the register.

Additional information

This function is a member of the CF/IDE hardware layer. All hardware layers are required to implement this function.

`RegOff` is always a multiple of two value because the IDE driver always reads two 8-bit registers at a time. The value of the register at the offset `RegOff` must be stored in the low-order byte of the return value while the value of the register at `RegOff + 1` in the high-order byte.

Possible values for `RegOff`:

Value	Register name (data high / low)
0x06	Status / not used
0x0C	Dup. Error / not used
0x0E	not used / Alt Status

6.6.2.1.6 FS_IDE_HW_TYPE_WRITE_REG

Description

Writes the value of a register.

Type definition

```
typedef void FS_IDE_HW_TYPE_WRITE_REG(U8      Unit,
                                       unsigned RegOff,
                                       U16      Data);
```

Parameters

Parameter	Description
Unit	Index of the hardware layer instance (0-based)
RegOff	Offset of the register that has to be written.
Data	Value to be written to the specified register.

Additional information

This function is a member of the CF/IDE hardware layer. All hardware layers are required to implement this function.

[RegOff](#) is always a multiple of two value because the IDE driver always writes two 8-bit registers at a time. The value of the register at the offset [RegOff](#) is stored in the low-order byte of [Data](#) while the value of the register at the offset [RegOff](#) + 1 in the high-order byte of [Data](#).

Possible values for [RegOff](#):

Value	Register name (data high / low)
0x02	Sector No. / Sector Count
0x04	Cylinder High / Cylinder Low
0x06	Command / Select Card and Head
0x0C	Dup. Features / not used
0x0E	not used / Device Ctl

6.6.2.1.7 FS_IDE_HW_TYPE_READ_DATA

Description

Transfers data from device to MCU.

Type definition

```
typedef void FS_IDE_HW_TYPE_READ_DATA(U8      Unit,
                                       U8      * pData,
                                       unsigned NumBytes);
```

Parameters

Parameter	Description
<code>Unit</code>	Index of the hardware layer instance (0-based)
<code>pData</code>	<code>out</code> Data transferred from device.
<code>NumBytes</code>	Number of bytes to be transferred.

Additional information

This function is a member of the CF/IDE hardware layer. All hardware layers are required to implement this function.

`pData` is always 16-bit aligned in order to enable the reading of two bytes at a time. For the same reason, `NumBytes` is always a multiple of two value.

6.6.2.1.8 FS_IDE_HW_TYPE_WRITE_DATA

Description

Transfers data from MCU do device.

Type definition

```
typedef void FS_IDE_HW_TYPE_WRITE_DATA(      U8      Unit,
                                             const U8      * pData,
                                             unsigned NumBytes);
```

Parameters

Parameter	Description
<code>Unit</code>	Index of the hardware layer instance (0-based)
<code>pData</code>	in Data to be transferred to device.
<code>NumBytes</code>	Number of bytes to be transferred.

Additional information

This function is a member of the CF/IDE hardware layer. All hardware layers are required to implement this function.

`pData` is always 16-bit aligned in order to enable the writing of two bytes at a time. For the same reason, `NumBytes` is always a multiple of two value.

6.6.3 Performance and resource usage

6.6.3.1 ROM usage

The ROM usage depends on the compiler options, the compiler version, and the used CPU. The memory requirements of the IDE/CF driver were measured as described in the section *Test procedure* on page 1283.

Usage: 1.6 Kbytes

6.6.3.2 Static RAM usage

Static RAM usage is the amount of RAM required by the driver for variables inside the driver. The number of bytes can be seen in a compiler list file.

Usage: 24 bytes

6.6.3.2.1 Dynamic RAM usage

Dynamic RAM usage is the amount of RAM allocated by the driver at runtime. The amount of RAM required depends on the runtime configuration.

Usage: 18 bytes

6.6.3.3 Performance

These performance measurements are in no way complete, but they give an approximation of the length of time required for common operations on various targets. The tests were performed as described in the section *Performance* on page 1289. All values are given in Mbytes/sec.

CPU type	Storage device	Write speed	Read speed
LogicPD H79520 (51 MHz)	IDE memory-mapped	1.4	1.7
Cogent EP7312 (74 MHz)	CompacFlash card, True IDE mode	1.9	2.5
Cogent EP7312 (74 MHz)	HDD, True IDE mode	1.7	2.4

6.7 Windows Drive driver

This driver can be used to access the data stored on any drive of a Windows operating system via the emFile API functions. Typical usage includes testing and evaluation emFile before deployment on a target hardware. The Windows Drive driver is also able to use a regular file stored on the file system of the Windows PC as storage.

6.7.1 Supported hardware

The Windows Drive driver is compatible with any Windows operating system version newer as Windows 98. Older Windows version not supported, because they do not provide access to a Windows drive via the API functions. Windows drives formatted as NTFS are not supported.

6.7.2 Theory of operation

The driver works by reading and writing entire logical sectors. The size of a logical sector can be specified at compile time via `FS_WINDRIVE_SECTOR_SIZE` or at runtime via `FS_WINDRIVE_SetGeometry()`. The size of the logical sector has to match the size of the logical sector used by the Windows drive. Any logical sector size can be used if the Windows Drive driver is configured to use a regular file as storage. On some Windows systems, administrator privileges are required to access a Windows drive. The Windows Drive driver reports an error if the user does not have the required privileges.

Note

Do not use this driver on partitions containing important data. Windows Drive driver is primarily meant to be used for evaluation purposes. Problems may occur if the program using emFile is debugged or terminated unexpectedly using the Windows Task Manager.

6.7.3 Fail-safe operation

The driver is not designed to be used on a target hardware therefore the fail-safe operation is not relevant. However, the fail-safe operation is generally guaranteed because it is handled by the underlying operating system and hardware.

6.7.4 Wear-leveling

The driver does not perform any wear leveling. The wear leveling is handled by the storage device.

6.7.5 Configuring the Windows Drive driver

6.7.5.1 Compile time configuration

The configuration at compile time is realized via preprocessor defines that have to be added to the `FS_Conf.h` file which is the main configuration file of emFile. For detailed information about the configuration of emFile and of the configuration define types, refer to *Configuration of emFile* on page 1218

The Windows Drive driver does not require any hardware access functions.

The following table lists the configuration defines supported by the Windows Drive driver.

Type	Define	Default value	Description
N	<code>FS_WINDRIVE_SECTOR_SIZE</code>	512	Default size of a logical sector in bytes.

Type	Define	Default value	Description
N	FS_WINDRIVE_NUM_UNITS	4	Maximum number of driver instances.

6.7.5.1.1 FS_WINDRIVE_SECTOR_SIZE

This define specifies the default size of the logical sector when the driver is configured to use a regular file as storage. This value can be modified at runtime via `FS_WINDRIVE_SetGeometry()`

6.7.5.1.2 FS_WINDRIVE_NUM_UNITS

This define specifies the maximum number of driver instances that can be created by the application. The memory for each driver instance is allocated dynamically from the memory pool assigned to file system.

6.7.5.2 Runtime configuration

The driver can be added to the file system by calling `FS_AddDevice()` with the driver label `FS_WINDRIVE_Driver`. This function call together with other function calls that configure the driver operation has to be added to `FS_X_AddDevices()` as demonstrated in the following example.

Example

```
#include "FS.h"

#define FS_ALLOC_SIZE      0x1000          // Memory pool for the file system in bytes

static U32 _aMemBlock[FS_ALLOC_SIZE / 4]; // Memory pool used for semi-dynamic allocation.

void FS_X_AddDevices(void) {
    FS_AssignMemory(&_aMemBlock[0], sizeof(_aMemBlock));
#ifdef _WIN32
    //
    // Add and configure the driver to access the Windows drive with the letter 'E'.
    //
    FS_AddDevice(&FS_WINDRIVE_Driver);
    FS_WINDRIVE_Configure(0, "\\\\.\\E:");
#endif // _WIN32
#ifdef FS_SUPPORT_FILE_BUFFER
    //
    // Enable the file buffer to increase the performance
    // when reading and writing a small number of bytes.
    //
    FS_ConfigFileBufferDefault(512, FS_FILE_BUFFER_WRITE);
#endif // FS_SUPPORT_FILE_BUFFER
}
```

The API functions listed in the next table can be used by the application to configure the behavior of the Windows Drive driver. The application can call them only at the file system initialization in `FS_X_AddDevices()`.

Function	Description
<code>FS_WINDRIVE_Configure()</code>	Configures a driver instance.
<code>FS_WINDRIVE_ConfigureEx()</code>	Configures a driver instance.
<code>FS_WINDRIVE_SetGeometry()</code>	Configures the storage capacity of an image file.

6.7.5.2.1 FS_WINDRIVE_Configure()

Description

Configures a driver instance.

Prototype

```
void FS_WINDRIVE_Configure(      U8      Unit,
                               const char * sName);
```

Parameters

Parameter	Description
<code>Unit</code>	Index of the instance to configure (0-based)
<code>sName</code>	in Name of the Windows drive or of the image file to be used as storage. Can be <code>NULL</code> .

Additional information

Either `FS_WINDRIVE_Configure()` or `FS_WINDRIVE_ConfigureEx()` has to be called once for each instance of the WINDRIVE driver. `sName` is a 0-terminated wide char string that stores the path to the Windows drive or to the image file to be used as storage.

If `sName` is set to `NULL` the driver shows a dialog box that allows the user to select a specific drive from a list of available Windows drives. If `sName` is a path to a regular file that file has to exist before `FS_WINDRIVE_ConfigureEx()` is called. Selecting a Windows drive as storage requires administrator privileges. The file system reports an error to the application if this is not the case and the application will not be able to access the to use the Windows drive as storage.

The size of the logical sector used by the WinDrive driver can be configured at compile time via `FS_WINDRIVE_SECTOR_SIZE` or at runtime via `FS_WINDRIVE_SetGeometry()`.

Example

Refer to *Runtime configuration* on page 395 for a sample usage.

6.7.5.2.2 FS_WINDRIVE_ConfigureEx()

Description

Configures a driver instance.

Prototype

```
void FS_WINDRIVE_ConfigureEx(U8      Unit,
                             LPCWSTR sName);
```

Parameters

Parameter	Description
Unit	Index of the instance to configure (0-based)
sName	in Name of the Windows drive or of the image file to be used as storage. Can be NULL.

Additional information

This function performs the same operation as `FS_WINDRIVE_Configure()` with the difference that `sName` is a pointer to a 0-terminated string containing wide characters. `FS_WINDRIVE_ConfigureEx()` has to be used when the path to the Windows drive or image file can contain non-ASCII characters.

`sName` has to point to 0-terminated string containing wide characters. A string literal can be declared in C by prefixing it with the 'L' character. For example the path to the drive with the letter 'E' can be specified as `L"\\\\.\\E:"`

If `sName` is set to `NULL` the driver shows a dialog box that allows the user to select a specific drive from a list a list of available Windows drives. If `sName` is a path to a regular file that file has to exist before `FS_WINDRIVE_ConfigureEx()` is called. Selecting a Windows drive as storage requires administrator privileges. The file system reports an error to the application if this is not the case and the application will not be able to access the to use the Windows drive as storage.

The size of the logical sector used by the WINDRIVE driver can be configured at compile time via `FS_WINDRIVE_SECTOR_SIZE` or at runtime via `FS_WINDRIVE_SetGeometry()`.

Example

```
#include "FS.h"

#define FS_ALLOC_SIZE      0x1000          // Memory pool for the file system in bytes

static U32 _aMemBlock[FS_ALLOC_SIZE / 4]; // Memory pool used for semi-dynamic allocation.

void FS_X_AddDevices(void) {
    FS_AssignMemory(&_aMemBlock[0], sizeof(_aMemBlock));
#ifdef _WIN32
    //
    // Add and configure the driver to access the Windows drive with
    // the letter 'E' assigned to it.
    //
    FS_AddDevice(&FS_WINDRIVE_Driver);
    FS_WINDRIVE_ConfigureEx(0, L"\\\\.\\E:");
#endif // _WIN32
#ifdef FS_SUPPORT_FILE_BUFFER
    //
    // Enable the file buffer to increase the performance when reading/writing a small number of bytes.
    //
    FS_ConfigFileBufferDefault(512, FS_FILE_BUFFER_WRITE);
#endif // FS_SUPPORT_FILE_BUFFER
}
```

6.7.5.2.3 FS_WINDRIVE_SetGeometry()

Description

Configures the storage capacity of an image file.

Prototype

```
int FS_WINDRIVE_SetGeometry(U8 Unit,
                           U32 BytesPerSector,
                           U32 NumSectors);
```

Parameters

Parameter	Description
Unit	Index of the instance to configure (0-based)
BytesPerSector	Number of bytes in a logical sector. Has to be a power of 2 value.
NumSectors	Number of logical sectors that can be stored to the image file.

Return value

= 0 OK, parameters set.
 ≠ 0 Error code indicating the failure reason.

Additional information

This function is optional. When not called the driver uses the sector size configured via `FS_WINDRIVE_SECTOR_SIZE`. The number of sectors is calculated by dividing the size of the image file to `FS_WINDRIVE_SECTOR_SIZE`. This implies that by default the driver fails to initialize if the image file is missing.

Calling `FS_WINDRIVE_SetGeometry()` changes the behavior of the driver during initialization in that the driver will try to create the image file if missing. In addition, if an image file is present the driver checks verifies if the size of the image file matches the size configured via `FS_WINDRIVE_SetGeometry()` and if not it recreates the image file.

The size of the image file in bytes is `NumSectors * BytesPerSector`. Image files larger than or equal to 4 Gbytes are not supported.

Example

```
#include "FS.h"

#define FS_ALLOC_SIZE      0x1000          // Memory pool for the file system in bytes
#define BYTES_PER_SECTOR  512             // Logical sector size in bytes
#define NUM_SECTORS       1024           // Number of logical sectors

static U32 _aMemBlock[FS_ALLOC_SIZE / 4]; // Memory pool used for semi-dynamic allocation.

void FS_X_AddDevices(void) {
    FS_AssignMemory(&_aMemBlock[0], sizeof(_aMemBlock));
#ifdef _WIN32
    //
    // Add and configure the driver to use a regular file as storage.
    //
    FS_AddDevice(&FS_WINDRIVE_Driver);
    FS_WINDRIVE_Configure(0, "C:\\Temp\\WinDrive.bin");
    FS_WINDRIVE_SetGeometry(0, BYTES_PER_SECTOR, NUM_SECTORS);
#endif // _WIN32
#ifdef FS_SUPPORT_FILE_BUFFER
    //
    // Enable the file buffer to increase the performance when reading/writing a small number of bytes.
    //
    FS_ConfigFileBufferDefault(512, FS_FILE_BUFFER_WRITE);
#endif // FS_SUPPORT_FILE_BUFFER
```

```
}
```

6.8 File Disk driver

This driver uses as storage a regular file located on the host file system. Typical usage includes testing and evaluation emFile before deployment on a target hardware.

6.8.1 Supported hardware

The File Disk driver is compatible with any Windows or Linux operating system.

6.8.2 Theory of operation

The driver works by reading and writing entire logical sectors. The size of a logical sector as well as the number of logical sectors can be specified at runtime time via `FS_FILEDISK_Configure()`. Any logical sector size is supported.

The file used as storage is automatically created if it does not exist. If the file already exists then the size of the file is truncated to the size configured via `FS_FILEDISK_Configure()`.

6.8.3 Fail-safe operation

The File Disk driver is not designed to be used on a target hardware therefore the fail-safe operation is not relevant. However, the fail-safe operation is generally guaranteed because it is handled by the underlying operating system and hardware.

6.8.4 Wear-leveling

The File Disk driver does not perform any wear leveling. The wear leveling is handled by the underlying operating system and hardware.

6.8.5 Configuring the File Disk driver

6.8.5.1 Compile time configuration

The configuration at compile time is done via preprocessor defines that have to be added to the `FS_Conf.h` file the is the main configuration file of emFile. For detailed information about the configuration of emFile and of the configuration define types, refer to *Configuration of emFile* on page 1218

The File Disk driver does not require any hardware access functions.

The following table lists the configuration defines supported by the File Disk driver.

Type	Define	Default value	Description
N	<code>FS_FILEDISK_NUM_UNITS</code>	1	Maximum number of driver instances.
B	<code>FS_FILEDISK_SUPPORT_TRIM</code>	0	Enables or disables the support for marking logical sectors are not being in use.

6.8.5.1.1 FS_FILEDISK_NUM_UNITS

This define specifies the maximum number of driver instances that can be created by the application. The memory for each driver instance is allocated dynamically from the memory pool assigned to file system.

6.8.5.1.2 FS_FILEDISK_SUPPORT_TRIM

`FS_FILEDISK_SUPPORT_TRIM` can be used to enable or disable the handling of file system operations that inform the File Disk driver about logical sectors that are no longer in use. This functionality is optional and not required for the correct operation of the File Disk driver. The *Storage Image Creator* utility uses this functionality for implementation of the

exportimage command. The information about the usage of the logical sectors is stored to a separate status file located in the same directory as the data file used for the storage of the file system data. The name of the status file is created by appending the ".sta" file extension to the name of the data file.

6.8.5.2 Runtime configuration

The driver can be added to the file system by calling `FS_AddDevice()` with the driver label `FS_FILEDISK_Driver`. This function call together with other function calls that configure the driver operation has to be added to `FS_X_AddDevices()` as demonstrated in the following example.

Example

```
#include "FS.h"

#define FS_ALLOC_SIZE      0x1000          // Memory pool for the file system in bytes.

static U32 _aMemBlock[FS_ALLOC_SIZE / 4]; // Memory pool used for semi-dynamic allocation.

void FS_X_AddDevices(void) {
    FS_AssignMemory(&_aMemBlock[0], sizeof(_aMemBlock));
#ifdef _WIN32
    //
    // Add and configure the driver to use the "FileDisk.bin" as storage.
    // The total capacity of the storage device is 512 * 1024 = 512 KB
    //
    FS_AddDevice(&FS_FILEDISK_Driver);
    FS_FILEDISK_Configure(0, "FileDisk.bin", 512, 1024);
#endif // _WIN32
#if FS_SUPPORT_FILE_BUFFER
    //
    // Enable the file buffer to increase the performance
    // when reading and writing a small number of bytes.
    //
    FS_ConfigFileBufferDefault(512, FS_FILE_BUFFER_WRITE);
#endif // FS_SUPPORT_FILE_BUFFER
}
```

The API functions listed in the next table can be used by the application to configure the behavior of the File Disk driver. The application can call these functions only at the file system initialization in `FS_X_AddDevices()`.

Function	Description
<code>FS_FILEDISK_Configure()</code>	Configures a driver instance.

6.8.5.2.1 FS_FILEDISK_Configure()

Description

Configures a driver instance.

Prototype

```
int FS_FILEDISK_Configure(    U8          Unit,
                             const char *  sFileName,
                             unsigned     BytesPerSector,
                             U32          NumSectors);
```

Parameters

Parameter	Description
Unit	Index of the instance to configure (0-based)
sFileName	<input type="text"/> Path to the file to be used as storage.
BytesPerSector	Number of bytes in a logical sector.
NumSectors	Number of logical sectors to be used as storage.

Return value

= 0 OK, instance configured successfully.
 ≠ 0 Error code indicating the failure reason.

Additional information

FS_FILEDISK_Configure() has to be called once for each instance of the File Disk driver. The application is allowed to call this function only at file system initialization in FS_X_Ad-dDevices().

sFileName is a 0-terminated character string that stores the path to the file to be used as storage. A copy of this path is stored to the driver instance.

If BytesPerSector is set to 0 then the File Disk driver uses the the maximum logical sector size configured for the file system. By default, the maximum logical sector size is set to 512 bytes. This value can be modified via FS_SetMaxSectorSize().

If the file used as storage does not exist then the file is created when the driver is initialized. The size of the created file is calculated as BytesPerSector * NumSectors. If the file used as storage exists and NumSectors is different than 0 then the size of the file is set to BytesPerSector * NumSectors. If the file used as storage exists and NumSectors is set to 0 then the actual number of sectors is calculated based on the size of the file used as storage.

Example

Refer to *Runtime configuration* on page 395 for a sample usage.

6.8.5.3 Additional driver functions

The functions documented in this section are optional. They can be used to get information about the status of the File Disk driver.

Function	Description
<code>FS_FILEDISK_GetDiskInfo()</code>	Returns information about the storage device.

6.8.5.3.1 FS_FILEDISK_GetDiskInfo()

Description

Returns information about the storage device.

Prototype

```
int FS_FILEDISK_GetDiskInfo(U8 Unit,  
FS_FILEDISK_DISK_INFO * pDiskInfo);
```

Parameters

Parameter	Description
<code>Unit</code>	Index of the instance to configure (0-based)
<code>pDiskInfo</code>	<code>out</code> Storage device information. It cannot be <code>NULL</code> .

Return value

- = 0 OK, information returned successfully.
- ≠ 0 Error code indicating the failure reason.

6.8.5.3.2 FS_FILEDISK_DISK_INFO

Description

Management information maintained by the File Disk driver.

Type definition

```
typedef struct {  
    U64          NumBytes;  
    U16          BytesPerSector;  
    const char * sFileName;  
} FS_FILEDISK_DISK_INFO;
```

Structure members

Member	Description
<code>NumBytes</code>	Capacity of the storage device in bytes.
<code>BytesPerSector</code>	Size of the logical sector used by the driver in bytes.
<code>sFileName</code>	Name of the file that is used as storage.

Chapter 7

Logical drivers

This chapter describes the file system components that provide block processing.

7.1 General information

A logical driver is a file system component that provides block processing of the data exchanged between the Storage layer and the storage device such as partitioning and encryption. It implements the same interface as a device driver but in contrast to a device driver it does not access any storage device. Instead, the requests received from the Storage layer are processed internally and then forwarded to either another logical driver or to a device driver to perform the data access.

The following table lists the available logical drivers.

Driver name	Acronym	Identifier	Volume name
<i>Disk Partition driver</i>	DISKPART	FS_DISKPART_Driver	"diskpart:"
<i>Encryption driver</i>	CRYPT	FS_CRYPT_Driver	"crypt:"
<i>Sector Read-Ahead driver</i>	READAHEAD	FS_READAHEAD_Driver	"rah:"
<i>Sector Size Adapter driver</i>	SECSIZE	FS_SECSIZE_Driver	"secsize:"
<i>Sector Write Buffer driver</i>	WRBUF	FS_WRBUF_Driver	"wrbuf:"
<i>RAID1 driver</i>	RAID1	FS_RAID1_Driver	"raid:"
<i>RAID5 driver</i>	RAID5	FS_RAID5_Driver	"raid:"
<i>Logical Volume driver</i>	LOGVOL	FS_LOGVOL_Driver	"lvol:"

A logical driver has to be added to the file system in the same way as a device driver. To add a logical driver to emFile, `FS_AddDevice()` has to be called with the address of the corresponding driver identifier as parameter. For more information about the usage of the names listed in the "Volume name" column refer to *General information* on page 390

7.2 Disk Partition driver

This logical driver can be used to access storage device partitions as defined by Master Boot Record (MBR) or GUID Partition Table (GPT). Typically, the partitioning information is stored in the first logical sectors of a storage device.

7.2.1 Master Boot Record

A MBR contains information about how the storage device is divided and an optional machine code for bootstrapping PC-compatible computers. This information is always stored on the first logical sector of the storage device. The partitioning information is organized in a table that contains four entries of 16 bytes. Each entry stores the following information about the partition:

Offset (bytes)	Size (byte)	Description
0	1	Partition status: <ul style="list-style-type: none"> • 0x80 - bootable • 0x00 - non-bootable Any other value is invalid.
1	3	First sector in the partition as cylinder/head/sector address.
4	1	Partition type.
5	3	Last sector in the partition as cylinder/head/sector address.
8	4	First sector in the partition as logical block address.
12	4	Number of sectors in the partition.

The driver uses only the information stored in a valid partition table entry. Invalid partition table entries are ignored. The position and the size of the partition are taken from the last two fields in the entry. The cylinder, head and sector information as well as the partition type are also ignored.

A separate volume is assigned to each driver instance. The volumes can be accessed using the following names: "diskpart:0:", "diskpart:1:", "diskpart:2:" and "diskpart:3:".

Note

This logical driver is not required if an application has to access only the first storage device partition, as emFile uses this partition by default.

7.2.2 Configuring the driver

7.2.2.1 Runtime configuration

To add the driver, use `FS_AddDevice()` with the driver identifier set to `FS_DISKPART_Driver`. This function has to be called from within `FS_X_AddDevices()`. Refer to `FS_X_AddDevices()` for more information. The following table lists the API functions that can be called by the application to configure the driver.

Function	Description
<code>FS_DISKPART_Configure()</code>	Configures the parameters of a driver instance.

7.2.2.1.1 FS_DISKPART_Configure()

Description

Configures the parameters of a driver instance.

Prototype

```
void FS_DISKPART_Configure(      U8          Unit,
                               const FS_DEVICE_TYPE * pDeviceType,
                               U8          DeviceUnit,
                               U8          PartIndex);
```

Parameters

Parameter	Description
Unit	Index of the DISKPART instance to configure.
pDeviceType	Type of device driver that is used to access the storage device.
DeviceUnit	Index of the device driver instance that is used to access the storage device (0-based).
PartIndex	Index of the partition in the partition table stored in MBR.

Additional information

This function has to be called once for each instance of the driver. The application can use `FS_DISKPART_Configure()` to set the parameters that allows the driver to access the partition table stored in Master Boot Record (MBR). The size and the position of the partition are read from MBR on the first access to storage device.

Example

This example demonstrates how to configure the file system to access the first two MBR partitions of an SD card.

```
#include "FS.h"

#define ALLOC_SIZE 2048 // Size of emFile memory pool

static U32 _aMemBlock[ALLOC_SIZE / 4];

/*****
 *
 *      FS_X_AddDevices
 *
 *      Function description
 *      This function is called by the FS during FS_Init().
 */
void FS_X_AddDevices(void) {
    U8 DeviceUnit;
    U8 PartIndex;
    U8 Unit;
    FS_AssignMemory(_aMemBlock, sizeof(_aMemBlock));
    //
    // Add SD/MMC card device driver.
    //
    DeviceUnit = 0;
    FS_AddPhysDevice(&FS_MMC_CM_Driver);
    //
    // Configure logical driver to access the first MBR partition.
    // Partition will be mounted as volume "diskpart:0:".
    //
    PartIndex = 0;
    Unit      = 0;
    FS_AddDevice(&FS_DISKPART_Driver);
    FS_DISKPART_Configure(Unit, &FS_MMC_CM_Driver, DeviceUnit, PartIndex);
    //
    // Configure logical driver to access the second MBR partition.
```

```
// Partition will be mounted as volume "diskpart:1:".  
//  
PartIndex = 1;  
Unit      = 1;  
FS_AddDevice(&FS_DISKPART_Driver);  
FS_DISKPART_Configure(Unit, &FS_MMC_CM_Driver, DeviceUnit, PartIndex);  
}
```

7.2.3 Performance and resource usage

7.2.3.1 ROM usage

The ROM usage depends on the compiler options, the compiler version and the used CPU. The memory requirements of the driver presented in the tables below were measured as described in the section *Test procedure* on page 1283.

Usage: 1.5 Kbytes

7.2.3.2 Static RAM usage

Static RAM usage is the amount of RAM required by the driver for variables inside of the driver. The number of bytes can be seen in the compiler list file.

Usage: 20 bytes

7.2.3.3 Dynamic RAM usage

Dynamic RAM usage is the amount of RAM allocated by the driver at runtime.

Usage: 18 bytes

7.3 Encryption driver

This is an additional logical driver which can be used to protect the file system data against unauthorized access. The data is encrypted using a very efficient implementation of the Data Encryption Standard and of the Advanced Encryption Standard (AES) algorithm. AES algorithms are provided for 128-bit and 256-bit key lengths.

The logical driver can be used with both FAT and EFS file systems and with any supported storage device.

A separate volume is assigned to each driver instance. The volumes can be accessed using the following names: "crypt:0:", "crypt:1:", etc.

7.3.1 Theory of operation

The sector data is transformed to make it unreadable for anyone who tries to read it directly. The operation which makes the data unreadable is called encryption and is performed when the file system writes the sector data. When the content of a sector is read the reversed operation takes place which makes the data readable. This is called decryption. Both operations use a cryptographic algorithm and a key to transform the data. The same key is used for encryption and decryption. Without the knowledge of the key it is not possible to decrypt the data.

7.3.2 Configuring the driver

7.3.2.1 Runtime configuration

To add the driver, call `FS_AddDevice()` with the driver identifier set to `FS_CRYPT_Driver`. This function has to be called from within `FS_X_AddDevices()`. Refer to `FS_X_AddDevices()` for more information. The following table lists the API functions that can be called by the application to configure the driver.

Function	Description
<code>FS_CRYPT_Configure()</code>	Sets the working parameters of a driver instance.

7.3.2.1.1 FS_CRYPT_Configure()

Description

Sets the working parameters of a driver instance.

Prototype

```
void FS_CRYPT_Configure(
    U8 Unit,
    const FS_DEVICE_TYPE * pDeviceType,
    U8 DeviceUnit,
    const FS_CRYPT_ALGO_TYPE * pAlgoType,
    void * pContext,
    const U8 * pKey);
```

Parameters

Parameter	Description
Unit	Index of driver to be configured (0-based).
pDeviceType	in Device to access the storage medium.
DeviceUnit	Number of device to access the storage medium (0-based).
pAlgoType	in The type of encryption algorithm.
pContext	in Data specific to cryptographic algorithm.
pKey	in Password for data encryption/decryption.

Additional information

This function has to be called once for each driver instance. `pAlgoType` is a pointer to one of the following structures:

Algorithm type	Description
FS_CRYPT_ALGO_DES	Data Encryption Standard with 56-bit key length
FS_CRYPT_ALGO_AES128	Advanced Encryption Standard with 128-bit key length
FS_CRYPT_ALGO_AES256	Advanced Encryption Standard with 256-bit key length

`pContext` is passed to as parameter to the encryption and decryption routines via `pContext`. The memory region `pContext` points to has to remain valid from the moment the driver is configured until the `FS_DeInit()` function is called.

The number of bytes in `pKey` array has to match the size of the key required by the used cryptographic algorithm as follows:

Algorithm type	Size in bytes
FS_CRYPT_ALGO_DES	8
FS_CRYPT_ALGO_AES128	16
FS_CRYPT_ALGO_AES256	32

Example

```
#include "FS.h"

#define ALLOC_SIZE 2048 // Size of emFile memory pool

static U32 _aMemBlock[ALLOC_SIZE / 4];
static FS_AES_CONTEXT _Context;

/*****
 *
 * FS_X_AddDevices
 *
 * Function description
 *****/
```

```
*   This function is called by the FS during FS_Init().
*/
void FS_X_AddDevices(void) {
    U8 DeviceUnit;
    U8 PartIndex;
    U8 Unit;
    U8 aPass[16] = {'s', 'e', 'c', 'r', 'e', 't'};

    FS_AssignMemory(_aMemBlock, sizeof(_aMemBlock));
    //
    // Add SD/MMC card device driver.
    //
    DeviceUnit = 0;
    FS_AddPhysDevice(&FS_MMC_CM_Driver);
    FS_MMC_CM_Allow4bitMode(0, 1);
    //
    // Add the encryption driver. The storage can be accessed as volume "crypt:0:".
    //
    Unit = 0;
    FS_AddDevice(&FS_CRYPT_Driver);
    FS_CRYPT_Configure(Unit,
                       &FS_MMC_CM_Driver,
                       DeviceUnit,
                       &FS_CRYPT_ALGO_AES128,
                       &_Context,
                       aPass);
}
```

7.3.3 Performance and resource usage

7.3.3.1 ROM usage

The ROM usage depends on the compiler options, the compiler version and the used CPU. The memory requirements of the driver presented in the tables below were measured as described in the section *Test procedure* on page 1283.

Usage: 1.3 Kbytes

In addition, one of the following cryptographic algorithms is required:

Physical layer	Description	ROM [Kbytes]
FS_CRYPT_ALGO_DES	DES encryption algorithm.	3.2
FS_CRYPT_ALGO_AES128	AES encryption algorithm using an 128-bit key.	12.0
FS_CRYPT_ALGO_AES256	AES encryption algorithm using a 256-bit key.	12.0

7.3.3.2 Static RAM usage

Static RAM usage is the amount of RAM required by the driver for variables inside of the driver. The number of bytes can be seen in a compiler list file.

Usage: 24 bytes

7.3.3.3 Dynamic RAM usage

Dynamic RAM usage is the amount of RAM allocated by the driver at runtime. The amount required depends on the runtime configuration and on the selected encryption algorithm.

Every driver instance requires **16 bytes** of RAM. In addition, the context of the AES encryption algorithm requires **480 bytes** and that of the DES encryption algorithm **128 bytes** of RAM.

7.3.3.4 Performance

These performance measurements are in no way complete, but they give an approximation of the length of time required for common operations on various targets. The tests were performed as described in the section *Performance* on page 1289. All values are given in Kbytes/sec.

CPU type	Storage device	Write speed	Read speed
ST STM32F207 (96 MHz)	SD card as storage device using AES with an 128-bit key.	639	661
NXP Kinetis K60 (120 MHz)	NAND flash device interfaced via 8-bit bus using AES with an 128-bit key.	508	550

7.4 Sector Read-Ahead driver

The driver reads in advance more sectors than requested and caches them to provided buffer. The maximum number of sectors which fit in the buffer are read at once. If the requested sectors are present in the buffer the driver returns the cached sector contents and the storage medium is not accessed. The driver should be used on SD/MMC/eMMC storage devices where reading single sectors is less efficient than reading all the sectors at once. By default the driver is not active. The file system activates the driver when the allocation table is searched for free clusters. This will improve performance in the case where the whole allocation table needs to be scanned. To activate the support for read-ahead in the file system the `FS_SUPPORT_READ_AHEAD` define must be set to 1 in `FS_Conf.h`. The logical driver works with the FAT as well as with the EFS file system.

7.4.1 Configuring the driver

7.4.1.1 Runtime configuration

To add the driver, call `FS_AddDevice()` with the driver identifier set to `FS_READAHEAD_Driver`. This function has to be called from within `FS_X_AddDevices()`. Refer to `FS_X_AddDevices()` for more information. The following table lists the API functions that can be called by the application to configure the driver.

Function	Description
<code>FS_READAHEAD_Configure()</code>	Sets the parameters which allows the driver instance to access the storage medium.

7.4.1.1.1 FS_READAHEAD_Configure()

Description

Sets the parameters which allows the driver instance to access the storage medium.

Prototype

```
void FS_READAHEAD_Configure(
    U8 Unit,
    const FS_DEVICE_TYPE * pDeviceType,
    U8 DeviceUnit,
    U32 * pData,
    U32 NumBytes);
```

Parameters

Parameter	Description
Unit	Index of the driver instance (0-based)
pDeviceType	in Device driver used to access the storage device.
DeviceUnit	Index of the storage device (0-based)
pData	in Buffer to store the sector data read from storage device.
NumBytes	Number of bytes in the read buffer.

Additional information

This function is mandatory and it has to be called once for each instance of the driver. The read buffer has to be sufficiently large to store at least one logical sector.

Example

This example demonstrates how to configure the driver in order to access the data stored on an SD card.

```
#include "FS.h"

#define ALLOC_SIZE 2048 // Size of emFile memory pool
#define BUFFER_SIZE 4096

static U32 _aMemBlock[ALLOC_SIZE / 4];
static U32 _aReadBuffer[BUFFER_SIZE / 4];

/*****
 *
 * FS_X_AddDevices
 *
 * Function description
 * This function is called by the FS during FS_Init().
 */
void FS_X_AddDevices(void) {
    FS_AssignMemory(_aMemBlock, sizeof(_aMemBlock));
    //
    // Add SD/MMC card device driver.
    //
    FS_AddPhysDevice(&FS_MMC_CM_Driver);
    //
    // Add and configure the read-ahead driver. Volume name: "rah:0:"
    //
    FS_AddDevice(&FS_READAHEAD_Driver);
    FS_READAHEAD_Configure(0, &FS_MMC_CM_Driver, 0,
        _aReadBuffer, sizeof(_aReadBuffer));
}
```

7.4.2 Additional driver functions

The following table lists the API functions that can be called by the application at runtime to perform operations on the driver.

Function	Description
<code>FS_READAHEAD_GetStatCounters()</code>	Returns the values of the statistical counters.
<code>FS_READAHEAD_ResetStatCounters()</code>	Sets to 0 the values of all statistical counters.

7.4.2.1 FS_READAHEAD_GetStatCounters()

Description

Returns the values of the statistical counters.

Prototype

```
void FS_READAHEAD_GetStatCounters(U8 Unit,  
FS_READAHEAD_STAT_COUNTERS * pStat);
```

Parameters

Parameter	Description
Unit	Driver index (0-based)
pStat	out Values of statistical counters.

Additional information

This function is optional. The statistical counters are updated only when the file system is compiled with `FS_READAHEAD_ENABLE_STATS` set to 1 or with `FS_DEBUG_LEVEL` set to a value greater than or equal to `FS_DEBUG_LEVEL_CHECK_ALL`.

7.4.2.2 FS_READAHEAD_ResetStatCounters()

Description

Sets to 0 the values of all statistical counters.

Prototype

```
void FS_READAHEAD_ResetStatCounters(U8 Unit);
```

Parameters

Parameter	Description
<code>Unit</code>	Driver index (0-based)

Additional information

This function is optional. It is available only when the file system is compiled with `FS_READAHEAD_ENABLE_STATS` set to 1 or with `FS_DEBUG_LEVEL` set to a value greater than or equal to `FS_DEBUG_LEVEL_CHECK_ALL`.

7.4.2.3 FS_READAHEAD_STAT_COUNTERS

Type definition

```
typedef struct {  
    U32  ReadSectorCnt;  
    U32  ReadSectorCachedCnt;  
} FS_READAHEAD_STAT_COUNTERS;
```

Structure members

Member	Description
ReadSectorCnt	Internal use.
ReadSectorCachedCnt	Internal use.

7.4.3 Performance and resource usage

7.4.3.1 ROM usage

The ROM usage depends on the compiler options, the compiler version and the used CPU. The memory requirements of the driver presented in the tables below were measured as described in the section *Test procedure* on page 1283.

Usage: 1.4 Kbytes

7.4.3.2 Static RAM usage

Static RAM usage is the amount of RAM required by the driver for variables inside of the driver. The number of bytes can be seen in the compiler list file.

Usage: 20 bytes

7.4.3.3 Dynamic RAM usage

Dynamic RAM usage is the amount of RAM allocated by the driver at runtime.

Usage: 30 bytes

7.4.3.4 Performance

The detection of free space is 2 times faster when a 4KB read ahead buffer is used (measured on 4GB SD card formatted with 4KB clusters).

7.5 Sector Size Adapter driver

The logical driver supports access to a storage device using a sector size different than that of the underlying layer (typically a storage driver). The sector size of the logical driver is configurable and can be larger or smaller than the sector size of the below layer.

Typically, the logical driver is placed between the file system and a storage driver and it is configured with a sector size smaller than that of the storage layer to help reduce the RAM usage of the internal sector buffers of the file system.

7.5.1 Configuring the driver

To add the driver, call `FS_AddDevice()` with the driver identifier set to `FS_SECSIZE_Driver`. This function has to be called from within `FS_X_AddDevices()`. Refer to `FS_X_AddDevices()` for more information. The following table lists the API functions that can be called by the application to configure the driver.

Function	Description
<code>FS_SECSIZE_Configure()</code>	Sets the parameters of a driver instance.

7.5.1.1 FS_SECSIZE_Configure()

Description

Sets the parameters of a driver instance.

Prototype

```
void FS_SECSIZE_Configure(    U8          Unit,
                             const FS_DEVICE_TYPE * pDeviceType,
                             U8          DeviceUnit,
                             U16         BytesPerSector);
```

Parameters

Parameter	Description
Unit	Index of the driver instance (0-based).
pDeviceType	in Storage device.
DeviceUnit	Unit number of storage device.
BytesPerSector	Sector size in bytes presented to upper layer.

Additional information

This function is mandatory and it has to be called once for each instance of the driver. `BytesPerSector` has to be a power of 2 value.

Example

This example demonstrates how to configure the logical driver to access a NAND flash via the Universal NAND driver.

```
#include "FS.h"

#define ALLOC_SIZE 0x8000 // Size of emFile memory pool

static U32 _aMemBlock[ALLOC_SIZE / 4];

/*****
 *
 *      FS_X_AddDevices
 *
 *      Function description
 *      This function is called by the FS during FS_Init().
 */
void FS_X_AddDevices(void) {
    FS_AssignMemory(_aMemBlock, sizeof(_aMemBlock));
    //
    // Add NAND flash device driver.
    //
    FS_AddPhysDevice(&FS_NAND_UNI_Driver);
    FS_NAND_UNI_SetPhyType(0, &FS_NAND_PHY_ONFI);
    FS_NAND_UNI_SetECCHook(0, &FS_NAND_ECC_HW_NULL);
    //
    // Add sector conversion logical driver.
    //
    FS_AddDevice(&FS_SECSIZE_Driver);
    FS_SECSIZE_Configure(0, &FS_NAND_UNI_Driver, 0, 512);
}
```

7.5.2 Performance and resource usage

7.5.2.1 ROM usage

The ROM usage depends on the compiler options, the compiler version and the used CPU. The memory requirements of the driver presented in the tables below were measured as described in the section *Test procedure* on page 1283.

Usage: 1.1 Kbytes

7.5.2.2 Static RAM usage

Static RAM usage is the amount of RAM required by the driver for variables inside of the driver. The number of bytes can be seen in the compiler list file.

Usage: 20 bytes

7.5.2.3 Dynamic RAM usage

Dynamic RAM usage is the amount of RAM allocated by the driver at runtime.

Each driver instance requires **30 bytes** of RAM. In addition, a driver instance requires a working buffer of the size of one storage driver logical sector if the sector size of the storage driver is larger than the sector size configured for the logical driver configured via `FS_SECSIZE_Configure()`.

7.6 Sector Write Buffer driver

This driver was designed to help improve the write performance of the file system. It operates by temporarily storing the sector data to RAM which takes significantly less time than writing directly to a storage. The sector data is written later to storage at the request of the application or when the internal buffer is full. The sectors are written to storage in the same order in which they were written by the file system.

The advantages of using this driver are:

- a file system write operation blocks for a very short period of time.
- the number of write operations is reduced when the same sector is written in succession.
- the driver can be used with activated Journal since the write order is preserved. The internal buffer can be cleaned from application by calling the `FS_STORAGE_Sync()` API function. The function blocks until all sectors stored in the internal buffer are written to storage. Typically, this function should be called from a low priority task when the application does not access the file system.

7.6.1 Configuring the driver

7.6.1.1 Runtime configuration

To add the driver, call `FS_AddDevice()` with the driver identifier set to `FS_WRBUF_Driver`. This function has to be called from within `FS_X_AddDevices()`. Refer to `FS_X_AddDevices()` for more information. The following table lists the API functions that can be called by the application to configure the driver.

Function	Description
<code>FS_WRBUF_Configure()</code>	Sets the parameters of a driver instance.

7.6.1.1.1 FS_WRBUF_Configure()

Description

Sets the parameters of a driver instance.

Prototype

```
void FS_WRBUF_Configure(    U8          Unit,
                           const FS_DEVICE_TYPE * pDeviceType,
                           U8          DeviceUnit,
                           void        * pBuffer,
                           U32         NumBytes);
```

Parameters

Parameter	Description
Unit	Index of the driver instance (0-based).
pDeviceType	in Storage device.
DeviceUnit	Unit number of storage device.
pBuffer	in Storage for sector data.
NumBytes	Number of bytes in pBuffer.

Additional information

This function is mandatory and it has to be called once for each instance of the driver. FS_SIZEOF_WRBUF() can be used to calculate the number of bytes required to be allocated in order to store a specified number of logical sectors.

Example

This example demonstrates how to configure the logical driver to access an SD card via the SD/MMC card mode driver.

```
#include "FS.h"

#define ALLOC_SIZE 0x1000 // Size of emFile memory pool

static U32 _aMemBlock[ALLOC_SIZE / 4];
static U32 _aWriteBuffer[FS_SIZEOF_WRBUF(8, 512) / 4];

/*****
 *
 * FS_X_AddDevices
 *
 * Function description
 * This function is called by the FS during FS_Init().
 */
void FS_X_AddDevices(void) {
    FS_AssignMemory(_aMemBlock, sizeof(_aMemBlock));
    //
    // Add and configure the NOR flash driver.
    //
    FS_AddPhysDevice(&FS_MMC_CM_Driver);
    FS_MMC_CM_Allow4bitMode(0, 1);
    FS_MMC_CM_SetHWType(0, &FS_MMC_HW_CM_Default);
    //
    // Add and configure the write buffer driver.
    //
    FS_AddDevice(&FS_WRBUF_Driver);
    FS_WRBUF_Configure(0, &FS_MMC_CM_Driver, 0,
        _aWriteBuffer, sizeof(_aWriteBuffer));
}
```

7.6.1.1.2 Write buffer size

Description

Calculates the write buffer size.

Definition

```
#define FS_SIZEOF_WRBUF(NumSectors, BytesPerSector)
    ((FS_SIZEOF_WRBUF_SECTOR_INFO + (BytesPerSector)) * (NumSectors))
```

Symbols

Definition	Description
FS_SIZEOF_WR- BUF(NumSectors,	Calculates the write buffer size.

Additional information

This define can be used in an application to calculate the number of bytes that have to be allocated in order to store the specified number of logical sectors. `NumSectors` specifies the number of logical sectors while `BytesPerSector` the size of a logical sector in bytes.

7.6.2 Performance and resource usage

7.6.2.1 ROM usage

The ROM usage depends on the compiler options, the compiler version and the used CPU. The memory requirements of the driver presented in the tables below were measured as described in the section *Test procedure* on page 1283.

Usage: 1.2 Kbytes

7.6.2.2 Static RAM usage

Static RAM usage is the amount of RAM required by the driver for variables inside of the driver. The number of bytes can be seen in a compiler list file.

Usage: 20 bytes

7.6.2.3 Dynamic RAM usage

Dynamic RAM usage is the amount of RAM allocated by the driver at runtime.

Usage: 32 bytes

7.7 RAID1 driver

RAID1 is a logical file system driver that can be used to increase the integrity and reliability of the data saved on a storage device. This is realized by keeping a copy of all sector data on a separate partition also known as mirroring. When a read error occurs the data is recovered by reading it from the mirror partition.

7.7.1 Theory of operation

The logical driver uses a master and a mirror partition. On a file system write request, the sector data is written to both master and mirror partitions. On a file system read request, the logical driver tries to read the sector data from the master partition first. If a read error occurs, then the sector data is read from the mirror partition. This way the data is recovered and no error is reported to the file system.

The logical driver can be configured to store the sector data either on the same or on two separate storage devices, according to user requirements. If a single storage device is used, the first half is used as master partition. When using two different storage devices the size of the volumes does not have to be equal. The number of sectors available to the file system will be that of the smallest storage device. However, it is required that the sector size of both storage devices are equal. If necessary, the sector size can be adapted using the SECSIZE logical driver. For more information refer to *Sector Size Adapter driver* on page 1165.

7.7.2 NAND flash error recovery

The Universal NAND driver can make use of the RAID driver to avoid a data loss when an uncorrectable ECC error happens during a read operation. This feature is by default disabled and it can be enabled at compile time by setting the `FS_NAND_ENABLE_ERROR_RECOVERY` switch to 1 in `FS_Conf.h`.

7.7.3 Sector data synchronization

An unexpected reset that interrupts a write operation may lead to a data inconsistency. It is possible that the data of the last written sector is stored only to the master, but not to the mirror partition. After restart, the file system will continue to operate correctly but in case of a read error affecting this sector, old data is read from the mirror partition which may cause a data corruption. This situation can be prevented by synchronizing all the sectors on the RAID volume. The application can perform the synchronization by calling the `FS_STORAGE_SyncSectors()` API function. For example, a low priority task can call the function in parallel to other file system activities. For an example refer to `FS_RAID1_SetSyncBuffer()`.

7.7.4 Configuring the driver

7.7.4.1 Runtime configuration

The API functions listed in the next table can be used by the application to configure the behavior of the RAID1 driver. The application can call them only at the file system initialization in `FS_X_AddDevices()`.

Function	Description
<code>FS_RAID1_Configure()</code>	Configures the parameters of a driver instance.
<code>FS_RAID1_SetSectorRanges()</code>	Configures the position and the size of the RAID partitions.
<code>FS_RAID1_SetSyncBuffer()</code>	Sets a buffer for the synchronization operation.

Function	Description
<code>FS_RAID1_SetSyncSource()</code>	Specifies the source storage device for the synchronization operation.

7.7.4.1.1 FS_RAID1_Configure()

Description

Configures the parameters of a driver instance.

Prototype

```
void FS_RAID1_Configure(    U8          Unit,
                           const FS_DEVICE_TYPE * pDeviceType0,
                           U8          DeviceUnit0,
                           const FS_DEVICE_TYPE * pDeviceType1,
                           U8          DeviceUnit1);
```

Parameters

Parameter	Description
Unit	Index of the driver instance.
pDeviceType0	in Type of the primary (master) storage device.
DeviceUnit0	Index of the primary (master) storage device (0-based).
pDeviceType1	in Type of the secondary (mirror) storage device.
DeviceUnit1	Index of the secondary (mirror) storage device.

Additional information

This function has to be called once for each driver instance. The same storage device can be used both as primary and as secondary device in which case the first half is used as primary device the other half is used as secondary device.

Example

The following example shows how to configure RAID1 on a single volume.

```
#include "FS.h"

#define ALLOC_SIZE    0x8000          // Size of the memory pool in bytes

static U32 _aMemBlock[ALLOC_SIZE / 4]; // Memory pool used for
                                        // semi-dynamic allocation.

/*****
 *
 *    FS_X_AddDevices
 *
 *    Function description
 *    This function is called by the FS during FS_Init().
 */
void FS_X_AddDevices(void) {
    //
    // Give the file system some memory to work with.
    //
    FS_AssignMemory(&_aMemBlock[0], sizeof(_aMemBlock));
    //
    // Set the file system sector size.
    //
    FS_SetMaxSectorSize(2048);
    //
    // Add and configure the first NAND driver.
    //
    FS_AddDevice(&FS_NAND_UNI_Driver);
    FS_NAND_UNI_SetPhyType(0, &FS_NAND_PHY_ONFI);
    FS_NAND_UNI_SetECCHook(0, &FS_NAND_ECC_HW_NULL);
    //
    // Add and configure the RAID driver.
    //
    FS_AddDevice(&FS_RAID1_Driver);
    FS_RAID1_Configure(0, &FS_NAND_UNI_Driver, 0, &FS_NAND_UNI_Driver, 0);
}
```

```
}

```

The next example demonstrates how to configure a RAID1 on 2 separate volumes.

```
#include "FS.h"

#define ALLOC_SIZE      0x8000          // Size of the memory pool in bytes

static U32 _aMemBlock[ALLOC_SIZE / 4]; // Memory pool used for
                                        // semi-dynamic allocation.

/*****
 *
 *      FS_X_AddDevices
 *
 *      Function description
 *      This function is called by the FS during FS_Init().
 */
void FS_X_AddDevices(void) {
    //
    // Give the file system some memory to work with.
    //
    FS_AssignMemory(&_aMemBlock[0], sizeof(_aMemBlock));
    //
    // Set the file system sector size.
    //
    FS_SetMaxSectorSize(2048);
    //
    // Add and configure the NAND driver for the primary storage.
    //
    FS_AddDevice(&FS_NAND_UNI_Driver);
    FS_NAND_UNI_SetPhyType(0, &FS_NAND_PHY_ONFI);
    FS_NAND_UNI_SetECCHook(0, &FS_NAND_ECC_HW_NULL);
    //
    // Add and configure the NAND driver for the secondary storage.
    //
    FS_AddDevice(&FS_NAND_UNI_Driver);
    FS_NAND_UNI_SetPhyType(1, &FS_NAND_PHY_ONFI);
    FS_NAND_UNI_SetECCHook(1, &FS_NAND_ECC_HW_NULL);
    //
    // Add and configure the RAID driver.
    //
    FS_AddDevice(&FS_RAID1_Driver);
    FS_RAID1_Configure(0, &FS_NAND_UNI_Driver, 0, &FS_NAND_UNI_Driver, 1);
}

```

7.7.4.1.2 FS_RAID1_SetSectorRanges()

Description

Configures the position and the size of the RAID partitions.

Prototype

```
void FS_RAID1_SetSectorRanges(U8 Unit,
                              U32 NumSectors,
                              U32 StartSector0,
                              U32 StartSector1);
```

Parameters

Parameter	Description
Unit	Index of the driver instance (0-based).
NumSectors	Number of sectors in the partition.
StartSector0	Start sector of first partition (0-based).
StartSector1	Start sector of second partition (0-based).

Additional information

This function is optional. Per default, the RAID1 driver uses the entire available space of a storage device. The application can use `FS_RAID1_SetSectorRanges()` to specify areas of the primary and secondary storage devices the RAID1 driver has to use as storage.

Example

This example configures a RAID volume of 10000 sectors. The primary storage starts at sector index 0 and the secondary storage at sector index 10000.

```
#include "FS.h"

#define ALLOC_SIZE      0x8000          // Size of the memory pool in bytes

static U32 _aMemBlock[ALLOC_SIZE / 4]; // Memory pool used for
                                        // semi-dynamic allocation.
/*****
 *
 *      FS_X_AddDevices
 *
 *      Function description
 *      This function is called by the FS during FS_Init().
 */
void FS_X_AddDevices(void) {
    //
    // Give the file system some memory to work with.
    //
    FS_AssignMemory(&_aMemBlock[0], sizeof(_aMemBlock));
    //
    // Set the file system sector size.
    //
    FS_SetMaxSectorSize(2048);
    //
    // Add and configure the first NAND driver.
    //
    FS_AddDevice(&FS_NAND_UNI_Driver);
    FS_NAND_UNI_SetPhyType(0, &FS_NAND_PHY_ONFI);
    FS_NAND_UNI_SetECCHook(0, &FS_NAND_ECC_HW_NULL);
    //
    // Add and configure the RAID driver.
    //
    FS_AddDevice(&FS_RAID1_Driver);
    FS_RAID1_Configure(0, &FS_NAND_UNI_Driver, 0, &FS_NAND_UNI_Driver, 0);
    FS_RAID1_SetSectorRanges(0, 10000, 0, 10000);
}
```

7.7.4.1.3 FS_RAID1_SetSyncBuffer()

Description

Sets a buffer for the synchronization operation.

Prototype

```
void FS_RAID1_SetSyncBuffer(U8      Unit,
                           void * pBuffer,
                           U32     NumBytes);
```

Parameters

Parameter	Description
Unit	Index of the driver instance.
pBuffer	Pointer to a memory location to be used as buffer.
NumBytes	Number of bytes in the buffer.

Additional information

This function is optional. The configured buffer is used for when the sector data is synchronized between the primary and the secondary storage device via `FS_STORAGE_SyncSectors()`. The size of the buffer has to be sufficiently large to store at least two logical sectors otherwise the synchronization operation will fail. A larger buffer allows the driver to read and write multiple logical sectors at once which help increase the performance of the synchronization operation.

Example

The following example shows how to configure a synchronization buffer of 16KB and how to synchronize the RAID volume after an unexpected reset.

```
#include "FS.h"

#define ALLOC_SIZE      0x8000          // Size of the memory pool in bytes
#define BUFFER_SIZE    0x8000          // Size of the sync buffer in bytes

static U32 _aMemBlock[ALLOC_SIZE / 4]; // Memory pool used for
                                        // semi-dynamic allocation.
static U32 _aSyncBuffer[BUFFER_SIZE / 4]; // Buffer for the RAID synchronization.

/*****
 *
 *      FS_X_AddDevices
 *
 *      Function description
 *      This function is called by the FS during FS_Init().
 */
void FS_X_AddDevices(void) {
    //
    // Give the file system some memory to work with.
    //
    FS_AssignMemory(&_aMemBlock[0], sizeof(_aMemBlock));
    //
    // Set the file system sector size.
    //
    FS_SetMaxSectorSize(2048);
    //
    // Add and configure the first NAND driver.
    //
    FS_AddDevice(&FS_NAND_UNI_Driver);
    FS_NAND_UNI_SetPhyType(0, &FS_NAND_PHY_ONFI);
    FS_NAND_UNI_SetECCHook(0, &FS_NAND_ECC_HW_NULL);
    //
    // Add and configure the RAID driver.
    //
    FS_AddDevice(&FS_RAID1_Driver);
    FS_RAID1_Configure(0, &FS_NAND_UNI_Driver, 0, &FS_NAND_UNI_Driver, 0);
}
```

```
FS_RAID1_SetSyncBuffer(0, _aSyncBuffer, sizeof(_aSyncBuffer));
}

/*****
 *
 *      _SampleSyncRAID1
 *
 *  Function description
 *  Performs synchronization of the RAID1 partitions. This function may
 *  be called from a low-priority task in order to minimize the effect
 *  on the normal file system activity.
 */
static void _SampleSyncRAID1(void) {
    U32      iSector;
    FS_DEV_INFO DevInfo;
    //
    // Get the number of sectors on the storage.
    //
    FS_STORAGE_GetDeviceInfo("", &DevInfo);
    //
    // Synchronize one sector at a time to avoid
    // blocking the application for too long time.
    //
    for (iSector = 0; iSector < DevInfo.NumSectors; ++iSector) {
        FS_STORAGE_SyncSectors("", iSector, 1);
    }
}
```

7.7.4.1.4 FS_RAID1_SetSyncSource()

Description

Specifies the source storage device for the synchronization operation.

Prototype

```
void FS_RAID1_SetSyncSource(U8      Unit,
                           unsigned StorageIndex);
```

Parameters

Parameter	Description
Unit	Index of the driver instance.
StorageIndex	Index of the storage device to be used as source. <ul style="list-style-type: none"> • 0 - primary storage device. • 1 - secondary storage device.

Additional information

This function is optional. It can be used by an application to specify the storage device that has to be used as source when synchronizing the RAID1 partitions via `FS_STORAGE_SyncSectors()`. Per default the primary storage device is used as source.

Example

The following example shows how to use the secondary device as source for the synchronization operation.

```
#include "FS.h"

#define ALLOC_SIZE      0x8000          // Size of the memory pool in bytes
#define BUFFER_SIZE    0x8000          // Size of the sync buffer in bytes
#define NUM_SECTORS    2048            // Number of sectors on the RAM disk
#define BYTES_PER_SECTOR 512           // Size of a RAM disk sector
#define BASE_ADDR      0x80000000     // Address in memory of the first byte
// in the NOR flash

static U32 _aMemBlock[ALLOC_SIZE / 4]; // Memory pool used for
// semi-dynamic allocation.
static U32 _aRAMDisk[(NUM_SECTORS * BYTES_PER_SECTOR) / 4]; // Storage for RAM disk.
static U32 _aSyncBuffer[BUFFER_SIZE / 4]; // Buffer for the synchronization.

/*****
 *
 *      FS_X_AddDevices
 *
 *      Function description
 *      This function is called by the FS during FS_Init().
 *      It is supposed to add all devices, using primarily FS_AddDevice().
 *
 *      Note
 *      (1) Other API functions
 *          Other API functions may NOT be called, since this function is called
 *          during initialization. The devices are not yet ready at this point.
 */
void FS_X_AddDevices(void) {
    //
    // Give the file system some memory to work with.
    //
    FS_AssignMemory(&_aMemBlock[0], sizeof(_aMemBlock));
    //
    // Add and configure the RAM disk first for maximum read performance.
    //
    FS_AddDevice(&FS_RAMDISK_Driver);
    FS_RAMDISK_Configure(0, _aRAMDisk, BYTES_PER_SECTOR, NUM_SECTORS);
    //
    // Add and configure the driver for NOR flash.
    //
}
```

```
FS_AddDevice(&FS_NOR_BM_Driver);
FS_NOR_BM_SetPhyType(0, &FS_NOR_PHY_CFI_1x16);
FS_NOR_BM_Configure(0, BASE_ADDR, BASE_ADDR, BYTES_PER_SECTOR * NUM_SECTORS);
//
// Add and configure the RAID driver.
//
FS_AddDevice(&FS_RAID1_Driver);
FS_RAID1_Configure(0, &FS_RAMDISK_Driver, 0, &FS_NOR_BM_Driver, 0);
FS_RAID1_SetSyncBuffer(0, _aSyncBuffer, sizeof(_aSyncBuffer));
//
// Copy data from NOR flash to RAM disk when synchronizing at restart.
//
FS_RAID1_SetSyncSource(0, 1);
}
```

7.7.5 Performance and resource usage

7.7.5.1 ROM usage

The ROM usage depends on the compiler options, the compiler version and the used CPU. The memory requirements of the driver presented in the tables below were measured as described in the section *Test procedure* on page 1283.

Usage: 1.5 Kbytes

7.7.5.2 Static RAM usage

Static RAM usage is the amount of RAM required by the driver for variables inside of the driver. The number of bytes can be seen in a compiler list file.

Usage: 20 bytes

7.7.5.3 Runtime RAM usage

Runtime RAM usage is the amount of RAM allocated by the driver at runtime.

Usage: 48 bytes

7.8 RAID5 driver

RAID5 is a logical file system driver that can be used to increase the integrity and reliability of the data saved on a storage device. This is realized by keeping a parity check of the sector data of two or more consecutive sectors. In case of a read error the sector data is recovered the parity check information.

7.8.1 Theory of operation

RAID5 requires at least three storage partitions. Storage space equivalent to the size of one partition is used for parity check information, making it unavailable for data storage. Parity checking means adding an extra piece of information (a formula result) that can be used to replicate data in the case of a hardware defect or failure. The storage capacity required for the parity checking information can be reduced by increasing the number of partitions, thus increasing overall available capacity. The RAID5 add-on calculates the parity checking information using the "eXclusive Or" function (XOR). The result of an XOR function performed on any number of inputs is such that if one input is lost (i.e. one partition fails) the missing piece of information can be calculated (i.e. recovered or replicated) using the XOR result and the other known inputs.

7.8.2 NAND flash error recovery

The Universal NAND driver can make use of the RAID5 driver to avoid a data loss when an uncorrectable ECC error happens during a read operation. This feature is by default disabled and it can be enabled at compile time by setting the `FS_NAND_ENABLE_ERROR_RECOVERY` configuration define to 1 in `FS_Conf.h`.

7.8.3 Configuring the driver

7.8.3.1 Runtime configuration

The API functions listed in the next table can be used by the application to configure the behavior of the RAID5 driver. The application can call them only at the file system initialization in `FS_X_AddDevices()`.

Function	Description
<code>FS_RAID5_AddDevice()</code>	Configures a storage device for data storage.
<code>FS_RAID5_SetNumSectors()</code>	Specifies the number of logical sectors in a single RAID partition.
<code>FS_RAID5_GetOperatingMode()</code>	Returns the operating mode of the specified RAID5 partition.

7.8.3.1.1 FS_RAID5_AddDevice()

Description

Configures a storage device for data storage.

Prototype

```
void FS_RAID5_AddDevice(    U8          Unit,
                           const FS_DEVICE_TYPE * pDeviceType,
                           U8          DeviceUnit,
                           U32          StartSector);
```

Parameters

Parameter	Description
<code>Unit</code>	Index of the driver instance (0-based).
<code>pDeviceType</code>	in Type of storage device.
<code>DeviceUnit</code>	Index of the first storage device (0-based).
<code>StartSector</code>	Index of the first sector to be used for data storage (0-based).

Additional information

This function has to be called at least three times in `FS_X_AddDevices()` because the RAID5 logical driver requires at least three partitions for correct operation. One partition stores the parity check data while the the other partitions the payload. The partitions do not have to be located on different physical storage devices.

The number of logical sectors covered by a single parity check sector is one less than the total number of partitions added to the RAID5 logical driver. A configuration with one or two partitions is invalid and is reported as an error during the initialization of the RAID5 logical driver instance.

It is mandatory that all the configured partitions have the same logical sector size. If the configured partitions have different logical sector sizes, than the SECSIZE logical driver can be used to adapt them.

The RAID5 logical driver uses as storage the same number of logical sectors from each partition because the data is distributed equally between these partitions. Typically, the RAID5 logical driver uses the entire partition for data storage. This is the case when all configured partitions contain the same number of sectors. When the configured partitions have different number of sectors, then the RAID5 logical driver uses the number of logical sectors of the partition with smallest capacity. The number of logical sectors used by the RAID logical driver from each partition can be also explicitly configured via `FS_RAID5_SetNumSectors()`.

`StartSector` can be used to locate the RAID partition at other logical sector offset on the storage device than 0, when the first number of logical sectors on the partition are reserved for other purposes.

Example

The following code snippet shows how to configure a the RAID 5 add-on that uses three partitions located on the same NAND flash device.

```
#include "FS.h"
#include "FS_NAND_HW_Template.h"

#define ALLOC_SIZE      0x8000          // Size of the memory pool in bytes

static U32 _aMemBlock[ALLOC_SIZE / 4]; // Memory pool used for
                                        // semi-dynamic allocation.
/*****
*
```

```
*     FS_X_AddDevices
*
*   Function description
*     This function is called by the FS during FS_Init().
*/
void FS_X_AddDevices(void) {
    //
    // Give the file system some memory to work with.
    //
    FS_AssignMemory(&aMemBlock[0], sizeof(_aMemBlock));
    //
    // Add and configure the RAID5 volume. Volume name: "raid5:0:"
    //
    FS_AddDevice(&FS_RAID5_Driver);
    FS_RAID5_AddDevice(0, &FS_NAND_UNI_Driver, 0, 0);
    FS_RAID5_AddDevice(0, &FS_NAND_UNI_Driver, 0, 1000);
    FS_RAID5_AddDevice(0, &FS_NAND_UNI_Driver, 0, 2000);
    FS_RAID5_SetNumSectors(0, 1000);
    //
    // Add and configure the driver NAND driver. Volume name: "nand:0:"
    //
    FS_AddDevice(&FS_NAND_UNI_Driver);
    FS_NAND_UNI_SetPhyType(0, &FS_NAND_PHY_ONFI);
    FS_NAND_UNI_SetECCHook(0, &FS_NAND_ECC_HW_NULL);
    FS_NAND_ONFI_SetHWType(0, &FS_NAND_HW_Template);
}
```

7.8.3.1.2 FS_RAID5_SetNumSectors()

Description

Specifies the number of logical sectors in a single RAID partition.

Prototype

```
void FS_RAID5_SetNumSectors(U8 Unit,  
                             U32 NumSectors);
```

Parameters

Parameter	Description
<code>Unit</code>	Index of the driver instance (0-based).
<code>NumSectors</code>	Number of sectors in the RAID partition.

Additional information

This function is optional and can be called only from `FS_X_AddDevices()`. By default, the RAID5 logical driver uses all the logical sectors of a partition to store the data. `FS_RAID5_SetNumSectors()` can be used to configure a different value for the number of logical sectors when for example the end of a partition is reserved and cannot be used for data storage.

7.8.3.1.3 FS_RAID5_GetOperatingMode()

Description

Returns the operating mode of the specified RAID5 partition.

Prototype

```
int FS_RAID5_GetOperatingMode(U8 Unit);
```

Parameters

Parameter	Description
<code>Unit</code>	Index of the driver instance (0-based).

Return value

- ≥ 0 Operating mode.
- < 0 An error occurred.

Additional information

This function is optional and can be called from an application to get the operating mode of the RAID5 logical driver. The RAID5 logical driver can operate in one of the following modes:

- `FS_RAID_OPERATING_MODE_NORMAL` All storage devices are present and are operating normally.
- `FS_RAID_OPERATING_MODE_DEGRADED` One storage device is not operating properly.
- `FS_RAID_OPERATING_MODE_FAILURE` Two or more storage devices are not operating properly.

7.8.3.1.4 RAID operating modes

Description

Operating modes of a RAID logical driver.

Definition

```
#define FS_RAID_OPERATING_MODE_NORMAL      0
#define FS_RAID_OPERATING_MODE_DEGRADED   1
#define FS_RAID_OPERATING_MODE_FAILURE    2
```

Symbols

Definition	Description
FS_RAID_OPERATING_MODE_NORMAL	All storage devices present and operating normally.
FS_RAID_OPERATING_MODE_DEGRADED	One storage device is not operating properly.
FS_RAID_OPERATING_MODE_FAILURE	Two or more storage devices are not operating properly.

Additional information

The operating mode of RAID5 logical driver can be queried via the `FS_RAID5_GetOperatingMode()` API function.

7.8.4 Performance and resource usage

7.8.4.1 ROM usage

The ROM usage depends on the compiler options, the compiler version and the used CPU. The memory requirements of the driver presented in the tables below were measured as described in the section *Test procedure* on page 1283.

Usage: 2.2 Kbytes

7.8.4.2 Static RAM usage

Static RAM usage is the amount of RAM required by the driver for variables inside of the driver. The number of bytes can be taken from the compiler list file.

Usage: 30 bytes

7.8.4.3 Dynamic RAM usage

Dynamic RAM usage is the amount of RAM allocated by the driver at runtime.

Each driver instance requires **23 bytes** of RAM. In addition, **11 bytes** of RAM are required for each different storage device used by the RAID5 driver instance and **12 bytes** for each configured partition.

7.9 Logical Volume driver

This driver can be used by an application to create a volume that extents over two or more existing volumes. In addition, the Logical Volume driver can also be configured to create a volume using as storage only a specified sector range of an already existing volume. The volumes created via the Logical Volume driver can be accessed by the application in the same way as any other volume attached to a device or logical driver. The type of the storage device attached to the volumes combined via the Logical Volume driver is not relevant as long as they have the same logical sector size. The combined volumes can be attached to device as well as logical drivers.

The Logical Volume driver is included in the LOGVOL component that also provides the implementation of the `FS_LOGVOL_Create()` and `FS_LOGVOL_AddDevice()` API functions. These functions were the only way for creating logical volumes in emFile versions older than 5.x. The functionality provided by the Logical Volume driver is similar to the functionality of the API functions `FS_LOGVOL_Create()` and `FS_LOGVOL_AddDevice()`. The difference is that the volume created using the later method is not attached to a driver and as a consequence the volume cannot be used with any of the logical drivers for example to encrypt its contents via the *Encryption driver* on page 1154. Therefore SEGGER recommends the Logical Volume driver as the preferred method of creating logical volumes.

The volume attached to a Logical Volume driver has a fixed name as described in the section *General information* on page 1149. If the application wishes to access the volume under a different name then it can do so by configuring an alias for the volume name via `FS_SetVolumeAlias()`.

7.9.1 Configuring the driver

The Logical Volume driver has to be configured at compile time and at runtime. This section describes how this can be realized.

7.9.1.1 Compile time configuration

The next table lists the available configuration defines followed by a detailed description of them. The configuration defines must be added to the `FS_Conf.h` file which is the main configuration file of emFile. For detailed information about the configuration of emFile and of the configuration define types, refer to *Configuration of emFile* on page 1218

Define	Default value	Type	Description
<code>FS_LOGVOL_NUM_UNITS</code>	4	N	Maximum number of driver instances.
<code>FS_LOGVOL_SUPPORT_CLEAN</code>	1	B	Enables or disables the support for executing the garbage collection in the application.
<code>FS_LOGVOL_SUPPORT_DRIVER_MODE</code>	0	B	Configures the working mode of the driver.
<code>FS_LOGVOL_SUPPORT_TRIM</code>	1	B	Enables or disables the support for marking logical sectors are not being in use.

7.9.1.1.1 FS_LOGVOL_NUM_UNITS

This define specifies the maximum number of driver instances an application is allowed create. Four bytes of static RAM are reserved for each driver instance. If the maximum number of driver instances is smaller than the default then `FS_LOGVOL_NUM_UNITS` can be set to the to that value in order to reduce the RAM usage.

7.9.1.1.2 FS_LOGVOL_SUPPORT_CLEAN

This define specifies if the application is allowed to perform a garbage collection operation via the LOGVOL driver. If `FS_LOGVOL_SUPPORT_CLEAN` is set to 1 then the applica-

tion can perform a garbage collection operation via `FS_STORAGE_Clean()` and `FS_STORAGE_CleanOne()` on the device configured as data storage. If the used storage device does not support garbage collection then `FS_NOR_SUPPORT_CLEAN` can be safely set to 0 in order to reduce the ROM usage.

7.9.1.1.3 FS_LOGVOL_SUPPORT_DRIVER_MODE

`FS_LOGVOL_SUPPORT_DRIVER_MODE` can be used to configure if the LOGVOL component works in legacy or driver mode. By default the component works in legacy mode which means that the application has to use the functions `FS_LOGVOL_Create()` and `FS_LOGVOL_AddDevice()` to configure a volume. If `FS_LOGVOL_SUPPORT_DRIVER_MODE` is set to 1 then the LOGVOL component works in driver mode. In this mode the LOGVOL component behaves like any other logical driver in that an instance of the driver can be added to the file system via `FS_AddDevice()`. Each instance of the Logical Volume driver must be configured at runtime by calling `FS_LOGVOL_AddDeviceEx()` in `FS_X_AddDevice()`.

7.9.1.1.4 FS_LOGVOL_SUPPORT_TRIM

`FS_LOGVOL_SUPPORT_TRIM` can be used to enable or disable the handling of file system operations that inform a device driver about logical sectors that are no longer in use. A device driver can use this information to optimize the internal operation that copies the data from one physical location to another by not copying the contents of the logical sectors that are marked as being no longer in use. Enabling this feature increases the ROM usage of the LOGVOL driver.

7.9.1.2 Runtime configuration

The Logical Volume driver has to be added to the file system by calling `FS_AddDevice()` in `FS_X_AddDevices()` with the driver identifier set to `FS_LOGVOL_Driver`. Refer to `FS_X_AddDevices()` for more information. The following table lists the API functions that can be called by the application to configure the driver.

Function	Description
<code>FS_LOGVOL_AddDeviceEx()</code>	Adds a storage device to a logical volume.

7.9.1.2.1 FS_LOGVOL_AddDeviceEx()

Description

Adds a storage device to a logical volume.

Prototype

```
int FS_LOGVOL_AddDeviceEx(    U8          Unit,
                             const FS_DEVICE_TYPE * pDeviceType,
                             U8          DeviceUnit,
                             U32        StartSector,
                             U32        NumSectors);
```

Parameters

Parameter	Description
<code>Unit</code>	Index of the driver instance (0-based).
<code>pDeviceType</code>	Type of the storage device that has to be added.
<code>DeviceUnit</code>	Index of the storage device that has to be added (0-based).
<code>StartSector</code>	Index of the first sector that has to be used as storage (0-based).
<code>NumSectors</code>	Number of sectors that have to be used as storage.

Return value

= 0 OK, storage device added.
 ≠ 0 An error occurred.

Additional information

This function has to be called at least once for each instance of a LOGVOL driver. Each call to `FS_LOGVOL_AddDeviceEx()` defines a range of sectors to be used as storage from a volume attached to a device or logical driver. The volume to be used as storage is identified by `pDeviceType` and `DeviceUnit`. If the defined logical volume extends over two or more existing sectors then all of these volumes need to have the same logical sector size.

If `NumSectors` is set to 0 then all the sectors of the specified volume are used as storage.

`FS_LOGVOL_AddDeviceEx` does nothing if `FS_LOGVOL_SUPPORT_DRIVER_MODE` is set to 0.

Example

The following example demonstrates how to configure the logical driver to use as storage only a sector range of an SD card via the SD/MMC card mode driver. The application can access the volume under the name "sdcard".

```
#include "FS.h"
#include "FS_MMC_HW_CM_Template.h"

#define ALLOC_SIZE          0x2000          // Size of emFile memory pool
#define START_SECTOR       0                // Index of the first sector to be used.
#define NUM_SECTORS        10000           // Number of sectors in the LOGVOL volume.

static U32 _aMemBlock[ALLOC_SIZE / 4];    // emFile memory pool.

/*****
 *
 *      FS_X_AddDevices
 *
 *      Function description
 *      This function is called by the FS during FS_Init().
 */
void FS_X_AddDevices(void) {
    //
    // Give file system memory to work with.
```

```

//
FS_AssignMemory(_aMemBlock, sizeof(_aMemBlock));
//
// Add SD/MMC card device driver but do not attach any volume to it.
//
FS_AddPhysDevice(&FS_MMC_CM_Driver);
FS_MMC_CM_Allow4bitMode(0, 1);
FS_MMC_CM_AllowHighSpeedMode(0, 1);
FS_MMC_CM_SetHWType(0, &FS_MMC_HW_CM_Template);
//
// Add and configure the logical volume. Volume name: "sdcard".
//
#if FS_LOGVOL_SUPPORT_DRIVER_MODE
    FS_AddDevice(&FS_LOGVOL_Driver);
    FS_LOGVOL_AddDeviceEx(0, &FS_MMC_CM_Driver, 0, START_SECTOR, NUM_SECTORS);
#endif // FS_LOGVOL_SUPPORT_DRIVER_MODE
#if (FS_MAX_LEN_VOLUME_ALIAS > 0)
    FS_SetVolumeAlias("lvol:0:", "sdcard");
#endif // FS_MAX_LEN_VOLUME_ALIAS > 0
}

```

This next example demonstrates how to configure the logical driver to use as storage volumes attached to a NAND and NOR flash device.

```

#include "FS.h"
#include "FS_NAND_HW_Template.h"
#include "FS_NOR_HW_SPIFI_Template.h"

#define ALLOC_SIZE          0x4000          // Size of emFile memory pool
#define BYTES_PER_SECTOR   2048           // Number of bytes in a logical sector.

static U32 _aMemBlock[ALLOC_SIZE / 4];    // emFile memory pool.

/*****
 *
 *      FS_X_AddDevices
 *
 *      Function description
 *      This function is called by the FS during FS_Init().
 */
void FS_X_AddDevices(void) {
    //
    // Give file system memory to work with.
    //
    FS_AssignMemory(_aMemBlock, sizeof(_aMemBlock));
    //
    // Configure the size of the logical sector and activate the file buffering.
    //
    FS_SetMaxSectorSize(BYTES_PER_SECTOR);
    //
    // Add and configure the Universal NAND driver.
    //
    FS_AddPhysDevice(&FS_NAND_UNI_Driver);
    FS_NAND_UNI_SetPhyType(0, &FS_NAND_PHY_ONFI);
    FS_NAND_UNI_SetECCHook(0, &FS_NAND_ECC_HW_NULL);
    FS_NAND_ONFI_SetHWType(0, &FS_NAND_HW_Template);
    //
    // Add and configure the NOR driver.
    //
    FS_AddPhysDevice(&FS_NOR_BM_Driver);
    FS_NOR_BM_SetPhyType(0, &FS_NOR_PHY_SPIFI);
    FS_NOR_BM_Configure(0, 0x80000000, 0x80000000, 0x01000000);
    FS_NOR_BM_SetSectorSize(0, BYTES_PER_SECTOR);
    FS_NOR_SPIFI_Allow2bitMode(0, 1);
    FS_NOR_SPIFI_Allow4bitMode(0, 1);
    FS_NOR_SPIFI_SetHWType(0, &FS_NOR_HW_SPIFI_Template);
#if FS_LOGVOL_SUPPORT_DRIVER_MODE
    //
    // Add and configure the logical volume.
    // The entire storage space of the NAND and NOR device is used.
    // Volume name: "lvol:0:".
    //
    FS_AddDevice(&FS_LOGVOL_Driver);
    FS_LOGVOL_AddDeviceEx(0, &FS_NAND_UNI_Driver, 0, 0, 0);
    FS_LOGVOL_AddDeviceEx(0, &FS_NOR_BM_Driver, 0, 0, 0);
#endif
}

```



```
#endif // FS_LOGVOL_SUPPORT_DRIVER_MODE  
}
```

7.9.2 Performance and resource usage

7.9.2.1 ROM usage

The ROM usage depends on the compiler options, the compiler version and the used CPU. The memory requirements of the driver presented in the tables below were measured as described in the section *Test procedure* on page 1283.

Usage: 1.0 Kbytes

7.9.2.2 Static RAM usage

Static RAM usage is the amount of RAM required by the driver for variables inside of the driver. The number of bytes can be seen in a compiler list file.

Usage: 24 bytes

7.9.2.3 Dynamic RAM usage

Dynamic RAM usage is the amount of RAM allocated by the driver at runtime.

Usage: 6 bytes for each driver instance + **21 bytes** for each sector range defined via `FS_LOGVOL_AddDeviceEx()`.

Chapter 8

Custom drivers

This chapter describes how to implement a custom device or logical driver.

8.1 General information

emFile comes with device drivers that support all of the popular storage devices such as NAND flash, NOR flash and SD card. However, using a storage device that is not supported by emFile may require the implementation of a custom device driver. In addition, the functionality of the file system may be extended by implementing a custom logical driver. The following sections describe which functions are required to be implemented and how the custom device or logical driver can be used with emFile.

8.2 Driver layer API

This section describes the functions of a device or logical driver. The API of the driver layer is implemented as a structure of type `FS_DEVICE_TYPE` that contains pointers to functions.

Note

The actual names of these functions are not relevant because the file system accesses them via the function table.

8.2.1 FS_DEVICE_TYPE

Type definition

```
typedef struct {
    FS_DEVICE_TYPE_GET_NAME      * pfGetName;
    FS_DEVICE_TYPE_ADD_DEVICE    * pfAddDevice;
    FS_DEVICE_TYPE_READ          * pfRead;
    FS_DEVICE_TYPE_WRITE         * pfWrite;
    FS_DEVICE_TYPE_IOCTL         * pfIoctl;
    FS_DEVICE_TYPE_INIT_MEDIUM   * pfInitMedium;
    FS_DEVICE_TYPE_GET_STATUS    * pfGetStatus;
    FS_DEVICE_TYPE_GET_NUM_UNITS * pfGetNumUnits;
} FS_DEVICE_TYPE;
```

Structure members

Member	Description
pfGetName	Returns the name of the driver.
pfAddDevice	Creates a new driver instance.
pfRead	Reads sector data.
pfWrite	Writes sector data.
pfIoctl	Executes command.
pfInitMedium	Initializes the storage device.
pfGetStatus	Returns presence status of the storage device.
pfGetNumUnits	Returns the number of driver instances.

8.2.2 FS_DEVICE_TYPE_GET_NAME

Description

Returns the driver name.

Type definition

```
typedef const char * FS_DEVICE_TYPE_GET_NAME(U8 Unit);
```

Parameters

Parameter	Description
<code>Unit</code>	Index of the driver instance (0-based).

Return value

Name of the driver as 0-terminated string.

Additional information

The returned name is used by the file system to create the volume name. The name must be unique between all device and logical drivers configured by the application.

8.2.3 FS_DEVICE_TYPE_ADD_DEVICE

Description

Initializes a new driver instance.

Type definition

```
typedef int FS_DEVICE_TYPE_ADD_DEVICE(void);
```

Return value

≥ 0 OK, index of the created driver instance.
< 0 An error occurred.

Additional information

This is the first function called by the file system. Typically, it is called from `FS_AddDevice()` or `FS_AddPhysDevice()` at the file system initialization.

8.2.4 FS_DEVICE_TYPE_READ

Description

Reads one or more logical sectors from storage device.

Type definition

```
typedef int FS_DEVICE_TYPE_READ(U8      Unit,
                                U32     SectorIndex,
                                void *  pBuffer,
                                U32     NumSectors);
```

Parameters

Parameter	Description
Unit	Index of the driver instance (0-based).
SectorIndex	First logical sector to be read from the device.
pData	Pointer to buffer that receives the sector data.
NumSectors	Number of logical sectors to be read.

Return value

= 0 OK, data successfully read.
 ≠ 0 An error occurred.

Additional information

The sector data has to be stored at the following bytes offsets in [pData](#):

Byte offset	Logical sector index
0	SectorIndex
BytesPerSector	SectorIndex + 1
BytesPerSector * 2	SectorIndex + 2
BytesPerSector * 3	SectorIndex + 3
...	...
BytesPerSector * (NumSectors - 1)	SectorIndex + (NumSectors - 1)

8.2.5 FS_DEVICE_TYPE_WRITE

Description

Writes one or more logical sectors to storage device.

Type definition

```
typedef int FS_DEVICE_TYPE_WRITE(
    U8      Unit,
    U32     SectorIndex,
    const void * pBuffer,
    U32     NumSectors,
    U8      RepeatSame);
```

Parameters

Parameter	Description
<code>Unit</code>	Index of the driver instance (0-based).
<code>SectorIndex</code>	First sector to be written to the device.
<code>pData</code>	Pointer to buffer containing the sector data to be written.
<code>NumSectors</code>	Number of logical sectors to write.
<code>RepeatSame</code>	Specifies how the sector data has to be written <ul style="list-style-type: none"> • 0 - Different data is stored to each sector. • 1 - Same data is stored to all sectors.

Return value

= 0 OK, data successfully written.
 ≠ 0 An error occurred.

Additional information

The sector data is stored at the following bytes offsets in `pData` if `RepeatSame` is set to 0:

Byte offset	Logical sector index
0	<code>SectorIndex</code>
<code>BytesPerSector</code>	<code>SectorIndex + 1</code>
<code>BytesPerSector * 2</code>	<code>SectorIndex + 2</code>
<code>BytesPerSector * 3</code>	<code>SectorIndex + 3</code>
...	...
<code>BytesPerSector * (NumSectors - 1)</code>	<code>SectorIndex + (NumSectors - 1)</code>

If `RepeatSame` is set to 1 then `pData` points to a memory region that is `BytePerSector` bytes large. This block of data has to be stored repeatedly to the logical sector indexes `SectorIndex` to `SectorIndex + (NumSectors - 1)`

8.2.6 FS_DEVICE_TYPE_IOCTL

Description

Executes driver command.

Type definition

```
typedef int FS_DEVICE_TYPE_IOCTL(U8      Unit,
                                I32      Cmd,
                                I32      Aux,
                                void *  pBuffer);
```

Parameters

Parameter	Description
Unit	Index of the driver instance (0-based).
Cmd	Command to be executed.
Aux	Command parameter.
pBuffer	in Command parameter. out Command response.

Return value

≥ 0 OK, command executed successfully.
 < 0 An error occurred.

Additional information

[Cmd](#) can be one of the codes listed in *I/O command codes* on page 1209. [Aux](#) and [pBuffer](#) are optional parameters to the command. [pBuffer](#) is used by some of the commands to return a value to the caller.

8.2.7 FS_DEVICE_TYPE_INIT_MEDIUM

Description

Initializes the storage device.

Type definition

```
typedef int FS_DEVICE_TYPE_INIT_MEDIUM(U8 Unit);
```

Parameters

Parameter	Description
<code>Unit</code>	Index of the driver instance (0-based).

Return value

= 0 OK, storage device initialized.
≠ 0 An error occurred.

Additional information

This function is typically called when formatting or mounting a storage device.

8.2.8 FS_DEVICE_TYPE_GET_STATUS

Description

Returns the presence status of the storage device.

Type definition

```
typedef int FS_DEVICE_TYPE_GET_STATUS(U8 Unit);
```

Parameters

Parameter	Description
<code>Unit</code>	Index of the driver instance (0-based).

Return value

`FS_MEDIA_STATE_UNKNOWN` The state of the media is unknown. `FS_MEDIA_NOT_PRESENT` No card is present. `FS_MEDIA_IS_PRESENT` If a card is present.

Additional information

This function is relevant only for drivers that access a removable storage device such as an SD card. For other storage devices or for a logical driver this function can simply return `FS_MEDIA_IS_PRESENT`.

8.2.9 FS_DEVICE_TYPE_GET_NUM_UNITS

Description

Returns the number of driver instances.

Type definition

```
typedef int FS_DEVICE_TYPE_GET_NUM_UNITS(void);
```

Return value

- ≥ 0 Number of driver instances.
- < 0 An error occurred.

8.2.10 FS_ON_READ_ERROR_CALLBACK

Description

The function is called when a driver encounters an error while reading sector data.

Type definition

```
typedef int FS_ON_READ_ERROR_CALLBACK(const FS_DEVICE_TYPE * pDeviceType,
                                     U32 DeviceUnit,
                                     U32 SectorIndex,
                                     void * pBuffer,
                                     U32 NumSectors);
```

Parameters

Parameter	Description
<code>pDeviceType</code>	Type of storage device which encountered the read error.
<code>DeviceUnit</code>	Unit number of the storage device where the read error occurred.
<code>SectorIndex</code>	Index of the sector where the read error occurred.
<code>pBuffer</code>	<code>out</code> Corrected sector data.
<code>NumSectors</code>	Number of sectors on which the read error occurred.

Return value

= 0 OK, sector data returned.
 ≠ 0 An error occurred.

Additional information

Typically, called by the NAND driver to get corrected sector data when a bit error occurs.

8.2.11 FS_READ_ERROR_DATA

Description

Data passed as parameter to the `FS_CMD_SET_READ_ERROR_CALLBACK` command.

Type definition

```
typedef struct {  
    FS_ON_READ_ERROR_CALLBACK * pfCallback;  
} FS_READ_ERROR_DATA;
```

Structure members

Member	Description
<code>pfCallback</code>	Function to be called on a read error.

Additional information

This structure is passed via `pBuffer` to `FS_DEVICE_TYPE_IOCTL`.

8.2.12 I/O command codes

Description

Command codes sent by the file system to device and logical drivers.

Definition

```
#define FS_CMD_REQUIRES_FORMAT          1003
#define FS_CMD_GET_DEVINFO              1004
#define FS_CMD_FORMAT_LOW_LEVEL         1005
#define FS_CMD_FREE_SECTORS             1006
#define FS_CMD_SET_DELAY                 1007
#define FS_CMD_UNMOUNT                  1008
#define FS_CMD_UNMOUNT_FORCED           1009
#define FS_CMD_SYNC                      1010
#define FS_CMD_DEINIT                   1011
#define FS_CMD_CLEAN_ONE                 1012
#define FS_CMD_CLEAN                     1013
#define FS_CMD_GET_SECTOR_USAGE          1014
#define FS_CMD_ENABLE_READ_AHEAD        1015
#define FS_CMD_DISABLE_READ_AHEAD       1016
#define FS_CMD_GET_CLEAN_CNT             1017
#define FS_CMD_SET_READ_ERROR_CALLBACK   1018
#define FS_CMD_SYNC_SECTORS              1019
```

Symbols

Definition	Description
FS_CMD_REQUIRES_FOR- MAT	Checks if the storage device is low-level formatted.
FS_CMD_GET_DEVINFO	Returns information about the storage device.
FS_CMD_FOR- MAT_LOW_LEVEL	Performs a low-level format operation.
FS_CMD_FREE_SECTORS	Informs the driver about unused logical sectors.
FS_CMD_SET_DELAY	Configures an access delay.
FS_CMD_UNMOUNT	Invalidates all information about the storage device.
FS_CMD_UNMOUNT_FORCED	Invalidates all information about the storage device.
FS_CMD_SYNC	Request the driver to write any cached information to the storage device.
FS_CMD_DEINIT	Frees all resources allocated by all the driver instances.
FS_CMD_CLEAN_ONE	Requests the driver to perform one clean operation.
FS_CMD_CLEAN	Requests the driver to completely clean the storage device.
FS_CMD_GET_SEC- TOR_USAGE	Queries the driver about the usage of a logical sector.
FS_CMD_ENABLE_READ_A- HEAD	Requests the driver to start reading sectors in advance.
FS_CMD_DISABLE_READ_A- HEAD	Requests the driver to stop reading sectors in advance.
FS_CMD_GET_CLEAN_CNT	Returns the number of operations required to completely clean the storage device.
FS_CMD_SET_READ_ER- ROR_CALLBACK	Registers a handler for sector read errors.
FS_CMD_SYNC_SECTORS	Informs the driver about the sectors that must be synchronized.

Additional information

`FS_CMD_GET_DEVINFO` is mandatory to be implemented. In addition, the driver implementation has to return 0 in response to `FS_CMD_FREE_SECTORS` if it does not implement this command. The other commands are optional and the driver is permitted to return -1 if it does not implement them.

`FS_CMD_REQUIRES_FORMAT` and `FS_CMD_FORMAT_LOW_LEVEL` must be implemented by any device driver that uses a storage device which has to be initialize once before use. `FS_CMD_FORMAT_LOW_LEVEL` is used by `FS_FormatLow()`.

`FS_CMD_SET_DELAY` is used only by the FS simulation to test the RAM Disk driver.

The handling of `FS_CMD_UNMOUNT` and `FS_CMD_UNMOUNT_FORCED` has to invalidate any cached information related to the storage device.

The handling of `FS_CMD_SYNC` must write any dirty cached sector data to the storage device.

`FS_CMD_DEINIT` has to be handled only if the driver allocates dynamic memory and only when the file system is built with `FS_SUPPORT_DEINIT` set to 1.

The following tables details the usage of the `Aux` and `pBuffer` parameters specified in the call to `FS_DEVICE_TYPE_IOCTL` for each command code as well as the meaning of the return value. The commands that are not specified in a table do not make use of that parameter.

Cmd	Aux
<code>FS_CMD_FREE_SECTORS</code>	Index of the first unused logical sector.
<code>FS_CMD_SET_DELAY</code>	Read delay in milliseconds.
<code>FS_CMD_GET_SECTOR_USAGE</code>	Index of the logical sector to be queried.
<code>FS_CMD_SYNC_SECTORS</code>	Index of the first logical sector to be synchronized.

Cmd	pBuffer (input)
<code>FS_CMD_FREE_SECTORS</code>	Number of logical sectors as pointer to U32 value.
<code>FS_CMD_SET_DELAY</code>	Write delay in milliseconds as an int value.
<code>FS_CMD_SET_READ_ERROR_CALLBACK</code>	Handling function as pointer to a <code>FS_READ_ERROR_DATA</code> structure.
<code>FS_CMD_SYNC_SECTORS</code>	Number of logical sectors as pointer to U32 value.

Cmd	pBuffer (output)
<code>FS_CMD_GET_DEVINFO</code>	Device information as pointer to a <code>FS_DEV_INFO</code> structure.
<code>FS_CMD_CLEAN_ONE</code>	Indicates if more operations are required as pointer to int: =0 - the next command does nothing, =1 - the next command performs a clean operation.
<code>FS_CMD_GET_SECTOR_USAGE</code>	Sector usage a pointer to int: =0 - sector in use, =1 - sector not used, =2 - unknown usage
<code>FS_CMD_GET_CLEAN_CNT</code>	Number of <code>FS_CMD_CLEAN_ONE</code> commands required to completely clean the storage device as pointer to int.

Cmd	Return value
<code>FS_CMD_REQUIRES_FORMAT</code>	=1 - low-level format required, =0 - storage device is low-level formatted, < 0 - An error occurred.
<code>FS_CMD_GET_DEVINFO</code>	=0 - OK, operation succeeded, < 0 - An error occurred.
<code>FS_CMD_FORMAT_LOW_LEVEL</code>	=0 - OK, operation succeeded, < 0 - An error occurred.
<code>FS_CMD_FREE_SECTORS</code>	=0 - OK, operation succeeded, < 0 - An error occurred.
<code>FS_CMD_SET_DELAY</code>	=0 - OK, operation succeeded, < 0 - An error occurred.

Cmd	Return value
FS_CMD_CLEAN_ONE	=0 - OK, operation succeeded, < 0 - An error occurred.
FS_CMD_CLEAN	=0 - OK, operation succeeded, < 0 - An error occurred.
FS_CMD_GET_SEC- TOR_USAGE	=0 - OK, operation succeeded, < 0 - An error occurred.
FS_CMD_GET_CLEAN_CNT	=0 - OK, operation succeeded, < 0 - An error occurred.
FS_CMD_SYNC_SECTORS	=0 - OK, operation succeeded, < 0 - An error occurred.

8.3 Template implementation

The following template implementation can be used as a starting point for the implementation of a new device or logical driver. The implementation is included in the emFile shipment in the Sample/FS/Driver/Template folder.

```

/*****
*
*          (c) SEGGER Microcontroller GmbH
*          The Embedded Experts
*          www.segger.com
*
*****/

----- END-OF-HEADER -----

File      : TEMPLATE_Driver.c
Purpose   : Template for a FS driver.
*/

/*****
*
*          #include Section
*
*****/
#include "FS_Int.h"

/*****
*
*          Defines, configurable
*
*****/
#ifndef FS_TEMPLATE_NUM_UNITS
#define FS_TEMPLATE_NUM_UNITS 4 // Maximum number of driver instances.
#endif

/*****
*
*          Type definitions
*
*****/
typedef struct {
    U8  IsInitd;
    U8  Unit;
    U16 NumHeads;
    U16 SectorsPerTrack;
    U32 NumSectors;
    U16 BytesPerSector;
} DRIVER_INST;

/*****
*
*          Static data
*
*****/
static DRIVER_INST * _apInst[FS_TEMPLATE_NUM_UNITS];
static int          _NumUnits = 0;

/*****
*
*          Static code
*
*****/

/*****
*
*          _Init
*
*          Function description
*          Resets/Initializes the device.
*
*****/

```

```

* Parameters
*   pInst   Driver instance
*
* Return value
*   ==0     Device has been reset and initialized.
*   !=0     An error has occurred.
*/
static int _Init(DRIVER_INST * pInst) {
    FS_USE_PARA(pInst);
    return 0;
}

/*****
*
*   _Unmount
*
* Function description
*   Unmounts the volume.
*
* Parameters
*   pInst   Driver instance
*/
static void _Unmount(DRIVER_INST * pInst) {
    if (pInst->IsInitiated) {
        FS_MEMSET(pInst, 0, sizeof(DRIVER_INST));
    }
}

/*****
*
*   Public code (indirectly via callback)
*
*****/
*/

/*****
*
*   _GetDriverName
*
* Function description
*   Returns the driver name.
*
* Parameters
*   Unit    Index of the driver instance (0-based).
*
* Return value
*   Name of the driver as 0-terminated string.
*
* Additional information
*   The returned name is used by the file system to create the volume name.
*/
static const char * _GetDriverName(U8 Unit) {
    FS_USE_PARA(Unit);
    return "template";
}

/*****
*
*   _AddDevice
*
* Function description
*   Initializes a new driver instance.
*
* Return value
*   >=0     OK, index of the created driver instance.
*   < 0     An error occurred.
*/
static int _AddDevice(void) {
    U8      Unit;
    DRIVER_INST * pInst;

    if (_NumUnits >= FS_TEMPLATE_NUM_UNITS) {
        return -1;
        // Error, too many driver instances.
    }
    Unit = (U8)_NumUnits++;
}

```

```

pInst = (DRIVER_INST *)FS_AllocZeroed(sizeof(DRIVER_INST));
if (pInst == NULL) {
    return -1; // Error, out of memory.
}
_apInst[Unit] = pInst;
return Unit;
}

/*****
*
*     _Read
*
* Function description
* Reads one or more logical sectors from storage device.
*
* Parameters
* Unit           Index of the driver instance (0-based).
* SectorIndex    First sector to be read from the device.
* pData          Pointer to buffer for storing the data.
* NumSectors     Number of sectors to read.
*
* Return value
* ==0           OK, data successfully written.
* !=0           An error occurred.
*
* Additional information
* The sector data has to be stored at the following offsets in pData:
* Byte offset           Sector index
* -----
* 0                     SectorIndex
* BytesPerSector        SectorIndex + 1
* BytesPerSector * 2    SectorIndex + 2
* BytesPerSector * 3    SectorIndex + 3
* ...
* BytesPerSector * (NumSectors - 1) SectorIndex + (NumSectors - 1)
*/
static int _Read(U8 Unit, U32 SectorIndex, void * pData, U32 NumSectors) {
    DRIVER_INST * pInst;

    FS_USE_PARA(SectorIndex);
    FS_USE_PARA(pData);
    FS_USE_PARA(NumSectors);
    pInst = _apInst[Unit];
    return pInst->IsInited ? 0 : 1;
}

/*****
*
*     _Write
*
* Function description
* Writes one or more logical sectors to storage device.
*
* Parameters
* Unit           Index of the driver instance (0-based).
* SectorNo       First sector to be written to the device.
* pData          Pointer to buffer containing the data to write.
* NumSectors     Number of sectors to store.
* RepeatSame     Repeat the same data to all sectors.
*
* Return value
* ==0           OK, data successfully written.
* !=0           An error has occurred.
*
* Additional information
* The sector data is stored at the following offsets in pData
* if RepeatSame is set to 0:
* Byte offset           Sector index
* -----
* 0                     SectorIndex
* BytesPerSector        SectorIndex + 1
* BytesPerSector * 2    SectorIndex + 2
* BytesPerSector * 3    SectorIndex + 3
* ...
* BytesPerSector * (NumSectors - 1) SectorIndex + (NumSectors - 1)
*
*/

```

```

*   If RepeatSame is set to 1 then pData points to a memory region that
*   is BytePerSector bytes large. This block of data has to be stored
*   repeatedly to the sector indexes SectorIndex to SectorIndex + (NumSectors - 1)
*/
static int _Write(U8 Unit, U32 SectorIndex, const void * pData, U32 NumSectors, U8 RepeatSame) {
    DRIVER_INST * pInst;

    FS_USE_PARA(SectorIndex);
    FS_USE_PARA(pData);
    FS_USE_PARA(NumSectors);
    FS_USE_PARA(RepeatSame);
    pInst = _apInst[Unit];
    return pInst->IsInited ? 0 : 1;
}

/*****
*
*   _IoCtl
*
*   Function description
*   FS driver function. Execute device command.
*
*   Parameters
*   Unit      Index of the driver instance (0-based).
*   Cmd       Command to be executed.
*   Aux       Parameter depending on command.
*   pBuffer   Pointer to a buffer used for the command.
*
*   Return value
*   Command specific. In general a negative value means an error.
*
*   Additional information
*   A short description of the command parameters can be found in
*   the FS.h header file.
*/
static int _IoCtl(U8 Unit, I32 Cmd, I32 Aux, void * pBuffer) {
    DRIVER_INST * pInst;
    FS_DEV_INFO * pInfo;
    int          r;

    pInst = _apInst[Unit];
    r      = -1;
    FS_USE_PARA(Aux);
    switch (Cmd) {
    case FS_CMD_GET_DEVINFO:
        pInfo = (FS_DEV_INFO *)pBuffer;
        pInfo->NumHeads      = pInst->NumHeads;
        pInfo->SectorsPerTrack = pInst->SectorsPerTrack;
        pInfo->NumSectors     = pInst->NumSectors;
        pInfo->BytesPerSector = pInst->BytesPerSector;
        r = 0;
        break;
    case FS_CMD_UNMOUNT:
        //
        // (Optional)
        // Device shall be unmounted - sync all operations and mark it as unmounted
        //
        _Unmount(pInst);
        r = 0;
        break;
    case FS_CMD_UNMOUNT_FORCED:
        //
        // (Optional)
        // Device shall be unmounted
        // mark it as unmounted without syncing any pending operations
        //
        break;
    case FS_CMD_SYNC:
        //
        // (Optional)
        // Sync/flush any pending operations
        //
        break;
    case FS_CMD_FREE_SECTORS:
        //
        // (Optional)

```

```

// The range of logical sectors passed via Aux and pBuffer store invalid data.
//
r = 0;
break;
default:
break;
}
return r;
}

/*****
*
*      _InitMedium
*
* Function description
*      Initialize the specified medium.
*
* Parameters
*      Unit      Index of the driver instance (0-based).
*
* Return value
*      ==0      OK, storage medium initialized.
*      !=0      An error occurred.
*/
static int _InitMedium(U8 Unit) {
    int      r;
    DRIVER_INST * pInst;

    pInst = _apInst[Unit];
    if (pInst->IsInitiated == 0) {
        r = _Init(pInst);
        if (r) {
            FS_DEBUG_ERROROUT((FS_MTYPE_DRIVER, "DRV: Could not initialize the driver.\n"));
            return 1;
        }
        pInst->IsInitiated = 1;
    }
    return 0;
}

/*****
*
*      _GetStatus
*
* Function description
*      Returns status the presence status of the storage device.
*
* Parameters
*      Unit      Index of the driver instance (0-based).
*
* Return value
*      FS_MEDIA_STATE_UNKNOWN   The state of the media is unknown.
*      FS_MEDIA_NOT_PRESENT     No card is present.
*      FS_MEDIA_IS_PRESENT      If a card is present.
*
* Additional information
*      This function is relevant only for removable storage devices
*      such as SD cards. For other storage devices this function
*      can simply return FS_MEDIA_IS_PRESENT.
*/
static int _GetStatus(U8 Unit) {
    FS_USE_PARA(Unit);
    return FS_MEDIA_IS_PRESENT;
}

/*****
*
*      _GetNumUnits
*
* Function description
*      Returns the number of driver instances.
*
* Return value
*      >=0      OK, number of driver instances.
*      < 0      An error occurred.
*/

```



```
static int _GetNumUnits(void) {
    return _NumUnits;
}

/*****
 *
 *      Public data
 *
 *****/
*/
const FS_DEVICE_TYPE FS_TEMPLATE_Driver = {
    _GetDriverName,
    _AddDevice,
    _Read,
    _Write,
    _Ioctl,
    _InitMedium,
    _GetStatus,
    _GetNumUnits
};

/***** End of file *****/
```

Chapter 9

Configuration of emFile

This chapter describes how to configure emFile at compile time as well as at runtime.

9.1 General information

emFile was designed to be highly configurable in order to meet the different requirements of target applications. Typically, the configuration is performed by the application runtime and optionally by the user at compile time.

emFile can be used without the need for changing any of the configuration defines at compile time. All configuration defines are preconfigured with valid values, that meet the requirements of most the applications. Device and logical drivers do not have to be configured at compile time. The application can added them at runtime as required.

The default configuration of emFile can be changed at compile time by specifying different values for the configuration defines in `FS_Conf.h` that is dedicated for this purpose. This is the main configuration file for the file system. It is not recommended to modify any file system files in order to change the default values of the configuration defines.

9.2 Compile time configuration

This section describes the configuration defines of the File system and Storage layer that can be used to customize the behavior of emFile. The configuration defines of other file system components are described in their respective sections of the emFile manual.

The following types of configuration defines exist:

- Binary switches (B) - Switches can have a value of either 0 or 1, for deactivated and activated respectively. Actually, anything other than 0 works, but 1 makes it easier to read a configuration file. These switches can enable or disable a certain functionality or behavior. Switches are the simplest form of configuration defines.
- Numerical values (N) - Numerical values are used somewhere in the code in place of a numerical constant. A typical example is the configuration of the sector size of a storage device.
- Character values (C) - This is a configuration define that takes a single character as value. A typical example is the character used to separate directory name in a path to file or directory.
- Character strings (S) - A configuration define of this type can take as value a 0-terminated array of characters. A typical usage is a configuration define that specify file name.
- Text replacement (R) - This type of configuration define contains text to be replaced by the preprocessor. It is typically used for functions and variable specifiers the enable compiler specific optimizations.
- Function replacement (F) - Configuration defines of this type are function replacement macros that can also take parameters. They are typical used to substitute at compile time the default implementation of functions used by the file system.

9.2.1 General file system configuration

The following table lists the configuration defines that apply to the entire file system.

Define	Type	Default value	Description
FS_BUFFER_SIZE_FILE_COPY	N	512	Size of the work buffer used by FS_CopyFile().
FS_BUFFER_SIZE_FILE_PRINT	N	128	Size of the work buffer used by FS_FPrintf().
FS_BUFFER_SIZE_FILE_WIPE	N	512	Size of the work buffer used by FS_WipeFile().
FS_BUFFER_SIZE_TRUNCATE	N	512	Size of the work buffer used by FS_Truncate().
FS_BUFFER_SIZE_VERIFY	N	128	Size of the work buffer used by FS_Verify().
FS_DIRECTORY_DELIMITER	C	\\	Character used to delimit directories in a path.
FS_DRIVER_ALIGNMENT	N	4	Defines the minimum data alignment for 0-copy operation.
FS_FILL_PATTERN_UNUSED_DATA	N	0xFF	Value to be used to fill unused bytes in a logical sector.
FS_MAX_LEN_FULL_FILE_NAME	N	256	Maximum number of characters in a fully qualified file name.
FS_MAX_LEN_VOLUME_ALIAS	N	0	Maximum number of characters in a volume alias.
FS_MAX_PATH	N	260	Maximum number of characters in a path.

Define	Type	Default value	Description
FS_MULTI_HANDLE_SAFE	B	0	Enables or disables simultaneous read/write access to file.
FS_NUM_DIR_HANDLES	N	1	Maximum number of file system directory handles.
FS_NUM_VOLUMES	N	4	Maximum number of file system volumes.
FS_OPTIMIZATION_TYPE	N	FS_OPTIMIZATION_TYPE_BASIC	Optimization goal of the file system.
FS_OPTIMIZE	R		Function specifier for optimized functions.
FS_SUPPORT_BUSY_LED	B	1	Enables or disables support for busy LED.
FS_SUPPORT_CACHE	B	1	Enables or disables support for sector cache.
FS_SUPPORT_CHECK_MEMORY	B	0	Enables or disables the check for 0-copy operations.
FS_SUPPORT_DEINIT	B	0	Enables or disables support for deinitialization.
FS_SUPPORT_EFS	B	0	Enables or disables support for EFS file system.
FS_SUPPORT_EXT_ASCII	B	0	Enables or disables support for extended ASCII characters in file names.
FS_SUPPORT_EXT_MEM_MANAGER	B	0	Enables or disables support for external memory manager.
FS_SUPPORT_FAT	B	1	Enables or disables support for FAT file system.
FS_SUPPORT_FILE_BUFFER	B	1	Enables or disables support for file buffer.
FS_SUPPORT_FILE_NAME_ENCODING	B	0	Enables or disables support for encoded file names.
FS_SUPPORT_FREE_SECTOR	B	1	Enables or disables support for unused sector notification.
FS_SUPPORT_GPT	B	1	Enables or disables support for GUID partition tables.
FS_SUPPORT_MBCS	B	0	Enables or disables support for multi-byte character sets in file names.
FS_SUPPORT_POSIX	B	0	Enables or disables support for POSIX compatibility.
FS_SUPPORT_SECTOR_BUFFER_BURST	B	0	Enables or disables support for accessing multiple logical sectors via the internal sector buffers.
FS_SUPPORT_SECTOR_BUFFER_CACHE	B	0	Enables or disables support for caching of internal sector buffers.
FS_SUPPORT_VOLUME_ALIAS	B	1	Enables or disables support for setting an alternative volume name.

Define	Type	Default value	Description
FS_SUPPRESS_EOF_ERROR	B	0	Enables or disables end of file error reporting.
FS_VERIFY_WRITE	B	0	Enables or disables write verification.

9.2.1.1 FS_BUFFER_SIZE_FILE_COPY

FS_CopyFile() uses a work buffer located on the stack for reading the data from the file to be copied. FS_BUFFER_SIZE_FILE_COPY can be used to specify the size of this work buffer. A larger buffer provides a better performance at the expense of increased stack usage.

9.2.1.2 FS_BUFFER_SIZE_FILE_PRINT

FS_FPrintf() uses a work buffer located on the stack for formatting the data before is written to the file. FS_BUFFER_SIZE_FILE_PRINT can be used to specify the size of this work buffer. A larger buffer provides a better performance at the expense of increased stack usage.

9.2.1.3 FS_BUFFER_SIZE_FILE_WIPE

FS_WipeFile() uses a work buffer located on the stack for the random data that is written to the file. FS_BUFFER_SIZE_FILE_WIPE can be used to specify the size of this work buffer. A larger buffer provides a better performance at the expense of increased stack usage.

9.2.1.4 FS_BUFFER_SIZE_TRUNCATE

FS_Truncate() uses a work buffer located on the stack for the initialization of the extended file contents when the support for POSIX operation is enabled. FS_BUFFER_SIZE_TRUNCATE can be used to specify the size of this work buffer. A larger buffer provides a better performance at the expense of increased stack usage.

9.2.1.5 FS_BUFFER_SIZE_VERIFY

FS_Verify() uses a work buffer located on the stack for reading the data from the file to be verified. FS_BUFFER_SIZE_VERIFY can be used to specify the size of this work buffer. A larger buffer provides a better performance at the expense of increased stack usage.

9.2.1.6 FS_DIRECTORY_DELIMITER

FS_DIRECTORY_DELIMITER defines the character that is used to separate the names of the directories in a path to a file or directory. Typically the value of this define is set either to '\ ' or to '/ '.

9.2.1.7 FS_DRIVER_ALIGNMENT

The value of this define is used by the file system to check if a 0-copy operation can be executed. A 0-copy operation is performed only when the address of the data is aligned to FS_DRIVER_ALIGNMENT and the number of data bytes in the block is a multiple of the logical sector size. If the data to be read or written is not aligned to FS_DRIVER_ALIGNMENT then the file system uses the internal sector buffers for the data transfers which is typically slower in comparison with a 0-copy operation.

9.2.1.8 FS_FILL_PATTERN_UNUSED_DATA

The value of this define is used by the file system to initialize all the unused bytes of the logical sector that stores the data located at the end of a file that has a size which is not multiple of a logical sector size.

9.2.1.9 FS_MAX_LEN_FULL_FILE_NAME

This configuration define is used when `FS_MULTI_HANDLE_SAFE` is set to 1 to reserve space for the fully qualified file name in the file object assigned to an opened file. The value specified via this configuration define is also used by the BigFAT component to reserves space in the file handle for the name of the opened file.

9.2.1.10 FS_MAX_LEN_VOLUME_ALIAS

This configuration define specifies the maximum number of characters allowed in a volume alias including the 0-terminator. If set to 0 then only a reference to the volume alias is stored. A volume alias can be set via `FS_SetVolumeAlias()`. The RAM usage of the file system increases if this configuration define is set to a value different than 0. The volume alias feature can be enabled via `FS_SUPPORT_VOLUME_ALIAS`.

9.2.1.11 FS_MAX_PATH

`FS_MAX_PATH` specifies the maximum number of characters in a path to a file or directory including the 0-terminator. It is used for example by `FS_CreateDir()` for allocating a work buffer for path processing.

9.2.1.12 FS_MULTI_HANDLE_SAFE

This configuration define has to be set to 1 if the application is expected to write and read from a file at the same time. Activating this feature increases the RAM usage of the file system. For more information refer to *Resource usage* on page 1283.

9.2.1.13 FS_NUM_DIR_HANDLES

The value of this configuration define specifies the maximum of directory handles that can be opened at the same time via `FS_OpenDir()`. Please note that `FS_OpenDir()` is deprecated. It is recommended that the applications use `FS_FindFirstFile()` and `FS_FindNextFile()` instead for listing the contents of a directory.

9.2.1.14 FS_NUM_VOLUMES

`FS_NUM_VOLUMES` specifies the maximum number of volumes the file system can handle. This value is currently used only by the Journaling component and it represents the maximum number of volumes on which the journal can be enabled.

9.2.1.15 FS_OPTIMIZATION_TYPE

This configuration define can be used to modify multiple configuration defines at once in order to configure the file system operation for a specified goal such as reduced memory usage or increased speed. If `FS_OPTIMIZATION_TYPE` is set to `FS_OPTIMIZATION_TYPE_BALANCED` then the configuration defines are set as documented in the "Default value" column of the summary table that documents that define.

With `FS_OPTIMIZATION_TYPE` set to `FS_OPTIMIZATION_TYPE_MIN_SIZE` the configuration defines are set as in the following table.

Define	Value
<code>FS_SUPPORT_FREE_SECTOR</code>	0
<code>FS_SUPPORT_CACHE</code>	0
<code>FS_MAX_LEN_FULL_FILE_NAME</code>	64
<code>FS_SUPPORT_BUSY_LED</code>	0
<code>FS_SUPPORT_FILE_BUFFER</code>	0
<code>FS_SUPPORT_VOLUME_ALIAS</code>	0
<code>FS_NUM_VOLUMES</code>	1

Define	Value
FS_BUFFER_SIZE_VERIFY	32
FS_BUFFER_SIZE_FILE_COPY	32
FS_BUFFER_SIZE_FILE_WIPE	32
FS_BUFFER_SIZE_TRUNCATE	32
FS_BUFFER_SIZE_PRINT	32
FS_DEBUG_LEVEL	0
FS_JOURNAL_SUPPORT_FREE_SECTOR	0
FS_JOURNAL_SUPPORT_FAST_SECTOR_SEARCH	0
FS_FAT_SUPPORT_FAT32	0
FS_FAT_USE_FSINFO_SECTOR	0
FS_FAT_OPTIMIZE_DELETE	0
FS_FAT_OPTIMIZE_LINEAR_ACCESS	0
FS_FAT_SUPPORT_FREE_CLUSTER_CACHE	0
FS_FAT_LFN_BIT_ARRAY_SIZE	32
FS_FAT_LFN_LOWER_CASE_SHORT_NAMES	0
FS_EFS_OPTIMIZE_DELETE	0
FS_EFS_SUPPORT_STATUS_SECTOR	0
FS_EFS_SUPPORT_DIRENTRY_BUFFERS	1
FS_EFS_OPTIMIZE_LINEAR_ACCESS	0
FS_NO_CLIB	1
FS_NAND_NUM_UNITS	1
FS_NAND_SUPPORT_CLEAN	0
FS_NAND_ECC_HOOK_DEFAULT	NULL
FS_NAND_SUPPORT_BLOCK_GROUPING	0
FS_NAND_SUPPORT_FAST_WRITE	0
FS_NAND_SPI_DEVICE_LIST_DEFAULT	NULL
FS_NAND_SUPPORT_EXT_ONFI_PARA	0
FS_NAND_ONFI_DEVICE_LIST_DEFAULT	NULL
FS_NAND_2048X8_DEVICE_LIST_DEFAULT	NULL
FS_NOR_NUM_UNITS	1
FS_NOR_SUPPORT_CLEAN	0
FS_NOR_SKIP_BLANK_SECTORS	0
FS_NOR_NUM_FREE_SECTORCACHE	32
FS_NOR_SUPPORT_FORMAT	0
FS_NOR_MAX_SECTOR_BLOCKS	1
FS_NOR_DEVICE_LIST_DEFAULT	NULL
FS_NOR_OPTIMIZE_DATA_WRITE	0
FS_MMC_NUM_UNITS	1
FS_IDE_NUM_UNITS	1
FS_RAMDISK_NUM_UNITS	1
FS_WINDRIVE_NUM_UNITS	1
FS_CRYPT_NUM_UNITS	1
FS_CRYPT_AES_OPTIMIZE_MIX_SUBST	0

Define	Value
FS_LOGVOL_NUM_UNITS	1
FS_READAHEAD_NUM_UNITS	1
FS_DISKPART_NUM_UNITS	1
FS_RAID_NUM_UNITS	1
FS_SECSIZE_NUM_UNITS	1
FS_WRBUF_NUM_UNITS	1

With `FS_OPTIMIZATION_TYPE` set to `FS_OPTIMIZATION_TYPE_MAX_SPEED` the configuration defines are set as in the following table.

Define	Value
FS_SUPPORT_SECTOR_BUFFER_BURST	1
FS_SUPPORT_SECTOR_BUFFER_CACHE	1
FS_EFS_SUPPORT_FREE_CLUSTER_CACHE	1
FS_CRYPT_AES_OPTIMIZE_MIX_COLUMNS	2
FS_NOR_OPTIMIZE_EMPTY_CHECK	1

The configuration defines that are not listed in the above tables are left to their default values.

9.2.1.15.1 Optimization types

Description

Types of optimization goals.

Definition

```
#define FS_OPTIMIZATION_TYPE_BALANCED    0
#define FS_OPTIMIZATION_TYPE_MIN_SIZE   1
#define FS_OPTIMIZATION_TYPE_MAX_SPEED  2
```

Symbols

Definition	Description
<code>FS_OPTIMIZATION_TYPE_BALANCED</code>	No special optimization.
<code>FS_OPTIMIZATION_TYPE_MIN_SIZE</code>	Optimized for reduced ROM and RAM usage.
<code>FS_OPTIMIZATION_TYPE_MAX_SPEED</code>	Optimized for maximum speed.

Additional information

These values can be assigned at compile-time to the `FS_OPTIMIZATION_TYPE` configuration define.

9.2.1.16 FS_OPTIMIZE

The declaration of some of the computing intensive file system functions is prefixed with this configuration define. The application can set it to a compiler specific specifier that makes the function runs faster such as executing the function from RAM.

9.2.1.17 FS_SUPPORT_BUSY_LED

`FS_SUPPORT_BUSY_LED` can be used to enable or disable the support for a callback function that is invoked by the file system at the beginning and at the end of a sector read or write operation. As the name of this configuration define suggests the registered callback function can be used to indicate that the file system is busy accessing the storage device by turning an LED on and off. The callback function must be registered at runtime via `FS_SetBusyLEDCallback()`

9.2.1.18 FS_SUPPORT_CACHE

This configuration define can be used to enable or disable the support for sector cache. The sector cache must be enabled at runtime by the application. Refer to *Sector cache* on page 367 for more information about this.

9.2.1.19 FS_SUPPORT_CHECK_MEMORY

`FS_SUPPORT_CHECK_MEMORY` can be used to enable or disable additional checks on the data subject to 0-copy operations. The check is performed by a callback function registered by the application via `FS_SetMemAccessCallback()`. If `FS_SUPPORT_CHECK_MEMORY` is set to 1 then the callback is invoked on each read and write operation to check if a 0-copy operation can be performed.

9.2.1.20 FS_SUPPORT_DEINIT

By default the file system does not free any resources it allocates at runtime such as dynamic memory. By setting `FS_SUPPORT_DEINIT` to 1 support is enabled in the file system for freeing the allocated resources. This can be useful when the application does not longer use the file system and the resources are required for other purposes. The application can free

the resources at runtime by calling `FS_DeInit()`. If the application wishes to use the file system again it has to call `FS_Init()` before doing this in order to reallocate the resources.

9.2.1.21 FS_SUPPORT_EFS

This configuration define can be used to enable or disable the support for the EFS file system. The support for EFS file system is disabled by default.

9.2.1.22 FS_SUPPORT_EXT_ASCII

`FS_SUPPORT_EXT_ASCII` can be used to enable or disable the support for extended ASCII characters in the file names. Extended ASCII characters are characters with a value between 128 and 255. Typically, this is the range where the language-specific characters are stored. The file system requires this information for the case insensitive comparison of the file names. If the application uses file names that contain only ASCII characters that is with a value between 0 and 127 then `FS_SUPPORT_EXT_ASCII` can be set to 0 which is the default. Setting `FS_SUPPORT_EXT_ASCII` to 1 increases the ROM usage of the file system.

9.2.1.23 FS_SUPPORT_EXT_MEM_MANAGER

This configuration define can be used to enable or disable the support for external memory allocation. By default the file system uses a very simple internal memory allocator that is suitable for any embedded application. If `FS_SUPPORT_EXT_MEM_MANAGER` is set to 1 then the application can configure at runtime a pair of callback functions for the management of the memory allocation. This can be realized via `FS_SetMemHandler()`.

9.2.1.24 FS_SUPPORT_FAT

This configuration define can be used to enable or disable the support for the FAT file system. The support for FAT file system is enabled by default.

9.2.1.25 FS_SUPPORT_FILE_BUFFER

This configuration define controls the activation of the file buffer functionality. File buffers make the access to a file faster when the application is reading or writing small amounts of data. Enabling this functionality increases the ROM and RAM usage of the file system. The file buffer functionality has to be explicitly enabled at runtime. For more information refer to *File buffer* on page 388.

9.2.1.26 FS_SUPPORT_FILE_NAME_ENCODING

`FS_SUPPORT_FILE_NAME_ENCODING` can be used to enable the support for encoded file names such as UTF-8 and Shift JIS. The encoding type of the file and directory names has to be configured at runtime via `FS_FAT_SetLFNConverter()` or `FS_EFS_SetFileNameConverter()`

9.2.1.27 FS_SUPPORT_FREE_SECTOR

If `FS_SUPPORT_FREE_SECTOR` is set to 1 then the file system informs the device and logical drivers about the unused sectors. For example when a file is deleted the file system sends a notification to the driver indicating that the range or ranges of sectors that were used to store the file contents are no longer in use. The driver can use this information to optimize the management of data. Not all the drivers make use of this information. This functionality is similar to the TRIM command of the ATA command set.

9.2.1.28 FS_SUPPORT_GPT

This configuration define can be used to enable the support for GUID partition tables. With `FS_SUPPORT_GPT` set to 0 the file system is able to handle only MBR partition tables.

9.2.1.29 FS_SUPPORT_MBCS

This configuration define can be used to enable the support for file and directory names that use multi-byte character sets. Enabling this feature increases the ROM usage of the file system. The type of character set used by the file system can be configured at runtime via `FS_SetCharSetType()`.

9.2.1.30 FS_SUPPORT_POSIX

This configuration define can be used to change the behavior of the API functions so that they work in the same way as their equivalent POSIX function. The POSIX behavior is enabled by setting `FS_SUPPORT_POSIX` to 1. The behavior can also be changed at runtime using `FS_ConfigPOSIXSupport()`.

9.2.1.31 FS_SUPPORT_SECTOR_BUFFER_BURST

This configuration define can be used to enable the internal sector buffers to access more than one logical sector at once. Currently, this feature is used only for accelerating the calculation of the free space via `FS_GetVolumeInfoEx()` when the application specifies a work buffer.

9.2.1.32 FS_SUPPORT_SECTOR_BUFFER_CACHE

The `FS_SUPPORT_SECTOR_BUFFER_CACHE` configuration define can be used to activate a cache that stores information about the data present in the internal sector buffers of the file system. Enabling this feature can help accelerate file system operations that access the same logical sector such as the creation or removal of files located in the same directory.

9.2.1.33 FS_SUPPORT_VOLUME_ALIAS

This configuration define can be used to enable the setting of an alternative name for a volume name. The configured volume alias can then be used as a replacement for the volume name in a path to a file or directory or to identify a volume in a call to an API function that requires a volume name. A volume alias can be set via `FS_SetVolumeAlias()`. The configured volume alias can be obtained either via `FS_GetVolumeInfo()` or `FS_GetVolumeAlias()`.

9.2.1.34 FS_SUPPRESS_EOF_ERROR

`FS_SUPPRESS_EOF_ERROR` can be used to configure the file system to not generate an error in case of an end-of-file condition. An end-of-file condition occurs when the application is trying to read past the end of file. If `FS_SUPPRESS_EOF_ERROR` is set to 1 then no `FS_ERRORCODE_EOF` error is reported via `FS_Error()`. The handling of an end-of-file condition can be changed at runtime via `FS_ConfigEOFErrorSuppression()`.

9.2.1.35 FS_VERIFY_WRITE

`FS_VERIFY_WRITE` can be used for testing purposes to verify if the sector data was correctly written to storage. If the configuration define is set to 1 the file system reads back and compares the contents of each written logical sector to the sector data actually written. Enabling this functionality can potentially have a negative impact on the write performance of the file system. Therefore SEGGER recommends to enable it only when investigating a problem related to the file system. In addition, the write verification can be enabled and disabled at runtime via `FS_ConfigWriteVerification()`. The write verification requires a work buffer of the logical sector size that is allocated dynamically at runtime from the memory pool assigned to the file system.

9.2.2 FAT configuration

This section describes the configuration defines specific to the FAT file system.

Define	Type	Default value	Description
FS_FAT_CHECK_UNUSED_DIR_ENTRIES	B	0	Enables/disables the checking of unused directory entries.
FS_FAT_LFN_LOWER_CASE_SHORT_NAMES	B	1	Enables/disables optimization for short file names.
FS_FAT_LFN_BIT_ARRAY_SIZE	N	256	Maximum number of short file name indexes to handle at a time.
FS_FAT_LFN_MAX_SHORT_NAME	N	1000	Maximum index of a short file name.
FS_FAT_LFN_UNICODE_CONV_DEFAULT	R	&FS_UNICODE_CONV_CP437	Configures the default Unicode file name converter.
FS_FAT_OPTIMIZE_LINEAR_ACCESS	B	1	Configures the linear file access optimization.
FS_FAT_OPTIMIZE_DELETE	B	1	Enables/disables optimization for large file removal.
FS_FAT_PERMIT_RO_FILE_MOVE	B	0	Allows/denies removal of read-only file names.
FS_FAT_SUPPORT_FAT32	B	1	Enables/disables support for FAT32.
FS_FAT_SUPPORT_FREE_CLUSTER_CACHE	B	1	Enables/disables support for free cluster cache.
FS_FAT_UPDATE_DIRTY_FLAG	B	0	Enables/disables support for boot sector dirty flag.
FS_FAT_USE_FSINFO_SECTOR	B	1	Enables/disables support for FSInfo sector.
FS_MAINTAIN_FAT_COPY	B	0	Enables/disables update of the second allocation table.
FS_UNICODE_UPPERCASE_EXT	R	{0x0000, 0x0000}	Additional entries in the Unicode letter case conversion table.

9.2.2.1 FS_FAT_CHECK_UNUSED_DIR_ENTRIES

This configuration define can be used to enable additional verification steps of a directory contents. By default the disk checking operation stops the processing of a directory as soon as it reaches the first unused directory entry. If `FS_FAT_CHECK_UNUSED_DIR_ENTRIES` is set to 1 then the disk checking operation verifies that all the directory entries located after the first unused directory entry are also marked as not in used. Enabling this feature can potentially increase the time required for the disk checking operation to complete.

9.2.2.2 FS_FAT_LFN_LOWER_CASE_SHORT_NAMES

This configuration define specifies how the file system handles the creation of files or directories with names consisting only of small letters and punctuation that fit in 8.3 format. If `FS_FAT_LFN_LOWER_CASE_SHORT_NAMES` is set to 1 then the file system creates only a short directory entry for the file or directory name if it consists only of small letters and punctuation characters. This is done in order to save storage space. The information about the case of the letters in the name is preserved. If `FS_FAT_LFN_LOWER_CASE_SHORT_NAMES` is set to 0 then in addition to the short entry a long file name entry is generated. The described handling is available only when the support for long file name is enabled via `FS_FAT_SupportLFN()`.

9.2.2.3 FS_FAT_LFN_BIT_ARRAY_SIZE

`FS_FAT_LFN_BIT_ARRAY_SIZE` can be used to specify the size of the work buffer of the functionality that generates short file names from long file names. The value represents size in bits of the array used to remember the index of the short file names found. The work buffer is allocated on the stack.

9.2.2.4 FS_FAT_LFN_MAX_SHORT_NAME

The short names generated automatically by the file system for each long file name have a prefix that consists of the first characters of the long file name followed by an generated index. `FS_FAT_LFN_MAX_SHORT_NAME` can be used to specify the maximum value of that index. The maximum index value of a short file name is `FS_FAT_LFN_MAX_SHORT_NAME + FS_FAT_LFN_BIT_ARRAY_SIZE - 1`.

9.2.2.5 FS_FAT_LFN_UNICODE_CONV_DEFAULT

`FS_FAT_LFN_UNICODE_CONV_DEFAULT` specifies the set of routines to be used for the conversion of file name characters to Unicode. It can be set to `NULL` in order to save ROM space if the file names are encoded using another code page. In this case, the application must specify a Unicode converter at runtime via `FS_FAT_SetLFNConverter()`.

9.2.2.6 FS_FAT_OPTIMIZE_LINEAR_ACCESS

`FS_FAT_OPTIMIZE_LINEAR_ACCESS` can be used to enable or disable an optimization that caches the ids of clusters allocated linearly for a file. Enabling this optimization can improve read and write performance of the file system by reducing the number of accesses to the allocation table. `FS_FAT_OPTIMIZE_LINEAR_ACCESS` can take the values 0 and 1. The optimization is disabled if `FS_FAT_OPTIMIZE_LINEAR_ACCESS` is set to 0. With `FS_FAT_OPTIMIZE_LINEAR_ACCESS` set to 1, which is the default value, the file system caches only the the ids of the linearly allocated clusters that are located after the current file position.

9.2.2.7 FS_FAT_OPTIMIZE_DELETE

`FS_FAT_OPTIMIZE_DELETE` can be used to enable or disable an optimization related to the deletion of large files. If `FS_FAT_OPTIMIZE_DELETE` is set to 1 the delete operation is accelerated by updating the allocation table at once if possible. `FS_FAT_OPTIMIZE_DELETE` can be set to 0 for applications that do not deal with large files in order to reduce the ROM usage.

9.2.2.8 FS_FAT_PERMIT_RO_FILE_MOVE

By default the files and directories with the read-only file attribute set can not be moved or renamed via the API functions `FS_Move()` and `FS_Rename()` respectively. If `FS_FAT_PERMIT_RO_FILE_MOVE` is set to 1 then the read-only file attribute is ignored and the files and directories with this attribute set can be moved and renamed. This behavior can also be modified at runtime via `FS_FAT_ConfigROFileMovePermission()`

9.2.2.9 FS_FAT_SUPPORT_FAT32

`FS_FAT_SUPPORT_FAT32` can be used to enable or disable the handling of FAT32 formatted volumes. If `FS_FAT_SUPPORT_FAT32` is set to 0 then the file system will not be able to recognize volumes formatted as FAT32. In this case the file system will also not be able to format a volume as FAT32.

9.2.2.10 FS_FAT_SUPPORT_FREE_CLUSTER_CACHE

This configuration define can be used to enable or disable an optimization related to the handling of the allocation table. If `FS_FAT_SUPPORT_FREE_CLUSTER_CACHE` is set to 1 then the file system caches the information about which clusters are free in order to reduce the number of accesses to the allocation table. This functionality is used only in the FAST write mode. In the SAFE or MEDIUM write modes the functionality is not used even when

enabled at compile time. `FS_FAT_SUPPORT_FREE_CLUSTER_CACHE` can be set to 0 in order to reduce the ROM usage.

9.2.2.11 FS_FAT_UPDATE_DIRTY_FLAG

If `FS_FAT_UPDATE_DIRTY_FLAG` is set 1 then the file system sets a dirty flag in the Boot Parameter Block (BPB) of the FAT volume on the first write operation to indicate that the volume has been modified and that the file system may not have updated all the information to the storage device. The dirty flag is cleared later when `FS_Unmount()`, `FS_Unmount-Forced()`, `FS_Sync()`, or `FS_DeInit()` is called. The application can query the volume dirty flag using `FS_GetVolumeInfo()`. A dirty flag set to 1 at file system mount indicates that the file system was not properly unmounted before reset. In this case, it is recommended to call `FS_CheckDisk()` to check the integrity of the file system structure. The feature can also be enabled or disabled at runtime via `FS_FAT_ConfigDirtyFlagUpdate()`. `FS_FAT_UPDATE_DIRTY_FLAG` can be set to 0 to reduce the ROM usage.

9.2.2.12 FS_FAT_USE_FSINFO_SECTOR

`FS_FAT_USE_FSINFO_SECTOR` can be used to enable or disable the handling of the information stored to FSInfo sector of a volume formatted as FAT32. The FSInfo sector stores information about the number of free clusters and the index of the first free cluster. This information can be used to accelerate the calculation of available free space. If the information stored in the FSInfo sector is not valid then the file system falls back to calculating the free space by evaluating the entire contents of the allocation table that may take a relatively long time to complete for volumes with a large capacity. The handling of the FSInfo sector can be enabled or disabled at runtime via `FS_FAT_ConfigFSInfoSectorUse()`. `FS_FAT_USE_FSINFO_SECTOR` can be set to 0 to reduce ROM usage.

9.2.2.13 FS_MAINTAIN_FAT_COPY

This configuration define can be used to enable or disable the update of the backup allocation table of a FAT file system. If `FS_MAINTAIN_FAT_COPY` is set to 1 then the file system updates the main as well as the backup allocation table. The backup allocation table is not evaluated by the emFile but some other file systems may fail to mount a volume if the backup allocation is not present and up to date. This feature can also be enabled or disabled at runtime via `FS_FAT_ConfigFATCopyMaintenance()`. Setting `FS_MAINTAIN_FAT_COPY` to 0 increases the write performance and reduces the ROM usage.

9.2.2.14 FS_UNICODE_UPPERCASE_EXT

The long file name component of the file system uses a table allocated in ROM for the case conversion of Unicode letters. In order to save ROM space this table does not contain entries for every possible letter supported by Unicode. `FS_UNICODE_UPPERCASE_EXT` can be used to extend this table with new entries. Each entry is an initializer for a C structure containing two 16-bit values. The first value is the code point of the small letter and the second value is the code point of corresponding capital letter. The entries are separated by comma characters. The last entry must always be `{0x0000, 0x0000}` which is the end of table indicator.

9.2.3 EFS configuration

This section describes the configuration defines specific to the EFS file system.

Define	Type	Default value	Description
<code>FS_EFS_CASE_SENSITIVE</code>	B	0	Enables/disables file name case sensitivity.
<code>FS_EFS_MAX_DIR_ENTRY_SIZE</code>	N	255	Maximum directory entry size.
<code>FS_EFS_NUM_DIRENTRY_BUFFERS</code>	N	2	Maximum number of directory entry differs.

Define	Type	Default value	Description
FS_EFS_OPTIMIZE_DELETE	B	0	Enables/disables optimization for large file removal.
FS_EFS_OPTIMIZE_LINEAR_ACCESS	B	1	Configures the linear file access optimization.
FS_EFS_SUPPORT_DIRENTRY_BUFFERS	B	1	Enables/disables support for directory entry buffers.
FS_EFS_SUPPORT_FREE_CLUSTER_CACHE	B	0	Enables/disables support for free cluster cache.
FS_EFS_SUPPORT_STATUS_SECTOR	B	1	Enables/disables support for status sector.

9.2.3.1 FS_EFS_CASE_SENSITIVE

FS_EFS_CASE_SENSITIVE specifies if the comparison of file or directory names should consider the case of the letters or not. If FS_EFS_CASE_SENSITIVE is set to 0 then the case of the letters in a file or directory name is not relevant. That is TEST.TXT and test.txt represent the same file. If FS_EFS_CASE_SENSITIVE is set to 1 the TEST.TXT, test.txt and TEST.txt represent different file names. This feature can also be enabled or disabled at runtime via FS_EFS_ConfigCaseSensitivity().

9.2.3.2 FS_EFS_MAX_DIR_ENTRY_SIZE

FS_EFS_MAX_DIR_ENTRY_SIZE can be used to specify the maximum directory entry size. The minimum size of a directory entry is 21 bytes while the maximum is 255 bytes. The first 20 bytes in the directory store the size of the file, attributes, time stamps, etc. The remaining bytes are used to store the file name.

9.2.3.3 FS_EFS_NUM_DIRENTRY_BUFFERS

FS_EFS_NUM_DIRENTRY_BUFFERS specifies the number of work buffers the file system has to allocate for the handling of directory entries. The value of this configuration define is evaluated only when FS_EFS_SUPPORT_DIRENTRY_BUFFERS is set to 1.

9.2.3.4 FS_EFS_OPTIMIZE_DELETE

FS_EFS_OPTIMIZE_DELETE can be used to enable or disable an optimization related to the deletion of large files. If FS_EFS_OPTIMIZE_DELETE is set to 1 the delete operation is accelerated by updating the allocation table at once if possible. FS_EFS_OPTIMIZE_DELETE can be set to 0 for applications that do not deal with large files in order to reduce the ROM usage.

9.2.3.5 FS_EFS_OPTIMIZE_LINEAR_ACCESS

FS_EFS_OPTIMIZE_LINEAR_ACCESS can be used to enable or disable an optimization that caches the ids of clusters allocated linearly for a file. Enabling this optimization can improve read and write performance of the file system by reducing the number of accesses to the allocation table. FS_EFS_OPTIMIZE_LINEAR_ACCESS can take the values 0 and 1. The optimization is disabled if FS_EFS_OPTIMIZE_LINEAR_ACCESS is set to 0. With FS_EFS_OPTIMIZE_LINEAR_ACCESS set to 1, which is the default value, the file system caches only the ids of the linearly allocated clusters that are located after the current file position.

9.2.3.6 FS_EFS_SUPPORT_STATUS_SECTOR

This configuration define can be used to enable or disable the handling of the Status sector of an EFS formatted volume. The status sector is the equivalent of FSInfo sector for FAT32 formatted volumes. It stores information about the the number of free clusters. This information is used by the file system to accelerate the operation that calculates the available

free space. The handling of the Status sector can also be enabled or disabled at runtime via `FS_EFS_ConfigStatusSectorSupport()`.

9.2.3.7 FS_EFS_SUPPORT_DIRENTRY_BUFFERS

`FS_EFS_SUPPORT_DIRENTRY_BUFFERS` can be used to specify where the work buffers for the handling of directory entries are allocated. If `FS_EFS_SUPPORT_DIRENTRY_BUFFERS` is set to 1 the the work buffers are allocated from the memory pool of file system. Each work buffer is `FS_EFS_MAX_DIR_ENTRY_SIZE + 1` bytes large. If `FS_EFS_SUPPORT_DIRENTRY_BUFFERS` is set to 0 then the work buffers are allocated on the stack which is the default.

9.2.3.8 FS_EFS_SUPPORT_FREE_CLUSTER_CACHE

This configuration define can be used to enable or disable an optimization related to the handling of the allocation table. If `FS_EFS_SUPPORT_FREE_CLUSTER_CACHE` is set to 1 then the file system caches the information about which clusters are free in order to reduce the number of accesses to the allocation table. This functionality is used only in the FAST write mode. In the SAFE or MEDIUM write modes the functionality is not used even when enabled at compile time. `FS_EFS_SUPPORT_FREE_CLUSTER_CACHE` can be set to 0 in order to reduce the ROM usage.

9.2.4 Storage layer configuration

This section describes the configuration defines specific to the Storage layer.

Define	Type	Default value	Description
<code>FS_STORAGE_ENABLE_STAT_COUNTERS</code>	B	0	Enables/disables support for statistical counters.
<code>FS_STORAGE_SUPPORT_DEVICE_ACTIVITY</code>	B	0	Enables/disables the support for device activity callback.
<code>FS_STORAGE_SUPPORT_MOUNT</code>	B	0	Enables/disables the support for mounting the storage device.

9.2.4.1 FS_STORAGE_ENABLE_STAT_COUNTERS

This configuration define can be used to enable the statistical counters of the Storage layer. The statistical counters are enabled by default when the file system is configured at compile time with `FS_DEBUG_LEVEL` set to a value greater than or equal to `FS_DEBUG_LEVEL_CHECK_PARA`. The statistical counters can be queried using `FS_STORAGE_GetCounters()` and cleared using `FS_STORAGE_ResetCounters()`

9.2.4.2 FS_STORAGE_SUPPORT_DEVICE_ACTIVITY

`FS_STORAGE_SUPPORT_DEVICE_ACTIVITY` enables or disables the support for a callback that is invoked by the file system at each sector read or write operation. The callback function can be registered by the application at runtime via `FS_STORAGE_SetOnDeviceActivityCallback()`. The support for the device activity callback is enabled by default at compile time when the file system is configured with `FS_DEBUG_LEVEL` set to a value greater than or equal to `FS_DEBUG_LEVEL_CHECK_PARA`.

9.2.4.3 FS_STORAGE_SUPPORT_MOUNT

This configuration define enables or disables the support for the mount operation. The mount operation enables the application to control how the storage device is accessed such as in read-only or read and write mode. With the support for the mount operation disabled, the storage device is always mounted automatically in read and write mode at the first access to it. Setting `FS_STORAGE_SUPPORT_MOUNT` to one enables the following API functions: `FS_STORAGE_Mount()`, `FS_STORAGE_MountEx()`, `FS_STORAGE_SetAutoMountType()`, `FS_STORAGE_SetAutoMountTypeEx()`, `FS_STORAGE_GetAutoMountType()`, `FS_STORAGE_GetAu-`

toMountTypeEx(), FS_STORAGE_GetMountType(), FS_STORAGE_GetMountTypeEx(). In addition, the RAM usage of the file system increases by two bytes per volume instance.

9.2.5 Standard C function replacement

This section describes the configuration defines that can be used to replace the standard C functions called by emFile by other functions.

Define	Type	Default value	Description
FS_MEMCMP(s1, s2, n)	F	memcmp(s1, s2, n)	Replaces memcmp() standard C function.
FS_MEMCPY(s1, s2, n)	F	memcpy(s1, s2, n)	Replaces memcpy() standard C function.
FS_MEMSET(s, c, n)	F	memset(s, c, n)	Replaces memset() standard C function.
FS_MEMXOR(pd, ps, n)	F	SEGGER_memxor(pd, ps, n)	Performs XOR operation on a memory range.
FS_NO_CLIB	B	0	Enables/disables standard C function replacements.
FS_STRCHR(s, c)	F	strchr(s, c)	Replaces strchr() standard C function.
FS_STRCMP(s1, s2)	F	strcmp(s1, s2)	Replaces strcmp() standard C function.
FS_STRCPY(s1, s2)	F	strcpy(s1, s2)	Replaces strcpy() standard C function.
FS_STRLEN(s)	F	strlen(s)	Replaces strlen() standard C function.
FS_STRNCAT(s1, s2, n)	F	strncat(s1, s2, n)	Replaces strncat() standard C function.
FS_STRNCMP(s1, s2, n)	F	strncmp(s1, s2, n)	Replaces strncmp() standard C function.
FS_STRNCPY(s1, s2, n)	F	strncpy(s1, s2, n)	Replaces strncpy() standard C function.
FS_TOLOWER(c)	F	tolower(c)	Replaces tolower() standard C function.
FS_Toupper(c)	F	toupper(c)	Replaces toupper() standard C function.
FS_ISLOWER(c)	F	islower(c)	Replaces islower() standard C function.
FS_ISUPPER(c)	F	isupper(c)	Replaces isupper() standard C function.
FS_VSNPRINTF(s, n, f, a)	F	SEGGER_vsnprintf(s, n, f, a)	Replaces vsnprintf() standard C function.

9.2.5.1 FS_NO_CLIB

emFile uses functions of the standard C library to preform specific operations. If FS_NO_CLIB is set to 1 then the file system calls internal functions instead to perform these operations instead of the equivalent standard C library functions.

9.2.6 Sample configuration

A sample configuration file `FS_Conf.h` can be found in the `Config` folder of the `emFile` shipment. If you want to change the default configuration, insert the corresponding configuration defines in this file.

```
/******  
*                (c) SEGGER Microcontroller GmbH                *  
*                The Embedded Experts                            *  
*                www.segger.com                                  *  
*****  
  
----- END-OF-HEADER -----  
  
File      : FS_Conf.h  
Purpose   : emFile compile time configuration.  
*/  
#ifndef FS_CONF_H  
#define FS_CONF_H          // Avoid multiple inclusion  
  
//  
// Enable the EFS file system.  
//  
#define FS_SUPPORT_FAT      0  
#define FS_SUPPORT_EFS     1  
  
#endif          // Avoid multiple inclusion  
  
/***** End of file *****/
```

9.3 Runtime configuration

The runtime configuration of the file system is realized via a set of functions that have to be implemented by the application according to its requirements. This section describes these functions in detail.

emFile comes with sample implementations that can be used as a starting point for creating a custom file system configuration. Every folder of the emFile shipment that contain sample hardware layer implementations also contain a suitable configuration file (e.g. `Sample/FS/RAM/FS_ConfigRamDisk.c`) with implementations of runtime configuration functions explained in this chapter. The configuration files can be used without modification, to run emFile "out of the box".

The following table lists the names of the functions that have to be provided by the application followed by a detailed description of these functions. Additional functions are required to be implemented by the application if the emFile is configured to generate debug messages. For additional information refer to *Debug messages* on page 1257

Function	Description
<code>FS_X_AddDevices()</code>	Configures the file system.
<code>FS_X_GetTimeDate()</code>	Returns the current time and date.

9.3.1 FS_X_AddDevices()

Description

Configures the file system.

Prototype

```
void FS_X_AddDevices(void);
```

Additional information

This function is responsible for configuring the file system at runtime and it has to be implemented by any application that uses emFile.

`FS_X_AddDevices()` is called during the file system initialization from either `FS_Init()` or `FS_STORAGE_Init()`. At the minimum, this function has to provide memory for the file system to work with either via `FS_AssignMemory()` or `FS_SetMemHandler()`. In addition, `FS_X_AddDevices()` has to add at least one device driver to the file system via `FS_AddDevice()` and to configure the device driver.

API functions that access a storage device may not be called in `FS_X_AddDevices()` because the device drivers may not be ready at this point to perform any data transfers.

9.3.2 FS_X_GetTimeDate()

Description

Returns the current time and date.

Prototype

```
U32 FS_X_GetTimeDate(void);
```

Return value

Current time and date in a format suitable for the file system.

Additional information

This function is called by the file system in order to generate the time stamps for the accessed files and directories. `FS_X_GetTimeDate()` is not required when the application accesses the storage device only via the Storage layer and not via the File system layer.

Alternatively, the application can register a runtime a callback function via `FS_SetTimeDateCallback()` that returns the date and time.

The return value is formatted as follows:

Bit range	Description
0-4	2-second count (0-29)
5-10	Minutes (0-59)
11-15	Hours (0-23)
16-20	Day of month (1-31)
21-24	Month of year (1-12)
25-31	Count of years from 1980 (0-127)

Chapter 10

OS integration

This chapter provides information about how to configure emFile to work in a multitasking application.

10.1 General information

emFile does not require an operating system to work. However, when an application uses two or more tasks to concurrently access the file system then these accesses have to be synchronized in order to prevent a corruption of the file system structure. The access to the file system is synchronized via a set of API functions called OS layer. The implementation of the OS layer is specific to the OS used by the application. emFile comes with ready to use OS layers for SEGGER embOS and Micrium uC/OS. The implementation of these OS layers can be found in the `Sample/FS/OS` folder of the emFile shipment. Support for other operating systems is available on request.

10.2 Compile time configuration

By default, the support for OS is disabled in emFile because the majority of the applications either use only one task or if they use multiple tasks only one task accesses the file system at a time. Therefore, the OS support has to be explicitly enabled at compile time. The following table lists the configuration defines that can be used for this.

Macro	Default	Type	Description
FS_OS_LOCKING	FS_OS_LOCKING_NONE	N	Configures the OS support

10.2.1 FS_OS_LOCKING

Setting `FS_OS_LOCKING` to `FS_OS_LOCKING_NONE` disables the OS support. This is the default value. The OS layer is not required in this case. If `FS_OS_LOCKING` is set to `FS_OS_LOCKING_API` or `FS_OS_LOCKING_DRIVER` then the support for OS is enabled and an OS layer is required.

With `FS_OS_LOCKING` set to `FS_OS_LOCKING_API` (coarse lock granularity) the file system requires only one OS synchronization object. The task synchronization takes place in API layer. The file system is locked at the beginning of an API function and unlocked upon return. This means that only one task can execute a file system operation at a time. The API functions of the device and logical driver do not lock the file system. These are the functions that are described in the *Device drivers* on page 389 and *Logical drivers* on page 1148 sections. It is the responsibility of the application to lock the file system by using either `FS_Lock()/FS_Unlock()` or `FS_LockVolume()/FS_UnlockVolume()` when calling one of the driver API functions.

With `FS_OS_LOCKING` set to `FS_OS_LOCKING_DRIVER` (fine lock granularity) an OS synchronization object is required for each device or logical driver type configured by the application. In addition an OS synchronization object is required for the protection of the internal file system resources that are shared between the tasks. In this locking mode the task synchronization takes place at driver level and every time a task accesses an internal shared resource such as sector buffer or file handle. It is recommended to use this type of locking only when the file system is configured to use different storage device types such as NOR and NAND flash, SD card and NAND flash etc. This type of locking cannot be used when the same storage device is accessed via two different logical drivers. For example when a NAND flash device is partitioned in two and the first partition is accessed via the *Encryption driver* on page 1154 and the second via the *RAID1 driver* on page 1172

10.2.1.1 OS locking

Description

Types of locking for multitasking access.

Definition

```
#define FS_OS_LOCKING_NONE      0
#define FS_OS_LOCKING_API      1
#define FS_OS_LOCKING_DRIVER   2
```

Symbols

Definition	Description
FS_OS_LOCKING_NONE	No locking against concurrent access.
FS_OS_LOCKING_API	Locking is performed at API function level (coarse locking).
FS_OS_LOCKING_DRIVER	Locking is performed at device driver level (fine locking).

Additional information

These values can be assigned at compile-time to the `FS_OS_LOCKING` configuration define.

10.3 Runtime configuration

emFile requires an OS layer specific to the OS used by the application if `FS_OS_LOCKING` is set to a value different than 0 at compile time. The OS layer is responsible for providing the OS specific synchronization routines the file system can use to make sure that only one task executes a critical section of the file system.

The following table lists the functions of the OS layer followed by a detailed description of each function.

Function	Description
<code>FS_X_OS_Init()</code>	Allocates the OS layer resources.
<code>FS_X_OS_DeInit()</code>	Releases the OS layer resources.
<code>FS_X_OS_Delay()</code>	Blocks the execution for the specified time.
<code>FS_X_OS_Lock()</code>	Acquires the specified OS synchronization object.
<code>FS_X_OS_Unlock()</code>	Releases the specified OS synchronization object.
<code>FS_X_OS_Wait()</code>	Waits for an OS synchronization object to be signaled.
<code>FS_X_OS_Signal()</code>	Signals an OS synchronization object.
<code>FS_X_OS_GetTime()</code>	Number of milliseconds elapsed since the start of the application.

10.3.1 FS_X_OS_Init()

Description

Allocates the OS layer resources.

Prototype

```
void FS_X_OS_Init(unsigned NumLocks);
```

Parameters

Parameter	Description
NumLocks	Number of OS synchronization objects required.

Additional information

This function has to be implemented by any OS layer. `FS_X_OS_Init()` is called during the file system initialization. It has to create the number of specified OS synchronization objects. The type of the OS synchronization object is not relevant as long as it can be used to protect a critical section. The file system calls `FS_X_OS_Lock()` before it enters a critical section and `FS_X_OS_Unlock()` when the critical sector is leaved.

In addition, `FS_X_OS_Init()` has to create the OS synchronization object used by the optional functions `FS_X_OS_Signal()` and `FS_X_OS_Wait()`.

10.3.2 FS_X_OS_DeInit()

Description

Releases the OS layer resources.

Prototype

```
void FS_X_OS_DeInit(void);
```

Additional information

This function has to be implemented only for file system configurations that set `FS_SUPPORT_DEINIT` to 1. `FS_X_OS_DeInit()` has to release all the OS synchronization objects that were allocated in `FS_X_OS_Init()`.

10.3.3 FS_X_OS_Delay()

Description

Blocks the execution for the specified time.

Prototype

```
void FS_X_OS_Delay(int ms);
```

Parameters

Parameter	Description
ms	Number of milliseconds to block the execution.

Additional information

The implementation of this function is optional. `FS_X_OS_Delay()` is called by implementations of the hardware layers to block efficiently the execution of a task.

10.3.4 FS_X_OS_Lock()

Description

Acquires the specified OS synchronization object.

Prototype

```
void FS_X_OS_Lock(unsigned LockIndex);
```

Parameters

Parameter	Description
LockIndex	Index of the OS synchronization object (0-based).

Additional information

This function has to be implemented by any OS layer. The file system calls `FS_X_OS_Lock()` when it tries to enter a critical section that is protected by the OS synchronization object specified via [LockIndex](#). `FS_X_OS_Lock()` has to block the execution of the calling task until the OS synchronization object can be acquired. The OS synchronization object is later released via a call to `FS_X_OS_Unlock()`. All OS synchronization objects are created in `FS_X_OS_Init()`.

It is guaranteed that the file system does not perform a recursive locking of the OS synchronization object. That is `FS_X_OS_Lock()` is not called two times in a row from the same task on the same OS synchronization object without a call to `FS_X_OS_Unlock()` in between.

10.3.5 FS_X_OS_Unlock()

Description

Releases the specified OS synchronization object.

Prototype

```
void FS_X_OS_Unlock(unsigned LockIndex);
```

Parameters

Parameter	Description
<code>LockIndex</code>	Index of the OS synchronization object (0-based).

Additional information

This function has to be implemented by any OS layer. The OS synchronization object to be released was acquired via a call to `FS_X_OS_Lock()`. All OS synchronization objects are created in `FS_X_OS_Init()`.

10.3.6 FS_X_OS_Wait()

Description

Waits for an OS synchronization object to be signaled.

Prototype

```
int FS_X_OS_Wait(int TimeOut);
```

Parameters

Parameter	Description
<code>TimeOut</code>	Maximum time in milliseconds to wait for the OS synchronization object to be signaled.

Return value

= 0 OK, the OS synchronization object was signaled within the timeout.
≠ 0 An error or a timeout occurred.

Additional information

The implementation of this function is optional. `FS_X_OS_Wait()` is called by some hardware layer implementations that work in event-driven mode. That is a condition is not checked periodically by the CPU until it is met but the hardware layer calls `FS_X_OS_Wait()` to block the execution while waiting for the condition to be met. The blocking is realized via an OS synchronization object that is signaled via `FS_X_OS_Signal()` in an interrupt that is triggered when the condition is met.

10.3.7 FS_X_OS_Signal()

Description

Signals an OS synchronization object.

Prototype

```
void FS_X_OS_Signal(void);
```

Additional information

The implementation of this function is optional. `FS_X_OS_Signal()` is called by some hardware layer implementations that work in event-driven mode. Refer to `FS_X_OS_Wait()` for more details about how this works.

10.3.8 FS_X_OS_GetTime()

Description

Number of milliseconds elapsed since the start of the application.

Prototype

```
U32 FS_X_OS_GetTime(void);
```

Return value

Number of milliseconds elapsed.

Additional information

The implementation of this function is optional. `FS_X_OS_GetTime()` is not called by the file system. It is typically used by some test applications as time base for performance measurements.

10.3.9 Sample implementation

The following example shows the implementation of an OS layer for SEGGER embOS. The implementation file is located in the `Sample/FS/OS` folder of the emFile shipment.

```

/*****
 *
 *          (c) SEGGER Microcontroller GmbH
 *          The Embedded Experts
 *          www.segger.com
 *
 *****/

----- END-OF-HEADER -----

File   : FS_OS_embOS.c
Purpose: embOS OS Layer for the file system.
*/

/*****
 *
 *      #include Section
 *
 *****/
#include "FS.h"
#include "FS_OS.h"
#include "RTOS.h"

/*****
 *
 *      Static data
 *
 *****/
static OS_RSEMA  * _paSema;
static OS_EVENT  _Event;
#if FS_SUPPORT_DEINIT
static unsigned  _NumLocks;
#endif

/*****
 *
 *      Public code
 *
 *****/

/*****
 *
 *      FS_X_OS_Lock
 *
 *      Function description
 *      Acquires the specified OS resource.
 *
 *      Parameters
 *      LockIndex   Identifies the OS resource (0-based).
 *
 *      Additional information
 *      This function has to block until it can acquire the OS resource.
 *      The OS resource is later released via a call to FS_X_OS_Unlock().
 */
void FS_X_OS_Lock(unsigned LockIndex) {
    OS_RSEMA * pSema;

    pSema = _paSema + LockIndex;
    (void)OS_Use(pSema);
    FS_DEBUG_LOG((FS_MTYPE_OS, "OS: LOCK Index: %d\n", LockIndex));
}

/*****
 *
 *      FS_X_OS_Unlock
 *
 *      Function description
 *      Releases the specified OS resource.
 *
 *****/

```

```

* Parameters
*   LockIndex   Identifies the OS resource (0-based).
*
* Additional information
*   The OS resource to be released was acquired via a call to FS_X_OS_Lock()
*/
void FS_X_OS_Unlock(unsigned LockIndex) {
    OS_RSEMA * pSema;

    pSema = _paSema + LockIndex;
    FS_DEBUG_LOG((FS_MTYPE_OS, "OS: UNLOCK Index: %d\n", LockIndex));
    OS_Unuse(pSema);
}

/*****
*
*   FS_X_OS_Init
*
* Function description
*   Initializes the OS resources.
*
* Parameters
*   NumLocks   Number of locks that should be created.
*
* Additional information
*   This function is called by FS_Init(). It has to create all resources
*   required by the OS to support multi tasking of the file system.
*/
void FS_X_OS_Init(unsigned NumLocks) {
    unsigned i;
    OS_RSEMA * pSema;
    unsigned NumBytes;

    NumBytes = NumLocks * sizeof(OS_RSEMA);
    _paSema = SEGGER_PTR2PTR(OS_RSEMA, FS_ALLOC_ZEROED((I32)NumBytes, "OS_RSEMA"));
    pSema = _paSema;
    for (i = 0; i < NumLocks; i++) {
        OS_CREATERSEMA(pSema++);
    }
    OS_EVENT_Create(&_Event);
#ifdef FS_SUPPORT_DEINIT
    _NumLocks = NumLocks;
#endif
}

#ifdef FS_SUPPORT_DEINIT

/*****
*
*   FS_X_OS_DeInit
*
* Function description
*   This function has to release all the resources that have been
*   allocated by FS_X_OS_Init().
*/
void FS_X_OS_DeInit(void) {
    unsigned i;
    OS_RSEMA * pSema;
    unsigned NumLocks;

    NumLocks = _NumLocks;
    pSema = &_paSema[0];
    for (i = 0; i < NumLocks; i++) {
        OS_DeleteRSEma(pSema);
        pSema++;
    }
    OS_EVENT_Delete(&_Event);
    FS_Free(_paSema);
    _paSema = NULL;
    _NumLocks = 0;
}

#endif // FS_SUPPORT_DEINIT

/*****
*

```

```

*      FS_X_OS_GetTime
*/
U32 FS_X_OS_GetTime(void) {
    return (U32)OS_GetTime32();
}

/*****
*
*      FS_X_OS_Wait
*
*      Function description
*      Waits for an event to be signaled.
*
*      Parameters
*      Timeout  Time to be wait for the event object.
*
*      Return value
*      ==0      Event object was signaled within the timeout value
*      !=0      An error or a timeout occurred.
*/
int FS_X_OS_Wait(int TimeOut) {
    int r;

    r = -1;
    if ((U8)OS_EVENT_WaitTimed(&_Event, TimeOut) == 0u) {
        r = 0;
    }
    return r;
}

/*****
*
*      FS_X_OS_Signal
*
*      Function description
*      Signals an event.
*/
void FS_X_OS_Signal(void) {
    OS_EVENT_Set(&_Event);
}

/*****
*
*      FS_X_OS_Delay
*
*      Function description
*      Blocks the execution for the specified number of milliseconds.
*/
void FS_X_OS_Delay(int ms) {
    OS_Delay(ms + 1);
}

/***** End of file *****/

```

Chapter 11

Debugging

This chapter provides information about how to troubleshoot emFile in case that is not working as expected.

11.1 General information

emFile comes with an optional debug functionality that helps investigating potential issues related to the file system operation. The debug functionality can be used by an application to enable additional parameter and consistency checks and to enable the reporting of debug messages. The type of checks to be performed as well as the type of debug messages to be generated can be configured at compile time by assigning a different value (debug level) to `FS_DEBUG_LEVEL` on page 1262 configuration define.

Note

Enabling the debug functionality can have a negative effect on the read and write performance and it can also increase the ROM and RAM usage of the file system.

11.2 Debug messages

Debug messages are human-readable text messages generated by the file system on error or warning conditions or when specific internal operations are performed. The file system provides the debug messages as 0-terminated strings to the application via calls to dedicated API functions. These functions have to be implemented in the application and the application is free to choose how to handle the debug messages. For example the debug messages can be forwarded to a host system via the SEGGER Real Time Transfer (<https://www.segger.com/products/debug-probes/j-link/technology/about-real-time-transfer/>)

The debug messages are organized in three classes: error, warning and trace. Each debug message class is passed to the application via a separate API function. In addition, the reporting of a specific class of debug messages can be enabled or disabled via different debug levels. The table below lists the supported debug message classes together with the API function that is used to pass them to the application.

Class	Handling function	Debug level	Description
error	<code>FS_X_ErrorOut()</code>	\geq <code>FS_DEBUG_LEVEL_LOG_ERRORS</code>	Fault condition the file system cannot recover from.
warning	<code>FS_X_Warn()</code>	\geq <code>FS_DEBUG_LEVEL_LOG_WARNINGS</code>	Fault condition the file system can recover from.
trace	<code>FS_X_Log()</code>	\geq <code>FS_DEBUG_LEVEL_LOG_ALL</code>	Information about internal processing.

The debug messages also have a type assigned to them that is used to identify the component of the file system that reported that message. Refer to section *Debug message types* on page 1274 for a description of the supported message types. It is possible to configure at compile time as well as at runtime what type of debug messages are reported by the file system. The sections *FS_LOG_MASK_DEFAULT* on page 1263 and *Runtime configuration* on page 395 provide more information about how this is realized.

11.2.1 Debug output and error functions

This section describes the API functions an application has to provide in order to be able to handle the debug messages and assertion errors generated by the file system. emFile comes with a sample implementation for these functions that demonstrate how to send the debug messages to a host system. The implementation of the sample functions can be found in the `Config/FS_ConfigIO.c` file of the emFile shipment. These functions can be adapted according to the requirements of the target application. The typical release build does not use debugging and therefore these functions may be removed from the source code to save some ROM space if the linker is not able to eliminate unreferenced functions automatically.

The table below and the next sections provide more detailed information about these API functions.

Function	Description
<code>FS_X_ErrorOut()</code>	API function called to report an error debug message.
<code>FS_X_Log()</code>	API function called when a trace debug message is generated.
<code>FS_X_Panic()</code>	Handles an assertion error.
<code>FS_X_Warn()</code>	API function called to report a warning debug message.

11.2.2 FS_X_ErrorOut()

Description

API function called to report an error debug message.

Prototype

```
void FS_X_ErrorOut(const char * s);
```

Parameters

Parameter	Description
s	Reported text debug message (0-terminated). It can never be NULL.

Additional information

This function is optional. It is required to be present only when the file system is built with `FS_DEBUG_LEVEL` set to a value greater than or equal to `FS_DEBUG_LEVEL_LOG_ERRORS`. The generated text message is not terminated by a newline character.

Example

```
#include <stdio.h>

void FS_X_ErrorOut(const char * s) {
    printf("FS error: %s\n", s);
}
```

11.2.3 FS_X_Log()

Description

API function called when a trace debug message is generated.

Prototype

```
void FS_X_Log(const char * s);
```

Parameters

Parameter	Description
s	Generated text debug message (0-terminated). It can never be NULL.

Additional information

This function is optional. It is required to be present only when the file system is built with `FS_DEBUG_LEVEL` set to a value greater than or equal to `FS_DEBUG_LEVEL_LOG_ALL`. The generated text message terminated by a newline character as required.

Example

```
#include <stdio.h>

void FS_X_Log(const char * s) {
    puts(s);
}
```

11.2.4 FS_X_Panic()

Description

Handles an assertion error.

Prototype

```
void FS_X_Panic(int ErrorCode);
```

Parameters

Parameter	Description
ErrorCode	Identifies the type of error.

Additional information

This function is called by the file system only when the sources are built with `FS_DEBUG_LEVEL` set to a value greater than or equal to `FS_DEBUG_LEVEL_CHECK_PARA`. `FS_X_Panic()` is called only on a critical error condition such as insufficient memory or invalid parameter.

Refer to *Error codes* on page 335 for permitted values for `ErrorCode`.

Example

```
#include <stdio.h>

void FS_X_Panic(int ErrorCode) {
    printf("FS panic: %d\n", ErrorCode);
    while (1) {
        ;
    }
}
```

11.2.5 FS_X_Warn()

Description

API function called to report a warning debug message.

Prototype

```
void FS_X_Warn(const char * s);
```

Parameters

Parameter	Description
s	Reported text debug message (0-terminated). It can never be NULL.

Additional information

This function is optional. It is required to be present only when the file system is built with `FS_DEBUG_LEVEL` set to a value greater than or equal to `FS_DEBUG_LEVEL_LOG_WARNINGS`. The generated text message is not terminated by a newline character.

Example

```
#include <stdio.h>

void FS_X_Warn(const char * s) {
    printf("FS warning: %s\n", s);
}
```

11.3 Configuration

The debug functionality has to be configured at compiled time and can be optionally configured at runtime.

11.3.1 Compile time configuration

The compile time configuration is realized via preprocessor defines that have to be added to the `FS_Conf.h` file which is the main configuration file of emFile. For detailed information about the configuration of emFile and of the configuration define types, refer to *Configuration of emFile* on page 1218. The following table lists the configuration defines supported by the debug functionality.

Define	Type	Default value	Description
<code>FS_DEBUG_LEVEL</code>	N	<code>FS_DEBUG_LEVEL_CHECK_PARA</code>	Default behavior of the debug functionality.
<code>FS_DEBUG_MAX_LEN_MESSAGE</code>	N	100	Size of the format buffer in bytes.
<code>FS_DEBUG_STATIC_MESSAGE_BUFFER</code>	B	0	Configures where the buffer for the formatting of debug messages is allocated.
<code>FS_LOG_MASK_DEFAULT</code>	N	<code>FS_MTYPE_INIT</code>	Default debug message types to be traced.
<code>FS_X_PANIC()</code>	F	<code>FS_X_Panic()</code>	Handles an assertion error.

11.3.1.1 FS_DEBUG_LEVEL

This define can be used to configure the behavior of the debug functionality. The application can choose between six debug levels that enable different features of the debug functionality. The debug levels are structured hierarchically so that higher debug levels also enable the features assigned to lower debug levels.

11.3.1.1.1 Debug levels

Description

Amount of debug information.

Definition

```
#define FS_DEBUG_LEVEL_NOCHECK      0
#define FS_DEBUG_LEVEL_CHECK_PARA  1
#define FS_DEBUG_LEVEL_CHECK_ALL   2
#define FS_DEBUG_LEVEL_LOG_ERRORS  3
#define FS_DEBUG_LEVEL_LOG_WARNINGS 4
#define FS_DEBUG_LEVEL_LOG_ALL     5
```

Symbols

Definition	Description
FS_DEBUG_LEV-EL_NOCHECK	No run time checks are performed.
FS_DEBUG_LEV-EL_CHECK_PARA	Parameter checks are performed.
FS_DEBUG_LEV-EL_CHECK_ALL	Parameter checks and consistency checks are performed.
FS_DEBUG_LEV-EL_LOG_ERRORS	Error conditions are reported.
FS_DEBUG_LEV-EL_LOG_WARNINGS	Error and warning conditions are reported.
FS_DEBUG_LEV-EL_LOG_ALL	Error and warning conditions as well as trace messages are reported.

Additional information

These values can be assigned at compile-time to the `FS_DEBUG_LEVEL` configuration define.

The debug levels are hierarchical so that higher debug levels also enable the features assigned to lower debug levels.

11.3.1.2 FS_DEBUG_MAX_LEN_MESSAGE

This define specifies the size of the buffer to be used for the formatting of debug messages. This buffer is allocated on the stack. It can be set to a smaller value than the default to save stack space. The debug messages will be truncated if they do not fit in the formatting buffer.

11.3.1.3 FS_DEBUG_STATIC_MESSAGE_BUFFER

`FS_DEBUG_STATIC_MESSAGE_BUFFER` can be used to specify where the buffer used for the formatting of debug messages is allocated (statically or on the stack). By default the buffer for the formatting of debug messages are allocate on the stack. The size of the buffer is specified by `FS_DEBUG_MAX_LEN_MESSAGE`. The stack load can be reduced by setting `FS_DEBUG_STATIC_MESSAGE_BUFFER` to 1 in which case the buffer is allocated statically. It is not recommended to set `FS_DEBUG_STATIC_MESSAGE_BUFFER` to 1 with `FS_OS_LOCKING` set to `FS_OS_LOCKING_DRIVER` because the debug messages may get corrupted when two or more tasks access different storage devices of different types at the same time.

11.3.1.4 FS_LOG_MASK_DEFAULT

This configuration define specifies the type of debug messages to be generated from the class of log messages. The value is a bitwise-OR combination of the message types described in the section *Debug message types* on page 1274. The type of log debug messages

to be generated can be modified at runtime via `FS_SetLogFilter()` and `FS_AddLogFilter()`.

11.3.1.5 FS_X_PANIC()

This configuration define can be used to replace the default handler for assertion errors. It takes the error code as parameter. Refer to `FS_X_Panic()` for more information.

11.3.2 Runtime configuration

The type of debug messages that are generated by the file system during the operation can be managed using the API functions listed in the following table.

Function	Description
<code>FS_AddErrorFilter()</code>	Enables error debug messages.
<code>FS_AddLogFilter()</code>	Enables trace debug messages.
<code>FS_AddWarnFilter()</code>	Enables warning debug messages.
<code>FS_GetErrorFilter()</code>	Queries activation status of error debug messages.
<code>FS_GetLogFilter()</code>	Queries activation status of trace debug messages.
<code>FS_GetWarnFilter()</code>	Queries activation status of warning debug messages.
<code>FS_SetErrorFilter()</code>	Enables and disables error debug messages.
<code>FS_SetLogFilter()</code>	Enables and disables trace debug messages.
<code>FS_SetWarnFilter()</code>	Enables and disables warning debug messages.

11.3.2.1 FS_AddErrorFilter()

Description

Enables error debug messages.

Prototype

```
void FS_AddErrorFilter(U32 FilterMask);
```

Parameters

Parameter	Description
<code>FilterMask</code>	Specifies the message types to be enabled.

Additional information

`FS_AddErrorFilter()` can be used to enable a specified set of debug message types of the error class.

This function is optional and is available only when the file system is built with `FS_DEBUG_LEVEL` set to a value equal or greater than `FS_DEBUG_LEVEL_LOG_ERRORS`.

`FileMask` is specified by or-ing one or more message types described at *Debug message types* on page 1274.

11.3.2.2 FS_AddLogFilter()

Description

Enables trace debug messages.

Prototype

```
void FS_AddLogFilter(U32 FilterMask);
```

Parameters

Parameter	Description
<code>FilterMask</code>	Specifies the message types to be enabled.

Additional information

`FS_AddLogFilter()` can be used to enable a specified set of debug message types of the trace class.

This function is optional and is available only when the file system is built with `FS_DEBUG_LEVEL` set to a value equal or greater than `FS_DEBUG_LEVEL_LOG_ALL`.

`FileMask` is specified by or-ing one or more message types described at *Debug message types* on page 1274.

11.3.2.3 FS_AddWarnFilter()

Description

Enables warning debug messages.

Prototype

```
void FS_AddWarnFilter(U32 FilterMask);
```

Parameters

Parameter	Description
<code>FilterMask</code>	Specifies the message types to be enabled.

Additional information

`FS_AddWarnFilter()` can be used to enable a specified set of debug message types of the warning class.

This function is optional and is available only when the file system is built with `FS_DEBUG_LEVEL` set to a value equal or greater than `FS_DEBUG_LEVEL_LOG_WARNINGS`.

`FileMask` is specified by or-ing one or more message types described at *Debug message types* on page 1274.

11.3.2.4 FS_GetErrorFilter()

Description

Queries activation status of error debug messages.

Prototype

```
U32 FS_GetErrorFilter(void);
```

Return value

Value indicating the activation status for all debug message types of the error class.

Additional information

This function is optional and is available only when the file system is built with `FS_DEBUG_LEVEL` set to a value equal or greater than `FS_DEBUG_LEVEL_LOG_ERRORS`.

The return value is specified by or-ing one or more message types described at *Debug message types* on page 1274.

11.3.2.5 FS_GetLogFilter()

Description

Queries activation status of trace debug messages.

Prototype

```
U32 FS_GetLogFilter(void);
```

Return value

Value indicating the activation status for all debug message types of the trace class.

Additional information

This function is optional and is available only when the file system is built with `FS_DEBUG_LEVEL` set to a value equal or greater than `FS_DEBUG_LEVEL_LOG_ALL`.

The return value is specified by or-ing one or more message types described at *Debug message types* on page 1274.

11.3.2.6 FS_GetWarnFilter()

Description

Queries activation status of warning debug messages.

Prototype

```
U32 FS_GetWarnFilter(void);
```

Return value

Value indicating the activation status for all debug message types of the warning class.

Additional information

This function is optional and is available only when the file system is built with `FS_DEBUG_LEVEL` set to a value equal or greater than `FS_DEBUG_LEVEL_LOG_WARNINGS`.

The return value is specified by or-ing one or more message types described at *Debug message types* on page 1274.

11.3.2.7 FS_SetErrorFilter()

Description

Enables and disables error debug messages.

Prototype

```
void FS_SetErrorFilter(U32 FilterMask);
```

Parameters

Parameter	Description
<code>FilterMask</code>	Specifies the message types.

Additional information

`FS_AddErrorFilter()` can be used to enable and disable a specified set of debug message types of the error class. The debug message types that have the bit set to 1 in `FilterMask` are enabled while the other debug message types are disabled.

This function is optional and is available only when the file system is built with `FS_DEBUG_LEVEL` set to a value equal or greater than `FS_DEBUG_LEVEL_LOG_ERRORS`.

`FileMask` is specified by or-ing one or more message types described at *Debug message types* on page 1274.

11.3.2.8 FS_SetLogFilter()

Description

Enables and disables trace debug messages.

Prototype

```
void FS_SetLogFilter(U32 FilterMask);
```

Parameters

Parameter	Description
<code>FilterMask</code>	Specifies the message types.

Additional information

`FS_SetLogFilter()` can be used to enable and disable a specified set of debug message types of the trace class. The debug message types that have the bit set to 1 in `FilterMask` are enabled while the other debug message types are disabled.

This function is optional and is available only when the file system is built with `FS_DEBUG_LEVEL` set to a value equal or greater than `FS_DEBUG_LEVEL_LOG_ALL`.

`FileMask` is specified by or-ing one or more message types described at *Debug message types* on page 1274.

11.3.2.9 FS_SetWarnFilter()

Description

Enables and disables warning debug messages.

Prototype

```
void FS_SetWarnFilter(U32 FilterMask);
```

Parameters

Parameter	Description
<code>FilterMask</code>	Specifies the message types.

Additional information

`FS_SetWarnFilter()` can be used to enable and disable a specified set of debug message types of the warning class. The debug message types that have the bit set to 1 in `FilterMask` are enabled while the other debug message types are disabled.

This function is optional and is available only when the file system is built with `FS_DEBUG_LEVEL` set to a value equal or greater than `FS_DEBUG_LEVEL_LOG_WARNINGS`.

`FileMask` is specified by or-ing one or more message types described at *Debug message types* on page 1274.

11.3.2.10 Debug message types

Description

Flags that control the output of debug messages.

Definition

```
#define FS_MTYPE_INIT      (1uL << 0)
#define FS_MTYPE_API      (1uL << 1)
#define FS_MTYPE_FS       (1uL << 2)
#define FS_MTYPE_STORAGE  (1uL << 3)
#define FS_MTYPE_JOURNAL  (1uL << 4)
#define FS_MTYPE_CACHE    (1uL << 5)
#define FS_MTYPE_DRIVER   (1uL << 6)
#define FS_MTYPE_OS       (1uL << 7)
#define FS_MTYPE_MEM      (1uL << 8)
#define FS_MTYPE_BIGFAT   (1uL << 9)
#define FS_MTYPE_ADAPT    (1uL << 10)
```

Symbols

Definition	Description
FS_MTYPE_INIT	Debug messages output during the initialization.
FS_MTYPE_API	Debug messages from the API functions.
FS_MTYPE_FS	Debug messages from the file system layer.
FS_MTYPE_STORAGE	Debug messages from the storage layer.
FS_MTYPE_JOURNAL	Debug messages from the Journaling component.
FS_MTYPE_CACHE	Debug messages from the sector cache.
FS_MTYPE_DRIVER	Debug messages from the device and logical drivers.
FS_MTYPE_OS	Debug messages from the OS layer.
FS_MTYPE_MEM	Debug messages from the internal memory allocator.
FS_MTYPE_BIGFAT	Debug messages from the BigFAT component.
FS_MTYPE_ADAPT	Debug messages from emFile adaptation layers.

11.4 Troubleshooting

This section provides some ideas about how to analyze why the file system is not working as expected.

emFile comes with an API function called `FS_FOpen()` that is the equivalent of the `fopen()` function that is part of any standard C library. This function takes as parameters a file name and an access mode. If the specified file access type is allowed and no error occurs, the function returns a pointer to a file handle that can be used to perform operations on that file.

```
#include "FS.h"

int SampleFileOpen(const char * s) {
    FS_FILE * pFile;

    pFile = FS_FOpen("test.txt", "r");
    if (pFile == NULL) {
        return -1; // report error
    } else {
        return 0; // file system is up and running!
    }
}
```

If this pointer is zero after calling `FS_FOpen()`, there was a problem opening the file. There are basically three main reasons why this could happen:

- The file or path does not exist.
- The drive could not be read or written.
- The drive contains an invalid BIOS parameter block or partition table. These faults can be caused by corrupted media. To verify the validity of your medium, either check if the medium is physically okay or check the medium with another operation system (for example Windows).

There are also faults that are relatively seldom but also possible:

- A compiler/linker error has occurred.
- Stack overflow.
- Memory failure.
- Electro-magnetic influence (EMC, EMV, ESD.) To find out what the real reason for the error is, you may just try reading and writing a raw sector. Here is an example function that tries writing a single sector to your device. After reading back and verifying the sector data, you know if sector access to the device is possible and if your device is working.

```
#include "FS.h"

#define BYTES_PER_SECTOR    512

int SampleWriteSector(void) {
    U8  acBufferOut[BYTES_PER_SECTOR];
    U8  acBufferIn[BYTES_PER_SECTOR];
    U32 SectorIndex;
    int r;
    int i;
    //
    // Do not write on the first sectors. They contain
    // information about partitioning and media geometry.
    //
    SectorIndex = 80;
    //
    // Fill the buffer with data.
    //
    for (i = 0; i < BYTES_PER_SECTOR; i++) {
        acBufferOut[i] = i % 256;
    }
    //
    // Write one sector.
    //
    r = FS_STORAGE_WriteSector("", acBufferOut, SectorIndex);
    if (r) {
```

```
    FS_X_Log("Cannot write to sector.\n");
    return -1;
}
//
// Read back the sector contents.
//
r = FS_STORAGE_ReadSector("", acBufferIn, SectorIndex);
if (r) {
    FS_X_Log("Cannot read from sector.\n");
    return -1;
}
//
// Compare the sector contents.
//
for (i = 0; i < BYTES_PER_SECTOR; i++) {
    if (acBufferIn[i] != acBufferOut[i]) {
        FS_X_Log("Sector not correctly written.\n");
        return -1;
    }
}
return 0;
}
```

If you still receive no valid pointer to a file handle although the sectors of the device are accessible and other operating systems report the device to be valid, you may have to take a look into the running system by stepping through the function `FS_FOpen()`.

Chapter 12

Profiling with SystemView

This chapter describes the profiling instrumentation of emFile.

12.1 General information

emFile is instrumented to generate profiling information of API functions and driver-level functions. This profiling information expose the run-time behavior of emFile in an application, recording which API functions have been called, how long the execution took, and revealing which driver-level functions have been called by API functions or events like interrupts.

The profiling information is recorded using SystemView. SystemView is a real-time recording and visualization tool for profiling data. It exposes the true run-time behavior of a system, going far deeper than the insight provided by debuggers. This is particularly effective when developing and working with complex systems comprising an OS with multiple threads and interrupts, and one or more middle ware components.

SystemView can ensure a system performs as designed, can track down inefficiencies, and show unintended interactions and resource conflicts. The recording of profiling information with SystemView is minimally intrusive to the system and can be done on virtually any system. With SEGGERs Real Time Technology (RTT) and a J-Link SystemView can record data in real-time and analyze the data live, while the system is running.

The emFile profiling instrumentation can be easily configured and set up.

12.2 Configuring profiling

Profiling can be included or excluded at compile-time and enabled at run-time. When profiling is excluded, no additional overhead in performance or memory usage is generated. Even when profiling is enabled the overhead is minimal, due to the efficient implementation of SystemView.

The SystemView module needs to be added to the application to enable profiling. If not already part of the project, download the sources from <https://www.segger.com/systemview.html> and add them to the project.

Also make sure that the `FS_SYSVIEW.c` file from the `FS` directory of the emFile shipment is included in the project.

12.2.1 Compile time configuration

The configuration of emFile can be changed via compile time flags which can be added to `FS_Conf.h`. `FS_Conf.h` is the main configuration file of the file system.

To include profiling, the configuration define `FS_SUPPORT_PROFILE` must be set to 1 in the emFile configuration (`FS_Conf.h`) or via the project preprocessor defines.

The following table lists the configuration defines related to profiling.

Define	Type	Default value	Description
<code>FS_SUPPORT_PROFILE</code>	B	0	Enables/disables profiling support.
<code>FS_SUPPORT_PROFILE_END_CALL</code>	B	0	Enables/disables the profiling of return values.

Refer to *Configuration of emFile* on page 1218 for a description of configuration define types.

12.2.1.1 FS_SUPPORT_PROFILE

This configuration define can be used to enable the support for profiling instrumentation in emFile. By default the support is disabled to save ROM space.

12.2.1.2 FS_SUPPORT_PROFILE_END_CALL

This configuration define specifies if the return values of the profiled functions have to be recorded. This feature is disabled by default to save ROM space. `FS_SUPPORT_PROFILE_END_CALL` has effect only when `FS_SUPPORT_PROFILE` is set to 1.

For detailed information about the configuration of emFile and the types of the configuration defines, refer to *Configuration of emFile* on page 1218.

12.2.2 Runtime configuration

To enable profiling at run-time, `FS_SYSVIEW_Init()` needs to be called. Profiling can be enabled at any time but it is recommended to do this in `FS_X_AddDevices()` as demonstrated in the sample below:

```
#include "FS.h"

/*****
 *
 *      FS_X_AddDevices
 *
 *      Function description
 *      This function is called by the FS during FS_Init().
 */
void FS_X_AddDevices(void) {
    #if FS_SUPPORT_PROFILE
        FS_SYSVIEW_Init();
    #endif
}
```

```
//  
// Add device driver initialization here.  
//  
}
```

12.3 Recording and analyzing profiling information

When profiling is included and enabled emFile generates profiling events. On a system which supports RTT (i.e. ARM Cortex-M and Renesas RX) the data can be read and analyzed with SystemView and a J-Link. Connect the J-Link to the target system using the default debug interface and start the SystemView host application. If the system does not support RTT, SystemView can be configured for single-shot or postmortem mode. Please refer to the SystemView User Manual for more information.

The screenshot displays the main window of the SEGGER SystemViewer V2.36a application. The window title is "SEGGER SystemViewer V2.36a - SEGGER start project [embOS] on MK66FN2M0xxx18". The interface is divided into several sections:

- Events Table:** A table listing profiling events with columns for #, Timestamp, Context, Event, and Detail. The events are filtered to show only those from the "MainTask" context.

#	Timestamp	Context	Event	Detail
10990	05.262 489 321	MainTask	FS_LB_ReadDevice	pType=0x00016cfc Unit=0...
10991	05.262 742 500	MainTask	FS_LB_ReadDevice	returns 0x0 after 253.1...
10992	05.262 781 536	MainTask	FS_LB_WriteDevice	pType=0x00016cfc Unit=0...
10993	05.262 824 179	MainTask	FS_LB_WriteDevice	returns 0x0 after 42.6 ...
10994	05.262 831 893	MainTask	FS_FOpen	returns 0x1fff0504 afte...
10995	05.262 838 893	MainTask	FS_FSeek	pFile=0x1fff0504 Offset...
10996	05.262 845 964	MainTask	FS_FSeek	returns 0x0 after 7.0 u...
10997	05.262 851 786	MainTask	FS_SetEndOfFile	pFile=0x1fff0504
10998	05.262 867 143	MainTask	FS_LB_ReadDevice	pType=0x00016cfc Unit=0...
11003	05.264 147 750	MainTask	FS_LB_ReadDevice	returns 0x0 after 1.280...
11004	05.264 726 607	MainTask	FS_LB_WriteDevice	pType=0x00016cfc Unit=0...
11005	05.264 769 143	MainTask	FS_LB_WriteDevice	returns 0x0 after 42.5 ...
- Timeline:** A graphical representation of the events over time. The width is set to 10.0 ms. A vertical cursor is positioned at timestamp 05.262 845 964. The timeline shows various system components: Unified, SysTick, Scheduler, Timer, MainTask, and Idle. The MainTask component shows a series of green bars representing the execution of the events listed in the table above.
- Contexts:** A table listing the active contexts. The "MainTask" context is selected, showing its type as "@100" and stack information as "3072 @ 0x1fff237c".
- System:** A table showing system properties. The "Target System" is identified as "SEGGER start project" with OS "embOS", Device "MK66FN2M0xxx18", Cycle Frequency "168 000 000 Hz", and Cycle Period "6 ns".

At the bottom of the window, it indicates "28 354 Events" and "10.627 941" as the current timestamp.

Main window of SystemView

Chapter 13

Performance and resource usage

This chapter contains information about the RAM and ROM requirements and how to measure and improve performance of emFile.

13.1 Resource usage

emFile has been designed to meet the requirements of any embedded system. This means the the file system can be configured to include only the features required by a specific system in order to keep the RAM and ROM usage at a minimum while providing efficient access to the storage device.

The actual RAM and ROM memory requirements of emFile depend on the used features. The following section provides information about how to calculate the memory requirements and some values for typical applications. Note that the values are valid for the given configuration. Features can affect the size of others. For example, if FAT32 is deactivated, the format function gets smaller because the 32 bit specific part of format is not added into the final executable.

13.1.1 ROM usage

13.1.1.1 Test procedure

The ROM usage was measured by compiling the file system sources with SEGGER Embedded Studio for ARM V7.10 for a Cortex-M CPU with the size optimization enabled. The file system was configured to use the lowest debug level and the OS support was disabled:

```
#define FS_OS_LOCKING          0 // Disable OS support
#define FS_DEBUG_LEVEL        0 // Set debug level
```

No driver has been added to the file system. For information about the memory usage of a specific emFile driver refer to the "Performance and resource usage" section of the respective driver in the *Device drivers* on page 389 section.

The sample application listed below has been used to calculate the memory resources of commonly used functions. You can easily reproduce the measurement results by compile this sample application. Build the application listed below and generate a linker listing to get the memory requirements of an application which only includes startup code and the empty main() function. Afterwards, set the value of the macro STEP to 1 to get the memory requirement of the minimum file system. Subtract the ROM requirements from STEP=0 from the ROM requirements of STEP=1 to get the exact ROM requirements of a minimal file system. Increment the value of the macro STEP to include more file system functions and repeat your calculation.

FS_TEST_ROMUsage.c

```

/*****
 *                               (c) SEGGER Microcontroller GmbH           *
 *                               The Embedded Experts                       *
 *                               www.segger.com                             *
 *****/

----- END-OF-HEADER -----

File      : FS_TEST_ROMUsage.c
Purpose   : Application to calculate the ROM usage of the file system.
*/

/*****
 *
 *       #include section
 *
 *****/
*/
#include "FS.h"
#include "FS_Int.h"

#if FS_DEBUG_LEVEL > 0
    #error FS_DEBUG_LEVEL has to be to 0.
#endif

```

```

/*****
 *
 *     Defines, configurable
 *
 *****/
#ifndef STEP
#define STEP    0    // Change this line to adjust which portions of code are linked
#endif

#ifndef SUBSTEP
#define SUBSTEP  0
#endif

/*****
 *
 *     Static data
 *
 *****/
#if STEP >= 9
    static U32 _aCache[FS_SIZEOF_CACHE_ANY(2, 512) / 4];
#endif // STEP >= 9
#if (STEP >= 10)
    static U32 _aBuffer[16];
    static U8  _NumErrors;
#endif // STEP >= 10

/*****
 *
 *     Static code
 *
 *****/

#if (STEP >= 10)

/*****
 *
 *     _OnError
 */
static int _cbOnError(int ErrCode, ...) {
    (void)ErrCode;
    _NumErrors++;
    return FS_CHECKDISK_ACTION_DO_NOT_REPAIR;
}

#endif // STEP >= 10

/*****
 *
 *     Public code
 *
 *****/

/*****
 *
 *     MainTask
 */
void MainTask(void);
void MainTask(void) {
#if STEP >= 1    // Step 1: Minimum file system
    FS_FILE * pFile;

    FS_Init();
#if FS_SUPPORT_JOURNAL
    FS_JOURNAL_Create("", 100uL * 1024uL);
#endif
    pFile = FS_FOpen("File.txt", "w");
#endif
#if STEP >= 2    // Step 2: Write a file
    FS_Write(pFile, "Test", 4);
#endif
#if STEP >= 3    // Step 3: Remove a file

```

```

    FS_Remove("File.txt");
#endif
#if STEP >= 4           // Step 4: Open a directory
{
    FS_FIND_DATA fd;
    char          acFileName[16];

    FS_FindFirstFile(&fd, "", acFileName, sizeof(acFileName));
    FS_FindClose(&fd);
}
#endif
#if STEP >= 5           // Step 5: Create a directory
    FS_MkDir("TestDir");
#endif
#if STEP >= 6           // Step 6: Add long file name support
#if (FS_SUPPORT_FAT != 0)
    FS_FAT_SupportLFN();
#endif
#endif
#if STEP >= 7           // Step 7: Low-level format a storage device
    FS_FormatLow("");
#endif
#if STEP >= 8           // Step 8: High-level format a storage device
    FS_Format("", NULL);
#endif
#if STEP >= 9           // Step 9: Assign cache
#if (SUBSTEP == 0)
    FS_AssignCache("", _aCache, sizeof(_aCache), FS_CACHE_ALL);
#endif
#if (SUBSTEP == 1)
    FS_AssignCache("", _aCache, sizeof(_aCache), FS_CACHE_MAN);
#endif
#if (SUBSTEP == 2)
    FS_AssignCache("", _aCache, sizeof(_aCache), FS_CACHE_RW);
#endif
#if (SUBSTEP == 3)
    FS_AssignCache("", _aCache, sizeof(_aCache), FS_CACHE_RW_QUOTA);
#endif
#if (SUBSTEP == 4)
    FS_AssignCache("", _aCache, sizeof(_aCache), FS_CACHE_MULTI_WAY);
#endif
#endif
#if STEP >= 10          // Step 10: Disk checking
    _NumErrors = 0;
    FS_CheckDisk("", _aBuffer, sizeof(_aBuffer), 1, _cbOnError);
#endif
#if STEP >= 11          // Step 11: Get information about storage device
{
    FS_DISK_INFO DiskInfo;

    FS_GetVolumeInfo("", &DiskInfo);
}
#endif
#if STEP >= 12          // Step 12: Get the size of a file
    FS_GetFileSize(pFile);
#endif
#if STEP >= 1           // Step 1: Minimum file system
    FS_FClose(pFile);
#endif
}

/*****
 *
 *      FS_X_AddDevices
 */
void FS_X_AddDevices(void) {
    ;
}

/*****
 *
 *      FS_X_GetTimeDate
 *
 *      Description:
 *      Current time and date in a format suitable for the file system.
 */

```

```

*
*   Bit 0-4:   2-second count (0-29)
*   Bit 5-10: Minutes (0-59)
*   Bit 11-15: Hours (0-23)
*   Bit 16-20: Day of month (1-31)
*   Bit 21-24: Month of year (1-12)
*   Bit 25-31: Count of years from 1980 (0-127)
*
*/
U32 FS_X_GetTimeDate(void) {
    U32 r;
    U16 Sec, Min, Hour;
    U16 Day, Month, Year;

    Sec   = 0;           // 0 based.   Valid range: 0..59
    Min   = 0;           // 0 based.   Valid range: 0..59
    Hour  = 0;           // 0 based.   Valid range: 0..23
    Day   = 1;           // 1 based.   Means that 1 is 1. Valid range is 1..31
    (depending on month)
    Month = 1;           // 1 based.   Means that January is 1. Valid range is 1..12.
    Year  = 0;           // 1980 based. Means that 2007 would be 27.
    r     = Sec / 2 + (Min << 5) + (Hour << 11);
    r |= (U32)(Day + (Month << 5) + (Year << 9)) << 16;
    return r;
}

/***** End of file *****/

```

13.1.1.2 Test results

The following table shows the ROM usage of different API functions for the FAT file system.

Step	Substep	Description	ROM [Kbytes]
1		File system core (without driver)	9.5
2		Write file	1.1
3		Remove file	0.03
4		Open directory	0.5
5		Create directory	0.5
6		Long file name support	3.5
7		Low-level format storage device	0.3
8		High-level format storage device	1.7
9	0	Assign a cache (FS_CACHE_ALL)	0.4
9	1	Assign a cache (FS_CACHE_MAN)	0.4
9	2	Assign a cache (FS_CACHE_RW)	0.7
9	3	Assign a cache (FS_CACHE_RW_QUOTA)	1.0
9	4	Assign a cache (FS_CACHE_MULTI_WAY)	1.1
10		Disk checking	3.5
11		Get information about storage device	0.4
12		Get the size of a file.	0.05

Additional information

Typically, a simple file system uses about 10 Kbytes of ROM. To calculate the overall ROM usage, the ROM usage of the used driver(s) needs to be added.

13.1.2 Static RAM usage

Static RAM usage refers to the amount of RAM required by the file system internally for all the storage devices. **Usage: 150 bytes**

13.1.3 Dynamic RAM usage

Dynamic RAM is the amount of memory allocated by the file system at runtime. Most of the dynamic RAM is allocated during the initialization of the file system. The amount of memory allocated depends on the number of added devices, the number of simultaneously opened files and of the type of OS locking as follows:

Data structure	Size (Bytes)	Count
File handle	24 + 4 (if <code>FS_SUPPORT_FILE_BUFFER = 1</code>)	Maximum number of simultaneously open files. Depends on application, minimum is 1.
File object	46 + 2 (if <code>FS_FAT_OPTIMIZE_LINEAR_ACCESS = 1</code> or <code>FS_EFS_OPTIMIZE_LINEAR_ACCESS = 1</code>) + 6 (if <code>FS_FAT_OPTIMIZE_LINEAR_ACCESS = 2</code> or <code>FS_EFS_OPTIMIZE_LINEAR_ACCESS = 2</code>) + <code>FS_MAX_LEN_FULL_FILE_NAME</code> (if <code>FS_MULTI_HANDLE_SAFE = 1</code>) + 8 (if <code>FS_SUPPORT_ENCRYPTION = 1</code>)	Maximum number of simultaneously open files. Depends on application, minimum is 1.
Volume instance	120 + 4 (if <code>FS_SUPPORT_VOLUME_ALIAS ≠ 0</code> and <code>FS_MAX_LEN_VOLUME_ALIAS = 0</code>) + <code>FS_MAX_LEN_VOLUME_ALIAS</code> (if <code>FS_SUPPORT_VOLUME_ALIAS ≠ 0</code> and <code>FS_MAX_LEN_VOLUME_ALIAS > 0</code>)	Number of <code>FS_AddDevice()</code> calls
<code>FS_OS_LOCKING = 0</code> (no OS is used)		
Sector buffer	8 + sector size (512 bytes by default)	2 + 1 (if <code>FS_SUPPORT_ENCRYPTION = 1</code>) + 1 (if <code>FS_SUPPORT_JOURNAL = 1</code>)
<code>FS_OS_LOCKING = 1</code> (OS locking at API level)		
Sector buffer	8 + sector size (512 bytes by default)	2 + 1 (if <code>FS_SUPPORT_ENCRYPTION = 1</code>) + 1 (if <code>FS_SUPPORT_JOURNAL = 1</code>)
OS synchronization object	Depends on the OS used	1
<code>FS_OS_LOCKING = 2</code> (OS locking at driver level)		
Sector buffer	8 + sector size (512 bytes by default)	2 + 1 (if <code>FS_SUPPORT_ENCRYPTION = 1</code>) + 1 (if <code>FS_SUPPORT_JOURNAL = 1</code>) x number of <code>FS_AddDevice()</code> calls
OS synchronization object	Depends on the OS used	1 + number of <code>FS_AddDevice()</code> calls
OS locking instance	16	number of <code>FS_AddDevice()</code> calls

Note

The RAM usage of a volume instance does not include the RAM required by the device or logical driver attached to that volume. The amount of RAM required by a driver instance is documented in the "Performance and resource usage" of that driver.

Note

File handles and file objects can also be allocated after the file system initialization depending on how many files the application opens at the same time.

RAM usage example

A small file system application with the following configuration

- only one file is opened at a time
- no operating system support
- using the SD card driver

requires approximately **1300 bytes**.

13.2 Performance

A benchmark is used to measure the speed of the software on available targets. This benchmark is in no way complete, but it gives an approximation of the length of time required for common operations on various targets. You can find the measurement results in the chapter describing the individual drivers.

13.2.1 Test procedure

The performance tests are executed using the `FS_PerformanceSimple.c` application that can be found in the `{Sample/FS/Application}` folder of the emFile shipment.

The test application performs the following steps:

1. Format the drive.
2. Create and open a file for writing.
3. Start measuring of write performance.
4. Write a multiple of 8 Kbytes.
5. Stop measuring of write performance.
6. Close the file.
7. Reopen the file for reading.
8. Start measuring of read performance.
9. Read a multiple of 8 Kbytes.
10. Stop measuring of read performance.
11. Close the file.
12. Show the performance results.

FS_PerformanceSimple.c

```

/*****
*          (c) SEGGER Microcontroller GmbH          *
*          The Embedded Experts                    *
*          www.segger.com                          *
*****/
----- END-OF-HEADER -----

File      : FS_PerformanceSimple.c
Purpose   : Sample program that can be used to measure the performance
            of the file system.

Additional information:
Preparations:
  Works out-of-the-box with any storage device.

Expected behavior:
  Measures the speed at which the file system can write and read blocks
  of data to and from a file. The size of the file as well as the number
  of bytes that have to be written at once are configurable.

  The application always formats the storage device to make sure that
  the measurements are not influenced by the data already stored on the
  file system.

Sample output:
  Start
  High-level format
  Writing 4 chunks of 2048 KiB.....OK
  Reading 4 chunks of 2048 KiB.....OK

  W Speed: 9183 KiB/s
  R Speed: 18123 KiB/s
  Finished

Notes:
  The sample application may report a write or read speed of 0
  if a very fast storage device is used for the test such as a RAM disk.
  This is normal behavior and the reason for this is that the accuracy
  of the time base used for the measurements is limited to 1 ms.
  This limitation can be removed by increasing the size of the work buffer

```

```

    via the BLOCK_SIZE configuration define.
*/

/*****
*
*      #include Section
*
*****/
*/
#include <string.h>
#include "FS.h"
#include "FS_OS.h"
#include "SEGGER.h"

/*****
*
*      Defines, configurable
*
*****/
*/
#ifndef FILE_SIZE
#define FILE_SIZE          (8192L * 1024L)
    // Size of the file in bytes to be used for testing.
#endif

#ifndef BLOCK_SIZE
#define BLOCK_SIZE         (8 * 1024L)
    // Block size for individual read / write operation in bytes.
#endif

#ifndef NUM_BLOCKS_MEASURE
#define NUM_BLOCKS_MEASURE (64)
    // Number of blocks for individual measurement
#endif

#ifndef VOLUME_NAME
#define VOLUME_NAME        ""
    // Name of the volume to be used for testing.
#endif

#ifndef FILE_NAME
#define FILE_NAME          "SEGGER.txt"
    // Name of the file to be used for testing.
#endif

#ifndef USE_PREALLOCATION
#define USE_PREALLOCATION   1
    // Configures if the file preallocation has to be used.
#endif

#if FS_SUPPORT_JOURNAL
#ifndef JOURNAL_SIZE
#define JOURNAL_SIZE      0
    // Size of the Journaling file in bytes.
#endif
#endif

/*****
*
*      Types
*
*****/
*/

typedef struct {
    const char * sName;
    I32          Min;
    I32          Max;
    I32          Av;
    I32          Sum;
    I32          NumSamples;
    U32          NumBytes;
} RESULT;

/*****
*
*****/

```

```

*      Static data
*
*****
*/
static U32   _aBuffer[BLOCK_SIZE / 4];
static RESULT _aResult[2];
static int   _TestNo;
static char  _ac[512];

/*****
*
*      Static code
*
*****
*/

/*****
*
*      _WriteFile
*
*      Function description
*      Measures the write time.
*/
static I32 _WriteFile(FS_FILE * pFile, const void * pData, U32 NumBytes, U32 NumBlocksMeasure) {
    I32 t;
    U32 i;

    t = (I32)FS_X_OS_GetTime();
    for (i = 0; i < NumBlocksMeasure; i++) {
        (void)FS_Write(pFile, pData, NumBytes);
    }
    return (I32)FS_X_OS_GetTime() - t;
}

/*****
*
*      _ReadFile
*
*      Function description
*      Measures the read performance.
*/
static I32 _ReadFile(FS_FILE * pFile, void * pData, U32 NumBytes, U32 NumBlocksMeasure) {
    I32 t;
    U32 i;

    t = (I32)FS_X_OS_GetTime();
    for (i = 0; i < NumBlocksMeasure; i++) {
        (void)FS_Read(pFile, pData, NumBytes);
    }
    return (I32)FS_X_OS_GetTime() - t;
}

/*****
*
*      _StartTest
*/
static void _StartTest(const char * sName, U32 NumBytes) {
    RESULT * pResult;

    if ((_TestNo + 1) < (int)SEGGER_COUNTOF(_aResult)) {
        pResult = &_aResult[++_TestNo];
        pResult->sName      = sName;
        pResult->Min        = 0x7fffffff;
        pResult->Max        = -0x7fffffff;
        pResult->NumSamples = 0;
        pResult->Sum         = 0;
        pResult->NumBytes   = NumBytes;
    }
}

/*****
*
*      _StoreResult
*/
static void _StoreResult(I32 t) {
    RESULT * pResult;

```

```

pResult = &_aResult[_TestNo];
if (t > pResult->Max) {
    pResult->Max = t;
}
if (t < pResult->Min) {
    pResult->Min = t;
}
pResult->NumSamples++;
pResult->Sum += (I32)t;
pResult->Av = pResult->Sum / pResult->NumSamples;
}

/*****
 *
 *      _GetAverage
 */
static double _GetAverage(int Index) {
    RESULT * pResult;
    double v;
    unsigned NumKBytes;

    pResult = &_aResult[Index];
    v = (double)pResult->Av;
    if ((U32)v == 0u) {
        v = 1.0;
        // Make sure that we display the maximum speed if the timer resolution is too low.
    }
    v = (double)1000.0 / v;
    NumKBytes = pResult->NumBytes >> 10;
    v = v * (double)NumKBytes;
    return v;
}

/*****
 *
 *      Public code
 */

/*****
 *
 *      MainTask
 */
#ifdef __cplusplus
extern "C" { /* Make sure we have C-declarations in C++ programs */
#endif
void MainTask(void);
#ifdef __cplusplus
}
#endif
void MainTask(void) {
    int i;
    U32 Space;
    unsigned NumLoops;
    U32 NumBytes;
    U32 NumBytesAtOnce;
    FS_FILE * pFile;
    I32 t;
    int r;
    U32 NumBlocksMeasure;
    char acFileName[128];

    FS_X_Log("Start\n");
    FS_Init();
    _TestNo = -1;
    //
    // Check if we need to low-level format the volume
    //
    if (FS_IsLLFormatted(VOLUME_NAME) == 0) {
        FS_X_Log("Low-level format\n");
        (void)FS_FormatLow(VOLUME_NAME);
    }
    //
    // Volume is always high level formatted

```

```

// before doing any performance tests.
//
FS_X_Log("High-level format\n");
#if FS_SUPPORT_FAT
r = FS_FormatSD(VOLUME_NAME);
#else
r = FS_Format(VOLUME_NAME, NULL);
#endif // FS_SUPPORT_FAT
if (r == 0) {
#if FS_SUPPORT_JOURNAL
FS_SetFileWriteMode(FS_WRITEMODE_SAFE);
#endif
#if JOURNAL_SIZE
//
// Enable Journaling.
//
FS_JOURNAL_CreateEx(VOLUME_NAME, JOURNAL_SIZE, 1);
#endif // JOURNAL_SIZE
#else
//
// Configure the file system so that the
// directory entry and the allocation table
// are updated when the file is closed.
//
FS_SetFileWriteMode(FS_WRITEMODE_FAST);
#endif // FS_SUPPORT_JOURNAL
//
// Fill the buffer with data.
//
memset(_aBuffer, (int)'a', sizeof(_aBuffer));
//
// Get some general info.
//
Space = FS_GetVolumeFreeSpace(VOLUME_NAME);
Space = SEGGER_MIN(Space, (U32)FILE_SIZE);
NumBytesAtOnce = BLOCK_SIZE;
NumBlocksMeasure = NUM_BLOCKS_MEASURE;
for (;;) {
    NumBytes = NumBytesAtOnce * NumBlocksMeasure;
    if (NumBytes <= Space) {
        break;
    }
    NumBytesAtOnce >>= 1;
    NumBlocksMeasure >>= 1;
}
NumLoops = Space / NumBytes;
if (NumLoops != 0u) {
    //
    // Create file of full size.
    //
    _StartTest("W", NumBytes);
    SEGGER_snprintf(acFileName, (int)sizeof(acFileName), "%s%c
%s", VOLUME_NAME, FS_DIRECTORY_DELIMITER, FILE_NAME);
    pFile = FS_FOpen(acFileName, "w");
#if USE_PREALLOCATION
    //
    // Preallocate the file, setting the file pointer to the highest position
    // and declare it as the end of the file.
    //
    (void)FS_FSeek(pFile, (I32)Space, FS_SEEK_SET);
    (void)FS_SetEndOfFile(pFile);
    //
    // Set file position to the beginning.
    //
    (void)FS_FSeek(pFile, 0, FS_SEEK_SET);
#endif // USE_PREALLOCATION
    //
    // Check write performance with clusters/file size preallocated.
    //
    SEGGER_snprintf(_ac, (int)sizeof(_ac), "Writing %d chunks of %lu
KiB...", NumLoops, NumBytes >> 10);
    FS_X_Log(_ac);
    for (i = 0; i < (int)NumLoops; i++) {
        t = _WriteFile(pFile, _aBuffer, NumBytesAtOnce, NumBlocksMeasure);
        _StoreResult(t);
        FS_X_Log(".");
    }
}

```

```

FS_X_Log("OK\n");
(void)FS_FClose(pFile);
//
// Check read performance.
//
_StartTest("R", NumBytes);
SEGGER_sprintf(_ac, (int)sizeof(_ac), "Reading %d chunks of %lu
KiB.." , NumLoops, NumBytes >> 10);
FS_X_Log(_ac);
pFile = FS_FOpen(acFileName, "r");
for (i = 0; i < (int)NumLoops; i++) {
    t = _ReadFile(pFile, _aBuffer, NumBytesAtOnce, NumBlocksMeasure);
    _StoreResult(t);
    FS_X_Log(".");
}
FS_X_Log("OK\n\n");
(void)FS_FClose(pFile);
(void)FS_Remove(acFileName);
//
// Show results for performance list.
//
for (i = 0; i <= _TestNo; i++) {
    SEGGER_sprintf(_ac, (int)sizeof(_ac), "%s Speed: %d KiB/s
\n", _aResult[i].sName, (int)_GetAverage(i));
    FS_X_Log(_ac);
}
} else {
    FS_X_Log("ERROR: Not enough free space available on the storage.\n");
}
FS_Unmount(VOLUME_NAME);
} else {
    FS_X_Log("ERROR: Volume could not be formatted!\n");
}
FS_X_Log("Finished\n");
for (;;) {
    ;
}
}
}

/***** End of file *****/

```

13.2.2 How to improve performance

If you find that the performance of emFile on your hardware is not what you expect there are several ways you can improve it.

Use a different write mode

The default behavior of the file system is to update the allocation table and the directory entry after each write operation. If several write operations are performed between the opening and the closing of the file it is recommended to set the write mode to `FS_WRITE-MODE_MEDIUM` or `FS_WRITEMODE_FAST` to increase the performance. In these modes the allocation table and the directory entry are updated only when the file is closed. Refer to `FS_SetFileWriteMode()` to learn how the write mode can be configured. Please note that these write modes can not be used when journaling is enabled.

Pre-allocate the files

The pre-allocation of a file helps reduce the number of accesses to the storage device and therefore improves the read and write performance. When a file is pre-allocated the file system reserves storage space for that file in the allocation table before the file is actually filled with data. As such, a write access to the allocation table is no longer necessary when the data is actually stored to the file. A file can be pre-allocated by calling either `FS_SetEndOfFile()` or `FS_SetFileSize()` in the application after the file is opened.

Write multiples of a logical sector size

The file system implements a 0-copy mechanism in which data written to a file using the `FS_FWrite()` and `FS_Write()` functions is passed directly to the device driver if the data is written at a sector boundary and the number of bytes written is a multiple of sector size. In any other case the file system uses a read-modify-write operation which increases the number of I/O operations and reduces the performance. The file system makes sure that the content of a file always begins at a sector boundary.

Use a file buffer

It is recommended to activate the file buffering when the application reads and writes amounts of data smaller than the sector size. Refer to `FS_ConfigFileBufferDefault()` to see how this can be done. The file buffer is a small cache which helps reducing the number of times storage medium is accessed and thus increasing the performance.

Use a sector cache

The sector cache can be enabled to increase the overall performance of the file system. For more information refer to *Caching and buffering* on page 366.

Configure a read-ahead driver

The read-ahead driver is useful when a storage medium is used which is more efficient when several sectors are read or written at once. This includes storage media such as CompactFlash cards, SD and MMC cards and USB sticks. Normally, the file system reads the allocation table one sector at a time. If configured, the file system activates the read-ahead driver at runtime when the allocation table is accessed. This reduces, for example, the time it takes to determine the amount of free space. For more information refer to *Sector Read-Ahead driver* on page 1158.

Optimize the hardware layer

Ensure that the routines of the hardware layer are fast. It depends on your compiler how to do that. Some compilers have the option to define a function as running from RAM which is faster compared to running it from flash.

Use the FS_OPTIMIZE macro

The definitions of time critical functions in emFile are prefixed with the macro `FS_OPTIMIZE`. By default it expands to nothing. You can use this macro to enable the compiler optimization only for these functions. It depends on your compiler how to define this macro.

Chapter 14

Journaling

This chapter documents and explains emFile's Journaling component. The Journaling component is an extension to file system that makes the file operations fail-safe.

14.1 General information

emFile Journaling is an additional component that can be used to protect the integrity of the file system structure against an unexpected reset. The FAT and EFS file systems are by design not fail-safe therefore the usage of the Journaling component is recommended for any system that may suddenly lose power while writing data to a storage device. The Journaling component is located between the file system and the storage layer and works by temporarily storing all the data changes performed by the file system layer to a journal file. The changes are then copied at once from the journal file to the actual destination on the storage device.

14.1.1 Driver fail-safety

Data can be lost in case of unexpected reset in either the file system layer (FAT or EFS) or in the driver layer. The entire system is fail-safe only if both layers are fail safe. The Journaling component makes only sure that the file system layer fail-safe. For fail-safety of the driver layer, refer to *Device drivers* on page 389.

14.1.2 Features

- Non fail-safe file systems will be fail-safe.
- Fully compatible to standard file system implementations (e.g. FAT).
- Every type of storage device is supported. No reformat required.
- Multiple write accesses to the storage medium can be combined in user application.

14.2 Theory of operation

emFile is typically used with non fail-safe file systems like FAT. Loss of data can occur in either the driver layer or the file system layer. The driver layer is typically fail-safe therefore the only place where a typical data loss can occur is the file system layer. The file system can be corrupted when a write operation is interrupted for example in the event of power failure or system crash. This derives from the design of FAT file system and is true for all implementations from any vendor. The emFile Journaling component adds fail-safety to the file system layer.

The goal of this additional component is to guarantee a file system that is always in a consistent state. Operations on file system layer are mostly not atomic. For example, a single call to `FS_FWrite()` that writes data into a new file causes the execution of the following three storage layer operations:

1. Allocate cluster and update FAT.
2. Write user data.
3. Update directory entry.

An unexpected interrupt (such as a power failure) in this process can corrupt the file system. To prevent such corruptions the Journaling component stores every write access to achieve an always consistent state of the file system. All changes to the file system are stored in a journal file. The data stored in the journal file is copied to the actual destination on the storage device only if the file system layer operation has been finished without interruption. This procedure guarantees an always consistent state of the file system, because an interruption of the copy process does not lead to data loss. The interrupted copy process is restarted after a restart of the target hardware.

The following table lists the possible error scenarios:

	Moment of error	State	Data
1.	Journal empty	Consistent	—
2.	While writing into journal	Consistent	Lost
3.	While finalizing the journal	Consistent	Lost
4.	After finalization	Consistent	Preserved
5.	While copying from journal into file system	Consistent	Preserved
6.	After copy process, before invalidating of the journal	Consistent	Preserved
7.	While invalidating of the journal	Consistent	Preserved

14.3 Write optimization

The Journaling component has been optimized for write performance. When data is written at the end of a file, which is the case in the most applications, only the management information (allocation table and directory entry) is actually stored to journal file. The file contents is written directly to the actual destination on the storage device that helps improving the write performance. The fail-safety of the file system layer is not affected as the file contents overwrite storage blocks that are not allocated to any file or directory. The optimization is disabled as soon as a file or directory is deleted during a journal transaction. This is done in order to make sure that the data of the deleted file or directory is preserved in case of an unexpected reset.

14.4 How to use the Journaling component

Using Journaling component is very simple from the application's perspective. Only two changes have to be made to an existing application in order to enable the Journaling component:

1. The Journaling component has to be enabled in the file system configuration via the `FS_SUPPORT_JOURNAL` configuration define. Optionally, the name of the journal file can be configured via the `FS_JOURNAL_FILE_NAME` configuration define. For more information about additional compile time options refer to the section *Configuration* on page 1262.
2. The application has to call either `FS_JOURNAL_Create()` or `FS_JOURNAL_CreateEx()` after formatting the volume to create the file required for the journal operation. Refer to `FS_JOURNAL_Create()` and `FS_JOURNAL_CreateEx()` for detailed information.

Everything else is done by the Journaling component.

14.4.1 Combining multiple write operations

The Journaling component can be used in the application to create a journal transaction that consists of multiple write operations. This can be useful when for example the changes made to two different files have to be performed in an atomic way. That is after an unexpected reset that interrupts the write operation the files have to contain either the old or the new data but never a combination of both. A journal transaction can be opened via `FS_JOURNAL_Begin()` and has to be closed using `FS_JOURNAL_End()` as shown in the sample below.

```
#include "FS.h"

void SampleJournalMultipleWrite(void) {
    FS_FILE * pFile;

    //
    // Begin an operations which have to be be fail-safe.
    // All following steps will be stored into journal.
    //
    #if FS_SUPPORT_JOURNAL
        FS_JOURNAL_Begin("");
    #endif // FS_SUPPORT_JOURNAL
    pFile = FS_FOpen("File1.txt", "w");
    if (pFile) {
        FS_Write(pFile, "Test 1", 6);
        FS_FClose(pFile);
    }
    pFile = FS_FOpen("File2.txt", "w");
    if (pFile) {
        FS_Write(pFile, "Test 2", 6);
        FS_FClose(pFile);
    }
    //
    // End an operation which has to be be fail-safe.
    // Data is copied from journal into file system.
    //
    #if FS_SUPPORT_JOURNAL
        FS_JOURNAL_End("");
    #endif // FS_SUPPORT_JOURNAL
}
```

14.4.2 Preserving the consistency of a file

The Journaling component can be used in the application to protect the contents of the file against unexpected resets. This means that after an unexpected reset that interrupted the file write operation, the file will contain either the old data or the new data but not a combination of both. The same applies to the particular case where the application writes to an empty file. The first method uses `FS_JOURNAL_Begin()` and `FS_JOURNAL_End()` to create a journal transaction as shown in the next example code. The advantage of this method is that a relatively small writing buffer can be used.

```

#include "FS.h"

void SampleJournalFileConsistency1(void) {
    U8      aBuffer[128];
    FS_FILE * pFile;

    pFile = FS_FOpen("File.txt", "w");
    if (pFile) {
        #if FS_SUPPORT_JOURNAL
            FS_JOURNAL_Begin("");
        #endif // FS_SUPPORT_JOURNAL
        memset(aBuffer, 'a', sizeof(aBuffer));
        FS_Write(pFile, aBuffer, sizeof(aBuffer));
        memset(aBuffer, 'b', sizeof(aBuffer));
        FS_Write(pFile, aBuffer, sizeof(aBuffer));
        //
        // Changes are committed in a single journaling transaction
        // assuming the journal file is sufficiently large to store
        // all the changes performed by the file system.
        //
        #if FS_SUPPORT_JOURNAL
            FS_JOURNAL_End("");
        #endif // FS_SUPPORT_JOURNAL
        FS_FClose(pFile);
    }
}

```

The second method uses a buffer sufficiently large to store the contents of the entire file that is then passed to `FS_FWrite()` or `FS_Write()` in single function call. This method is demonstrated in the following example code.

```

#include "FS.h"

void SampleJournalFileConsistency2(void) {
    U8      aBuffer[256];
    FS_FILE * pFile;

    pFile = FS_FOpen("File.txt", "w");
    if (pFile) {
        memset(aBuffer, 'a', 128);
        memset(&aBuffer[128], 'b', 128);
        //
        // The changes are committed in a single journal transaction
        // assuming that the journal file is sufficiently large to
        // store all the changes.
        //
        FS_Write(pFile, aBuffer, sizeof(aBuffer));
        FS_FClose(pFile);
    }
}

```

Both methods require that the journal file is sufficiently large to store all the changes made to the storage device by the file system during the write operation. When writing to a file that is not empty the management data and the file contents are stored the journal file. If the file the application is writing to is initially empty then only the management data has to be stored to journal file. In this case the contents of the file is written directly to the actual destination on the storage device which means that a smaller journal file can be used.

14.4.3 Journaling and write caching

In order to guarantee the correct operation of the Journaling component most of the write caching performed by the file system has to be disabled. That is the file system has to be configured to write the data immediately to storage device instead of keeping the data in its internally RAM buffers. If not configured in this way, the journaling is no longer able to ensure the fail safety of the file system on an unexpected reset because the data stored in the internal RAM buffers will be lost.

The correct operation of the Journaling component is guaranteed when:

- **The sector cache in write back mode is disabled.** emFile comes with support for caching at logical sector level. The sector cache is disabled by default and it has to be explicitly enabled in the application via `FS_AssignCache()`. Five types of sector caches are provided with three of them also supporting a write mode. The `FS_CACHE_ALL` and `FS_CACHE_MAN` cache types are pure read caches and can always be used together with the Journaling component. The other three types of caches `FS_CACHE_RW`, `FS_CACHE_RW_QUOTA`, and `FS_CACHE_MULTI_WAY` can work in read as well as in write-back and write-through mode. The application has to make sure that the write-back mode is disabled for this type of sector caches. The write-through mode can be used together with the Journaling component without negatively affecting the fail-safety of the file system. For detailed information about the configuration of sector caches, refer to *Caching and buffering* on page 366.
- **The delayed update of directory entries is disabled.** The file system can be configured to update the directory entries only when the file is closed. This is done in order to increase the write performance. This feature is enabled via `FS_ConfigOnWriteDirUpdate()` with the `OnOff` parameter set to 0. The application has to make sure that this API function is not called at all or that it is called with the `OnOff` parameter set to 1.
- **The file system write mode is set to `FS_WRITEMODE_SAFE`.** emFile can be configured to use different methods when it writes data to a file. The application has to make sure that the write mode is set to `FS_WRITEMODE_SAFE`. This write mode guarantees that the data is written immediately to storage device. By default the file system uses the `FS_WRITEMODE_SAFE` write mode. The write mode can be changed at runtime via `FS_SetFileWriteMode()`. If this function is called in the application then the `WriteMode` parameter has to be set to `FS_WRITEMODE_SAFE`. Alternatively, the call to `FS_SetFileWriteMode()` can be removed.

Note

Beginning with the version 4.04g of emFile an application is allowed to use a file buffer in write mode with the Journaling component enabled without the risk of damaging the structure of a file system in case of an unexpected reset. This was not possible with versions older than 4.04g because of the way the file buffer was implemented.

14.5 Configuration

The Journaling component has to be configured at compile as well as runtime to enable its operation.

14.5.1 Compile time configuration

The configuration at compile time is realized via preprocessor defines that have to be added to the `FS_Conf.h` file which is the main configuration file of emFile. For detailed information about the configuration of emFile and of the configuration define types, refer to *Configuration of emFile* on page 1218. The following table lists the configuration defines supported by the Journaling component.

Define	Type	Default value	Description
<code>FS_SUPPORT_JOURNAL</code>	B	0	Enables or disables the Journaling component.
<code>FS_JOURNAL_FILE_NAME</code>	S	"Journal.dat"	Configures the default name of the journal file.
<code>FS_MAX_LEN_JOURNAL_FILE_NAME</code>	N	0	Configures the space reserved for the journal file name.
<code>FS_JOURNAL_ENABLE_STATS</code>	B	0	Enables or disables the support for statistical counters.
<code>FS_JOURNAL_SUPPORT_FREE_SECTOR</code>	B	1	Enables or disables the support for informing the device driver about unused logical sectors.
<code>FS_JOURNAL_SUPPORT_FAST_SECTOR_SEARCH</code>	B	1	Specifies which method to use when searching for a logical sector in the journal file.
<code>FS_JOURNAL_OPTIMIZE_SPACE_USAGE</code>	B	0	Enables or disables the efficient handling of consecutive logical sector operations.

14.5.1.1 FS_SUPPORT_JOURNAL

This define has to be set to 1 in order to enable the support for Journaling component in the file system. The journal must be initialized in the application at runtime by calling either `FS_JOURNAL_Create()` or `FS_JOURNAL_CreateEx()`.

14.5.1.2 FS_JOURNAL_FILE_NAME

This define specifies the default name of the journal file. The name of the journal file can be changed at runtime by calling `FS_JOURNAL_SetFileName()`.

14.5.1.3 FS_MAX_LEN_JOURNAL_FILE_NAME

`FS_MAX_LEN_JOURNAL_FILE_NAME` is the maximum number of characters (including the 0-terminator) in the name of the journal file. A value of 0 disables the feature which is the default. The RAM usage of a volume instance increases the number of bytes specified via this configuration define. The actual file name can be set at runtime using `FS_JOURNAL_SetFileName()`.

14.5.1.4 FS_JOURNAL_ENABLE_STATS

The support for statistical counters can be enabled or disabled by using this define. The statistical counters provide information about the operation of the Journaling component. The values of the statistical counters can be queried via `FS_JOURNAL_GetStatCounters()` and cleared via `FS_JOURNAL_ResetStatCounters()`.

14.5.1.5 FS_JOURNAL_SUPPORT_FREE_SECTOR

With this feature enabled, the Journaling component forwards information about unused logical sectors to the device driver. A device driver such as NAND or NOR driver can use this information to optimize the handling of the data. The operation has to be enabled at runtime via the `IsFreeSectorSupported` parameter of `FS_JOURNAL_CreateEx()`

14.5.1.6 FS_JOURNAL_SUPPORT_FAST_SECTOR_SEARCH

If this define set to 1 then each entry in the logical to physical mapping table of the Journaling component is 32-bit large which improves the read and write performance. At the same time setting `FS_JOURNAL_SUPPORT_FAST_SECTOR_SEARCH` to 1 it increases the RAM usage of the Journaling component.

14.5.1.7 FS_JOURNAL_OPTIMIZE_SPACE_USAGE

Setting this configuration define to 1 enables the Journaling component to group consecutive sector operations so that the space available in the journal file is used more efficiently. Especially this option helps prevent the occurrence of journal overflow events when the application deletes large files with the support for the free sector operation enabled. Enabling this option increases the RAM usage of the Journaling component.

14.5.2 Runtime configuration

The Journaling component requires a file to temporarily store the changes performed by the file system. This file has to be created at runtime after the storage device is formatted by calling either `FS_JOURNAL_Create()` or `FS_JOURNAL_CreateEx()`.

14.6 API functions

The table below lists the available API functions.

Function	Description
<code>FS_JOURNAL_Begin()</code>	Opens a journal transaction.
<code>FS_JOURNAL_Create()</code>	Creates the journal file.
<code>FS_JOURNAL_CreateEx()</code>	Creates the journal file.
<code>FS_JOURNAL_Disable()</code>	Deactivates the journal.
<code>FS_JOURNAL_Enable()</code>	Activates the journal.
<code>FS_JOURNAL_End()</code>	Closes a journal transaction.
<code>FS_JOURNAL_GetInfo()</code>	Returns information about the journal.
<code>FS_JOURNAL_GetOpenCnt()</code>	Returns the number times the current journal transaction has been opened.
<code>FS_JOURNAL_GetStatCounters()</code>	Returns statistical information about the operation.
<code>FS_JOURNAL_Invalidate()</code>	Cancel the pending journal transaction.
<code>FS_JOURNAL_IsEnabled()</code>	Checks the journal operational status.
<code>FS_JOURNAL_IsPresent()</code>	Checks the presence of journal file.
<code>FS_JOURNAL_ResetStatCounters()</code>	Sets to 0 all statistical counters.
<code>FS_JOURNAL_SetFileName()</code>	Configures the name of the journal file.
<code>FS_JOURNAL_SetOnOverflowExCallback()</code>	Registers a callback function for the journal full event.
<code>FS_JOURNAL_SetOnOverflowCallback()</code>	Registers a callback function for the journal full event.

14.6.1 FS_JOURNAL_Begin()

Description

Opens a journal transaction.

Prototype

```
int FS_JOURNAL_Begin(const char * sVolumeName);
```

Parameters

Parameter	Description
<code>sVolumeName</code>	Journal instance identified by volume name (0-terminated string).

Return value

= 0 OK, journal transaction opened.
 ≠ 0 Error code indicating the failure reason.

Additional information

This function is optional. The file system opens and closes journal transactions automatically as required. The application can use this function together with `FS_JOURNAL_End()` to create journal transactions that extend over multiple file system operations. A journal transaction can be opened more than once using `FS_JOURNAL_Begin()` and it has to be closed by calling `FS_JOURNAL_End()` by the same number of times.

Following the call to `FS_JOURNAL_Begin()` all the data written by the application is stored to the journal file until either the application calls `FS_JOURNAL_End()` or the journal becomes full. An application can get informed about a journal full event by registering a callback function via `FS_JOURNAL_SetOnOverflowCallback()` or `FS_JOURNAL_SetOnOverflowExCallback()`

It is mandatory that `FS_JOURNAL_Begin()` and `FS_JOURNAL_End()` are called in pairs. The calls to these functions can be nested. The current nesting level can be queried via `FS_JOURNAL_GetOpenCnt()`.

Example

```
#include "FS.h"

void SampleJournalBegin(void) {
    FS_FILE * pFile;

    #if FS_SUPPORT_JOURNAL
        FS_JOURNAL_Begin("");           // Open the journal transaction.
    #endif // FS_SUPPORT_JOURNAL
    pFile = FS_FOpen("File1.txt", "w");
    if (pFile) {
        FS_Write(pFile, "Test 1", 6);
        FS_FClose(pFile);
    }
    pFile = FS_FOpen("File2.txt", "w");
    if (pFile) {
        FS_Write(pFile, "Test 2...", 6);
        FS_FClose(pFile);
    }
    pFile = FS_FOpen("File3.txt", "w");
    if (pFile) {
        FS_Write(pFile, "Test 3...", 6);
        FS_FClose(pFile);
    }
    #if FS_SUPPORT_JOURNAL
        FS_JOURNAL_End("");           // Close the journal transaction.
    #endif // FS_SUPPORT_JOURNAL
}
```

```
}
```

14.6.2 FS_JOURNAL_Create()

Description

Creates the journal file.

Prototype

```
int FS_JOURNAL_Create(const char * sVolumeName,
                    U32      NumBytes);
```

Parameters

Parameter	Description
<code>sVolumeName</code>	Journal instance identified by volume name (0-terminated string).
<code>NumBytes</code>	Size of journal file in bytes.

Return value

- = 1 OK, journal already exists.
- = 0 OK, journal successfully created.
- < 0 Error code indicating the failure reason.

Additional information

This function is mandatory. It has to be called after the file system initialization to create the journal file. `FS_JOURNAL_Create()` does nothing if the journal file already exists. The name of the journal file can be configured at compile time via `FS_JOURNAL_FILE_NAME` or at runtime via `FS_JOURNAL_SetFileName()`.

The size of the journal file can be calculated by using the following formula:

$$\text{JournalSize} = 3 * \text{BytesPerSector} + (16 + \text{BytesPerSector}) * \text{NumSectors}$$

Parameter	Description
<code>JournalSize</code>	Size of the journal file in bytes. This value has to be passed as second parameter to <code>FS_JOURNAL_Create()</code> or <code>FS_JOURNAL_CreateEx()</code> .
<code>BytesPerSector</code>	Size of the file system logical sector in bytes.
<code>NumSectors</code>	Number of logical sectors the journal has to be able to store.

The number of sectors the journal file is able to store on a transaction depends on the file system operations performed by the application. The table below can be used to calculate the approximate number of sectors that are stored during a specific file system operation.

API function	Number of logical sectors
<code>FS_CreateDir()</code>	The number of sectors modified by <code>FS_MkDir()</code> times the number of directories that have to be created.
<code>FS_DeleteDir()</code>	The number of sectors modified by <code>FS_Rmdir()</code> times the number of directories that have to be deleted plus the number of sectors modified by <code>FS_Remove()</code> times the number of files that have to be deleted.
<code>FS_FClose()</code>	One sector if the file has been modified else no sectors.
<code>FS_FOpen()</code>	One sector when creating the file else no sectors. If the file exists and is truncated to 0 then total number of sectors in the allocation table that have to be modified.
<code>FS_FWrite()</code>	The same number of sectors as <code>FS_Write()</code>
<code>FS_MkDir()</code>	Two sectors plus the number of sectors in cluster.

API function	Number of logical sectors
FS_ModifyFileAttributes()	One sector.
FS_Move()	Two sectors if the destination and source files or directories are located on the same volume else the number of sectors modified by FS_CopyFile().
FS_Remove()	One sector plus total number of sectors in the allocation table that have to be modified.
FS_Rename()	One sector.
FS_Rmdir()	Two sectors.
FS_SetEndOfFile()	One sector plus the total number of sectors in the allocation table that have to be modified.
FS_SetFileAttributes()	One sector.
FS_SetFileSize()	The same number of sectors as FS_SetEndOfFile()
FS_SetFileTime()	One sector.
FS_SetFileTimeEx()	One sector.
FS_SetVolumeLabel()	One sector.
FS_SyncFile()	One sector if the file has been modified else no sectors.
FS_SetVolumeLabel()	One sector.
FS_Write()	Uses the remaining free space in the journal file at the start of the transaction. Two sectors and about 9 percent of the free space available in the journal file (rounded up to a multiple of sector size) are reserved for allocation table and directory entry updates. The remaining sectors are used to store the actual data. If more data is written than free space is available in the journal file, the operation is split into multiple journal transactions.

The values in the table above are for orientation only. The recommended procedure for determining the size of the journal file is as follows:

Step	Action
1	Set the journal file to an arbitrary value (for example 200 Kbytes)
2	Let the application perform typical file system operations.
3	Verify if any journal overflow events occurred. If yes, then increase the journal file by a multiple of the logical sector size of the volume on which the journal file is stored and go to step 2.
4	Done

An overflow event is reported by the Journaling component by invoking the callback function registered via either `FS_JOURNAL_SetOnOverflowExCallback()` or `FS_JOURNAL_SetOnOverflowCallback()`. In addition, the size of the journal file can be fine tuned by evaluating the value of the `MaxWriteSectorCnt` member of the `FS_JOURNAL_STAT_COUNTERS` returned via `FS_JOURNAL_GetStatCounters()`.

If a journal is created using `FS_JOURNAL_Create()` the information about unused logical sectors is not forwarded to the device driver. `FS_JOURNAL_CreateEx()` can be used instead to specify how this information has to be handled.

The journal operation remains disabled after the journal creation if the application previously disabled it via `FS_JOURNAL_Disable()`. In this case the journal operation has to be explicitly enabled by the application after the journal creation via `FS_JOURNAL_Enable()`.

Example

```
#include "FS.h"

void SampleJournalCreate(void) {
#if FS_SUPPORT_JOURNAL
    //
    // Create journal of 200 Kbytes on the first volume of the file system.
    //
    FS_JOURNAL_Create("", 200 * 1024);
#endif // FS_SUPPORT_JOURNAL
}
```

14.6.3 FS_JOURNAL_CreateEx()

Description

Creates the journal file.

Prototype

```
int FS_JOURNAL_CreateEx(const char * sVolumeName,
                       U32      NumBytes,
                       U8      IsFreeSectorSupported);
```

Parameters

Parameter	Description
<code>sVolumeName</code>	Journal instance identified by volume name (0-terminated string).
<code>NumBytes</code>	Size of journal file in bytes.
<code>IsFreeSectorSupported</code>	Handling of the information about unused sectors. <ul style="list-style-type: none"> • 1 Forwarded to the device driver • 0 Not forwarded to device driver.

Return value

= 1 OK, journal already exists.
 = 0 OK, journal successfully created.
 < 0 Error code indicating the failure reason.

Additional information

This function is mandatory. It performs the same operations as `FS_JOURNAL_Create()`. In addition, `IsFreeSectorSupported` can be used to specify if the information about the logical sectors that are no longer in use has to be passed to the device driver. The NOR and NAND drivers as well as the SD/MMC driver with eMMC as storage device can use this information to improve the write performance.

Example

```
#include "FS.h"

void SampleJournalCreateEx(void) {
  #if FS_SUPPORT_JOURNAL
    //
    // Create a journal file of 100 Kbytes on the first volume of the file system.
    // The journal component is configured to inform the device driver about
    // logical sectors that are no longer used by the file system.
    //
    FS_JOURNAL_CreateEx("", 100 * 1024, 1);
  #endif // FS_SUPPORT_JOURNAL
}
```

14.6.4 FS_JOURNAL_Disable()

Description

Deactivates the journal.

Prototype

```
int FS_JOURNAL_Disable(const char * sVolumeName);
```

Parameters

Parameter	Description
sVolumeName	Journal instance identified by volume name (0-terminated string).

Return value

= 0 OK, the journal operation is disabled.
 ≠ 0 Error code indicating the failure reason.

Additional information

This function is optional. FS_JOURNAL_Disable() can be used to disable the journal if the next file system operations do not have to be protected against unexpected resets. After the call to this function the integrity of the file system is no more guaranteed. The journal operation can be re-enabled by calling FS_JOURNAL_Enable().

The operational status of the journal can be queried using FS_JOURNAL_IsEnabled().

Example

```
#include "FS.h"

void SampleJournalDisableEnable(void) {
    FS_FILE * pFile;

    #if FS_SUPPORT_JOURNAL
        FS_JOURNAL_Disable("");
    #endif // FS_SUPPORT_JOURNAL
    //
    // The following file system operations are not fail safe.
    //
    pFile = FS_FOpen("File1.txt", "w");
    if (pFile) {
        FS_Write(pFile, "Test 1", 6);
        FS_FClose(pFile);
    }
    #if FS_SUPPORT_JOURNAL
        FS_JOURNAL_Enable("");
    #endif // FS_SUPPORT_JOURNAL
    //
    // The following file system operations are fail safe.
    //
    pFile = FS_FOpen("File2.txt", "w");
    if (pFile) {
        FS_Write(pFile, "Test 2...", 6);
        FS_FClose(pFile);
    }
}
```

14.6.5 FS_JOURNAL_Enable()

Description

Activates the journal.

Prototype

```
int FS_JOURNAL_Enable(const char * sVolumeName);
```

Parameters

Parameter	Description
<code>sVolumeName</code>	Journal instance identified by volume name (0-terminated string).

Return value

= 0 OK, the journal operation is enabled.
 ≠ 0 Error code indicating the failure reason.

Additional information

This function is optional. The journal is enabled automatically when the file system is mounted if a valid journal file is found. `FS_JOURNAL_Enable()` can be used to re-enable the journal after the application disabled it via `FS_JOURNAL_Disable()`.

After the call to `FS_JOURNAL_Enable()` all file system operations are protected against unexpected resets.

The operational status of the journal can be queried using `FS_JOURNAL_IsEnabled()`.

Example

```
#include "FS.h"

void SampleJournalDisableEnable(void) {
    FS_FILE * pFile;

    #if FS_SUPPORT_JOURNAL
        FS_JOURNAL_Disable("");
    #endif // FS_SUPPORT_JOURNAL
    //
    // The following file system operations are not fail safe.
    //
    pFile = FS_FOpen("File1.txt", "w");
    if (pFile) {
        FS_Write(pFile, "Test 1", 6);
        FS_FClose(pFile);
    }
    #if FS_SUPPORT_JOURNAL
        FS_JOURNAL_Enable("");
    #endif // FS_SUPPORT_JOURNAL
    //
    // The following file system operations are fail safe.
    //
    pFile = FS_FOpen("File2.txt", "w");
    if (pFile) {
        FS_Write(pFile, "Test 2...", 6);
        FS_FClose(pFile);
    }
}
```

14.6.6 FS_JOURNAL_End()

Description

Closes a journal transaction.

Prototype

```
int FS_JOURNAL_End(const char * sVolumeName);
```

Parameters

Parameter	Description
<code>sVolumeName</code>	Journal instance identified by volume name (0-terminated string).

Return value

= 0 OK, journal transaction closed.
 ≠ 0 Error code indicating the failure reason.

Additional information

This function is optional. The file system opens and closes journal transactions automatically as required. The application can use this function together with `FS_JOURNAL_Begin()` to create journal transactions that extend over multiple file system operations.

Following the outermost call to `FS_JOURNAL_End()` the sector data stored to journal file is copied to actual destination on the storage device. The other nested calls to `FS_JOURNAL_End()` simply close the transaction at that nesting level but do not copy any data.

It is mandatory that `FS_JOURNAL_Begin()` and `FS_JOURNAL_End()` are called in pair. The calls to these functions can be nested. The current nesting level can be queried via `FS_JOURNAL_GetOpenCnt()`.

Example

```
#include "FS.h"

void SampleJournalBegin(void) {
    FS_FILE * pFile;

    #if FS_SUPPORT_JOURNAL
        FS_JOURNAL_Begin("");           // Open the journal transaction.
    #endif // FS_SUPPORT_JOURNAL
    pFile = FS_FOpen("File1.txt", "w");
    if (pFile) {
        FS_Write(pFile, "Test 1", 6);
        FS_FClose(pFile);
    }
    pFile = FS_FOpen("File2.txt", "w");
    if (pFile) {
        FS_Write(pFile, "Test 2...", 6);
        FS_FClose(pFile);
    }
    pFile = FS_FOpen("File3.txt", "w");
    if (pFile) {
        FS_Write(pFile, "Test 3...", 6);
        FS_FClose(pFile);
    }
    #if FS_SUPPORT_JOURNAL
        FS_JOURNAL_End("");           // Close the journal transaction.
    #endif // FS_SUPPORT_JOURNAL
}
```

14.6.7 FS_JOURNAL_GetInfo()

Description

Returns information about the journal.

Prototype

```
int FS_JOURNAL_GetInfo(const char          * sVolumeName,
                      FS_JOURNAL_INFO * pInfo);
```

Parameters

Parameter	Description
<code>sVolumeName</code>	Journal instance identified by volume name (0-terminated string).
<code>pInfo</code>	out Journal information.

Return value

= 0 OK, information returned.
 < 0 Error code indicating the failure reason.

Additional information

This function is optional. The application can call it to get information about the journal such as if the journal is enabled, the number of free sectors in the journal and so on.

`FS_JOURNAL_GetInfo()` mounts the specified volume if the auto mount feature is enabled for that volume and the volume is not mounted at the time of the call.

14.6.8 FS_JOURNAL_GetOpenCnt()

Description

Returns the number times the current journal transaction has been opened.

Prototype

```
int FS_JOURNAL_GetOpenCnt(const char * sVolumeName);
```

Parameters

Parameter	Description
<code>sVolumeName</code>	Journal instance identified by volume name (0-terminated string).

Return value

- ≥ 0 OK, number of nested calls.
- ≠ 0 Error code indicating the failure reason.

Additional information

This function is optional. The application can use `FS_JOURNAL_GetOpenCnt()` to check how many times `FS_JOURNAL_Begin()` has been called in a row without a call to `FS_JOURNAL_End()` in between.

14.6.9 FS_JOURNAL_GetStatCounters()

Description

Returns statistical information about the operation.

Prototype

```
int FS_JOURNAL_GetStatCounters(const char          * sVolumeName,
                               FS_JOURNAL_STAT_COUNTERS * pStat);
```

Parameters

Parameter	Description
<code>sVolumeName</code>	Journal instance identified by volume name (0-terminated string).
<code>pStat</code>	out Statistical information.

Return value

= 0 OK, information returned.
 ≠ 0 Error code indicating the failure reason.

Additional information

This function is optional. It can be used to get information about the number of operations performed by the journal since the last file system mount operation or since the last call to `FS_JOURNAL_ResetStatCounters()`.

`FS_JOURNAL_GetStatCounters()` is available only when the file system is compiled with either `FS_JOURNAL_ENABLE_STATS` set to 1 or with `FS_DEBUG_LEVEL` set to a value equal to or larger than `FS_DEBUG_LEVEL_CHECK_ALL`.

14.6.10 FS_JOURNAL_Invalidate()

Description

Cancels the pending journal transaction.

Prototype

```
int FS_JOURNAL_Invalidate(const char * sVolumeName);
```

Parameters

Parameter	Description
<code>sVolumeName</code>	Journal instance identified by volume name (0-terminated string).

Return value

≥ 0 OK, journal data has been discarded.
 ≠ 0 Error code indicating the failure reason.

Additional information

This function is optional. It can be used to discard all the modifications stored in the journal during a journal transaction opened via `FS_JOURNAL_Begin()`. After the call to `FS_JOURNAL_Invalidate()` the current journal transaction is closed. In case of a journal transaction opened multiple times it is not necessary to call `FS_JOURNAL_Invalidate()` for the number of times the journal transaction has been opened.

A read sector cache has to be invalidated after canceling a journal transaction via `FS_JOURNAL_Invalidate()`. The application can configure a read sector cache via `FS_AssignCache()`.

Example

```
#include "FS.h"

static int _GetData(U8 * pData) {
    int NumBytes;

    NumBytes = -1;
    //
    // ...
    //
    return NumBytes;
}

void SampleJournalInvalidate(void) {
    int IsError;
    FS_FILE * pFile;
    U8 abBuffer[16];
    int NumBytes;
    IsError = 0;
    //
    // Begin the journal transaction.
    //
#ifdef FS_SUPPORT_JOURNAL
    FS_JOURNAL_Begin("");
#endif // FS_SUPPORT_JOURNAL
    //
    // Create the file and write to it.
    //
    pFile = FS_FOpen("Test.txt", "w");
    if (pFile) {
        while (1) {
            //
            // Get the data from an external source.
            //
            NumBytes = _GetData(abBuffer);
```

```
    if (NumBytes == 0) {
        FS_FClose(pFile);
        break; // No more data available.
    }
    if (NumBytes < 0) {
        IsError = 1;
        break; // Error, could not get data.
    }
    //
    // Write the data to file.
    //
    FS_Write(pFile, abBuffer, (U32)NumBytes);
}
//
// Close the transaction.
//
#ifdef FS_SUPPORT_JOURNAL
    if (IsError) {
        FS_JOURNAL_Invalidate("");
    } else {
        FS_JOURNAL_End("");
    }
#endif // FS_SUPPORT_JOURNAL
}
```

14.6.11 FS_JOURNAL_IsEnabled()

Description

Checks the journal operational status.

Prototype

```
int FS_JOURNAL_IsEnabled(const char * sVolumeName);
```

Parameters

Parameter	Description
<code>sVolumeName</code>	Journal instance identified by volume name (0-terminated string).

Return value

- = 1 The journal is active. All the file system operations are fail safe.
- = 0 The journal is not active. The file system operations are not fail safe.
- < 0 Error code indicating the failure reason.

Additional information

This function is optional. The journal is automatically activated at file system mount if a valid journal file is present. The journal file can be created using `FS_JOURNAL_Create()` or `FS_JOURNAL_CreateEx()`. The journal can be enabled and disabled at runtime using `FS_JOURNAL_Enable()` and `FS_JOURNAL_Disable()` respectively.

14.6.12 FS_JOURNAL_IsPresent()

Description

Checks the presence of journal file.

Prototype

```
int FS_JOURNAL_IsPresent(const char * sVolumeName);
```

Parameters

Parameter	Description
<code>sVolumeName</code>	Journal instance identified by volume name (0-terminated string).

Return value

- = 1 OK, journal file is present and valid.
- = 0 OK, journal file is not present.
- < 0 Error code indicating the failure reason.

Additional information

This function is optional. The application can call it to check if a journal file is present on the specified volume and that the file is also valid.

`FS_JOURNAL_IsPresent()` mounts the specified volume if the auto mount feature is enabled for that volume and the volume is not mounted at the time of the call.

14.6.13 FS_JOURNAL_ResetStatCounters()

Description

Sets to 0 all statistical counters.

Prototype

```
int FS_JOURNAL_ResetStatCounters(const char * sVolumeName);
```

Parameters

Parameter	Description
<code>sVolumeName</code>	Journal instance identified by volume name (0-terminated string).

Return value

= 0 OK, statistical counters cleared.
 ≠ 0 Error code indicating the failure reason.

Additional information

This function is optional. The statistical counters are cleared each time the volume is mounted. An application can use `FS_JOURNAL_ResetStatCounters()` to explicitly clear the statistical counters at runtime for example for testing purposes. The statistical counters can be queried via `FS_JOURNAL_GetStatCounters()`

`FS_JOURNAL_ResetStatCounters()` is available only when the file system is compiled with either `FS_JOURNAL_ENABLE_STATS` set to 1 or with `FS_DEBUG_LEVEL` set to a value equal to or larger than `FS_DEBUG_LEVEL_CHECK_ALL`.

14.6.14 FS_JOURNAL_SetFileName()

Description

Configures the name of the journal file.

Prototype

```
int FS_JOURNAL_SetFileName(const char * sVolumeName,  
                           const char * sFileName);
```

Parameters

Parameter	Description
<code>sVolumeName</code>	Journal instance identified by volume name (0-terminated string).
<code>sFileName</code>	Name of the journal file (0-terminated string)

Return value

= 0 OK, file name set.
≠ 0 Error code indicating the failure reason.

Additional information

This function is optional. It can be used by an application to specify at runtime a name for the journal file. `FS_JOURNAL_SetFileName()` has to be called before the creation of the journal file via `FS_JOURNAL_Create()` or `FS_JOURNAL_CreateEx()`.

`FS_JOURNAL_SetFileName()` is available only when the file system is compiled with the `FS_MAX_LEN_JOURNAL_FILE_NAME` configuration define set to a value greater than 0.

14.6.15 FS_JOURNAL_SetOnOverflowExCallback()

Description

Registers a callback function for the journal full event.

Prototype

```
void FS_JOURNAL_SetOnOverflowExCallback  
(FS_JOURNAL_ON_OVERFLOW_EX_CALLBACK * pfOnOverflow);
```

Parameters

Parameter	Description
pfOnOverflow	Function to be invoked when the journal full event occurs.

Additional information

This function is optional. A journal full event occurs when there is no more free space in the journal file to store the modifications requested by the file system layer. When this event occurs, the data currently stored in the journal is copied to the actual destination on the storage device to make free space for the new data. This behavior can be changed via the return value of the callback function. Refer to `FS_JOURNAL_ON_OVERFLOW_EX_CALLBACK` for more information.

The file system is no longer fail safe in the time interval from the occurrence of the journal full event to the end of current journal transaction.

14.6.16 FS_JOURNAL_SetOnOverflowCallback()

Description

Registers a callback function for the journal full event.

Prototype

```
void FS_JOURNAL_SetOnOverflowCallback  
    (FS_JOURNAL_ON_OVERFLOW_CALLBACK * pfOnOverflow);
```

Parameters

Parameter	Description
<code>pfOnOverflow</code>	Function to be invoked when the journal full event occurs.

Additional information

This function is optional. A journal full event occurs when there is no more free space in the journal file to store the modifications requested by the file system layer. When this event occurs, the data currently stored in the journal is copied to the actual destination on the storage device to make free space for the new data.

The file system is no longer fail safe in the time interval from the occurrence of the journal full event to the end of current journal transaction.

14.6.17 FS_JOURNAL_INFO

Description

Information about the journal.

Type definition

```
typedef struct {
    U8   IsEnabled;
    U8   IsFreeSectorSupported;
    U16  OpenCnt;
    U32  NumSectors;
    U32  NumSectorsFree;
} FS_JOURNAL_INFO;
```

Structure members

Member	Description
IsEnabled	Set to 1 if the journal is used to protect the integrity of the file system structure.
IsFreeSectorSupported	Set to 1 if the journal has been configured to forward "free sector" requests to device driver.
OpenCnt	Number of times the current transaction has been opened.
NumSectors	Number of logical sectors that can be stored in the journal.
NumSectorsFree	Number of logical sectors that do not store any file system data.

Additional information

The information about the journal can be queried via `FS_JOURNAL_GetInfo()`

[NumSectorsFree](#) is always smaller than or equal to [NumSectors](#). The difference between [NumSectors](#) and [NumSectorsFree](#) represents the number of logical sectors that can still be stored to journal without causing a journal overflow.

[IsEnabled](#) and [OpenCnt](#) values are identical to the values returned by `FS_JOURNAL_IsEnabled()` and `FS_JOURNAL_GetOpenCnt()` respectively.

14.6.18 FS_JOURNAL_ON_OVERFLOW_EX_CALLBACK

Description

Prototype of the function that is called on a journal overflow event.

Type definition

```
typedef int (FS_JOURNAL_ON_OVERFLOW_EX_CALLBACK)
           (const FS_JOURNAL_OVERFLOW_INFO * pOverflowInfo);
```

Parameters

Parameter	Description
<code>pOvrflowInfo</code>	Information related to the overflow event.

Return value

- 0 The journal transaction has to continue to completion.
- 1 The journal transaction has to be aborted with an error.

Additional information

This type of callback function can be registered using `FS_JOURNAL_SetOnOverflowExCallback()`.

The return value indicates the journal module how to proceed when an overflow event occurs.

14.6.19 FS_JOURNAL_ON_OVERFLOW_CALLBACK

Description

Prototype of the function that is called on a journal overflow event.

Type definition

```
typedef void (FS_JOURNAL_ON_OVERFLOW_CALLBACK)(const char * sVolumeName);
```

Parameters

Parameter	Description
<code>sVolumeName</code>	Name of the volume on which the overflow event occurred.

Additional information

This type of callback function can be registered using `FS_JOURNAL_SetOnOverflowCallback()`.

14.6.20 FS_JOURNAL_OVERFLOW_INFO

Description

Information about a journal overflow event.

Type definition

```
typedef struct {  
    U8 VolumeIndex;  
} FS_JOURNAL_OVERFLOW_INFO;
```

Structure members

Member	Description
VolumeIndex	Index of the volume on which the journal overflow occurred.

Additional information

This type of information is returned via a callback of type `FS_JOURNAL_ON_OVERFLOW_EX_CALLBACK` when a journal overflow event occurs.

14.6.21 FS_JOURNAL_STAT_COUNTERS

Description

Journal statistical counters.

Type definition

```
typedef struct {
    U32 WriteSectorCnt;
    U32 NumTransactions;
    U32 FreeSectorCnt;
    U32 OverflowCnt;
    U32 WriteSectorCntStorage;
    U32 ReadSectorCntStorage;
    U32 MaxWriteSectorCnt;
    U32 FreeSectorCntStorage;
    U32 FreeOperationCntStorage;
} FS_JOURNAL_STAT_COUNTERS;
```

Structure members

Member	Description
WriteSectorCnt	Number of sectors written by the file system to journal.
NumTransactions	Number of journal transactions performed.
FreeSectorCnt	Number of sectors freed by the file system and recorded to journal.
OverflowCnt	Number of times the journal was cleaned before the end of a transaction.
WriteSectorCntStorage	Number of sectors written by the journal to the storage device.
ReadSectorCntStorage	Number of sectors read by the journal from the storage device.
MaxWriteSectorCnt	Maximum number of sectors written by the file system to journal file in any journal transaction.
FreeSectorCntStorage	Number of sectors freed by journal on the storage device.
FreeOperationCntStorage	Number of free sector operations performed by the journal on the storage device.

Additional information

The statistical counters can be queried via `FS_JOURNAL_GetStatCounters()`. The application can use `FS_JOURNAL_ResetStatCounters()` to set all the statistical counters to 0.

[MaxWriteSectorCnt](#) can be used to fine tune the size of the journal file by comparing its value with the number of sectors that can be stored in the journal file. The number of sectors that can be stored in the journal file can be read via `FS_JOURNAL_GetInfo()`.

14.7 Performance and resource usage

This section describes the memory requirements (RAM and ROM) of the Journaling component as well as the read and write performance.

14.7.1 ROM usage

The ROM usage depends on the compiler options, the compiler version and the used CPU. The following values were measured as described in the section *Test procedure* on page 1283.

Usage: 3.3 Kbytes

14.7.2 Static RAM usage

The static RAM usage represents the amount of RAM required by the Journaling component to store static variables. The number of bytes can be seen in the list file of the compiled Journaling component.

Usage: 16 bytes

14.7.3 Dynamic RAM usage

The dynamic RAM usage is the amount of RAM allocated by the Journaling component at runtime. The number of bytes allocated depends on the journal size and on the number of volumes on which the Journaling component is enabled. The approximate runtime RAM usage of the Journaling component can be calculated as follows:

$$\text{MemAllocated} = (\text{JournalSize} / (\text{BytesPerSector} + 16) * 4 + 56) * \text{NumVolumes}$$

Parameter	Description
MemAllocated	Number of bytes allocated
JournalSize	Size of the journal file in bytes. This is the second parameter specified in the call to <code>FS_JOURNAL_Create()</code> <code>FS_JOURNAL_CreateEx()</code>
NumVolumes	Number of volumes on which the journaling is active

14.7.4 Performance

These performance measurements are in no way complete, but they give an approximation of the length of time required for common operations on various targets. The tests were performed as described in the section *Performance and resource usage* on page 384 section.

All speed values are in Kbytes/second.

CPU type	Storage device	Write speed	Reed speed
NXP LPC2478 (57.6 MHz)	SST SST39VF201 (1x16 bit, no "write burst")	5.6	2534
ST STM32F103 (72 MHz)	ST M29W128 (1x16, with "write burst", 64 bytes)	18.5	7877

14.8 FAQs

Q: Can a journal be created when other files are already present on the disk?

A: Yes. The Journaling component saves the data in a regular file called per default "Journal.dat". If there is sufficient space left on the storage device there is no problem to create the journal even if other files are present.

Q: Can the journal file be recreated?

A: Yes. Follow this procedure to recreate the journal:

- Remove the journal file via `FS_Remove()`
- Unmount the file system via `FS_Unmount()` or `FS_UnmountForced()`
- Mount the file system via `FS_Mount()` or `FS_MountEx()`
- Re-create the journal file via `FS_JOURNAL_Create()` or `FS_JOURNAL_CreateEx()`
- Re-initialize the file system via `FS_DeInit()` and `FS_Init()` if the size of the journal file is increased.

Q: Can a journal be deleted?

A: Yes, by deleting the journal file.

Q: What if the journal isn't sufficiently large?

A: If the journal is not sufficiently large the data already present in the journal file is copied to the actual destination on the storage device in order to make room for the new data.

Q: Can multiple tasks use a journal at the same time?

A: Yes, the journal is multitasking safe.

Q: Can `FS_JOURNAL_Begin()` and `FS_JOURNAL_End()` be nested?

A: Yes. The Journaling component maintains an open counter that is incremented each time `FS_JOURNAL_Begin()` is called and is decremented with each call to `FS_JOURNAL_End()`. When the open counter reaches zero the data is copied from journal file to the actual destination on the storage device and the journal transaction is terminated.

Chapter 15

Encryption

This chapter documents the emFile Encryption component. The component can be used to stored the data in a secure way.

15.1 General information

emFile Encryption is an additional component which can be used to secure the data of the entire volume or of individual files. Without encryption support all data is stored in a readable form. Using the Encryption component the data can be made unreadable before using a secret key being stored to the storage device. Without the knowledge of the secret key it is not possible to make the data readable again.

The main features of the Encryption component are:

- Can be used with both FAT and EFS file systems.
- All storage types such as NAND, NOR, SD/MMC/CompactFlash cards are supported.
- Only minor changes of application are required.
- DES and AES with 128-bit and 256-bit key lengths are supported.
- Encryption of entire storage device or of individual files.
- An utility is available to decrypt/encrypt files on a PC.
- Two packages are available: Encryption (DES) and Extra Strong Encryption (DES and AES¹)

¹ AES encryption algorithm is subject to export regulations

15.2 How to use encryption

Using file encryption is very simple from the application's perspective. The following changes have to be made to an existing application in order to enable the encryption of individual files:

1. Enable file encryption in the emFile configuration. Refer to Compile time configuration for detailed information.
2. Call `FS_CRYPT_Prepare()` to initialize an encryption object. This operation has to be performed only once. Refer to `FS_CRYPT_Prepare()` for detailed information.
3. Open a file and call `FS_SetEncryptionObject()` to assign the encryption object to file handle. Refer to `FS_SetEncryptionObject()` for detailed information.

The actual encryption and decryption is performed by the Encryption component when the application accesses the file contents via the file read and write API functions.

Note

The application has to make sure that the size of an encrypted file is always a multiple of the cryptographic algorithm block size (16 bytes for DES and AES) so that the last bytes in the file are encrypted with that cryptographic algorithm. Otherwise the value of the last unaligned bytes stored in the file is only scrambled.

Example usage

This sample function opens a file and writes a text message to it. The file contents are encrypted using the DES encryption algorithm. The changes required to an application to support encryption are marked with the comment: `// Required for encryption`.

```
#include "FS.h"

void SampleEncryptionFile(void) {
    FS_FILE * pFile;
#ifdef FS_SUPPORT_ENCRYPTION
    const U8 aKey[8] = {1, 2, 3, 4}; // Required for encryption
    FS_CRYPT_OBJ CryptObj; // Required for encryption
    static FS_DES_CONTEXT _Context; // Required for encryption
    static int _IsInited; // Required for encryption
#endif // FS_SUPPORT_ENCRYPTION

#ifdef FS_SUPPORT_ENCRYPTION
    //
    // Create the encryption object. It contains all the necessary information
    // for the encryption/decryption of data. This step must be performed only once.
    //
    if (_IsInited == 0) { // Required for encryption
        FS_CRYPT_Prepare(&CryptObj, &FS_CRYPT_ALGO_DES, // Required for encryption
            &Context, 512, aKey); // Required for encryption
        _IsInited = 1; // Required for encryption
    }
#endif // FS_SUPPORT_ENCRYPTION
    pFile = FS_FOpen("cipher.bin", "w");
    if (pFile) {
#ifdef FS_SUPPORT_ENCRYPTION
        //
        // Assign the created encryption object to file handle.
        //
        FS_SetEncryptionObject(pFile, &CryptObj); // Required for encryption
#endif // FS_SUPPORT_ENCRYPTION
        //
        // Write data to file using encryption. The message
        // is padded with '\n' characters to a multiple of
        // DES block size (16 bytes).
        //
        FS_Write(pFile, "This message has been encrypted using "
            "SEGGER emFile.\n\n\n\n\n\n\n\n\n\n", 64);
        FS_FClose(pFile);
    }
}
```

15.3 Additional information

The encryption component also supports the encryption of entire volumes. For more information refer to *Encryption driver* on page 1154.

15.4 Compile time configuration

The configuration of emFile can be changed via compile time flags that can be added to `FS_Conf.h` which is the main configuration file of the file system.

Define	Type	Default value	Description
<code>FS_SUPPORT_ENCRYPTION</code>	B	0	Specifies whether support for the file encryption should be compiled in or not.

For detailed information about the configuration of emFile and of the configuration define types, refer to *Configuration of emFile* on page 1218.

15.5 API functions

The following table lists the available API functions.

Function	Description
<code>FS_CRYPT_Prepare()</code>	Initializes the object required for the encryption/decryption of file contents.
<code>FS_CRYPT_Decrypt()</code>	Decrypts the specified number of bytes.
<code>FS_CRYPT_Encrypt()</code>	Encrypts the specified number of bytes.
<code>FS_SetEncryptionObject()</code>	Assigns an encryption object to a file handle.

15.5.1 FS_CRYPT_Prepare()

Description

Initializes the object required for the encryption/decryption of file contents.

Prototype

```
int FS_CRYPT_Prepare(      FS_CRYPT_OBJ      * pCryptObj,
                          const FS_CRYPT_ALGO_TYPE * pAlgoType,
                          void          * pContext,
                          U32          BytesPerBlock,
                          const U8     * pKey);
```

Parameters

Parameter	Description
pCryptObj	Instance of the object to be initialized.
pAlgoType	in Encryption algorithm to be used.
pContext	in Data for the encryption algorithm.
BytesPerBlock	Size of the block to encrypt/decrypt at once.
pKey	in Password for data encryption.

Return value

= 0 OK, object initialized successfully.
 ≠ 0 Error code indicating the failure reason.

Additional information

This function has to be called once for each encryption object. [pAlgoType](#) is a pointer to one of the following structures:

Algorithm type	Description
FS_CRYPT_ALGO_DES	Data Encryption Standard with 56-bit key length
FS_CRYPT_ALGO_AES128	Advanced Encryption Standard with 128-bit key length
FS_CRYPT_ALGO_AES256	Advanced Encryption Standard with 256-bit key length

The [pContext](#) parameter points to a structure of type `FS_DES_CONTEXT` when the `FS_CRYPT_ALGO_DES` algorithm is specified or to `FS_AES_CONTEXT` structure when the `FS_CRYPT_ALGO_AES128` or the `FS_CRYPT_ALGO_AES256` are specified. The context pointer is saved to object structure and must point to a valid memory location as long as the encryption object is in use.

[BytesPerBlock](#) is a power of two value that has to be smaller than or equal to the logical sector size of the volume that stores the file to be encrypted or decrypted.

The number of bytes in [pKey](#) depends on the algorithm type as follows:

Algorithm type	Size in bytes
FS_CRYPT_ALGO_DES	8
FS_CRYPT_ALGO_AES128	16
FS_CRYPT_ALGO_AES256	32

The encryption object can be shared between different files.

Example

Refer to *How to use encryption* on page 1336.

15.5.2 FS_CRYPT_Decrypt()

Description

Decrypts the specified number of bytes.

Prototype

```
int FS_CRYPT_Decrypt(const FS_CRYPT_OBJ * pCryptObj,
                    U8 * pDest,
                    const U8 * pSrc,
                    U32 NumBytes,
                    U32 * pBlockIndex);
```

Parameters

Parameter	Description
<code>pCryptObj</code>	in The instance of the encryption object.
<code>pDest</code>	out Decrypted data (plain text).
<code>pSrc</code>	in Data to be decrypted (cipher text).
<code>NumBytes</code>	Number of bytes to decrypt.
<code>pBlockIndex</code>	in Index of the decrypted data block. out Index of the next block to be decrypted.

Return value

- = 0 OK, object initialized successfully.
- ≠ 0 Error code indicating the failure reason.

Additional information

This function can be used on a host computer to decrypt a file encrypted on a target system using the encryption component. On a target system the data is decrypted automatically by the file system. `pBlockIndex` can be used to start the decryption at an arbitrary block index inside the file. The size of the block is the value passed to `BytesPerBlock` in the call to `FS_CRYPT_Prepare()` that was used to initialize the encryption object.

Example

For an example usage refer to the source code of the `FSFileEncrypter.exe` utility located in the `Windows\Fs\Fs_FileEncrypter\Src` folder of the emFile shipment.

15.5.3 FS_CRYPT_Encrypt()

Description

Encrypts the specified number of bytes.

Prototype

```
int FS_CRYPT_Encrypt(const FS_CRYPT_OBJ * pCryptObj,
                    U8 * pDest,
                    const U8 * pSrc,
                    U32 NumBytes,
                    U32 * pBlockIndex);
```

Parameters

Parameter	Description
pCryptObj	in The instance of the encryption object.
pDest	out Encrypted data (cipher text).
pSrc	in Data to be encrypted (plain text).
NumBytes	Number of bytes to encrypt.
pBlockIndex	in Index of the encrypted data block. out Index of the next block to be encrypted.

Return value

- = 0 OK, object initialized successfully.
- ≠ 0 Error code indicating the failure reason.

Additional information

This function can be used on a host computer to encrypt a file that can be later decrypted on a target system using the encryption component. On a target system the data is decrypted automatically by the file system when the application reads the data from file. [pBlockIndex](#) can be used to start the encryption at an arbitrary block index inside the file. The size of the block is the value passed to BytesPerBlock in a call to [FS_CRYPT_Prepare\(\)](#) that was used to initialize the encryption object.

Example

For an example usage refer to the source code of the `FSFileEncrypter.exe` utility located in the `Windows\Fs\Fs_FileEncrypter\Src` folder of the emFile shipment.

15.5.4 FS_SetEncryptionObject()

Description

Assigns an encryption object to a file handle.

Prototype

```
int FS_SetEncryptionObject(FS_FILE      * pFile,  
                           FS_CRYPT_OBJ * pCryptObj);
```

Parameters

Parameter	Description
<code>pFile</code>	Handle to opened file.
<code>pCryptObj</code>	Instance of the object to be initialized.

Return value

= 0 OK, configured the object to be used for file encryption.
≠ 0 Error code indicating the failure reason.

Additional information

This function has to be called once immediately after the file has been opened and before any other operation on that file. The pointer to encryption object is saved internally by the file system to the file handle. This means that the memory it points to has to remain valid until the file is closed or until the `FS_SetEncryptionObject()` is called for the same file handle with `pCryptObj` set to NULL.

The encryption object can be initialized using `FS_CRYPT_Prepare()`.

Example

Refer to *How to use encryption* on page 1336.

15.5.5 FS_CRYPT_ALGO_TYPE

Description

Encryption algorithm API.

Type definition

```
typedef struct {
    FS_CRYPT_ALGO_TYPE_PREPARE * pfPrepare;
    FS_CRYPT_ALGO_TYPE_ENCRYPT * pfEncrypt;
    FS_CRYPT_ALGO_TYPE_DECRYPT * pfDecrypt;
    U16                          BitsPerBlock;
} FS_CRYPT_ALGO_TYPE;
```

Structure members

Member	Description
pfPrepare	Initializes the operation of the algorithm.
pfEncrypt	Encrypts a block of data.
pfDecrypt	Decrypts a block of data.
BitsPerBlock	Number of bits processed at once by the algorithm.

Additional information

[BitsPerBlock](#) is set for example to 128 for the AES algorithm and to 64 for the DES algorithm.

15.5.6 FS_CRYPT_ALGO_TYPE_PREPARE

Description

Initializes the operation of the algorithm.

Type definition

```
typedef void FS_CRYPT_ALGO_TYPE_PREPARE(      void * pContext,  
                                             const U8 * pKey);
```

Parameters

Parameter	Description
<code>pContext</code>	Algorithm-specific data.
<code>pKey</code>	Encryption key.

Additional information

This function is a member of the `FS_CRYPT_ALGO_TYPE` cryptographic algorithm. It initializes the operation of the cryptographic algorithm such as key expansion. `FS_CRYPT_ALGO_TYPE_PREPARE` is called from `FS_CRYPT_Prepare()`.

15.5.7 FS_CRYPT_ALGO_TYPE_ENCRYPT

Description

Encrypts a data block.

Type definition

```
typedef void FS_CRYPT_ALGO_TYPE_ENCRYPT(
    void * pContext,
    U8 * pDest,
    const U8 * pSrc,
    U32 NumBytes,
    U32 BlockIndex);
```

Parameters

Parameter	Description
<code>pContext</code>	Algorithm-specific data.
<code>pDest</code>	<code>out</code> Encrypted data (ciphertext).
<code>pSrc</code>	<code>in</code> Data to be encrypted (plaintext).
<code>NumBytes</code>	Number of bytes to be encrypted.
<code>BlockIndex</code>	Index of the data block to be encrypted.

Additional information

This function is a member of the `FS_CRYPT_ALGO_TYPE` cryptographic algorithm. It encrypts the specified data block using the key specified in the call to `FS_CRYPT_Prepare()`.

`NumBytes` is always a multiple of the encryption block size specified via `BitsPerBlock` of `FS_CRYPT_ALGO_TYPE`.

`BlockIndex` is set to the index of the logical sector that stores the data being encrypted. It can be used for example as initialization vector for AES and DES cryptographic algorithms.

15.5.8 FS_CRYPT_ALGO_TYPE_DECRYPT

Description

Decrypts a data block.

Type definition

```
typedef void FS_CRYPT_ALGO_TYPE_DECRYPT(
    void * pContext,
    U8 * pDest,
    const U8 * pSrc,
    U32 NumBytes,
    U32 BlockIndex);
```

Parameters

Parameter	Description
<code>pContext</code>	Algorithm-specific data.
<code>pDest</code>	out Decrypted data (plaintext).
<code>pSrc</code>	in Data to be decrypted (ciphertext).
<code>NumBytes</code>	Number of bytes to be decrypted.
<code>BlockIndex</code>	Index of the data block to be decrypted.

Additional information

This function is a member of the `FS_CRYPT_ALGO_TYPE` cryptographic algorithm. It decrypts the specified data block using the key specified in the call to `FS_CRYPT_Prepare()`.

`NumBytes` is always a multiple of the encryption block size specified via `BitsPerBlock` of `FS_CRYPT_ALGO_TYPE`.

`BlockIndex` is set to the index of the logical sector that stores the data being encrypted. It can be used for example as initialization vector for AES and DES cryptographic algorithms. `BlockIndex` is set to the same value passed to `FS_CRYPT_ALGO_TYPE_ENCRYPT` when encrypting the same data block.

15.6 Encryption utility

emFile comes with command line utilities that allow the encryption and decryption of files on a host PC. Due to export regulations of encryption software two separate executables are provided that support cryptographic algorithms with different strengths.

FSFileEncrypter.exe supports only the encryption algorithms with a key length smaller than or equal to 56-bit that are not subject to any export regulations. This utility supports only the DES cryptographic algorithm.

Encryption and decryption of files with any key length can be done using the FSFileEncrypterES.exe utility that supports the DES as well as the AES cryptographic algorithms.

15.6.1 Using the file encryption utility

The utilities can be invoked directly from the command line or via a batch file. In order to use the utility directly, a terminal window must be opened first. First, the name of the executable either FSFileEncrypter.exe or FSFileEncrypterES.exe, has to be input on the command line followed by optional and required arguments. By pressing the Enter key the utility starts the encryption or decryption operation as specified.

Below is a screen shot of the FSFileEncrypter.exe utility that is invoked to decrypt the contents of the file des.bin. The decrypted plain text is placed into the file des.txt. The used cryptographic algorithm is DES as specified via the -a option. Information about the decrypting process is displayed on the terminal window. In case of an error, a message is displayed indicating the failure reason and the utility returns with a status of 1. No destination file is created in this case.

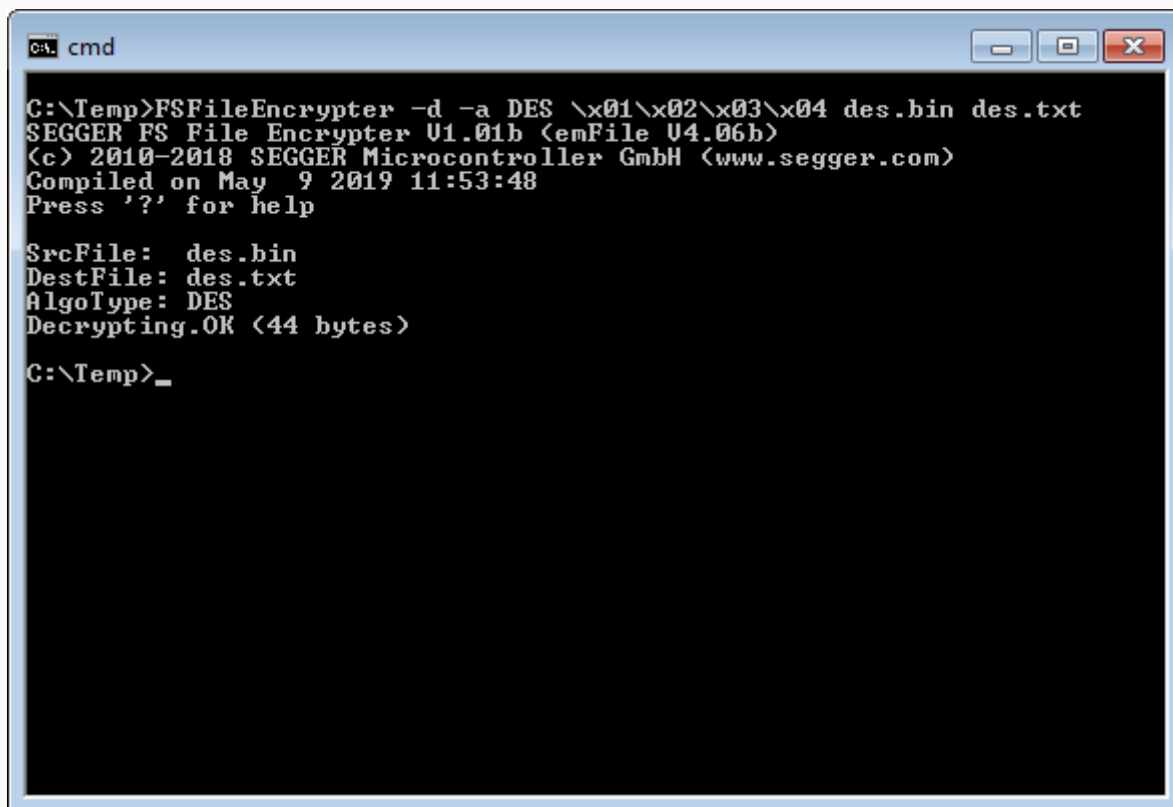

```
cmd
C:\Temp>FSFileEncrypter -d -a DES \x01\x02\x03\x04 des.bin des.txt
SEGGGER FS File Encrypter U1.01b (emFile U4.06b)
(c) 2010-2018 SEGGGER Microcontroller GmbH (www.segger.com)
Compiled on May 9 2019 11:53:48
Press '?' for help

SrcFile: des.bin
DestFile: des.txt
AlgoType: DES
Decrypting.OK (44 bytes)

C:\Temp>_
```

DES decryption

15.6.2 Command line options

The following table lists the parameters which can be omitted when invoking the utilities.

Option	Description
-a	Selects the encryption algorithm.
-b	Sets the size of the encryption block.
-d	Performs decryption.
-h	Shows the usage message and exits.
-q	Suppresses log information.
-v	Shows version information and exits.

15.6.2.1 -a

Description

Selects the encryption algorithm. Default encryption algorithm is DES.

Syntax

-a <AlgoType>

Additional information

The following table lists all valid values for AlgoType:

Type	Description
DES	Data Encryption Standard, 56-bit key length.
AES128	Advanced Encryption Standard, 128-bit key length (supported only by FSFileEncrypterES.exe)
AES256	Advanced Encryption Standard, 256-bit key length (supported only by FSFileEncrypterES.exe)

Example

Shows how to encrypt the contents of the file `plain.txt` file to `cipher.bin` file using the DES cryptographic algorithm. The encryption key is the string `secret`.

```
C:>FSFileEncrypter -a DES secret plain.txt cipher.bin
```

15.6.2.2 -b

Description

Sets the size of the encryption block. Default block size is 512 bytes.

Syntax

-b <BlockSize>

Additional information

The parameter has to be a power of two value and represents the number of bytes in the block. The block size has to be equal to the value passed to `BytesPerBlock` in the call to `FS_CRYPT_Prepare()` function that was used to initialize the encryption object on the target application.

Example

Shows how to encrypt the contents of the file `plain.txt` file to `cipher.bin` file using the DES cryptographic algorithm. The encryption key is the string `secret` and the size of the encryption block is 2048 bytes.

```
C:>FSFileEncrypter -b 2048 secret plain.txt cipher.bin
```

15.6.2.3 -d

Description

Performs decryption. Default is encryption.

Syntax

-d

Example

Shows how to decrypt the contents of the file `cipher.bin` to the `plain.txt` file using the DES cryptographic algorithm. The encryption key is the string `secret`.

```
FSFileEncrypter -d secret cipher.bin plain.txt
```

15.6.2.4 -h

Description

Shows the usage message and exits.

Syntax

-h

Example

```
C:>FSFileEncrypterES -h
DESCRIPTION
  File encryption and decryption utility for SEGGER emFile.
USAGE
  FSFileEncrypterES [-a <AlgoType>] [-b <BlockSize>]
    [-d] [-h] [-q] [-v] <Key> <SrcFile> <DestFile>
OPTIONS
  -a <AlgoType>  Type of the encryption algorithm. AlgoType can be one of:
                  DES      Data Encryption Standard, 56-bit key length
                  AES128  Advanced Encryption Standard, 128-bit key length
                  AES256  Advanced Encryption Standard, 256-bit key length
                  Default is DES.
  -b <BlockSize> Number of bytes to be encrypted/decrypted at once.
                  BlockSize must be a power of 2 value. When encrypting a file
                  BlockSize must be smaller than or equal to the sector size
                  of the file system volume. When decrypting a file, BlockSize
                  must be equal to the value used to encrypt the file.
                  Default is 512 bytes.
  -d             Perform decryption. Default is encryption.
  -h            Show this help information.
  -q            Do not show log messages.
  -v            Show version information.
ARGUMENTS
  <Key>         Encryption or decryption key as ASCII string. Non-printable
                  characters can be specified as 2 hexadecimal characters
                  prefixed by the sequence '\x'.
                  Ex: the key value 1234 can be specified as \x04\xD2.
  <SrcFile>    Path to file to be encrypted or decrypted.
  <DestFile>   Path to encrypted or decrypted file.
```

15.6.2.5 -q

Description

Suppresses log information. Default is to log messages to console.

Syntax

-q

15.6.2.6 -v

Description

Shows version information and exits.

Syntax

-v

Example

```
C:>FSFileEncrypterES -v
SEGGER FS File Encrypter (Extra Strong) V1.01a ('?' or '-h' for help)
Compiled on Sep  4 2012 16:18:23
```

15.6.3 Command line arguments

The following table lists the mandatory parameters. They must be specified on the command line in the order they are described in this table.

Parameter	Description
<Key>	A string which specifies the encryption key.
<SrcFile>	Path to the file to read from.
<DestFile>	Path to the file to write to.

15.6.3.1 <Key>

Description

A string which specifies the encryption key. Non-printable characters can be input in hexadecimal form by prefixing them with the string \x. The key is case sensitive.

Example

The file `plain.txt` is encrypted using DES cryptographic algorithm and the result is stored to the `cipher.bin` file. The password looks like this in binary form: `0x70 0x61 0x73 0x73 0x01 0x02 0x03 0x04`.

```
C:>FSFileEncrypterES pass\x01\x02\x03\x04 plain.txt cipher.bin
```

15.6.3.2 <SrcFile>

Description

Path to the file to read from.

Additional information

It specifies the plain text file in case encryption is performed. When decrypting this parameter specifies the encrypted file. The parameters `SrcFile` and `DestFile` must specify two different files.

Example

Shows how to encrypt the contents of the file `plain.txt` to the file `cipher.bin` using the AES cryptographic algorithm. `plain.txt` is the source file.

```
C:>FSFileEncrypterES -a AES128 pass plain.txt cipher.bin
```

15.6.3.3 <DestFile>

Description

Path to the file to write to.

Additional information

It specifies the cipher text file in case encryption is performed. When decrypting this parameter specifies the plain text file. The parameters `SrcFile` and `DestFile` must specify two different files.

Example

Shows how to decrypt the contents of the file `cipher.bin` to the file `plain.txt` using the AES cryptographic algorithm. `plain.txt` is the destination file.

```
C:>FSFileEncrypterES -d -a AES256 pass cipher.bin plain.txt
```

15.7 Performance and resource usage

This section describes the memory requirements (RAM and ROM) of the encryption component as well as the read and write performance. This section lists only the values for the encryption at the file level. Refer to *Performance and resource usage* on page 1157 for the performance and resource usage of volume encryption.

15.7.1 ROM usage

The ROM usage depends on the compiler options, the compiler version and the used CPU. The following values were measured as described in the section *Test procedure* on page 1283.

Usage: 0.4 Kbytes

In addition, one of the following cryptographic algorithms is required:

Algorithm type	ROM usage
FS_CRYPT_ALGO_DES	3.2 Kbytes
FS_CRYPT_ALGO_AES128	12 Kbytes
FS_CRYPT_ALGO_AES256	12 Kbytes

15.7.2 Static RAM usage

Static RAM usage is the amount of RAM required by the encryption component for static variables. The encryption component does not allocate any static variables.

15.7.3 Dynamic RAM usage

Dynamic RAM usage is the amount of RAM allocated by the encryption component at run-time. The encryption component requires one sector buffer for the encryption and decryption of data. The size of a sector buffer is by default 512 bytes. This value can be changed in the application via `FS_SetMaxSectorSize()`.

15.7.4 Performance

These performance measurements are in no way complete, but they give an approximation of the length of time required for common operations on various targets. The tests were performed as described in the section *Performance* on page 1289.

All values are in Kbytes/second.

CPU type	Storage device	Write speed	Reed speed
NXP Kinetis K60 (120 MHz)	NAND flash interfaced via 8-bit bus using AES with an 128-bit key.	522	553
ST STM32F4 (96 MHz)	SD card as storage medium using AES with an 128-bit key	500	530

Chapter 16

BigFAT

This chapter describes the component for files larger than 4GB.

16.1 General information

The FAT and EFS file systems are not able to handle files larger than 4 Gbytes because the size of the file is stored as a 32-bit value. The BigFAT component can be used in a target application to remove this limitation. Using the BigFAT component a target application can create, read, write and otherwise perform typical operations on files larger than 4GB. This is done by distributing the data across fragment files smaller than 4GB. The created fragment files are compatible with the file system on which they are stored.

The main features of the BigFAT component are:

- Can be used with both FAT and EFS file systems.
- Supports all storage types such as NAND, NOR, SD cards, and USB drives.
- Utility available to merge or split files on a PC.

16.2 Theory of operation

BigFAT is built on top of the FAT and EFS file systems. It splits the data of a file that grows larger than 4GB into smaller files. Consequently, they can be stored to the file system as regular files. The file system operations are redirected to the appropriate file, depending on the file position that is accessed by the embedded application.

Files with a size smaller than 4GB - 128KB are treated like regular files. In this case, the file access works as in a standard file system implementation. As soon as the file grows above the limit, the file gets extended. An extended file consists of one base file and one or more continuation files. The continuation files are stored in the same directory as the base file, with the name derived from the name of the base file plus an additional file extension. The name of the base file remains unchanged. The file extension of a continuation file has the format `.<Index>.BigFAT`, where the Index is a three digit decimal number. The index of the first continuation file is set to one and it increases by one with each additional continuation file. BigFAT requires support for long file names on the underlying file system layer in order to be able to apply the additional file extension of continuation files.

When the base file grows larger than 4GB - 128KB, the first continuation file is created. This procedure is required in order to guarantee that the first byte in the continuation file is aligned to a logical sector boundary. This helps increase the performance of the file system accessing the file data. The same procedure is applied when the first continuation file exceeds the 4GB - 128KB limit, with the second continuation file being created and so on.

16.3 Configuration

The BigFAT component can optionally be configured at compile time and does not have to be configured at runtime. However, the application has to make sure that the support for long file names is enabled via `FS_FAT_SupportLFN()` if the BigFAT files are located on a FAT-formatted volume. This is not necessary for EFS-formatted volumes because EFS comes with native support for long file names.

16.3.1 Compile time configuration

The handle to an opened BigFAT file stores the fully qualified name of the file. The maximum number of characters in the file name including the 0-terminator is configured via the `FS_MAX_LEN_FULL_FILE_NAME` configuration define. By default, `FS_MAX_LEN_FULL_FILE_NAME` is set to a value that works with most of the applications. `FS_MAX_LEN_FULL_FILE_NAME` can be set to a smaller value to save RAM space if the paths to the BigFAT files accessed by the application are not longer than that value.

16.4 API functions

The table below lists the available API functions.

Function	Description
<code>FS_BIGFAT_CheckDisk()</code>	Checks the consistency of the file system structure.
<code>FS_BIGFAT_Close()</code>	Closes a big file.
<code>FS_BIGFAT_Copy()</code>	Duplicates a big file.
<code>FS_BIGFAT_FindClose()</code>	Ends a directory scanning operation.
<code>FS_BIGFAT_FindFirst()</code>	Initiates a directory scanning operation and returns information about the first file or directory.
<code>FS_BIGFAT_FindNext()</code>	Returns information about the next file or directory in a directory scanning operation.
<code>FS_BIGFAT_GetInfo()</code>	Returns information about a big file.
<code>FS_BIGFAT_GetPos()</code>	Returns the read and write position in the big file.
<code>FS_BIGFAT_GetSize()</code>	Returns the size of the big file.
<code>FS_BIGFAT_GetTime()</code>	Gets the timestamp of a big file.
<code>FS_BIGFAT_ModifyAttr()</code>	Modifies file attributes.
<code>FS_BIGFAT_Move()</code>	Changes the location and the name of a big file.
<code>FS_BIGFAT_Open()</code>	Opens a big file.
<code>FS_BIGFAT_Read()</code>	Reads data from the big file.
<code>FS_BIGFAT_Remove()</code>	Deletes a big file.
<code>FS_BIGFAT_SetPos()</code>	Changes the access position in the big file.
<code>FS_BIGFAT_SetSize()</code>	Increases or reduces the size of a big file.
<code>FS_BIGFAT_SetTime()</code>	Sets the timestamp of a big file.
<code>FS_BIGFAT_Sync()</code>	Saves cached information to storage device.
<code>FS_BIGFAT_Write()</code>	Writes data to the big file.

16.4.1 FS_BIGFAT_CheckDisk()

Description

Checks the consistency of the file system structure.

Prototype

```
int FS_BIGFAT_CheckDisk(const char          * sVolumeName,
                       void                * pBuffer,
                       U32                  BufferSize,
                       int                  MaxRecursionLevel,
                       FS_CHECKDISK_ON_ERROR_CALLBACK * pfOnError);
```

Parameters

Parameter	Description
<code>sVolumeName</code>	Name of the volume to be checked.
<code>pBuffer</code>	Work buffer to be used for checking the allocation table.
<code>BufferSize</code>	Size of the work buffer in bytes. It cannot be NULL.
<code>MaxRecursionLevel</code>	The maximum directory depth the function is allowed to check.
<code>pfOnError</code>	Function that has to be called when an error is found. It cannot be NULL.

Return value

<code>= FS_CHECKDISK_RETVAL_OK</code>	No errors found or the callback returned <code>FS_CHECKDISK_ACTION_DO_NOT_REPAIR</code> .
<code>= FS_CHECKDISK_RETVAL_RETRY</code>	An error has been found. The error has been corrected since the callback function returned <code>FS_CHECKDISK_ACTION_SAVE_CLUSTERS</code> or <code>FS_CHECKDISK_ACTION_DELETE_CLUSTERS</code> . <code>FS_CheckDisk()</code> has to be called again to check for the next error.
<code>= FS_CHECKDISK_RETVAL_ABORT</code>	The application requested the abort of disk checking operation through the callback returning <code>FS_CHECKDISK_ACTION_ABORT</code> .
<code>= FS_CHECKDISK_RETVAL_MAX_RECURSE</code>	Maximum recursion level reached. The disk checking operation has been aborted.
<code>< 0</code>	Error code indicating the failure reason.

Additional information

This function performs the same operation as `FS_CheckDisk()` with the difference that it checks big files for defects. In addition to `FS_CheckDisk()`, `FS_BIGFAT_CheckDisk()` is able to detect the following errors:

- missing fragment file.
- fragment file without a corresponding base file.
- fragment file with invalid size.

These checks are performed after the call to `FS_CheckDisk()`.

Refer to `FS_CheckDisk()` for more information about the usage of this function.

Example

```
#include <stdio.h>
```

```

#include <stdarg.h>
#include <string.h>
#include "FS.h"

static U32 _aBuffer[1024 / 4];
static int _NumErrors;

/*****
 *
 *      _OnError
 */
int _OnError(int ErrCode, ...) {
    va_list    ParamList;
    const char * sFormat;
    char       c;
    char       ac[256];

    (void)memset(&ParamList, 0, sizeof(ParamList));
    sFormat = FS_CheckDisk_ErrCode2Text(ErrCode);
    if (sFormat) {
        va_start(ParamList, ErrCode);
        vsprintf(ac, sFormat, ParamList);
        FS_X_Log(ac);
        FS_X_Log("\n");
    }
    if (ErrCode != FS_CHECKDISK_ERRCODE_CLUSTER_UNUSED) {
        FS_X_Log(" Do you want to repair this? (y/n/a)");
    } else {
        FS_X_Log(" * Convert lost cluster chain into file (y)\n"
                " * Delete cluster chain (d)\n"
                " * Do not repair (n)\n"
                " * Abort (a) ");
        FS_X_Log("\n");
    }
    _NumErrors++;
    c = getchar();
    FS_X_Log("\n");
    if ((c == 'y') || (c == 'Y')) {
        return FS_CHECKDISK_ACTION_SAVE_CLUSTERS;
    } else if ((c == 'a') || (c == 'A')) {
        return FS_CHECKDISK_ACTION_ABORT;
    } else if ((c == 'd') || (c == 'D')) {
        return FS_CHECKDISK_ACTION_DELETE_CLUSTERS;
    }
    return FS_CHECKDISK_ACTION_DO_NOT_REPAIR; // Do not repair anything.
}

/*****
 *
 *      SampleBigFATCheckDisk
 */
void SampleBigFATCheckDisk(void) {
    int r;

    while (1) {
        r = FS_BIGFAT_CheckDisk("", _aBuffer, sizeof(_aBuffer), 5, _OnError);
        if (r != FS_CHECKDISK_RETVAL_RETRY) {
            break;
        }
    }
    if (_NumErrors == 0) {
        FS_X_Log("No errors were found.\n");
    } else {
        FS_X_Log("Errors were found.\n");
    }
}

```

16.4.2 FS_BIGFAT_Close()

Description

Closes a big file.

Prototype

```
int FS_BIGFAT_Close(FS_BIGFAT_FILE * pBigFile);
```

Parameters

Parameter	Description
<code>pBigFile</code>	File handle that identifies the opened file.

Return value

= 0 OK, file closed.
 ≠ 0 Error code indicating the failure reason.

Additional information

The application has to call `FS_BIGFAT_Close()` after it no longer needs to access the big file. `FS_BIGFAT_Close()` frees all the file system resources allocated to the opened file.

`pBigFile` has to point to a structure that was successfully initialized via a call to `FS_BIFILE_Open()`. After the call to `FS_BIGFAT_Close()` the file handle `pBigFile` is no longer valid and the memory allocated for it can be released by the application. The application can also use `pBigFile` as parameter to `FS_BIFILE_Open()` to open a file again.

Example

```
#include "FS.h"

void SampleBigFATClose(void) {
    FS_BIGFAT_FILE BigFile;
    int            r;

    //
    // Opens a file for reading and then closes it.
    //
    r = FS_BIGFAT_Open(&BigFile, "Test.txt", FS_BIGFAT_OPEN_FLAG_READ);
    if (r == 0) {

        //
        // Perform read accesses to file
        //

        FS_BIGFAT_Close(&BigFile);
    }
}
```

16.4.3 FS_BIGFAT_Copy()

Description

Duplicates a big file.

Prototype

```
int FS_BIGFAT_Copy(const char * sFileNameSrc,
                  const char * sFileNameDest,
                  void * pBuffer,
                  U32 NumBytes);
```

Parameters

Parameter	Description
<code>sFileNameSrc</code>	in Path to the file to be copied (0-terminated).
<code>sFileNameDest</code>	in Path to the copied file (0-terminated).
<code>pBuffer</code>	in Buffer for the copy operation (optional). Can be set to NULL.
<code>NumBytes</code>	Size of the copy buffer.

Return value

= 0 OK, file duplicated.
 ≠ 0 Error code indicating the failure reason.

Additional information

The source and destination files can be located on different volumes.

If no working buffer is specified the function uses a buffer of 512 bytes that is allocated on the stack.

Example

```
#include "FS.h"

void SampleBigFATCopy(void) {
    //
    // Copies the contents of "Test.txt" to file "TestCopy.txt" in the folder "SubDir".
    //
    FS_BIGFAT_Copy("Test.txt", "SubDir\\TestCopy.txt", NULL, 0);
}
```

16.4.4 FS_BIGFAT_FindClose()

Description

Ends a directory scanning operation.

Prototype

```
int FS_BIGFAT_FindClose(FS_BIGFAT_FIND_DATA * pFD);
```

Parameters

Parameter	Description
<code>pFD</code>	Context of the directory scanning operation.

Return value

= 0 OK, scan context closed.
< 0 Error code indicating the failure reason.

Additional information

`pFD` has to point to a structure that was successfully initialized via a call to `FS_BIGFAT_FindFirst()`.

Example

Refer to the sample usage of `FS_BIGFAT_FindFirst()`.

16.4.5 FS_BIGFAT_FindFirst()

Description

Initiates a directory scanning operation and returns information about the first file or directory.

Prototype

```
int FS_BIGFAT_FindFirst(    FS_BIGFAT_FIND_DATA * pFD,
                          const char      * sDirName,
                          char            * sFileName,
                          int             SizeOfFileName);
```

Parameters

Parameter	Description
<code>pFD</code>	Context of the directory scanning operation.
<code>sDirName</code>	Name of the directory to search in.
<code>sFileName</code>	Buffer that receives the name of the file found.
<code>SizeOfFileName</code>	Size in bytes of the <code>sFileName</code> buffer.

Return value

- = 1 OK, no files or directories available in directory.
- = 0 OK, information about the file or directory returned.
- < 0 Error code indicating the failure reason.

Additional information

The name of a visited file is truncated if it does not fit into `sFileName` buffer.

Example

```
#include <stdio.h>
#include <string.h>
#include "FS.h"

void SampleBigFATFind(void) {
    FS_BIGFAT_FIND_DATA FindData;
    int r;
    char acFileName[32];
    char ac[100];

    //
    // Lists the names of all files and directories located in the root directory
    // of the default volume.
    //
    memset(acFileName, 0, sizeof(acFileName));
    r = FS_BIGFAT_FindFirst(&FindData, "", acFileName, sizeof(acFileName));
    if (r < 0) {
        SEGGER_sprintf(ac, sizeof(ac), "Cannot list directory (%s)\n", FS_ErrorNo2Text(r));
        FS_X_Log(ac);
    } else {
        if (r == 1) {
            FS_X_Log("Empty directory\n");
        } else {
            for (;;) {
                SEGGER_sprintf(ac, sizeof(ac), "%s\n", acFileName);
                FS_X_Log(ac);
                r = FS_BIGFAT_FindNext(&FindData);
                if (r < 0) {
                    SEGGER_sprintf(ac, sizeof(ac), "Cannot list directory
(%s)\n", FS_ErrorNo2Text(r));
                    FS_X_Log(ac);
                    break;
                } else {
```

```
        if (r == 1) {  
            break;           // No more files or directories available.  
        }  
    }  
}  
}  
}  
FS_BIGFAT_FindClose(&FindData);  
}
```

16.4.6 FS_BIGFAT_FindNext()

Description

Returns information about the next file or directory in a directory scanning operation.

Prototype

```
int FS_BIGFAT_FindNext(FS_BIGFAT_FIND_DATA * pFD);
```

Parameters

Parameter	Description
<code>pFD</code>	Context of the directory scanning operation.

Return value

- = 1 OK, no files or directories available in directory.
- = 0 OK, information about the file or directory returned.
- < 0 Error code indicating the failure reason.

Additional information

`pFD` has to point to a structure that was successfully initialized via a call to `FS_BIGFAT_FindFirst()`.

Example

Refer to the sample usage of `FS_BIGFAT_FindFirst()`.

16.4.7 FS_BIGFAT_GetInfo()

Description

Returns information about a big file.

Prototype

```
int FS_BIGFAT_GetInfo(const char          * sFileName,
                     FS_BIGFAT_INFO * pInfo);
```

Parameters

Parameter	Description
sFileName	in Path to the file (0-terminated)
pInfo	out Information about the big file.

Return value

= 0 OK, information returned.
 ≠ 0 Error code indicating the failure reason.

Additional information

FS_BIGFAT_GetTime() can be called instead of FS_BIGFAT_GetInfo() to get the timestamp of a big file.

Example

```
#include <stdio.h>
#include <string.h>
#include "FS.h"

void SampleBigFATGetInfo(void) {
    FS_BIGFAT_INFO FileInfo;
    int r;
    FS_FILETIME    FileTime;
    char           ac[100];

    //
    // Gets information about a file and shows them.
    //
    memset(&FileInfo, 0, sizeof(FileInfo));
    r = FS_BIGFAT_GetInfo("Test.txt", &FileInfo);
    if (r == 0) {
        SEGGER_sprintf(ac, sizeof(ac), "Size:           %llu bytes\n", FileInfo.FileSize);
        FS_X_Log(ac);
        SEGGER_sprintf(ac, sizeof(ac), "Attributes:    0x%02X\n", FileInfo.Attributes);
        FS_X_Log(ac);
        FS_TimeStampToFileTime(FileInfo.CreationTime, &FileTime);
        SEGGER_sprintf(ac, sizeof(ac), "Creation time: %d-%.2d-%.2d %.2d:%.2d:%.2d",
            FileTime.Year, FileTime.Month, FileTime.Day,
            FileTime.Hour, FileTime.Minute, FileTime.Second);
        FS_X_Log(ac);
        FS_TimeStampToFileTime(FileInfo.LastAccessTime, &FileTime);
        SEGGER_sprintf(ac, sizeof(ac), "Access time:   %d-%.2d-%.2d %.2d:%.2d:%.2d",
            FileTime.Year, FileTime.Month, FileTime.Day,
            FileTime.Hour, FileTime.Minute, FileTime.Second);
        FS_X_Log(ac);
        FS_TimeStampToFileTime(FileInfo.LastWriteTime, &FileTime);
        SEGGER_sprintf(ac, sizeof(ac), "Write time:    %d-%.2d-%.2d %.2d:%.2d:%.2d",
            FileTime.Year, FileTime.Month, FileTime.Day,
            FileTime.Hour, FileTime.Minute, FileTime.Second);
        FS_X_Log(ac);
    }
}
```

16.4.8 FS_BIGFAT_GetPos()

Description

Returns the read and write position in the big file.

Prototype

```
int FS_BIGFAT_GetPos(FS_BIGFAT_FILE * pBigFile,
                    U64             * pPos);
```

Parameters

Parameter	Description
<code>pBigFile</code>	File handle that identifies the opened file.
<code>pPos</code>	out Position in the file as byte offset (0-based).

Return value

= 0 OK, file position returned.
 ≠ 0 Error code indicating the failure reason.

Additional information

The current file position can be modified by using `FS_BIGFAT_SetPos()` and is increased after each read or write operation by the number of bytes accessed.

`pBigFile` has to point to a structure that was successfully initialized via a call to `FS_BIFILE_Open()`.

Example

```
#include <stdio.h>
#include "FS.h"

void SampleBigFATGetPos(void) {
    FS_BIGFAT_FILE BigFile;
    U64             FilePos;
    int             r;
    char            ac[100];

    //
    // Opens a file for writing, writes some data to it and queries the file position.
    //
    r = FS_BIGFAT_Open(&BigFile, "Test.txt",
                      FS_BIGFAT_OPEN_FLAG_WRITE | FS_BIGFAT_OPEN_FLAG_CREATE);
    if (r == 0) {
        FS_BIGFAT_GetPos(&BigFile, &FilePos);
        SEGGER_sprintf(ac, sizeof(ac), "File position before write: %llu\n", FilePos);
        FS_X_Log(ac);
        FS_BIGFAT_Write(&BigFile, "Test", 4, NULL);
        FS_BIGFAT_GetPos(&BigFile, &FilePos);
        SEGGER_sprintf(ac, sizeof(ac), "File position after write: %llu\n", FilePos);
        FS_X_Log(ac);
        FS_BIGFAT_Close(&BigFile);
    }
}
```

16.4.9 FS_BIGFAT_GetSize()

Description

Returns the size of the big file.

Prototype

```
int FS_BIGFAT_GetSize(FS_BIGFAT_FILE * pBigFile,
                     U64 * pSize);
```

Parameters

Parameter	Description
<code>pBigFile</code>	File handle that identifies the opened file.
<code>pSize</code>	out Size of the file in bytes.

Return value

= 0 OK, file size returned.
 ≠ 0 Error code indicating the failure reason.

Additional information

`pBigFile` has to point to a structure that was successfully initialized via a call to `FS_BIFILE_Open()`.

Example

```
#include <stdio.h>
#include "FS.h"

void SampleBigFATGetSize(void) {
    FS_BIGFAT_FILE BigFile;
    U64      FileSize;
    int      r;
    char     ac[100];

    //
    // Opens a file for writing, writes some data to it and queries the file size.
    //
    r = FS_BIGFAT_Open(&BigFile, "Test.txt",
                      FS_BIGFAT_OPEN_FLAG_WRITE | FS_BIGFAT_OPEN_FLAG_CREATE);

    if (r == 0) {
        FS_BIGFAT_Write(&BigFile, "Test", 4, NULL);
        FS_BIGFAT_GetSize(&BigFile, &FileSize);
        SEGGER_sprintf(ac, sizeof(ac), "File size: %llu\n", FileSize);
        FS_X_Log(ac);
        FS_BIGFAT_Close(&BigFile);
    }
}
```

16.4.10 FS_BIGFAT_GetTime()

Description

Gets the timestamp of a big file.

Prototype

```
int FS_BIGFAT_GetTime(const char * sFileName,
                     U32 * pTimeStamp,
                     int TimeType);
```

Parameters

Parameter	Description
<code>sFileName</code>	in Partially-qualified path to the file to be queried (0-terminated)
<code>pTimeStamp</code>	out Read timestamp value.
<code>TimeType</code>	Type of timestamp to return. It can take one of the following values: <ul style="list-style-type: none"> • FS_FILETIME_CREATE • FS_FILETIME_ACCESS • FS_FILETIME_MODIFY

Return value

= 0 OK, timestamp returned.
≠ 0 Error code indicating the failure reason.

Additional information

Refer to `FS_GetFileTime()` for a description of the timestamp format. `FS_TimeStampToFileTime()` can be used to convert the timestamp to a `FS_FILETIME` structure that can be used to easily process the time information.

Example

```
#include "FS.h"

void SampleBigFATGetTime(void) {
    U32 TimeStamp;
    FS_FILETIME FileTime;
    char ac[100];
    int r;

    //
    // Gets the last modification time of a big file.
    //
    r = FS_BIGFAT_GetTime("Test.txt", &TimeStamp, FS_FILETIME_MODIFY);
    if (r == 0) {
        FS_TimeStampToFileTime(TimeStamp, &FileTime);
        SEGGER_sprintf(ac, sizeof(ac), "Access time: %d-%.2d-%.2d %.2d:%.2d:%.2d",
            FileTime.Year, FileTime.Month, FileTime.Day,
            FileTime.Hour, FileTime.Minute, FileTime.Second);
        FS_X_Log(ac);
    }
}
```

16.4.11 FS_BIGFAT_ModifyAttr()

Description

Modifies file attributes.

Prototype

```
int FS_BIGFAT_ModifyAttr(const char * sFileName,
                        unsigned SetMask,
                        unsigned ClrMask);
```

Parameters

Parameter	Description
<code>sFileName</code>	in Path to the file (0-terminated)
<code>SetMask</code>	Attributes that have to be set.
<code>ClrMask</code>	Attributes that have to be cleared.

Return value

= 0 OK, attributes modified.
 ≠ 0 Error code indicating the failure reason.

Additional information

The value passed to `SetMask` and `ClrMask` is an bitwise-or combination of *File attributes* on page 141. The `FS_ATTR_DIRECTORY` attribute cannot be set or cleared. The function does not report any error if the application attempts to do this.

Example

```
#include "FS.h"

void SampleBigFATModifyAttr(void) {
    //
    // Clears the ARCHIVE attribute and sets the SYSTEM and HIDDEN attributes
    // of the file "Test.txt".
    //
    FS_BIGFAT_ModifyAttr("Test.txt", FS_ATTR_SYSTEM | FS_ATTR_HIDDEN, FS_ATTR_ARCHIVE);
}
```

16.4.12 FS_BIGFAT_Move()

Description

Changes the location and the name of a big file.

Prototype

```
int FS_BIGFAT_Move(const char * sFileNameSrc,
                  const char * sFileNameDest);
```

Parameters

Parameter	Description
<code>sFileNameSrc</code>	in Path to the actual file (0-terminated)
<code>sFileNameDest</code>	in Path to the new file (0-terminated)

Return value

= 0 OK, file moved.
≠ 0 Error code indicating the failure reason.

Additional information

The source and destination paths can be located on different volumes.

A file can be renamed by calling `FS_BIGFAT_Move()` with `sFileNameDest` set to the same parent directory in `sFileNameDest` with the new file name added to it.

Example

```
#include "FS.h"

void SampleBigFATMove(void) {
    //
    // Moves the contents of "Test.txt" to file "TestCopy.txt" in the folder "SubDir".
    //
    FS_BIGFAT_Move("Test.txt", "SubDir\\TestCopy.txt");
}
```

16.4.13 FS_BIGFAT_Open()

Description

Opens a big file.

Prototype

```
int FS_BIGFAT_Open(      FS_BIGFAT_FILE * pBigFile,
                        const char      * sFileName,
                        unsigned        Flags);
```

Parameters

Parameter	Description
<code>pBigFile</code>	File handle that identifies the opened file.
<code>sFileName</code>	in Path to the file to be opened (0-terminated character string).
<code>Flags</code>	Specifies how the file has to be accessed.

Return value

= 0 OK, file opened.
 ≠ 0 Error code indicating the failure reason.

Additional information

The application has to call this function once for each file it wants to access. `FS_BIGFAT_Open()` creates or opens the base file according to `Flags` and initializes `pBigFile`. The application has to allocate `pBigFile` and to make sure that it stays valid until `FS_BIGFAT_Close()` is called. `pBigFile` identifies the opened file within the application and is passed as parameter to all the other API functions that access the file.

`FS_BIGFAT_Open()` makes a copy of `sFileName` that is then stored in `pBigFile`. Therefore, the application can release the memory allocated to `sFileName` after `FS_BIGFAT_Open()` returns.

`Flags` is a bitwise OR combination of *File open flags* on page 1385. Permitted combinations are:

Flag combination	Description
<code>FS_BIGFAT_OPEN_FLAG_READ</code>	Open an existing file for reading
<code>FS_BIGFAT_OPEN_FLAG_WRITE</code> <code>FS_BIGFAT_OPEN_FLAG_CREATE</code>	Create a new file or truncate an existing one for writing
<code>FS_BIGFAT_OPEN_FLAG_WRITE</code> <code>FS_BIGFAT_OPEN_FLAG_APPEND</code> <code>FS_BIGFAT_OPEN_FLAG_CREATE</code>	Create a new file or append to an existing one for writing
<code>FS_BIGFAT_OPEN_FLAG_READ</code> <code>FS_BIGFAT_OPEN_FLAG_WRITE</code>	Open an existing file for reading and writing
<code>FS_BIGFAT_OPEN_FLAG_READ</code> <code>FS_BIGFAT_OPEN_FLAG_WRITE</code>	Create a new file or truncate an existing one for reading and writing

Flag combination	Description
FAT_OPEN_FLAG_WRITE FS_BIG- FAT_OPEN_FLAG_CREATE	
FS_BIG- FAT_OPEN_FLAG_READ FS_BIG- FAT_OPEN_FLAG_WRITE FS_BIG- FAT_OPEN_FLAG_AP- PEND FS_BIG- FAT_OPEN_FLAG_CREATE	Create a new file or append to an existing one for reading and writing

Example

The next example demonstrates how to open a file for reading.

```
#include "FS.h"

void SampleBigFATOpenRead(void) {
    FS_BIGFAT_FILE BigFile;
    int r;

    //
    // Opens a file for reading on the root directory of the default volume.
    // The file has to exist before opening it.
    //
    r = FS_BIGFAT_Open(&BigFile, "Test.txt", FS_BIGFAT_OPEN_FLAG_READ);
    if (r == 0) {

        //
        // Perform read accesses to file
        //

        FS_BIGFAT_Close(&BigFile);
    }
}
```

This example demonstrates how to open a file for writing.

```
#include "FS.h"

void SampleBigFATOpenWrite(void) {
    FS_BIGFAT_FILE BigFile;
    int r;

    //
    // Opens a file for writing on the root directory of the default volume.
    // The file has to exist before opening it.
    //
    r = FS_BIGFAT_Open(&BigFile, "Test.txt", FS_BIGFAT_OPEN_FLAG_WRITE);
    if (r == 0) {

        //
        // Perform write accesses to file.
        //

        FS_BIGFAT_Close(&BigFile);
    }
}
```

This example demonstrates how to open a file for reading and writing.

```
#include "FS.h"

void SampleBigFATOpenReadWrite(void) {
    FS_BIGFAT_FILE BigFile;
    int r;
```

```

//
// Opens a file for reading and writing on the root directory of the "nand:0:" volume.
// The file has to exist before opening it.
//
r = FS_BIGFAT_Open(&BigFile, "nand:0:\\Test.txt",
                  FS_BIGFAT_OPEN_FLAG_READ | FS_BIGFAT_OPEN_FLAG_WRITE);
if (r == 0) {

    //
    // Perform read and write accesses to file
    //

    FS_BIGFAT_Close(&BigFile);
}
}

```

This example demonstrates how to create a file.

```

#include <stdio.h>
#include "FS.h"

void SampleBigFATOpenWriteCreate(void) {
    FS_BIGFAT_FILE BigFile;
    int r;

    //
    // Opens a file for writing on the folder "SubDir" of the default volume.
    // The directory delimiter is the '\' character. If the file does
    // not exist it is created. If the file exists it is truncated to 0.
    //
    r = FS_BIGFAT_Open(&BigFile, "\\SubDir\\Test.txt",
                      FS_BIGFAT_OPEN_FLAG_WRITE | FS_BIGFAT_OPEN_FLAG_CREATE);
    if (r == 0) {

        //
        // Perform write accesses to file.
        //

        FS_BIGFAT_Close(&BigFile);
    }
}

```

The next example demonstrates how open a file for writing at the end of it.

```

#include "FS.h"

void SampleBigFATOpenAppend(void) {
    FS_BIGFAT_FILE BigFile;
    int r;

    //
    // Opens a file for writing at the end on the root directory of the default volume.
    // The file has to exist before opening it.
    //
    r = FS_BIGFAT_Open(&BigFile, "Test.txt",
                      FS_BIGFAT_OPEN_FLAG_WRITE | FS_BIGFAT_OPEN_FLAG_APPEND);
    if (r == 0) {

        //
        // Perform write accesses to file.
        //

        FS_BIGFAT_Close(&BigFile);
    }
}

```

16.4.14 FS_BIGFAT_Read()

Description

Reads data from the big file.

Prototype

```
int FS_BIGFAT_Read(FS_BIGFAT_FILE * pBigFile,
                  void * pData,
                  U32 NumBytesToRead,
                  U32 * pNumBytesRead);
```

Parameters

Parameter	Description
<code>pBigFile</code>	File handle that identifies the opened big file. It cannot be set to <code>NULL</code> .
<code>pData</code>	out Data read from big file.
<code>NumBytesToRead</code>	Number of bytes requested to be read from the big file.
<code>pNumBytesRead</code>	out Number of bytes actually read from the big file. It can be set to <code>NULL</code> .

Return value

= 0 OK, data read from file.
 ≠ 0 Error code indicating the failure reason.

Additional information

The data is read from the current position in the file that is stored in the file handle. The current file position is set to first byte in the file (that is 0) when the file is opened. The file position is advanced by the number of bytes actually read from file.

If either `pData` is set to `NULL` or `NumBytesToRead` is set to 0 success is returned but no data is read. `*pNumBytesRead` is set to 0 in this case.

`pBigFile` has to point to a structure that was successfully initialized via a call to `FS_BIFILE_Open()`.

Example

```
#include "FS.h"

void SampleBigFATRead(void) {
    FS_BIGFAT_FILE BigFile;
    int r;
    U8 abData[4];

    //
    // Opens a file for reading on the root directory of the default volume.
    //
    r = FS_BIGFAT_Open(&BigFile, "Test.txt", FS_BIGFAT_OPEN_FLAG_READ);
    if (r == 0) {
        //
        // Read some data from the beginning of the opened file
        //
        FS_BIGFAT_Read(&BigFile, abData, sizeof(abData), NULL);
        //
        // Close the file.
        //
        FS_BIGFAT_Close(&BigFile);
    }
}
```

16.4.15 FS_BIGFAT_Remove()

Description

Deletes a big file.

Prototype

```
int FS_BIGFAT_Remove(const char * sFileName);
```

Parameters

Parameter	Description
sFileName	in Path to the file to be removed (0-terminated)

Return value

= 0 OK, file removed.
≠ 0 Error code indicating the failure reason.

Additional information

The contents of the big file is lost after calling this function.

Example

```
#include "FS.h"

void SampleBigFATRemove(void) {
    //
    // Deletes the file "Test.txt" located in the folder "SubDir".
    //
    FS_BIGFAT_Remove("SubDir\\Test.txt");
}
```

16.4.16 FS_BIGFAT_SetPos()

Description

Changes the access position in the big file.

Prototype

```
int FS_BIGFAT_SetPos(FS_BIGFAT_FILE * pBigFile,
                    U64                Pos);
```

Parameters

Parameter	Description
<code>pBigFile</code>	File handle that identifies the opened file.
<code>Pos</code>	Position in the file as byte offset (0-based).

Return value

= 0 OK, file position changed.
 ≠ 0 Error code indicating the failure reason.

Additional information

The current file position can be queried using `FS_BIGFAT_SetPos()`.

`pBigFile` has to point to a structure that was successfully initialized via a call to `FS_BIFILE_Open()`.

Example

```
#include "FS.h"

void SampleBigFATSetPos(void) {
    FS_BIGFAT_FILE BigFile;
    U64             FilePos;
    int             r;

    //
    // Opens a file for writing, writes some data to it and then overwrites it.
    //
    r = FS_BIGFAT_Open(&BigFile, "Test.txt",
                      FS_BIGFAT_OPEN_FLAG_WRITE | FS_BIGFAT_OPEN_FLAG_CREATE);

    if (r == 0) {
        FS_BIGFAT_Write(&BigFile, "Test", 4, NULL);
        FS_BIGFAT_SetPos(&BigFile, 0);
        FS_BIGFAT_Write(&BigFile, "Done", 4, NULL);
        FS_BIGFAT_Close(&BigFile);
    }
}
```

16.4.17 FS_BIGFAT_SetSize()

Description

Increases or reduces the size of a big file.

Prototype

```
int FS_BIGFAT_SetSize(FS_BIGFAT_FILE * pBigFile,
                     U64                Size);
```

Parameters

Parameter	Description
<code>pBigFile</code>	File handle that identifies the opened file.
<code>Size</code>	New file size.

Return value

= 0 OK, file size changed.
 ≠ 0 Error code indicating the failure reason.

Additional information

If the file is extended then the additional bytes contain uninitialized data. In addition, the position in the file is not modified.

`pBigFile` has to point to a structure that was successfully initialized via a call to `FS_BIFILE_Open()`.

Example

```
#include "FS.h"

void SampleBigFATSetSize(void) {
    FS_BIGFAT_FILE BigFile;
    int            r;

    //
    // Opens a file for writing and sets it size to 100 Kbytes.
    //
    r = FS_BIGFAT_Open(&BigFile, "Test.txt",
                      FS_BIGFAT_OPEN_FLAG_WRITE | FS_BIGFAT_OPEN_FLAG_CREATE);

    if (r == 0) {
        FS_BIGFAT_SetSize(&BigFile, 100 * 1024);
        FS_BIGFAT_Close(&BigFile);
    }
}
```

16.4.18 FS_BIGFAT_SetTime()

Description

Sets the timestamp of a big file.

Prototype

```
int FS_BIGFAT_SetTime(const char * sFileName,
                    U32      TimeStamp,
                    int      TimeType);
```

Parameters

Parameter	Description
<code>sFileName</code>	in Partially-qualified path to the file to be queried (0-terminated)
<code>TimeStamp</code>	The value of the timestamp to be set.
<code>TimeType</code>	Type of timestamp to be modified. It can take of the following values: <ul style="list-style-type: none"> • FS_FILETIME_CREATE • FS_FILETIME_ACCESS • FS_FILETIME_MODIFY

Return value

= 0 OK, timestamp modified.
≠ 0 Error code indicating the failure reason.

Additional information

Refer to `FS_GetFileTime()` for a description of the timestamp format. `FS_FileTimeToTimeStamp()` can be used to convert a `FS_FILETIME` structure to a timestamp that can be used in a call to `FS_SetFileTimeEx()`.

This function is optional because the file system automatically updates the timestamps of a big file as required.

Example

```
#include "FS.h"

void SampleBigFATSetTime(void) {
    U32      TimeStamp;
    FS_FILETIME FileTime;

    //
    // Modifies the creation time of a big file.
    //
    FileTime.Year   = 2022;
    FileTime.Month  = 12;
    FileTime.Day    = 22;
    FileTime.Hour   = 8;
    FileTime.Minute = 2;
    FileTime.Second = 48;
    FS_FileTimeToTimeStamp(&FileTime, &TimeStamp);
    FS_BIGFAT_SetTime("Test.txt", TimeStamp, FS_FILETIME_CREATE);
}
```

16.4.19 FS_BIGFAT_Sync()

Description

Saves cached information to storage device.

Prototype

```
int FS_BIGFAT_Sync(FS_BIGFAT_FILE * pBigFile);
```

Parameters

Parameter	Description
pBigFile	File handle that identifies the opened file.

Return value

= 0 OK, file synchronized.
 ≠ 0 Error code indicating the failure reason.

Additional information

pBigFile has to point to a structure that was successfully initialized via a call to FS_BIFILE_Open().

Example

```
#include <stdio.h>
#include "FS.h"

void SampleBigFATSync(void) {
    FS_BIGFAT_FILE BigFile;
    int r;

    //
    // Opens a file for writing, writes some data to it while making sure that
    // the data is written to storage.
    //
    r = FS_BIGFAT_Open(&BigFile, "Test.txt",
                      FS_BIGFAT_OPEN_FLAG_WRITE | FS_BIGFAT_OPEN_FLAG_CREATE);

    if (r == 0) {
        FS_BIGFAT_Write(&BigFile, "Test1", 5, NULL);
        FS_BIGFAT_Sync(&BigFile);
        FS_BIGFAT_Write(&BigFile, "Test2", 5, NULL);
        FS_BIGFAT_Close(&BigFile);
    }
}
```

16.4.20 FS_BIGFAT_Write()

Description

Writes data to the big file.

Prototype

```
int FS_BIGFAT_Write(      FS_BIGFAT_FILE * pBigFile,
                        const void      * pData,
                        U32              NumBytesToWrite,
                        U32              * pNumBytesWritten);
```

Parameters

Parameter	Description
<code>pBigFile</code>	File handle that identifies the opened big file.
<code>pData</code>	in Data to be written to big file.
<code>NumBytesToWrite</code>	Number of bytes requested to be written to the big file.
<code>pNumBytesWritten</code>	out Number of bytes actually written to the big file. Can be NULL.

Return value

= 0 OK, data written to file.
 ≠ 0 Error code indicating the failure reason.

Additional information

The data is written at the current position in the file that is stored in the file handle. The current file position is set to first byte in the file (that is 0) when the file is opened. The file position is advanced by the number of bytes actually written to file.

`pBigFile` has to point to a structure that was successfully initialized via a call to `FS_BIFILE_Open()`.

Example

```
#include "FS.h"

void SampleBigFATWrite(void) {
    FS_BIGFAT_FILE BigFile;
    int             r;

    //
    // Opens a file for writing on the root directory of the default volume.
    // The file has to exist before opening it.
    //
    r = FS_BIGFAT_Open(&BigFile, "Test.txt", FS_BIGFAT_OPEN_FLAG_WRITE);
    if (r == 0) {
        //
        // Write some data to file.
        //
        FS_BIGFAT_Write(&BigFile, "Test", 4, NULL);
        FS_BIGFAT_Close(&BigFile);
    }
}
```

16.4.21 FS_BIGFAT_INFO

Description

Information about a big file.

Type definition

```
typedef struct {
    U8   Attributes;
    U32  CreationTime;
    U32  LastAccessTime;
    U32  LastWriteTime;
    U64  FileSize;
} FS_BIGFAT_INFO;
```

Structure members

Member	Description
Attributes	File or directory attributes.
CreationTime	Date and time when the file was created.
LastAccessTime	Date and time when the file was accessed last.
LastWriteTime	Date and time when the file was written to last.
FileSize	Size of the file in bytes.

Additional information

The [Attributes](#) member is a bitwise-or combination of the following flags: `FS_ATTR_READ_ONLY`, `FS_ATTR_HIDDEN`, `FS_ATTR_SYSTEM`, `FS_ATTR_ARCHIVE`, or `FS_ATTR_DIRECTORY`.

16.4.22 FS_BIGFAT_FIND_DATA

Description

Information about a file or directory.

Type definition

```
typedef struct {
    U8           Attributes;
    U32          CreationTime;
    U32          LastAccessTime;
    U32          LastWriteTime;
    U64          FileSize;
    char         * sFileName;
    U16          SizeOfFileName;
    FS_FIND_DATA FindData;
    FS_BIGFAT_FILE BigFile;
} FS_BIGFAT_FIND_DATA;
```

Structure members

Member	Description
Attributes	Attributes of the file or directory.
CreationTime	Date and time when the file or directory was created.
LastAccessTime	Date and time when the file or directory was accessed last.
LastWriteTime	Date and time when the file or directory was modified last.
FileSize	Size of the file in bytes.
sFileName	Name of the file or directory as 0-terminated string. It points to the buffer passed as argument to <code>FS_BIGFAT_FindFirst()</code> .
SizeOfFileName	Internal. Not to be used by the application.
FindData	Internal. Not to be used by the application.
BigFile	Internal. Not to be used by the application.

Additional information

This structure contains also the context for the file listing operation. These members are considered internal and should not be used by the application. `FS_BIGFAT_FIND_DATA` is used as context by the `FS_BIGFAT_FindFirst()` and `FS_BIGFAT_FindNext()` pair of functions.

16.4.23 File open flags

Description

Options to open a file.

Definition

```
#define FS_BIGFAT_OPEN_FLAG_READ      0x01u
#define FS_BIGFAT_OPEN_FLAG_WRITE    0x02u
#define FS_BIGFAT_OPEN_FLAG_CREATE   0x04u
#define FS_BIGFAT_OPEN_FLAG_APPEND   0x08u
```

Symbols

Definition	Description
FS_BIGFAT_OPEN_FLAG_READ	The application can read from the opened file.
FS_BIGFAT_OPEN_FLAG_WRITE	The application can write to the opened file.
FS_BIGFAT_OPEN_FLAG_CREATE	The file is created if it does not exist or it is truncated to 0 if it exists.
FS_BIGFAT_OPEN_FLAG_APPEND	The application can write only at the end of the file.

Additional information

These flags can be used as values for the Flags parameter of `FS_BIGFAT_Open()`. The flags are bitmasks that can be combined by a bitwise-or operator.

16.5 BigFAT converter utility

emFile comes with a convenient command line utility for PC that helps to convert between a regular host file and one or more fragment files that can be managed by a target application using the BigFAT component. The command line utility is able to merge the fragment files generated on a target device into a single file larger than 4 Gbytes. In addition, the command line utility is also able to split a file larger than 4 Gbytes into fragment files that can later be copied to a target device in order to be accessed by a target application.

16.5.1 Using the utility

The utility can be invoked directly from the command line or via a batch file. A terminal window must be opened first in order to use the utility interactively. First, the name of the executable (`BigFAT.exe`) has to be input on the command line followed by optional and required arguments. By pressing the Enter key the utility starts the merge or split operation as specified.

Below is a screen shot of the `BigFAT.exe` utility that is invoked to merge the contents of the file `TestFile1.bin` created on the target device.

The merged data replaces the contents of the original file. In case of an error a message is displayed indicating the failure reason and the utility returns with a status of 1. The original target file is left unmodified in this case.

```

Command Prompt
c:\SEGGGER>BigFAT.exe -d C:\SEGGGER\TestFile1.bin I:\TestFile1.bin
BigFAT V5.18.0 compiled Jul 25 2022 09:07:05
(c) 2010-2022 SEGGER Microcontroller GmbH      www.segger.com
Press '?' for help

Source file:      "I:\TestFile1.bin"
Destination file: "C:\SEGGGER\TestFile1.bin"
Merging.....
.....OK (1000000000 bytes)

c:\SEGGGER>

```

Merging operation

Assuming the original `TestFile1.bin` file is 6 Gbytes large then at the end of execution it is truncated to 4 Gbytes - 128 Kbytes. The remaining number of bytes is stored to a file named `TestFile1.bin.001.BigFAT`

16.5.2 Command line options

The following table lists the parameters which can be omitted when invoking the utilities.

Option	Description
-d	Specifies a destination file.
-h	Shows the usage message and exits.
-q	Suppresses log information.
-s	Performs a split operation.
-v	Shows version information and exits.

16.5.2.1 -d

Description

Specifies the name of a destination file. By default the source file is overwritten.

Syntax

-d <DestFile>

Example

The following example shows how to merge the contents of the file `TestFileTarget.bin` to the file `TestFileHost.bin`

```
C:>BigFAT.exe -d TestFileHost.bin TestFileTarget.bin
```

The following example shows how to split the contents of the file `TestFileHost.bin` to the file `TestFileTarget.bin`

```
C:>BigFAT.exe -s -d TestFileTarget.bin TestFileHost.bin
```

16.5.2.2 -h

Description

Shows the usage message and exits.

Syntax

-h

Example

```
C:>BigFAT.exe -h
BigFAT V5.18.0 compiled Jul 22 2022 15:32:43
(c) 2010-2020 SEGGER Microcontroller GmbH      www.segger.com
Press '?' for help

DESCRIPTION
  BigFAT merge/split utility for SEGGER emFile.
USAGE
  BigFAT [-d <DestFile>] [-h] [-q] [-s] [-v] <SrcFile>
OPTIONS
  -d <DestFile>  Path to merged/split file to be created.
                  Default is the name of the source file.
  -h             Show this help information.
  -q            Do not show log messages.
  -s            Split a big file. Default is merging.
  -v            Show version information.
ARGUMENTS
  <SrcFile>     Path to file to be merged/split.
```

16.5.2.3 -q

Description

Suppresses log information. By default all the log messages are shown in the terminal window.

Syntax

-q

16.5.2.4 -s

Description

Performs a split operation. By default a merge operation is performed.

Syntax

-s

Example

The following example demonstrates how to split the contents of the file `TestFile1.bin`. The original file is overwritten. The created fragment files can be copied to the target device.

```
C:>BigFAT.exe -s TestFile1.bin
```

16.5.2.5 -v

Description

Shows version information and exits.

Syntax

-v

Example

```
C:>BigFAT.exe -v
BigFAT V5.18.0 compiled Jul 22 2022 15:32:43
(c) 2010-2020 SEGGER Microcontroller GmbH      www.segger.com
Press '?' for help
```

16.5.3 Command line arguments

The following table lists the mandatory parameters.

Parameter	Description
<code>SrcFile</code>	Path to the file to be converted.

16.5.3.1 SrcFile

Description

Path to the file to be converted.

Additional information

In case of a merge operation `SrcFile` specifies the name of the first fragment file of a file created via the BigFAT component on a target storage device. If a split operation is executed then `SrcFile` specifies the name of the host file to be converted.

Example

The following example demonstrates how to merge the contents of the file `TestFile1.bin` generated on a target device via the BigFAT component.

```
C:>BigFAT.exe TestFile3.bin
```

Chapter 17

NAND Image Creator

This chapter provides information about the emFile utility that can be used to create file system images for NAND flash devices.

17.1 General information

The NAND Image Creator is a command line utility that can be used to create a file containing a one-to-one representation of the contents of a NAND flash device (image file) with preselected files and directories found on the host PC.

The NAND Image Creator provides commands for performing standard file system operations such as formatting the storage device low as well as high level, copying files and directories from the host PC to the image file or checking the consistency of the file system structure.

The generated image file is a regular binary file that can be programmed directly into the NAND flash device of the target system via a SEGGER production programmer (<https://www.segger.com/products/flash-in-circuit-programmers/>) or via any other third-party utility.

The NAND Image Creator ships with executables for Windows, Linux and macOS systems that can be used to create images for the FAT and EFS file systems.

17.2 Using the NAND Image Creator

The NAND Image Creator utility can be used like any other command line based program. For the ease of usage many commands are kept similar to their DOS counterparts. By entering "?" or just pressing the Enter key an overview of the commands is printed on the screen and it should look like the picture below.

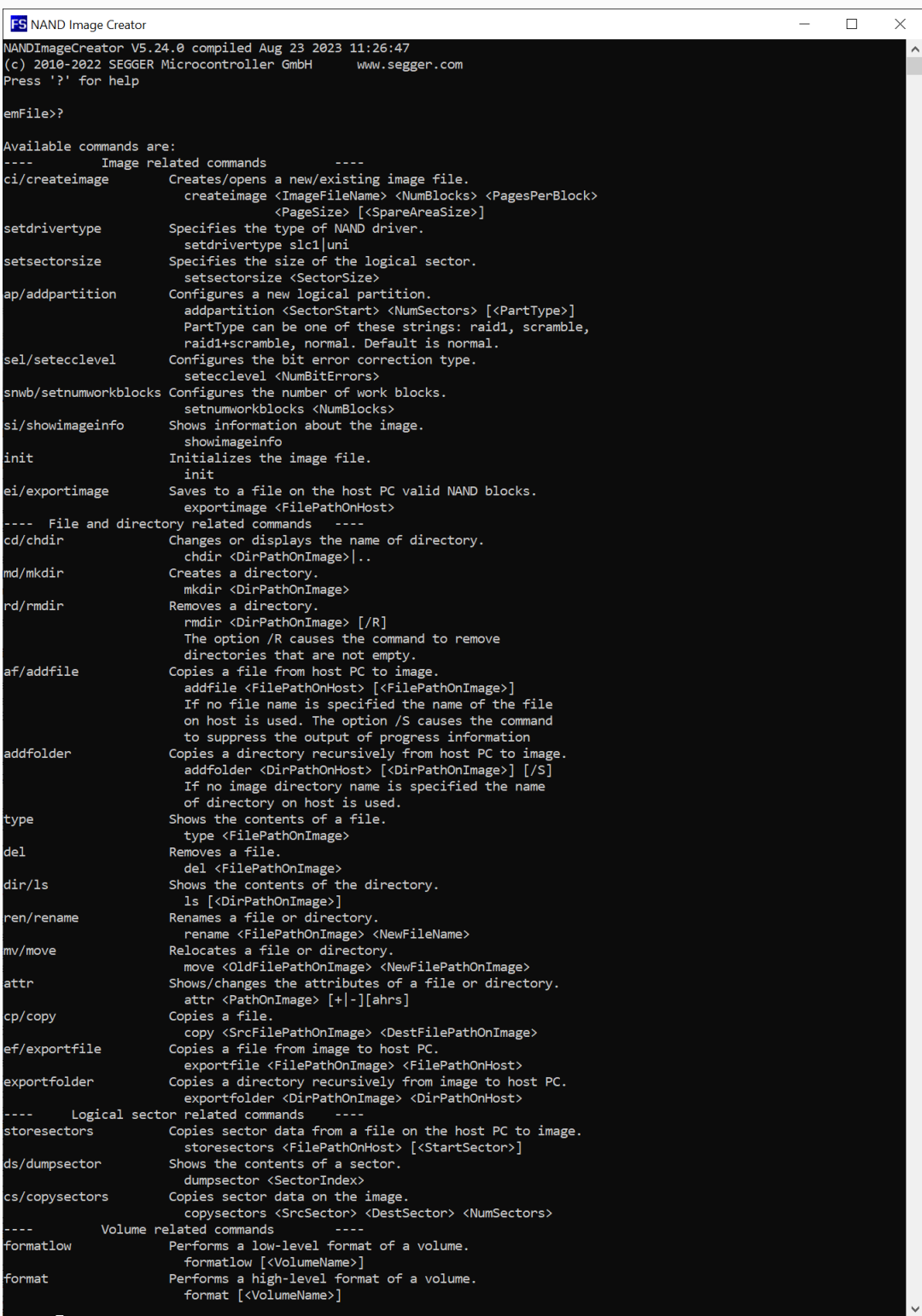

```

FS NAND Image Creator
NANDImageCreator V5.24.0 compiled Aug 23 2023 11:26:47
(c) 2010-2022 SEGGER Microcontroller GmbH www.segger.com
Press '?' for help

emFile)?

Available commands are:
---- Image related commands ----
ci/createimage      Creates/opens a new/existing image file.
                    createimage <ImageFileName> <NumBlocks> <PagesPerBlock>
                    <PageSize> [<SpareAreaSize>]
setdrvivertype      Specifies the type of NAND driver.
                    setdrvivertype slc1|uni
setsectorsize       Specifies the size of the logical sector.
                    setsectorsize <SectorSize>
ap/addpartition     Configures a new logical partition.
                    addpartition <SectorStart> <NumSectors> [<PartType>]
                    PartType can be one of these strings: raid1, scramble,
                    raid1+scramble, normal. Default is normal.
sel/setecclevel     Configures the bit error correction type.
                    setecclevel <NumBitErrors>
snwb/setnumworkblocks Configures the number of work blocks.
                    setnumworkblocks <NumBlocks>
si/showimageinfo    Shows information about the image.
                    showimageinfo
init               Initializes the image file.
                    init
ei/exportimage      Saves to a file on the host PC valid NAND blocks.
                    exportimage <FilePathOnHost>
---- File and directory related commands ----
cd/chdir           Changes or displays the name of directory.
                    chdir <DirPathOnImage>|..
md/mkdir          Creates a directory.
                    mkdir <DirPathOnImage>
rd/rmdir          Removes a directory.
                    rmdir <DirPathOnImage> [/R]
                    The option /R causes the command to remove
                    directories that are not empty.
af/addfile        Copies a file from host PC to image.
                    addfile <FilePathOnHost> [<FilePathOnImage>]
                    If no file name is specified the name of the file
                    on host is used. The option /S causes the command
                    to suppress the output of progress information
addfolder         Copies a directory recursively from host PC to image.
                    addfolder <DirPathOnHost> [<DirPathOnImage>] [/S]
                    If no image directory name is specified the name
                    of directory on host is used.
type             Shows the contents of a file.
                    type <FilePathOnImage>
del             Removes a file.
                    del <FilePathOnImage>
dir/ls          Shows the contents of the directory.
                    ls [<DirPathOnImage>]
ren/rename      Renames a file or directory.
                    rename <FilePathOnImage> <NewFileName>
mv/move        Relocates a file or directory.
                    move <OldFilePathOnImage> <NewFilePathOnImage>
attr          Shows/changes the attributes of a file or directory.
                    attr <PathOnImage> [+|-][ahrs]
cp/copy        Copies a file.
                    copy <SrcFilePathOnImage> <DestFilePathOnImage>
ef/exportfile   Copies a file from image to host PC.
                    exportfile <FilePathOnImage> <FilePathOnHost>
exportfolder    Copies a directory recursively from image to host PC.
                    exportfolder <DirPathOnImage> <DirPathOnHost>
---- Logical sector related commands ----
storesectors     Copies sector data from a file on the host PC to image.
                    storesectors <FilePathOnHost> [<StartSector>]
ds/dumpsector    Shows the contents of a sector.
                    dumpsector <SectorIndex>
cs/copysectors  Copies sector data on the image.
                    copysectors <SrcSector> <DestSector> <NumSectors>
---- Volume related commands ----
formatlow       Performs a low-level format of a volume.
                    formatlow [<VolumeName>]
format         Performs a high-level format of a volume.
                    format [<VolumeName>]

```

NAND Image Creator

The NAND Image Creator utility can work in two modes: interactive and script. The interactive mode is entered when the utility is started with no command line arguments. In this mode the user is prompted to type in the commands to be executed. The script mode is

entered when the utility is started with a command line argument that specifies the name of a file containing the commands to be executed, one command per line.

17.2.1 Sample script file

The following sample shows a simple script file which does the following:

- Creates a 128 Mbyte NAND flash image file `C:\flash.bin`
- Sets the type of NAND driver which will be used on the target to access the NAND flash device to Universal NAND driver. This command is optional since the default driver type.
- Creates the image file.
- Low-level formats the volume on the image file.
- High-level formats the volume on the image file.
- Copies the `Test.txt` file from drive `C:` of the host Windows PC to root directory of the volume stored on the image file.
- Copies recursively the contents of `Data` directory from host PC to `Data` directory of the volume stored on the image file.

```
createimage C:\flash.bin 1024 64 2048
setdrivertype uni
init
formatlow
format
addfile C:\Test.txt
addfolder C:\Data\
q
```

17.3 Supported commands

The image file can be processed by using build it commands of the NAND Image Creator utility. The table below lists all the available commands followed by a detailed description. The optional command parameters are enclosed in square brackets in the syntax description of a command.

Command	Description
Image related commands	
<code>createimage</code>	Creates/opens a new/existing image file.
<code>setdrvtype</code>	Configures the NAND driver type.
<code>setsectorsize</code>	Configures the logical sector size.
<code>addpartition</code>	Configures a logical partition.
<code>setecclevel</code>	Configures the error correction type.
<code>setnumworkblocks</code>	Configures the number of work blocks.
<code>showimageinfo</code>	Shows information about the image file.
<code>init</code>	Initializes the image file.
<code>exportimage</code>	Saves to a file the NAND blocks that contain valid data.
File and directory related commands	
<code>cd</code>	Changes the current working directory.
<code>md</code>	Creates a directory.
<code>rd</code>	Removes a directory.
<code>addfile</code>	Copies a file from the host PC to the image file.
<code>addfolder</code>	Copies a folder including its subfolders and files from the host PC to the image file.
<code>type</code>	Shows the contents of a file.
<code>del</code>	Deletes a file.
<code>dir</code>	Lists the contents of the directory.
<code>ren</code>	Renames a file or directory.
<code>move</code>	Moves a file or directory to another location.
<code>attr</code>	Shows/changes the file/directory attributes.
<code>copy</code>	Copies a file to another location.
<code>exportfile</code>	Copies a file from image file to host PC.
<code>exportfolder</code>	Copies a directory recursively from image to host PC.
Logical sector related commands	
<code>storesectors</code>	Copies logical sector data from a file on the PC host to image file.
<code>dumpsector</code>	Shows the contents of a logical sector.
<code>copysectors</code>	Copies logical sector data to another location.
Volume related commands	
<code>formatlow</code>	Low-level formats a volume.
<code>format</code>	High-level formats a volume.
<code>df</code>	Shows the available free space on a volume.
<code>diskinfo</code>	Shows information about a volume.
<code>getdevinfo</code>	Shows information about a storage device.
<code>checkdisk</code>	Checks a volume for errors.
<code>creatembr</code>	Writes partition table to master boot record (MBR).

Command	Description
<code>listvolumes</code>	Shows the names of all available volumes.

17.3.1 Image related commands

The following sections describe the commands required to create an image file.

17.3.1.1 createimage

Description

Creates/opens a new/existing image file.

Syntax

```
createimage <ImageFileName> <NumBlocks> <PagesPerBlock> <PageSize>
[<SpareAreaSize>]
ci          <ImageFileName> <NumBlocks> <PagesPerBlock> <PageSize>
           [<SpareAreaSize>]
```

Parameters

Parameter	Description
ImageFileName	Name of the image file to be created/opened.
NumBlocks	Number of NAND blocks.
PagesPerBlock	Number of pages in a NAND block.
PageSize	Number of bytes in a NAND page excluding the spare area.
SpareAreaSize	Number of bytes in the spare area of a NAND page.

Additional information

This command is mandatory and it must be the first command to be executed.

The size of the image file is $\text{NumBlocks} * \text{PagesPerBlock} * (\text{PageSize} + \text{SpareAreaSize})$ bytes large. The image file is silently overwritten if the image file already exists but the calculated size of the file does not match. If [SpareAreaSize](#) is not specified then the utility calculates it as 1/32 of [PageSize](#).

[PageSize](#) has to be a power of 2 value. The values for [PagesPerBlock](#), [PageSize](#) and [SpareAreaSize](#) have to match the values of the NAND flash device the file image will be stored to otherwise the application will not be able to access the data via emFile. [NumBlocks](#) has to match either the maximum number of blocks in the NAND flash device or the number of blocks specified as the second parameter in the call to `FS_NAND_SetBlockRange()` or `FS_NAND_UNI_SetBlockRange()`.

Example

The example shows how to create 128 Mbytes image file.

```
createimage C:\nand.bin 1024 64 2048
```

17.3.1.2 setdrivertype

Description

Configures the NAND driver type.

Syntax

```
setdrivertype <DriverType>
```

Parameters

Parameter	Description
<code>DriverType</code>	The type of NAND driver used to access the files on the target. <ul style="list-style-type: none"><code>slc1</code> - SLC1 NAND driver<code>uni</code> - Universal NAND driver

Additional information

This command is optional. If not executed an image file is created that can be accessed on the target using the Universal NAND driver.

Example

The examples shows how to specify that the SLC1 NAND driver is used on the target to access the NAND flash.

```
setdrivertype slc1
```

17.3.1.3 setsectorsize

Description

Configures the logical sector size.

Syntax

```
setsectorsize <SectorSize>
```

Parameters

Parameter	Description
<code>SectorSize</code>	The size of the logical sector in bytes.

Additional information

This command is optional. It can be used to set the size of the logical sector when the SLC1 NAND driver type is selected. Any power of 2 value between 512 bytes and the number of bytes in a NAND page can be used. When this command is not executed the size of the logical sector is set automatically to the configured page size of NAND flash device. The size of the logical sector as to be smaller than or equal to the size of the logical sector configured on the target application via `FS_SetMaxSectorSize()`.

Example

This example shows how to set the logical sector size to 512 bytes.

```
setsectorsize 512
```

17.3.1.4 addpartition

Description

Configures a logical partition.

Syntax

```
addpartition <StartSector> <NumSectors> [<PartType>]
ap          <StartSector> <NumSectors> [<PartType>]
```

Parameters

Parameter	Description
<code>StartSector</code>	Index of the first sector in the partition.
<code>NumSectors</code>	Number of sectors in the partition.
<code>PartType</code>	Type of the partition to create. Permitted values are: <ul style="list-style-type: none"> <code>normal</code> - The entire partition space is used by the file system as storage (default). <code>raid1</code> - The file system can use only half of the partition space as storage. The other half is used as mirror partition.

Additional information

This command is optional. It allows the creation of logical partitions on the image file. The command fails if the defined sector range overlaps the range of an already defined logical partition. A maximum of four logical partitions can be created. The partition list has to be stored to image after initialization of the image using the `createmb` command. The data on the created logical partitions can be accessed using the Disk Partition driver. The logical partitions can be formatted using the `format` command. The value of `StartSector` is relative to the beginning of the storage device.

Example

This example shows how to configure 2 logical partitions. The sector 0 is reserved for Master Boot Record where the partition list is stored.

```
addpartition 1 10000
addpartition 10001 20000
```

A possible emFile configuration that allows the application to access the logical partitions looks like this:

```
#include <FS.h>
#include "FS_NAND_HW_Template.h"

#define ALLOC_SIZE      0x9000          // Memory pool for the file system in bytes

static U32 _aMemBlock[ALLOC_SIZE / 4]; // Memory pool used for semi-dynamic allocation.

void FS_X_AddDevices(void) {
    FS_AssignMemory(&_aMemBlock[0], sizeof(_aMemBlock));
    FS_SetMaxSectorSize(2048);
    //
    // Add and configure the NAND partition. Volume name: "nand:0:"
    //
    FS_AddDevice(&FS_NAND_UNI_Driver);
    FS_NAND_UNI_SetPhyType(0, &FS_NAND_PHY_ONFI);
    FS_NAND_UNI_SetECCHook(0, &FS_NAND_ECC_HW_NULL);
    FS_NAND_ONFI_SetHWType(0, &FS_NAND_HW_Template);
    //
    // Add and configure the first logical volume. Volume name: "diskpart:0"
    //
    FS_AddDevice(&FS_DISKPART_Driver);
    FS_DISKPART_Configure(0, &FS_NAND_UNI_Driver, 0, 0);
    //
}
```

```
// Add and configure the second logical volume. Volume name: "diskpart:1"  
//  
FS_AddDevice(&FS_DISKPART_Driver);  
FS_DISKPART_Configure(1, &FS_NAND_UNI_Driver, 0, 1);  
}
```

17.3.1.5 setecclevel

Description

Configures the error correction type.

Syntax

```
setecclevel <NumBitErrors>  
sel          <NumBitErrors>
```

Parameters

Parameter	Description
<code>NumBitErrors</code>	Number of bit errors the ECC stored to spare area must be able to correct. Permitted values are: <ul style="list-style-type: none">• 0 - hardware ECC.• 1 - 1-bit software ECC.

Additional information

This command is optional. If not executed a 1-bit software calculated ECC is stored to spare area. If `NumBitErrors` is set to 0 then the bytes in the spare area reserved for the ECC are set to `0xFF`.

Example

This example shows how to set the correction level to hardware ECC.

```
setecclevel 0
```

17.3.1.6 setnumworkblocks

Description

Configures the number of work blocks.

Syntax

```
setnumworkblocks <NumBlocks>  
snwb             <NumBlocks>
```

Parameters

Parameter	Description
NumBlocks	Number of NAND blocks reserved for work blocks.

Additional information

This command is optional. If this command is not executed the number of work blocks is set to 3. The number of work blocks specified via this command has to match the number of work blocks configured by the target application via `FS_NAND_SetNumWorkBlocks()` or `FS_NAND_UNI_SetNumWorkBlocks()`.

Example

This example shows how to set the number of work blocks to 8.

```
setnumworkblocks 8
```

17.3.1.7 showimageinfo

Description

Shows information about the image file.

Syntax

```
showimageinfo  
si
```

Example

```
showimageinfo  
Name:          nand.bin  
Driver type:   Universal  
Num blocks:    1024  
Pages per block: 64  
Page size:     2048 bytes  
Spare area size: 64 bytes  
Bytes per sector: 2048 bytes
```

17.3.1.8 `init`

Description

Initializes the image file.

Syntax

```
init
```

Additional information

This command must be executed before any other command which operates on files and directories.

Example

```
init
```

17.3.1.9 exportimage

Description

Saves to a file the NAND blocks that contain valid data.

Syntax

```
exportimage <FilePathOnHost>  
ei <FilePathOnHost>
```

Parameters

Parameter	Description
FilePathOnHost	Path to destination file on host PC.

Additional information

This command is optional. It can be used to create an image file that contains only NAND blocks with valid data. The NAND blocks that contain invalid data or are empty are discarded. The created file can be used to program the NAND flash device. The programming utility has to make sure that the NAND blocks that are not programmed are blank that is all the bytes in these blocks are set to 0xFF. Typically, the created file is smaller than the original image file which helps reduce the programming time.

Example

```
exportimage C:\NAND.bin
```

17.3.2 File and directory related commands

The following sections describe the commands that can be used to operate on the files and directories stored on the image file. The commands described in this section can be executed only after the execution of the `init` command.

17.3.2.1 cd

Description

Changes the current working directory.

Syntax

```
chdir <DirPathOnImage>  
cd    <DirPathOnImage>
```

Parameters

Parameter	Description
DirPathOnImage	Path to new directory to change to.

Additional information

If [DirPathOnImage](#) is set to `..` the command changes to the parent directory. After initialization the current directory is set to the root directory.

Example

In the following sample the working directory is changed to `Test` and then back to the original directory.

```
cd Test  
cd ..
```

17.3.2.2 md

Description

Creates a directory.

Syntax

```
mkdir <DirPathOnImage>  
md    <DirPathOnImage>
```

Parameters

Parameter	Description
DirPathOnImage	Path to directory to be created.

Additional information

This command is able to create any missing directories in the path.

Example

```
md Test\Dir\
```

17.3.2.3 rd

Description

Removes a directory.

Syntax

```
rmdir <DirPathOnImage> [/R]  
rd    <DirPathOnImage> [/R]
```

Parameters

Parameter	Description
DirPathOnImage	Path to directory to be deleted.
/R	Option that causes the command to delete non-empty directories.

Additional information

If the /R option is not specified, then the directory to be deleted must be empty.

Example

```
rd Test
```

17.3.2.4 addfile

Description

Copies a file from the host PC to the image file.

Syntax

```
addfile <FilePathOnHost> [<FilePathOnImage>]  
af      <FilePathOnHost> [<FilePathOnImage>]
```

Parameters

Parameter	Description
FilePathOnHost	Path to the source file on host PC.
FilePathOnImage	Path to destination file on the image.

Additional information

If [FilePathOnImage](#) is not specified then the name of the source file is used.

Example

The following command copies the contents of the `Test.txt` file from host PC to `Dest.txt` file on image.

```
addfile C:\Test.txt Dest.txt
```

The following command copies the contents of `Test.txt` file to the file with the same name of the image.

```
addfile C:\Test.txt
```

17.3.2.5 addfolder

Description

Copies a folder including its subfolders and files from the host PC to the image file.

Syntax

```
addfolder <DirPathOnHost> [<DirPathOnImage>] [/S]
```

Parameters

Parameter	Description
<code>DirPathOnHost</code>	Path to source directory on the host PC.
<code>DirPathOnImage</code>	Path to destination directory on the image.
<code>/S</code>	Option that causes the command to suppress the output of progress information.

Additional information

If `DirPathOnImage` is not specified then the name of the source directory is used.

Example

The following command copies the contents of the `Data` directory on PC to `Dest` directory on the image.

```
addfolder C:\Data Dest
```

The following command copies the contents of the `Data` directory on PC to a directory with the same name on the image.

```
addfolder C:\Data
```

17.3.2.6 type

Description

Shows the contents of a file.

Syntax

```
type <FilePathOnImage>
```

Parameters

Parameter	Description
<code>FilePathOnImage</code>	Path to the file on image to be shown.

Example

The following command line shows the contents of the file `Test.txt` located on the root directory of the image.

```
type Test.txt
```

17.3.2.7 del

Description

Deletes a file.

Syntax

```
del <FilePathOnImage>
```

Parameters

Parameter	Description
<code>FilePathOnImage</code>	Path to the file on image to be deleted.

Example

The following command line deletes the file `Test.txt` located on the root directory of the image.

```
del Test.txt
```

17.3.2.8 dir

Description

Lists the contents of the directory.

Syntax

```
ls [<DirPathOnImage>]  
dir [<DirPathOnImage>]
```

Parameters

Parameter	Description
DirPathOnImage	Path to directory on image to be listed.

Additional information

If [DirPathOnImage](#) is not specified then the command lists the contents of the current working directory.

Example

The following command line shows the contents of the directory `TestDir`.

```
dir nand:0:\TestDir  
.  
..  
SubDir  
Test1.txt  
Test2.txt  
(Dir) Attributes: ----  
(Dir) Attributes: ----  
(Dir) Attributes: ----  
Attributes: A--- Size: 30  
Attributes: A--- Size: 31
```

17.3.2.9 ren

Description

Renames a file or directory.

Syntax

```
rename <FilePathOnImage> <NewFileName>  
ren    <FilePathOnImage> <NewFileName>
```

Parameters

Parameter	Description
FilePathOnImage	Path to file or directory that has to be renamed.
NewFileName	New name of the file or directory.

Additional information

If [DirPathOnImage](#) is not specified then the command lists the contents of the current working directory.

Example

The following command line changes the name of `Test.txt` file located in the `Test` directory to `Test2.txt`.

```
ren Test\Test.txt Test2.txt
```

17.3.2.10 move

Description

Moves a file or directory to another location.

Syntax

```
move <SrcFilePathOnImage> <DestFilePathOnImage>  
mv   <SrcFilePathOnImage> <DestFilePathOnImage>
```

Parameters

Parameter	Description
SrcFilePathOnImage	Path to file or directory to be moved.
DestFilePathOnImage	Path to destination file or directory on the image.

Example

The following command line moves the `Test.txt` file located in the `Test` directory to the root directory. The file is renamed to `New.txt`.

```
move Test\Test.txt New.txt
```

17.3.2.11 attr

Description

Shows/changes the file/directory attributes.

Syntax

```
attr <PathOnImage> [<Operation> <Attributes>]
```

Parameters

Parameter	Description
<code>PathOnImage</code>	Path to file or directory.
<code>Operation</code>	Operation to be executed on attributes. Permitted values are: <ul style="list-style-type: none"> • + sets the attributes. • - clears the attributes.
<code>Attributes</code>	The list of attributes to be changed The following attributes are supported: <ul style="list-style-type: none"> • a - archive. • h - hidden. • r - read-only. • s - system.

Example

The following example the clears the archive and read-only attributes of the `Test.txt` file.

```
attr Test.txt -ar
```

17.3.2.12 copy

Description

Copies a file to another location.

Syntax

```
copy <SrcFilePathOnImage> <DestFilePathOnImage>  
cp   <SrcFilePathOnImage> <DestFilePathOnImage>
```

Parameters

Parameter	Description
SrcFilePathOnImage	Path to the file to be copied.
DestFilePathOnImage	Path to destination the file.

Example

The following example copies the contents of the `Test.txt` to the `Test2.txt` file.

```
copy Test.txt Test2.txt
```

17.3.2.13 exportfile

Description

Copies a file from image file to host PC.

Syntax

```
exportfile <FilePathOnImage> <FilePathOnHost>  
ef          <FilePathOnImage> <FilePathOnHost>
```

Parameters

Parameter	Description
<code>FilePathOnImage</code>	Path to the source file on image.
<code>FilePathOnHost</code>	Path to the destination file on PC.

Example

The following command copies the contents of the `Test.txt` file from image to `Dest.txt` file on host PC.

```
exportfile Test.txt C:\Dest.txt
```

17.3.2.14 exportfolder

Description

Copies a directory recursively from image to host PC.

Syntax

```
exportfolder <DirPathOnImage> <DirPathOnHost>
```

Parameters

Parameter	Description
DirPathOnImage	Path to the source directory on image.
DirPathOnHost	Path to the destination directory on PC.

Example

The following command copies the contents of the entire current volume from image to Exported\RootDir directory on host PC.

```
exportfolder \ Exported\RootDir
```

17.3.3 Logical sector related commands

The following sections describe commands that can be used to operate on logical sectors.

17.3.3.1 storesectors

Description

Copies logical sector data from a file on the PC host to image file.

Syntax

```
storesectors <FilePathOnImage> [<StartSector>]
```

Parameters

Parameter	Description
<code>FilePathOnImage</code>	Path to the file on host that contains sector data.
<code>StartSector</code>	Index of the first logical sector to be written.

Additional information

This command is optional. The sector data must be stored sequentially in the file. For example if the sector size is 2048 bytes and the data is stored starting from sector index 100 then the byte at offset 0 in the file stores the first byte of sector 100, the byte at offset 2048 in the file stores the first byte of sector 101 and so on. The size of the file has to be a multiple of sector size. The size of the sector is the size specified as the argument to `setsectorsize` command.

Example

This example reads sector data from the file `SectorData.bin` and writes it starting from sector index 100.

```
storesectors SectorData.bin 100
```

17.3.3.2 dumpsector

Description

Shows the contents of a logical sector.

Syntax

```
dumpsector <SectorIndex>
ds          <SectorIndex>
```

Parameters

Parameter	Description
SectorIndex	Index of the logical sector to be displayed.

Example

The following command shows the contents of the logical sector 0.

```
dumpsector 0
00000000 34 33 32 31 34 33 32 31 34 33 32 31 34 33 32 31 4321432143214321
00000010 34 33 32 31 34 33 32 31 34 33 32 31 34 33 32 31 4321432143214321
00000020 34 33 32 31 34 33 32 31 34 33 32 31 34 33 32 31 4321432143214321
00000030 0D 0A 34 33 32 31 34 33 32 31 34 33 32 31 34 33 ..43214321432143
00000040 32 31 34 33 32 31 34 33 32 31 34 33 32 31 34 33 2143214321432143
00000050 32 31 34 33 32 31 34 33 32 31 34 33 32 31 34 33 2143214321432143
00000060 32 31 0D 0A 34 33 32 31 34 33 32 31 34 33 32 31 21..432143214321
00000070 34 33 32 31 34 33 32 31 34 33 32 31 34 33 32 31 4321432143214321
00000080 34 33 32 31 34 33 32 31 34 33 32 31 34 33 32 31 4321432143214321
00000090 34 33 32 31 0D 0A 34 33 32 31 34 33 32 31 34 33 4321..4321432143
000000A0 32 31 34 33 32 31 34 33 32 31 34 33 32 31 34 33 2143214321432143
000000B0 32 31 34 33 32 31 34 33 32 31 34 33 32 31 34 33 2143214321432143
000000C0 32 31 34 33 32 31 0D 0A 34 33 32 31 34 33 32 31 214321..43214321
000000D0 34 33 32 31 34 33 32 31 34 33 32 31 34 33 32 31 4321432143214321
000000E0 34 33 32 31 34 33 32 31 34 33 32 31 34 33 32 31 4321432143214321
000000F0 34 33 32 31 34 33 32 31 0D 0A 34 33 32 31 34 33 43214321..432143
00000100 32 31 34 33 32 31 34 33 32 31 34 33 32 31 34 33 2143214321432143
00000110 32 31 34 33 32 31 34 33 32 31 34 33 32 31 34 33 2143214321432143
00000120 32 31 34 33 32 31 34 33 32 31 0D 0A 34 33 32 31 2143214321..4321
00000130 34 33 32 31 34 33 32 31 34 33 32 31 34 33 32 31 4321432143214321
00000140 34 33 32 31 34 33 32 31 34 33 32 31 34 33 32 31 4321432143214321
00000150 34 33 32 31 34 33 32 31 34 33 32 31 0D 0A 34 33 432143214321..43
00000160 32 31 34 33 32 31 34 33 32 31 34 33 32 31 34 33 2143214321432143
00000170 32 31 34 33 32 31 34 33 32 31 34 33 32 31 34 33 2143214321432143
00000180 32 31 34 33 32 31 34 33 32 31 34 33 32 31 0D 0A 21432143214321..
00000190 34 33 32 31 34 33 32 31 34 33 32 31 34 33 32 31 4321432143214321
000001A0 34 33 32 31 34 33 32 31 34 33 32 31 34 33 32 31 4321432143214321
000001B0 34 33 32 31 34 33 32 31 34 33 32 31 34 33 32 31 4321432143214321
000001C0 0D 0A 34 33 32 31 34 33 32 31 34 33 32 31 34 33 ..43214321432143
000001D0 32 31 34 33 32 31 34 33 32 31 34 33 32 31 34 33 2143214321432143
000001E0 32 31 34 33 32 31 34 33 32 31 34 33 32 31 34 33 2143214321432143
000001F0 32 31 0D 0A 34 33 32 31 34 33 32 31 34 33 32 31 21..432143214321
```

17.3.3.3 copysectors

Description

Copies logical sector data to another location.

Syntax

```
copysectors <SrcSector> <DestSector> <NumSectors>  
cs          <SrcSector> <DestSector> <NumSectors>
```

Parameters

Parameter	Description
SrcSector	Index of the first source sector.
DestSector	Index of the first destination sector.
NumSectors	Number of sectors to copy.

Additional information

This command operates only on the `nand:0:` volume. The command reports an error if the source and destination sector ranges overlap.

Example

This example copies 10000 logical sectors from sector index 0 to sector index 20000.

```
copysectors 0 20000 10000
```

17.3.4 Volume specific commands

The following sections describe commands that operate on the file system volumes located on the image file.

17.3.4.1 formatlow

Description

Low-level formats a volume.

Syntax

```
formatlow [<VolumeName>]
```

Parameters

Parameter	Description
<code>VolumeName</code>	Name of the volume that has to be formatted.

Additional information

If `VolumeName` is not specified then the command formats the current volume. The current volume can be selected via the `cd` command.

Every NAND volume has to be low-level formatted once when the image file is newly created.

Example

This example demonstrates how to format the volume `nand:1`:

```
formatlow nand:1:  
Low-level format...OK
```

17.3.4.2 format

Description

High-level formats a volume.

Syntax

```
format [<VolumeName>]
```

Parameters

Parameter	Description
<code>VolumeName</code>	Name of the volume that has to be formatted.

Additional information

If `VolumeName` is not specified then the command formats the current first volume. The current volume can be selected via the `cd` command.

Every NAND volume has to be high-level formatted once when the image file is newly created.

Example

This example demonstrates how to format the volume `nand:0`:

```
format
High-level format...OK
```

17.3.4.3 df

Description

Shows the available free space on a volume.

Syntax

```
diskfree [<VolumeName>]  
df      [<VolumeName>]
```

Parameters

Parameter	Description
VolumeName	Name of the volume to be queried.

Additional information

If [VolumeName](#) is not specified than the command calculates the free space of the current volume. The current volume can be selected via the `cd` command.

Example

This example demonstrates how to get the frees space on the first volume.

```
df  
Available free space is 127647744 bytes
```

17.3.4.4 diskinfo

Description

Shows information about a storage device.

Syntax

```
diskinfo [<VolumeName>]  
di      [<VolumeName>]
```

Parameters

Parameter	Description
VolumeName	Name of the volume to be queried.

Additional information

If [VolumeName](#) is not specified then the command returns information about the current volume. The current volume can be selected via the `cd` command.

Example

This example demonstrates how to get information about the volume `nand:1:`.

```
diskinfo nand:1:  
 127647744 bytes total disk space  
 17719296 bytes available free space  
   8192 bytes per cluster  
 15582 cluster available on volume  
   2163 free cluster available on volume
```

17.3.4.5 getdevinfo

Description

Shows information about a volume.

Syntax

```
getdevinfo [<VolumeName>]
```

Parameters

Parameter	Description
<code>VolumeName</code>	Name of the volume to be queried.

Additional information

If `VolumeName` is not specified then the command returns information about the first volume. The current volume can be selected via the `cd` command.

Example

This example demonstrates how to get information about the storage device used by the first volume.

```
getdevinfo
  62370 available sectors
  2048 bytes per sector
```

17.3.4.6 checkdisk

Description

Checks a volume for errors.

Syntax

```
checkdisk [<VolumeName>]  
chkdsk   [<VolumeName>]
```

Parameters

Parameter	Description
VolumeName	Name of the volume to be checked.

Additional information

If [VolumeName](#) is not specified then the command checks the current volume for errors. The current volume can be selected via the `cd` command.

Example

This example demonstrates how to check the file system structure of the first volume.

```
checkdisk
```

17.3.4.7 creatembr

Description

Writes partition table to master boot record (MBR).

Syntax

```
creatembr [<VolumeName>]  
cm       [<VolumeName>]
```

Parameters

Parameter	Description
VolumeName	Name of the volume to be written.

Additional information

If [VolumeName](#) is not specified then the command writes the MBR to the current volume. The current volume can be selected via the `cd` command.

This command stores the partition table configured via `addpartition` command to the MBR of the specified volume. The command has to be executed after the low-level format and before any high-level format operation. Typically, the partition table is located on `nand:0:` volume.

Example

This example stores the MBR to the sector 0 of the `nand:0:` volume.

```
creatembr nand:0:
```

17.3.4.8 listvolumes

Description

Shows the names of all available volumes.

Syntax

```
listvolumes  
lv
```

Example

Shows the names of the volumes of in a configuration using five volumes.

```
listvolumes  
Available volumes:  
  nand:0:  
  diskpart:0:  
  diskpart:1:  
  diskpart:2:  
  diskpart:3:
```

Chapter 18

NOR Image Creator

This chapter provides information about the emFile utility that can be used to create file system images for NOR flash devices.

18.1 General information

The NOR Image Creator is a command line utility that can be used to create a file containing a one-to-one representation of the contents of a NOR flash device (image file) with preselected files and directories found on the host PC.

The NOR Image Creator provides commands for performing standard file system operations such as formatting the storage device low as well as high level, copying files and directories from the host PC to the image file or checking the consistency of the file system structure.

The generated image file is a regular binary file that can be programmed directly into the NOR flash device of the target system via a SEGGER production programmer (<https://www.segger.com/products/flash-in-circuit-programmers/>) or any other third-party utility.

The NOR Image Creator ships with executables for Windows, Linux and macOS systems that can be used to create images for the FAT and EFS file systems.

18.2 Using the NOR Image Creator

The NOR Image Creator utility can be used like any other command line based program. For the ease of usage many commands are kept similar to their DOS counterparts. By entering "?" or just pressing the Enter key an overview of the commands is printed on the screen and it should look like the picture below.

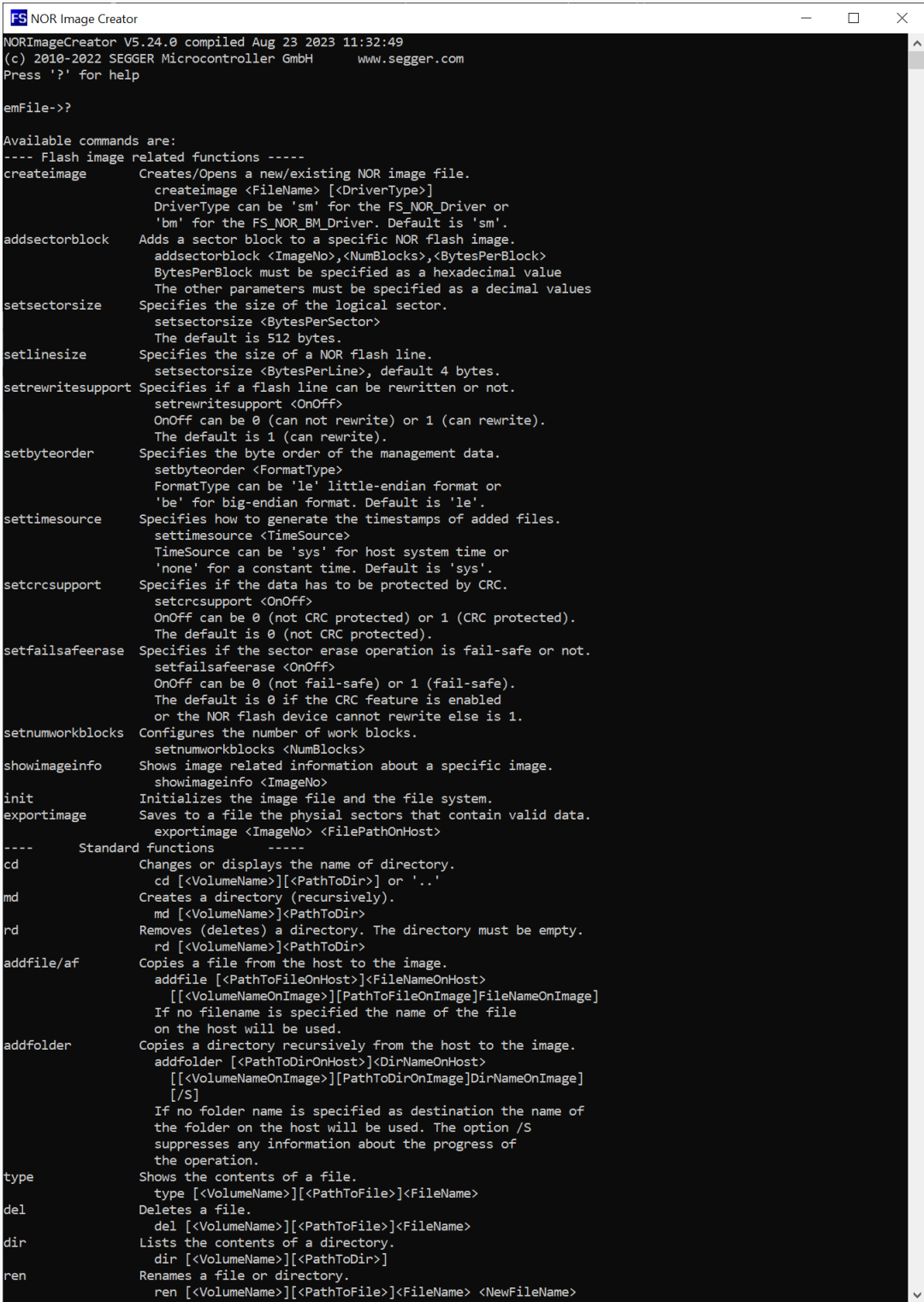

```

FS NOR Image Creator
NORImageCreator V5.24.0 compiled Aug 23 2023 11:32:49
(c) 2010-2022 SEGGER Microcontroller GmbH www.segger.com
Press '?' for help

emFile->?

Available commands are:
---- Flash image related functions ----
createimage Creates/Opens a new/existing NOR image file.
             createimage <FileName> [<DriverType>]
             DriverType can be 'sm' for the FS_NOR_Driver or
             'bm' for the FS_NOR_BM_Driver. Default is 'sm'.
addsectorblock Adds a sector block to a specific NOR flash image.
               addsectorblock <ImageNo>,<NumBlocks>,<BytesPerBlock>
               BytesPerBlock must be specified as a hexadecimal value
               The other parameters must be specified as a decimal values
setsectorsize Specifies the size of the logical sector.
              setsectorsize <BytesPerSector>
              The default is 512 bytes.
setlinesize Specifies the size of a NOR flash line.
            setsectorsize <BytesPerLine>, default 4 bytes.
setrewritesupport Specifies if a flash line can be rewritten or not.
                  setrewritesupport <OnOff>
                  OnOff can be 0 (can not rewrite) or 1 (can rewrite).
                  The default is 1 (can rewrite).
setbyteorder Specifies the byte order of the management data.
             setbyteorder <FormatType>
             FormatType can be 'le' little-endian format or
             'be' for big-endian format. Default is 'le'.
settimesource Specifies how to generate the timestamps of added files.
              settimesource <TimeSource>
              TimeSource can be 'sys' for host system time or
              'none' for a constant time. Default is 'sys'.
setcrcsupport Specifies if the data has to be protected by CRC.
              setcrcsupport <OnOff>
              OnOff can be 0 (not CRC protected) or 1 (CRC protected).
              The default is 0 (not CRC protected).
setfailsafeerase Specifies if the sector erase operation is fail-safe or not.
                 setfailsafeerase <OnOff>
                 OnOff can be 0 (not fail-safe) or 1 (fail-safe).
                 The default is 0 if the CRC feature is enabled
                 or the NOR flash device cannot rewrite else is 1.
setnumworkblocks Configures the number of work blocks.
                 setnumworkblocks <NumBlocks>
showimageinfo Shows image related information about a specific image.
              showimageinfo <ImageNo>
init Initializes the image file and the file system.
exportimage Saves to a file the physical sectors that contain valid data.
            exportimage <ImageNo> <FilePathOnHost>
---- Standard functions ----
cd Changes or displays the name of directory.
   cd [<VolumeName>][<PathToDir>] or '.'
md Creates a directory (recursively).
   md [<VolumeName>]<PathToDir>
rd Removes (deletes) a directory. The directory must be empty.
   rd [<VolumeName>]<PathToDir>
addfile/af Copies a file from the host to the image.
            addfile [<PathToFileOnHost>]<FileNameOnHost>
            [[<VolumeNameOnImage>][<PathToFileOnImage>]<FileNameOnImage>]
            If no filename is specified the name of the file
            on the host will be used.
addfolder Copies a directory recursively from the host to the image.
           addfolder [<PathToDirOnHost>]<DirNameOnHost>
           [[<VolumeNameOnImage>][<PathToDirOnImage>]<DirNameOnImage>]
           [/S]
           If no folder name is specified as destination the name of
           the folder on the host will be used. The option /S
           suppresses any information about the progress of
           the operation.
type Shows the contents of a file.
     type [<VolumeName>][<PathToFile>]<FileName>
del Deletes a file.
     del [<VolumeName>][<PathToFile>]<FileName>
dir Lists the contents of a directory.
     dir [<VolumeName>][<PathToDir>]
ren Renames a file or directory.
     ren [<VolumeName>][<PathToFile>]<FileName> <NewFileName>

```

NOR Image Creator

The NOR Image Creator utility can work in two modes: interactive and script. The interactive mode is entered when the utility is started with no command line arguments. In this mode the user is prompted to type in the commands to be executed. The script mode is entered

when the utility is started with a command line argument that specifies the name of a file containing the commands to be executed, one command per line.

18.2.1 Sample script file

The following sample shows a simple script file which does the following thing:

- Creates a NOR flash image file `C:\flash.bin`
- Adds a sector block of 4 Mbytes (64 x 64 kByte) to the image file.
- Creates the image file.
- Low-level formats the volume on the image file.
- High-level formats the volume on the image file.
- Copies the `Test.txt` file from drive `C:` of the host Windows PC to root directory of the volume stored on the image file.
- Copies recursively the contents of `Data` directory from host PC to `Data` directory of the volume stored on the image file.
- Closes the NOR Image Creator utility.

```
createimage C:\flash.bin
addsectorblock 0, 64, 10000
init
formatlow
format
addfile C:\Test.txt
addfolder C:\Data\
q
```

18.3 Supported commands

The image file can be processed by using build it commands of the NAND Image Creator utility. The table below lists all the available commands followed by a detailed description. The optional command parameters are enclosed in square brackets in the syntax description of a command. If not otherwise stated all the numeric parameters have to be specified as decimal format.

Command	Description
Image related commands	
<code>createimage</code>	Creates/opens a new/existing image file.
<code>addsectorblock</code>	Configures a block of NOR physical sectors.
<code>setsectorsize</code>	Configures the logical sector size.
<code>setlinesize</code>	Specifies the minimum number of bytes that can be programmed at once
<code>setrewritesupport</code>	Configures if the NOR driver is allowed to perform rewrite operations.
<code>setbyteorder</code>	Specifies the byte order of the management data.
<code>settimesource</code>	Specifies how the timestamps of added files are generated.
<code>setcrcsupport</code>	Specifies if the data has to be protected by CRC.
<code>setnumworkblocks</code>	Configures the number of work blocks.
<code>showimageinfo</code>	Shows information about the image file.
<code>init</code>	Initializes the image file.
<code>exportimage</code>	Saves to a file the NOR physical sectors that contain valid data.
File and directory related commands	
<code>cd</code>	Changes the current working directory.
<code>md</code>	Creates a directory.
<code>rd</code>	Removes a directory.
<code>addfile</code>	Copies a file from the host PC to the image file.
<code>addfolder</code>	Copies a folder including its subfolders and files from the host PC to the image file.
<code>type</code>	Shows the contents of a file.
<code>del</code>	Deletes a file.
<code>dir</code>	Lists the contents of the directory.
<code>ren</code>	Renames a file or directory.
<code>move</code>	Moves a file or directory to another location.
<code>attrib</code>	Shows/changes the file/directory attributes.
<code>copy</code>	Copies a file to another location.
<code>exportfile</code>	Copies a file from image file to host PC.
<code>exportfolder</code>	Copies a folder including its subfolders and files from image file to host PC.
Volume specific commands	
<code>formatlow</code>	Low-level formats a volume.
<code>format</code>	High-level formats a volume.
<code>df</code>	Shows the available free space on a volume.
<code>diskinfo</code>	Shows information about a volume.
<code>getdevinfo</code>	Shows information about a storage device.

Command	Description
<code>checkdisk</code>	Checks a volume for errors.
<code>listvol</code>	Shows the names of all available volumes.
<code>clean</code>	Runs a clean operation on a volume.
<code>createjournal</code>	Creates the journal file on a volume.

18.3.1 Image related commands

The following sections describe the commands required to create an image file.

18.3.1.1 createimage

Description

Creates/opens a new/existing image file.

Syntax

```
createimage <ImageFileName>[,<DriverType>]
```

Parameters

Parameter	Description
ImageFileName	Name of the image file to be created/opened.
DriverType	The type of NAND driver used to access the files on the target. <ul style="list-style-type: none">• sm - Sector Map NOR driver (default).• bm - Block Map NOR driver.

Additional information

This command is mandatory and it must be the first command to be executed.

If [DriverType](#) is not specified then the Sector Map NOR driver is assumed.

Example

The example shows how to create an image file for the Block Map NOR driver.

```
createimage C:\flash.bin bm
```

18.3.1.2 addsectorblock

Description

Configures a block of NOR physical sectors.

Syntax

```
addsectorblock <ImageNo>,<NumSectors>,<SectorSize>
```

Parameters

Parameter	Description
ImageNo	Index of the image file.
NumSectors	Number of NOR physical sectors in the block.
SectorSize	Size of one NOR physical sector.

Additional information

This command is mandatory and has to be executed at least once. `addsectorblock` can be used to describe the geometry of the physical NOR flash device used on the target. It specifies the characteristics of a continuous block of NOR physical sectors. The command can be executed more than once with different parameters. [SectorSize](#) has to be specified in bytes as a hexadecimal number without any prefix or suffix. For example a NOR physical sector of 64 Kbytes can be specified as 10000.

[ImageNo](#) specifies the index of the image file. The first image file created via `createimage` has the index 0, the second image the index 1 and so on.

Example

The following example shows how to configure the image for a NOR flash device that has 32 physical sectors of 64 Kbytes and 8 physical sectors of 4 Kbytes.

```
addsectorblock 0,32,10000
addsectorblock 0,8,1000
```

18.3.1.3 setsectorsize

Description

Configures the logical sector size.

Syntax

```
setsectorsize <SectorSize>
```

Parameters

Parameter	Description
<code>SectorSize</code>	The size of the logical sector in bytes.

Additional information

This command is optional. It can be used to set the size of the logical sector used by the file system. By default the file system uses a logical sector size of 512 bytes. The size of the logical sector as to be smaller than or equal to the size of the logical sector configured on the target application via `FS_SetMaxSectorSize()`.

`SectorSize` has to be a power of 2 value.

Example

This example shows how to set the logical sector size to 512 bytes.

```
setsectorsize 2038
```

18.3.1.4 setlinesize

Description

Specifies the minimum number of bytes that can be programmed at once.

Syntax

```
setlinesize <LineSize>
```

Parameters

Parameter	Description
LineSize	Minimum number of bytes that can be programmed at once.

Additional information

This command is optional. By default, the minimum number of bytes that the NOR driver programs is 4. [LineSize](#) has to be a power of 2 value.

Example

This example shows how to set the line size to 16 bytes.

```
setlinesize 16
```

18.3.1.5 setrewritesupport

Description

Configures if the NOR driver is allowed to perform rewrite operations.

Syntax

```
setrewritesupport <OnOff>
```

Parameters

Parameter	Description
OnOff	Indicates if the feature is activated or not. <ul style="list-style-type: none">• 1 - NOR driver is permitted to rewrite data (default).• 0 - NOR driver is not permitted to rewrite data.

Additional information

This command is optional. By default, the NOR driver is permitted to modify the same byte of the NOR flash device memory as long as bits are changed from 0 to 1 without an erase operation in between. The majority of NOR flash devices support this feature but some are not. For this type of NOR flash devices this command has to be called with [OnOff](#) set to 0.

Example

This example shows how to specify that the NOR flash can rewrite data.

```
setrewritesupport 1
```

18.3.1.6 setbyteorder

Description

Specifies the byte order of the management data.

Syntax

```
setbyteorder <FormatType>
```

Parameters

Parameter	Description
<code>FormatType</code>	Specifies the byte ordering. <ul style="list-style-type: none">• <code>le</code> - little endian format.• <code>be</code> - big endian format.

Additional information

This command is optional. By default, the NOR driver stores multi-byte management data in the byte order of the host CPU which is typically little-endian. The byte order of the management data has to match the byte order of the target CPU. `setbyteorder` can be used to explicitly configure the byte order.

Example

This example shows how to configure the byte order to big-endian.

```
setbyteorder be
```

18.3.1.7 settimesource

Description

Specifies how the timestamps of added files are generated.

Syntax

```
settimesource <TimeSource>
```

Parameters

Parameter	Description
<code>TimeSource</code>	Specifies the time source to be used. <ul style="list-style-type: none"><code>sys</code> - time of host PC (default).<code>none</code> - constant value.

Additional information

This command is optional. By default, the NOR Image Creator uses the current time and date of the host PC to generate the timestamps of the files and directories. In some cases it is desirable to have the same constant time stamp for all the files and directories stored on the image file so that for example the generated image file can be compared correctness against a reference image file.

Example

This example shows how to configure the NOR Image Creator to use a constant time stamp for all the files and directories it creates on the image file.

```
settimesource none
```

18.3.1.8 setcrcsupport

Description

Specifies if the data has to be protected by CRC.

Syntax

```
setcrcsupport <OnOff>
```

Parameters

Parameter	Description
OnOff	Indicates if the feature is activated or not. <ul style="list-style-type: none">• 1 - Data is protected by CRC.• 0 - Data is not protected by CRC (default).

Additional information

This command is optional. By default, the management and user data stored by the NOR driver is not protected by CRC.

Example

This example shows how to configure the NOR Image Creator to protect the data via CRC.

```
setcrcsupport 1
```

18.3.1.9 setnumworkblocks

Description

Configures the number of work blocks.

Syntax

```
setnumworkblocks <NumWorkBlocks>
```

Parameters

Parameter	Description
<code>NumWorkBlocks</code>	Number of work blocks.

Additional information

This command is optional and applies only to Block Map NOR driver. By default, the Block Map NOR driver calculates the number of work blocks automatically based on the number of physical sectors available as storage. The setnumworkblocks command can be used to overwrite the calculated value. NumWorkBlocks has to be set to a value greater than 0.

Example

This example shows how to set the number of work blocks to 8.

```
setnumworkblocks 8
```

18.3.1.10 showimageinfo

Description

Shows information about the image file.

Syntax

```
showimageinfo <ImageNo>
```

Parameters

Parameter	Description
ImageNo	Index of the image file.

Example

```
showimageinfo
Information about image 0:
Name:          NORImageCreator_NOR.img
ImageSize:     8388608 bytes
NumSectorBlocks: 1
  Block 0: 128 sectors of 0x00010000 bytes
```

18.3.1.11 `init`

Description

Initializes the image file.

Syntax

```
init
```

Additional information

This command must be executed before any other command which operates on files and directories.

Example

```
init
```

18.3.1.12 exportimage

Description

Saves to a file the NOR physical sectors that contain valid data.

Syntax

```
exportimage <FilePathOnHost>  
ei <FilePathOnHost>
```

Parameters

Parameter	Description
FilePathOnHost	Path to destination file on host PC.

Additional information

This command is optional. It can be used to create an image file that contains only NOR physical sectors with valid data. The NOR physical sectors that contain invalid data or are empty are discarded. The created file can be used to program the NOR flash device. The programming utility has to make sure that the NOR physical sectors that are not programmed are blank that is all the bytes in these physical sectors are set to `0xFF`. Typically, the created file is smaller than the original image file which helps reduce the programming time.

Example

```
exportimage C:\NAND.bin
```

18.3.2 File and directory related commands

The following sections describe the commands that can be used to operate on the files and directories stored on the image file. The commands described in this section can be executed only after the execution of the `init` command.

18.3.2.1 cd

Description

Changes the current working directory.

Syntax

```
cd <DirPathOnImage>
```

Parameters

Parameter	Description
DirPathOnImage	Path to new directory to change to.

Additional information

If [DirPathOnImage](#) is set to `..` the command changes to the parent directory. After initialization the current directory is set to the root directory.

Example

In the following sample the working directory is changed to `Test` and then back to the original directory.

```
cd Test
cd ..
```

18.3.2.2 md

Description

Creates a directory.

Syntax

```
md <DirPathOnImage>
```

Parameters

Parameter	Description
DirPathOnImage	Path to directory to be created.

Additional information

This command is able to create any missing directories in the path.

Example

```
md Test\Dir\
```

18.3.2.3 rd

Description

Removes a directory.

Syntax

```
rd <DirPathOnImage>
```

Parameters

Parameter	Description
DirPathOnImage	Path to directory to be deleted.

Additional information

The directory to be deleted must be empty.

Example

```
rd Test
```

18.3.2.4 addfile

Description

Copies a file from the host PC to the image file.

Syntax

```
addfile <FilePathOnHost> [<FilePathOnImage>]
```

Parameters

Parameter	Description
<code>FilePathOnHost</code>	Path to the source file on host PC.
<code>FilePathOnImage</code>	Path to destination file on the image.

Additional information

If `FilePathOnImage` is not specified then the name of the source file is used.

Example

The following command copies the contents of the `Test.txt` file from host PC to `Dest.txt` file on image.

```
addfile C:\Test.txt Dest.txt
```

The following command copies the contents of `Test.txt` file to the file with the same name of the image.

```
addfile C:\Test.txt
```

18.3.2.5 addfolder

Description

Copies a folder including its subfolders and files from the host PC to the image file.

Syntax

```
addfolder <DirPathOnHost> [<DirPathOnImage>]
```

Parameters

Parameter	Description
DirPathOnHost	Path to source directory on the host PC.
DirPathOnImage	Path to destination directory on the image.

Additional information

If [DirPathOnImage](#) is not specified then the name of the source directory is used.

Example

The following command copies the contents of the `Data` directory on PC to `Dest` directory on the image.

```
addfolder C:\Data Dest
```

The following command copies the contents of the `Data` directory on PC to a directory with the same name on the image.

```
addfolder C:\Data
```

18.3.2.6 type

Description

Shows the contents of a file.

Syntax

```
type <FilePathOnImage>
```

Parameters

Parameter	Description
<code>FilePathOnImage</code>	Path to the file on image to be shown.

Example

The following command line shows the contents of the file `Test.txt` located on the root directory of the image.

```
type Test.txt
```

18.3.2.7 del

Description

Deletes a file.

Syntax

```
del <FilePathOnImage>
```

Parameters

Parameter	Description
<code>FilePathOnImage</code>	Path to the file on image to be deleted.

Example

The following command line deletes the file `Test.txt` located on the root directory of the image.

```
del Test.txt
```

18.3.2.8 dir

Description

Lists the contents of the directory.

Syntax

```
dir [<DirPathOnImage>]
```

Parameters

Parameter	Description
DirPathOnImage	Path to directory on image to be listed.

Additional information

If [DirPathOnImage](#) is not specified then the command lists the contents of the current working directory.

Example

The following command line shows the contents of the current directory.

```
dir
TestDir          (Dir) Attributes: ----
.                (Dir) Attributes: ----
..               (Dir) Attributes: ----
SubDir           (Dir) Attributes: ----
Test1.txt        Attributes: A--- Size: 30
Test2.txt        Attributes: A--- Size: 31
```

18.3.2.9 ren

Description

Renames a file or directory.

Syntax

```
ren <FilePathOnImage> <NewFileName>
```

Parameters

Parameter	Description
FilePathOnImage	Path to file or directory that has to be renamed.
NewFileName	New name of the file or directory.

Additional information

If [DirPathOnImage](#) is not specified then the command lists the contents of the current working directory.

Example

The following command line changes the name of `Test.txt` file located in the `Test` directory to `Test2.txt`.

```
ren Test\Test.txt Test2.txt
```

18.3.2.10 move

Description

Moves a file or directory to another location.

Syntax

```
move <SrcFilePathOnImage> <DestFilePathOnImage>
```

Parameters

Parameter	Description
SrcFilePathOnImage	Path to file or directory to be moved.
DestFilePathOnImage	Path to destination file or directory on the image.

Example

The following command line moves the `Test.txt` file located in the `Test` directory to the root directory. The file is renamed to `New.txt`.

```
move Test\Test.txt New.txt
```

18.3.2.11 attrib

Description

Shows/changes the file/directory attributes.

Syntax

```
attrib <PathOnImage> [<Operation> <Attributes>]
```

Parameters

Parameter	Description
<code>PathOnImage</code>	Path to file or directory.
<code>Operation</code>	Operation to be executed on attributes. Permitted values are: <ul style="list-style-type: none"> • + sets the attributes. • - clears the attributes.
<code>Attributes</code>	The list of attributes to be changed The following attributes are supported: <ul style="list-style-type: none"> • a archive. • h hidden. • r read-only. • s system.

Example

The following example the clears the archive and read-only attributes of the `Test.txt` file.

```
attr Test.txt -ar
```

18.3.2.12 copy

Description

Copies a file to another location.

Syntax

```
copy <SrcFilePathOnImage> <DestFilePathOnImage>
```

Parameters

Parameter	Description
SrcFilePathOnImage	Path to the file to be copied.
DestFilePathOnImage	Path to destination the file.

Example

The following example copies the contents of the `Test.txt` to the `Test2.txt` file.

```
copy Test.txt Test2.txt
```

18.3.2.13 exportfile

Description

Copies a file from image file to host PC.

Syntax

```
exportfile <FilePathOnImage> <FilePathOnHost>
```

Parameters

Parameter	Description
<code>FilePathOnImage</code>	Path to the source file on image.
<code>FilePathOnHost</code>	Path to the destination file on PC.

Example

The following command copies the contents of the `Test.txt` file from image to `Dest.txt` file on host PC.

```
exportfile Test.txt C:\Dest.txt
```

18.3.2.14 exportfolder

Description

Copies a folder including its subfolders and files from image file to host PC.

Syntax

```
exportfolder <DirPathOnImage> <DirPathOnHost>
```

Parameters

Parameter	Description
DirPathOnImage	Path to the source directory on image.
DirPathOnHost	Path to the destination directory on PC.

Additional information

The command copies the contents of a folder including all the folders and the files that are stored in it. An identical copy of the specified directory on the image file is created on the specified folder of the host PC.

Example

The following command copies the contents of the `Data` directory on the image file to `C:\Dest` directory on the host PC.

```
addfolder Data C:\Dest
```

18.3.3 Volume specific commands

The following sections describe commands that operate on the file system volumes located on the image file.

18.3.3.1 formatlow

Description

Low-level formats a volume.

Syntax

```
formatlow [<VolumeName>]
```

Parameters

Parameter	Description
VolumeName	Name of the volume that has to be formatted.

Additional information

If [VolumeName](#) is not specified then the command formats the current volume. The current volume can be selected via the `cd` command.

Every NOR volume has to be low-level formatted once when the image file is newly created.

Example

This example demonstrates how to format the volume `nor:1:`

```
formatlow nor:1:  
Low-level format...OK
```

18.3.3.2 format

Description

High-level formats a volume.

Syntax

```
format [<VolumeName>]
```

Parameters

Parameter	Description
<code>VolumeName</code>	Name of the volume that has to be formatted.

Additional information

If `VolumeName` is not specified then the command formats the current first volume. The current volume can be selected via the `cd` command.

Every NOR volume has to be high-level formatted once when the image file is newly created.

Example

This example demonstrates how to format the volume `nor:0:`

```
format
High-level format...OK
```

18.3.3.3 df

Description

Shows the available free space on a volume.

Syntax

```
df [<VolumeName>]
```

Parameters

Parameter	Description
VolumeName	Name of the volume to be queried.

Additional information

If [VolumeName](#) is not specified than the command calculates the free space of the current volume. The current volume can be selected via the `cd` command.

Example

This example demonstrates how to get the frees space on the first volume.

```
df
Available free space is 127647744 bytes
```

18.3.3.4 diskinfo

Description

Shows information about a storage device.

Syntax

```
diskinfo [<VolumeName>]
```

Parameters

Parameter	Description
VolumeName	Name of the volume to be queried.

Additional information

If [VolumeName](#) is not specified then the command returns information about the current volume. The current volume can be selected via the `cd` command.

Example

This example demonstrates how to get information about the volume `nor:1:`.

```
diskinfo nor:1:
  7333888 bytes total disk space
  7333888 bytes available free space

    1024 bytes per cluster
    7162 cluster available on volume
    7162 free cluster available on volume
```

18.3.3.5 getdevinfo

Description

Shows information about a volume.

Syntax

```
getdevinfo [<VolumeName>]
```

Parameters

Parameter	Description
<code>VolumeName</code>	Name of the volume to be queried.

Additional information

If `VolumeName` is not specified then the command returns information about the first volume. The current volume can be selected via the `cd` command.

Example

This example demonstrates how to get information about the storage device used by the first volume.

```
getdevinfo
  14399 Available sectors
    512 bytes per sector

      0 sectors per track
      0 number of heads
```

18.3.3.6 checkdisk

Description

Checks a volume for errors.

Syntax

```
checkdisk [<VolumeName>]
```

Parameters

Parameter	Description
<code>VolumeName</code>	Name of the volume to be checked.

Additional information

If `VolumeName` is not specified then the command checks the current volume for errors. The current volume can be selected via the `cd` command.

Example

This example demonstrates how to check the file system structure of the first volume.

```
checkdisk
```

18.3.3.7 listvol

Description

Shows the names of all available volumes.

Syntax

```
listvol
```

Example

Shows the names of the volumes of in a configuration using five volumes.

```
listvol
Available volumes:
nor:0:
```

18.3.3.8 clean

Description

Runs a clean operation on a volume.

Syntax

```
clean [<VolumeName>]
```

Parameters

Parameter	Description
<code>VolumeName</code>	Name of the volume to be cleaned.

Additional information

If `VolumeName` is not specified then the command cleans the current volume. The current volume can be selected via the `cd` command.

Example

This example demonstrates how to clean the volume `nor:1:`.

```
clean nor:1:
```

18.3.3.9 createjournal

Description

Creates the journal file on a volume.

Syntax

```
createjournal [<VolumeName>][<PathToFile>]<FileName>
             <JournalSize> [<SupportFreeSector>]
```

Parameters

Parameter	Description
VolumeName	Name of the volume that stores the journal file.
PathToFile	Path to the journal file.
FileName	Name of the journal file.
JournalSize	Size of the journal file.
SupportFreeSector	Size of the journal file.

Additional information

If [VolumeName](#) is not specified then the command creates the journal on the current volume. The current volume can be selected via the `cd` command. If [PathToFile](#) is not specified then the journal file is created on the root directory of the specified volume. [JournalSize](#) has to be specified in bytes. The value of [SupportFreeSector](#) is passed as third argument to `FS_JOURNAL_CreateEx()`. If not specified [SupportFreeSector](#) is set to 0.

The parameters passed to the `createjournal` command have to match the parameters passed to `FS_JOURNAL_CreateEx()` on the target application.

Example

This example demonstrates how to create a journal file of 128 Kbytes on the current volume.

```
createjournal Journal.dat 131072 1
Create journal file 'Journal.dat'...OK
```

Chapter 19

Storage Image Creator

This chapter provides information about the emFile utility that can be used to create file system image for an SD card, an eMMC device or a USB drive.

19.1 General information

The Storage Image Creator is a command line utility that can be used to create a file containing a one-to-one representation of the contents of a managed storage device such as SD card, eMMC device or USB drive, with preselected files and directories found on the host PC.

The Storage Image Creator provides commands for performing standard file system operations such as formatting the storage device, copying files and directories from the host PC to the image file or checking the consistency of the file system structure.

The generated image file is a regular binary file that stores the contents of all the logical sectors of the storage device. This file has to be stored via an image writer utility to the target storage device.

The Storage Image Creator ships with executables for Windows, Linux and macOS systems that can be used to create images for the FAT and EFS file systems.

19.2 Using the Storage Image Creator

The Storage Image Creator utility can be used like any other command line based program. For the ease of usage many commands are kept similar to their MS DOS counterparts. By entering "?" or just pressing the Enter key an overview of the commands is printed on the screen and it should look like the picture below.

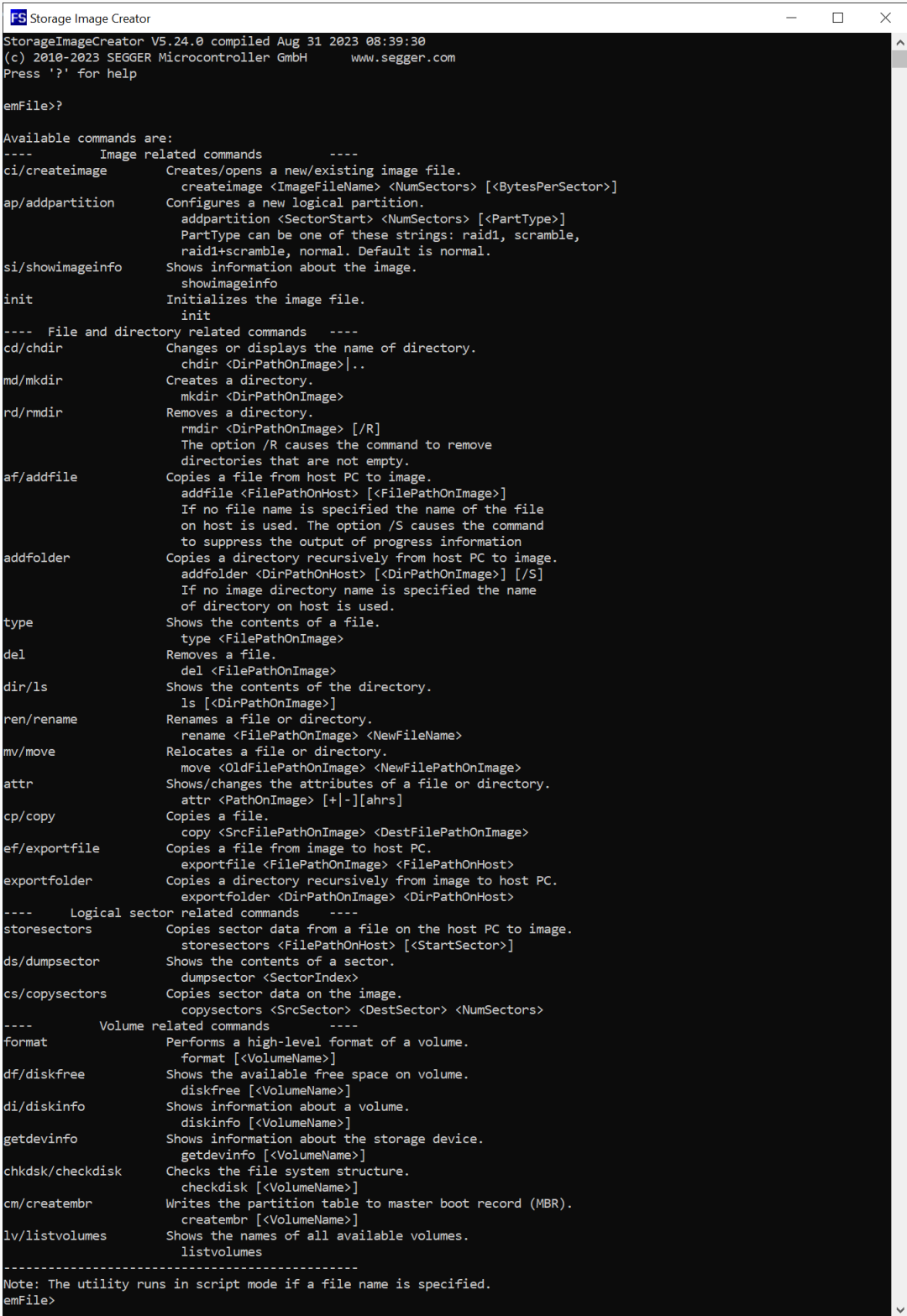

```

Storage Image Creator
StorageImageCreator V5.24.0 compiled Aug 31 2023 08:39:30
(c) 2010-2023 SEGGER Microcontroller GmbH      www.segger.com
Press '?' for help

emFile>?

Available commands are:
----          Image related commands          ----
ci/createimage      Creates/opens a new/existing image file.
                    createimage <ImageFileName> <NumSectors> [<BytesPerSector>]
ap/addpartition     Configures a new logical partition.
                    addpartition <SectorStart> <NumSectors> [<PartType>]
                    PartType can be one of these strings: raid1, scramble,
                    raid1+scramble, normal. Default is normal.
si/showimageinfo   Shows information about the image.
                    showimageinfo
init               Initializes the image file.
                    init
----          File and directory related commands          ----
cd/chdir           Changes or displays the name of directory.
                    chdir <DirPathOnImage>[..]
md/mkdir           Creates a directory.
                    mkdir <DirPathOnImage>
rd/rmdir           Removes a directory.
                    rmdir <DirPathOnImage> [/R]
                    The option /R causes the command to remove
                    directories that are not empty.
af/addfile         Copies a file from host PC to image.
                    addfile <FilePathOnHost> [<FilePathOnImage>]
                    If no file name is specified the name of the file
                    on host is used. The option /S causes the command
                    to suppress the output of progress information
addfolder          Copies a directory recursively from host PC to image.
                    addfolder <DirPathOnHost> [<DirPathOnImage>] [/S]
                    If no image directory name is specified the name
                    of directory on host is used.
type              Shows the contents of a file.
                    type <FilePathOnImage>
del               Removes a file.
                    del <FilePathOnImage>
dir/ls            Shows the contents of the directory.
                    ls [<DirPathOnImage>]
ren/rename        Renames a file or directory.
                    rename <FilePathOnImage> <NewFileName>
mv/move           Relocates a file or directory.
                    move <OldFilePathOnImage> <NewFilePathOnImage>
attr              Shows/changes the attributes of a file or directory.
                    attr <PathOnImage> [+|-][ahrs]
cp/copy           Copies a file.
                    copy <SrcFilePathOnImage> <DestFilePathOnImage>
ef/exportfile     Copies a file from image to host PC.
                    exportfile <FilePathOnImage> <FilePathOnHost>
exportfolder      Copies a directory recursively from image to host PC.
                    exportfolder <DirPathOnImage> <DirPathOnHost>
----          Logical sector related commands          ----
storesectors      Copies sector data from a file on the host PC to image.
                    storesectors <FilePathOnHost> [<StartSector>]
ds/dumpsector     Shows the contents of a sector.
                    dumpsector <SectorIndex>
cs/copysectors    Copies sector data on the image.
                    copysectors <SrcSector> <DestSector> <NumSectors>
----          Volume related commands          ----
format            Performs a high-level format of a volume.
                    format [<VolumeName>]
df/diskfree       Shows the available free space on volume.
                    diskfree [<VolumeName>]
di/diskinfo       Shows information about a volume.
                    diskinfo [<VolumeName>]
getdevinfo        Shows information about the storage device.
                    getdevinfo [<VolumeName>]
chkdsk/checkdisk Checks the file system structure.
                    checkdisk [<VolumeName>]
cm/creatembr      Writes the partition table to master boot record (MBR).
                    creatembr [<VolumeName>]
lv/listvolumes    Shows the names of all available volumes.
                    listvolumes
-----
Note: The utility runs in script mode if a file name is specified.
emFile>

```

Storage Image Creator

The Storage Image Creator utility can work in two modes: interactive and script. The interactive mode is entered when the utility is started with no command line arguments. In

this mode the user is prompted to type in the commands to be executed. The script mode is entered when the utility is started with a command line argument that specifies the name of a file containing the commands to be executed, one command per line.

19.2.1 Example script file

This is an example script file that performs the following operations:

- Creates a 2 GB image file located at C:\Temp\SDCard.bin
- Initializes the image file.
- High-level formats the volume on the image file.
- Copies the Test.txt file from C:\Temp folder of the host Windows PC to root directory of the volume stored contained in the image file.
- Copies recursively the contents of C:\Temp\Data directory from host PC to Data directory located in the root directory of the volume contained in the image file.

```
createimage C:\Temp\SDCard.bin 4194304
init
format
addfile C:\Temp\Test.txt
addfolder C:\Temp\Data
q
```

19.2.2 Example usage

A step by step example usage that demonstrates how to create an image for an eMMC device can be found by following this link: https://wiki.segger.com/Creating_an_eMMC_image_using_Storage_Image_Creator

19.3 Supported commands

The image file can be processed by using the commands of the Storage Image Creator utility. The table below lists all the available commands followed by a detailed description. The optional command parameters are enclosed in square brackets in the syntax description of a command.

Command	Description
Image related commands	
<code>createimage</code>	Creates/opens a new/existing image file.
<code>addpartition</code>	Configures a logical partition.
<code>showimageinfo</code>	Shows information about the image file.
<code>init</code>	Initializes the image file.
<code>exportimage</code>	Saves to a file the logical sectors that contain valid data.
File and directory related commands	
<code>cd</code>	Changes the current working directory.
<code>md</code>	Creates a directory.
<code>rd</code>	Removes a directory.
<code>addfile</code>	Copies a file from the host PC to the image file.
<code>addfolder</code>	Copies a folder including its subfolders and files from the host PC to the image file.
<code>type</code>	Shows the contents of a file.
<code>del</code>	Deletes a file.
<code>dir</code>	Lists the contents of the directory.
<code>ren</code>	Renames a file or directory.
<code>move</code>	Moves a file or directory to another location.
<code>attr</code>	Shows/changes the file/directory attributes.
<code>copy</code>	Copies a file to another location.
<code>exportfile</code>	Copies a file from image file to host PC.
<code>exportfolder</code>	Copies a directory recursively from image to host PC.
Logical sector related commands	
<code>storesectors</code>	Copies logical sector data from a file on the PC host to image file.
<code>dumpsector</code>	Shows the contents of a logical sector.
<code>copysectors</code>	Copies logical sector data to another location.
Volume related commands	
<code>format</code>	High-level formats a volume.
<code>df</code>	Shows the available free space on a volume.
<code>diskinfo</code>	Shows information about a volume.
<code>getdevinfo</code>	Shows information about a storage device.
<code>checkdisk</code>	Checks a volume for errors.
<code>creatembr</code>	Writes partition table to master boot record (MBR).
<code>listvolumes</code>	Shows the names of all available volumes.
<code>createjournal</code>	Creates the journal file on a volume.

19.3.1 Image related commands

The following sections describe the commands required to create an image file.

19.3.1.1 createimage

Description

Creates/opens a new/existing image file.

Syntax

```
createimage <ImageFileName> <NumSectors> [<SectorSize>]  
ci <ImageFileName> <NumSectors> [<SectorSize>]
```

Parameters

Parameter	Description
ImageFileName	Name of the image file to be created/opened.
NumSectors	Number of logical sectors in the image.
SectorSize	Number of bytes in a logical sector.

Additional information

This command is mandatory and it must be the first command to be executed.

The size of the created image file is [NumSectors](#) * [SectorSize](#) bytes large. The image file is silently overwritten if the image file already exists but the calculated size of the file does not match. If [SectorSize](#) is not specified then the utility uses logical sectors of 512 bytes.

[SectorSize](#) has to be a power of 2 value.

Example

The example shows how to create 1 GB image file.

```
createimage C:\Temp\SDcard.bin 2097152
```

19.3.1.2 addpartition

Description

Configures a logical partition.

Syntax

```
addpartition <StartSector> <NumSectors>
ap          <StartSector> <NumSectors>
```

Parameters

Parameter	Description
<code>StartSector</code>	Index of the first sector in the partition.
<code>NumSectors</code>	Number of sectors in the partition.

Additional information

This command is optional. It allows the creation of logical partitions on the image file. The command fails if the defined sector range overlaps the range of an already defined logical partition. A maximum of four logical partitions can be created. The partition list has to be stored to image after initialization of the image using the `createmb` command. The data on the created logical partitions can be accessed using the Disk Partition driver. The logical partitions can be formatted using the `format` command. The value of `StartSector` is relative to the beginning of the storage device.

Example

This example shows how to configure 2 logical partitions. The sector 0 is reserved for Master Boot Record where the partition list is stored.

```
addpartition 1 10000
addpartition 10001 20000
```

A possible emFile configuration that allows the application to access the logical partitions looks like this:

```
#include <FS.h>
#include "FS_MMC_HW_CM_Template.h"

#define ALLOC_SIZE      0x9000          // Memory pool for the file system in bytes

static U32 _aMemBlock[ALLOC_SIZE / 4]; // Memory pool used for semi-dynamic allocation.

void FS_X_AddDevices(void) {
    FS_AssignMemory(&_aMemBlock[0], sizeof(_aMemBlock));
    FS_SetMaxSectorSize(2048);
    //
    // Add and configure the SD card partition. Volume name: "mmc:0:"
    //
    FS_AddDevice(&FS_MMC_CM_Driver);
    FS_MMC_CM_SetHWType(0, &FS_MMC_HW_CM_Template);
    //
    // Add and configure the first logical volume. Volume name: "diskpart:0"
    //
    FS_AddDevice(&FS_DISKPART_Driver);
    FS_DISKPART_Configure(0, &FS_MMC_CM_Driver, 0, 0);
    //
    // Add and configure the second logical volume. Volume name: "diskpart:1"
    //
    FS_AddDevice(&FS_DISKPART_Driver);
    FS_DISKPART_Configure(1, &FS_MMC_CM_Driver, 0, 1);
}
```

19.3.1.3 showimageinfo

Description

Shows information about the image file.

Syntax

```
showimageinfo  
si
```

Example

```
showimageinfo  
File name:          SDCard.bin  
File size:          1073741824 bytes  
Number of sectors: 2097152  
Sector size:       512 bytes
```

19.3.1.4 `init`

Description

Initializes the image file.

Syntax

```
init
```

Additional information

This command must be executed before any other command which operates on files and directories.

Example

```
init
```

19.3.1.5 exportimage

Description

Saves to a file the logical sectors that contain valid data.

Syntax

```
exportimage <FilePathOnHost> [FileType]
ei <FilePathOnHost> [FileType]
```

Parameters

Parameter	Description
<code>FilePathOnHost</code>	Path to destination file on host PC.
<code>FileType</code>	Format of the created file. Permitted values are: <ul style="list-style-type: none"> <code>trim</code> - Binary file that stores the data of all the logical up to and including the last that contains valid data (default). <code>srec</code> - Motorola S-record file that stores only the logical sectors that contain valid data. <code>sblk</code> - Binary file that stores the data of all valid logical sectors.

Additional information

This command can be used to extract the contents of all the logical sectors that contain valid data from the image file to an export file. The information stored in the export file can be used to program a storage device in a more efficient way than programming the actual image file because the export file contains only the information that has to actually be programmed which can help reduce the programming time.

The `exportimage` command is able to export the data in three file formats. The format of the export file is specified via the second command parameter.

A `trim` file stores the contents of all the logical sectors up to and including the last one that contains valid data. The index of the first logical sector stored in the file is always 0 because the file system stores here either format or partitioning information. The logical sectors are stored in consecutive order and without gaps. Typically, exported file is smaller than the image file because the the file system starts allocating storage space from the beginning of the storage device. The exported file may contain invalid logical sectors. The data of these logical sectors is filled with 0s.

A `srec` file stores the contents of all logical sectors that contain valid data in Motorola S-record format. The address stored in the S-record is the byte offset of the data relative to the beginning of the storage device.

A `sblk` file is organized in sector blocks that contain the data of one or more consecutive sectors. Each sector block starts with a 16-byte header and is followed by the sector data. The sector block header stores information about the sector data such as the index of the first sector stored in the sector block and the size of the sector block in bytes. Inside a sector block, the logical sectors are stored in consecutive order and without gaps.

The following table describes the structure of the sector block header. All values are stored in big endian format.

Byte range	Byte count	Description
0-3	4	Index of the first logical sector in the sector block.
4-7	4	Number of bytes in the sector data that follows the sector block header.
8-16	8	Reserved.

Example

```
exportimage C:\Temp\SDCard.bin
```

19.3.2 File and directory related commands

The following sections describe the commands that can be used to operate on the files and directories stored on the image file. The commands described in this section can be executed only after the execution of the `init` command.

19.3.2.1 cd

Description

Changes the current working directory.

Syntax

```
chdir <DirPathOnImage>  
cd    <DirPathOnImage>
```

Parameters

Parameter	Description
DirPathOnImage	Path to new directory to change to.

Additional information

If [DirPathOnImage](#) is set to `..` the command changes to the parent directory. After initialization the current directory is set to the root directory.

Example

In the following sample the working directory is changed to `Test` and then back to the original directory.

```
cd Test  
cd ..
```

19.3.2.2 md

Description

Creates a directory.

Syntax

```
mkdir <DirPathOnImage>  
md    <DirPathOnImage>
```

Parameters

Parameter	Description
DirPathOnImage	Path to directory to be created.

Additional information

This command is able to create any missing directories in the path.

Example

```
md Test\Dir\
```

19.3.2.3 rd

Description

Removes a directory.

Syntax

```
rmdir <DirPathOnImage> [/R]  
rd    <DirPathOnImage> [/R]
```

Parameters

Parameter	Description
DirPathOnImage	Path to directory to be deleted.
/R	Option that causes the command to delete non-empty directories.

Additional information

If the /R option is not specified, then the directory to be deleted must be empty.

Example

```
rd Test
```

19.3.2.4 addfile

Description

Copies a file from the host PC to the image file.

Syntax

```
addfile <FilePathOnHost> [<FilePathOnImage>]  
af      <FilePathOnHost> [<FilePathOnImage>]
```

Parameters

Parameter	Description
FilePathOnHost	Path to the source file on host PC.
FilePathOnImage	Path to destination file on the image.

Additional information

If [FilePathOnImage](#) is not specified then the name of the source file is used.

Example

The following command copies the contents of the `Test.txt` file from host PC to `Dest.txt` file on image.

```
addfile C:\Test.txt Dest.txt
```

The following command copies the contents of `Test.txt` file to the file with the same name of the image.

```
addfile C:\Test.txt
```

19.3.2.5 addfolder

Description

Copies a folder including its subfolders and files from the host PC to the image file.

Syntax

```
addfolder <DirPathOnHost> [<DirPathOnImage>] [/S]
```

Parameters

Parameter	Description
<code>DirPathOnHost</code>	Path to source directory on the host PC.
<code>DirPathOnImage</code>	Path to destination directory on the image.
<code>/S</code>	Option that causes the command to suppress the output of progress information.

Additional information

If `DirPathOnImage` is not specified then the name of the source directory is used.

Example

The following command copies the contents of the `Data` directory on PC to `Dest` directory on the image.

```
addfolder C:\Data Dest
```

The following command copies the contents of the `Data` directory on PC to a directory with the same name on the image.

```
addfolder C:\Data
```

19.3.2.6 type

Description

Shows the contents of a file.

Syntax

```
type <FilePathOnImage>
```

Parameters

Parameter	Description
<code>FilePathOnImage</code>	Path to the file on image to be shown.

Example

The following command line shows the contents of the file `Test.txt` located on the root directory of the image.

```
type Test.txt
```

19.3.2.7 del

Description

Deletes a file.

Syntax

```
del <FilePathOnImage>
```

Parameters

Parameter	Description
<code>FilePathOnImage</code>	Path to the file on image to be deleted.

Example

The following command line deletes the file `Test.txt` located on the root directory of the image.

```
del Test.txt
```

19.3.2.8 dir

Description

Lists the contents of the directory.

Syntax

```
ls [<DirPathOnImage>]  
dir [<DirPathOnImage>]
```

Parameters

Parameter	Description
DirPathOnImage	Path to directory on image to be listed.

Additional information

If [DirPathOnImage](#) is not specified then the command lists the contents of the current working directory.

Example

The following command line shows the contents of the directory `TestDir`.

```
dir file:0:\TestDir  
.  
..  
SubDir  
Test1.txt  
Test2.txt  
(Dir) Attributes: ----  
(Dir) Attributes: ----  
(Dir) Attributes: ----  
Attributes: A--- Size: 30  
Attributes: A--- Size: 31
```

19.3.2.9 ren

Description

Renames a file or directory.

Syntax

```
rename <FilePathOnImage> <NewFileName>  
ren    <FilePathOnImage> <NewFileName>
```

Parameters

Parameter	Description
FilePathOnImage	Path to file or directory that has to be renamed.
NewFileName	New name of the file or directory.

Additional information

If [DirPathOnImage](#) is not specified then the command lists the contents of the current working directory.

Example

The following command line changes the name of `Test.txt` file located in the `Test` directory to `Test2.txt`.

```
ren Test\Test.txt Test2.txt
```

19.3.2.10 move

Description

Moves a file or directory to another location.

Syntax

```
move <SrcFilePathOnImage> <DestFilePathOnImage>  
mv   <SrcFilePathOnImage> <DestFilePathOnImage>
```

Parameters

Parameter	Description
SrcFilePathOnImage	Path to file or directory to be moved.
DestFilePathOnImage	Path to destination file or directory on the image.

Example

The following command line moves the `Test.txt` file located in the `Test` directory to the root directory. The file is renamed to `New.txt`.

```
move Test\Test.txt New.txt
```

19.3.2.11 attr

Description

Shows/changes the file/directory attributes.

Syntax

```
attr <PathOnImage> [<Operation> <Attributes>]
```

Parameters

Parameter	Description
<code>PathOnImage</code>	Path to file or directory.
<code>Operation</code>	Operation to be executed on attributes. Permitted values are: <ul style="list-style-type: none"> • + sets the attributes. • - clears the attributes.
<code>Attributes</code>	The list of attributes to be changed The following attributes are supported: <ul style="list-style-type: none"> • a - archive. • h - hidden. • r - read-only. • s - system.

Example

The following example the clears the archive and read-only attributes of the `Test.txt` file.

```
attr Test.txt -ar
```

19.3.2.12 copy

Description

Copies a file to another location.

Syntax

```
copy <SrcFilePathOnImage> <DestFilePathOnImage>  
cp   <SrcFilePathOnImage> <DestFilePathOnImage>
```

Parameters

Parameter	Description
SrcFilePathOnImage	Path to the file to be copied.
DestFilePathOnImage	Path to destination the file.

Example

The following example copies the contents of the `Test.txt` to the `Test2.txt` file.

```
copy Test.txt Test2.txt
```

19.3.2.13 exportfile

Description

Copies a file from image file to host PC.

Syntax

```
exportfile <FilePathOnImage> <FilePathOnHost>  
ef        <FilePathOnImage> <FilePathOnHost>
```

Parameters

Parameter	Description
<code>FilePathOnImage</code>	Path to the source file on image.
<code>FilePathOnHost</code>	Path to the destination file on PC.

Example

The following command copies the contents of the `Test.txt` file from image to `Dest.txt` file on host PC.

```
exportfile Test.txt C:\Dest.txt
```

19.3.2.14 exportfolder

Description

Copies a directory recursively from image to host PC.

Syntax

```
exportfolder <DirPathOnImage> <DirPathOnHost>
```

Parameters

Parameter	Description
DirPathOnImage	Path to the source directory on image.
DirPathOnHost	Path to the destination directory on PC.

Example

The following command copies the contents of the entire current volume from image to Exported\RootDir directory on host PC.

```
exportfolder \ Exported\RootDir
```

19.3.3 Logical sector related commands

The following sections describe commands that can be used to operate on logical sectors.

19.3.3.1 storesectors

Description

Copies logical sector data from a file on the PC host to image file.

Syntax

```
storesectors <FilePathOnImage> [<StartSector>]
```

Parameters

Parameter	Description
<code>FilePathOnImage</code>	Path to the file on host that contains sector data.
<code>StartSector</code>	Index of the first logical sector to be written.

Additional information

This command is optional. The sector data must be stored sequentially in the file. For example if the sector size is 2048 bytes and the data is stored starting from sector index 100 then the byte at offset 0 in the file stores the first byte of sector 100, the byte at offset 2048 in the file stores the first byte of sector 101 and so on. The size of the file has to be a multiple of sector size. The size of the sector is the size specified as second the argument to `createimage` command.

Example

This example reads sector data from the file `SectorData.bin` and writes it starting from sector index 100.

```
storesectors SectorData.bin 100
```

19.3.3.2 dumpsector

Description

Shows the contents of a logical sector.

Syntax

```
dumpsector <SectorIndex>
ds          <SectorIndex>
```

Parameters

Parameter	Description
SectorIndex	Index of the logical sector to be displayed.

Example

The following command shows the contents of the logical sector 0.

```
dumpsector 0
00000000 34 33 32 31 34 33 32 31 34 33 32 31 34 33 32 31 4321432143214321
00000010 34 33 32 31 34 33 32 31 34 33 32 31 34 33 32 31 4321432143214321
00000020 34 33 32 31 34 33 32 31 34 33 32 31 34 33 32 31 4321432143214321
00000030 0D 0A 34 33 32 31 34 33 32 31 34 33 32 31 34 33 ..43214321432143
00000040 32 31 34 33 32 31 34 33 32 31 34 33 32 31 34 33 2143214321432143
00000050 32 31 34 33 32 31 34 33 32 31 34 33 32 31 34 33 2143214321432143
00000060 32 31 0D 0A 34 33 32 31 34 33 32 31 34 33 32 31 21..432143214321
00000070 34 33 32 31 34 33 32 31 34 33 32 31 34 33 32 31 4321432143214321
00000080 34 33 32 31 34 33 32 31 34 33 32 31 34 33 32 31 4321432143214321
00000090 34 33 32 31 0D 0A 34 33 32 31 34 33 32 31 34 33 4321..4321432143
000000A0 32 31 34 33 32 31 34 33 32 31 34 33 32 31 34 33 2143214321432143
000000B0 32 31 34 33 32 31 34 33 32 31 34 33 32 31 34 33 2143214321432143
000000C0 32 31 34 33 32 31 0D 0A 34 33 32 31 34 33 32 31 214321..43214321
000000D0 34 33 32 31 34 33 32 31 34 33 32 31 34 33 32 31 4321432143214321
000000E0 34 33 32 31 34 33 32 31 34 33 32 31 34 33 32 31 4321432143214321
000000F0 34 33 32 31 34 33 32 31 0D 0A 34 33 32 31 34 33 43214321..432143
00000100 32 31 34 33 32 31 34 33 32 31 34 33 32 31 34 33 2143214321432143
00000110 32 31 34 33 32 31 34 33 32 31 34 33 32 31 34 33 2143214321432143
00000120 32 31 34 33 32 31 34 33 32 31 0D 0A 34 33 32 31 2143214321..4321
00000130 34 33 32 31 34 33 32 31 34 33 32 31 34 33 32 31 4321432143214321
00000140 34 33 32 31 34 33 32 31 34 33 32 31 34 33 32 31 4321432143214321
00000150 34 33 32 31 34 33 32 31 34 33 32 31 0D 0A 34 33 432143214321..43
00000160 32 31 34 33 32 31 34 33 32 31 34 33 32 31 34 33 2143214321432143
00000170 32 31 34 33 32 31 34 33 32 31 34 33 32 31 34 33 2143214321432143
00000180 32 31 34 33 32 31 34 33 32 31 34 33 32 31 0D 0A 21432143214321..
00000190 34 33 32 31 34 33 32 31 34 33 32 31 34 33 32 31 4321432143214321
000001A0 34 33 32 31 34 33 32 31 34 33 32 31 34 33 32 31 4321432143214321
000001B0 34 33 32 31 34 33 32 31 34 33 32 31 34 33 32 31 4321432143214321
000001C0 0D 0A 34 33 32 31 34 33 32 31 34 33 32 31 34 33 ..43214321432143
000001D0 32 31 34 33 32 31 34 33 32 31 34 33 32 31 34 33 2143214321432143
000001E0 32 31 34 33 32 31 34 33 32 31 34 33 32 31 34 33 2143214321432143
000001F0 32 31 0D 0A 34 33 32 31 34 33 32 31 34 33 32 31 21..432143214321
```

19.3.3.3 copysectors

Description

Copies logical sector data to another location.

Syntax

```
copysectors <SrcSector> <DestSector> <NumSectors>  
cs          <SrcSector> <DestSector> <NumSectors>
```

Parameters

Parameter	Description
SrcSector	Index of the first source sector.
DestSector	Index of the first destination sector.
NumSectors	Number of sectors to copy.

Additional information

This command operates only on the `file:0:` volume. The command reports an error if the source and destination sector ranges overlap.

Example

This example copies 10000 logical sectors from sector index 0 to sector index 20000.

```
copysectors 0 20000 10000
```

19.3.4 Volume specific commands

The following sections describe commands that operate on the file system volumes located on the image file.

19.3.4.1 format

Description

High-level formats a volume.

Syntax

```
format [<VolumeName>]
```

Parameters

Parameter	Description
<code>VolumeName</code>	Name of the volume that has to be formatted.

Additional information

If `VolumeName` is not specified then the command formats the current first volume. The current volume can be selected via the `cd` command.

Every volume has to be high-level formatted once when the image file is newly created.

Example

This example demonstrates how to format the volume `file:0`:

```
format
High-level format...OK
```

19.3.4.2 df

Description

Shows the available free space on a volume.

Syntax

```
diskfree [<VolumeName>]  
df      [<VolumeName>]
```

Parameters

Parameter	Description
VolumeName	Name of the volume to be queried.

Additional information

If [VolumeName](#) is not specified than the command calculates the free space of the current volume. The current volume can be selected via the `cd` command.

Example

This example demonstrates how to get the frees space on the first volume.

```
df  
Available free space is 127647744 bytes
```

19.3.4.3 diskinfo

Description

Shows information about a storage device.

Syntax

```
diskinfo [<VolumeName>]  
di      [<VolumeName>]
```

Parameters

Parameter	Description
VolumeName	Name of the volume to be queried.

Additional information

If [VolumeName](#) is not specified then the command returns information about the current volume. The current volume can be selected via the `cd` command.

Example

This example demonstrates how to get information about the volume `file:1:`.

```
diskinfo file:1:  
 127647744 bytes total disk space  
 17719296 bytes available free space  
   8192 bytes per cluster  
 15582 cluster available on volume  
   2163 free cluster available on volume
```

19.3.4.4 getdevinfo

Description

Shows information about a volume.

Syntax

```
getdevinfo [<VolumeName>]
```

Parameters

Parameter	Description
<code>VolumeName</code>	Name of the volume to be queried.

Additional information

If `VolumeName` is not specified then the command returns information about the first volume. The current volume can be selected via the `cd` command.

Example

This example demonstrates how to get information about the storage device used by the first volume.

```
getdevinfo
  62370 available sectors
  2048 bytes per sector
```

19.3.4.5 checkdisk

Description

Checks a volume for errors.

Syntax

```
checkdisk [<VolumeName>]  
chkdsk   [<VolumeName>]
```

Parameters

Parameter	Description
VolumeName	Name of the volume to be checked.

Additional information

If [VolumeName](#) is not specified then the command checks the current volume for errors. The current volume can be selected via the `cd` command.

Example

This example demonstrates how to check the file system structure of the first volume.

```
checkdisk
```

19.3.4.6 creatembr

Description

Writes partition table to master boot record (MBR).

Syntax

```
creatembr [<VolumeName>]  
cm       [<VolumeName>]
```

Parameters

Parameter	Description
VolumeName	Name of the volume to be written.

Additional information

If [VolumeName](#) is not specified then the command writes the MBR to the current volume. The current volume can be selected via the `cd` command.

This command stores the partition table configured via `addpartition` command to the MBR of the specified volume. The command has to be executed after the low-level format and before any high-level format operation. Typically, the partition table is located on `file:0:` volume.

Example

This example stores the MBR to the sector 0 of the `file:0:` volume.

```
creatembr file:0:
```

19.3.4.7 listvolumes

Description

Shows the names of all available volumes.

Syntax

```
listvolumes  
lv
```

Example

Shows the names of the volumes of in a configuration using five volumes.

```
listvolumes  
Available volumes:  
file:0:  
diskpart:0:  
diskpart:1:  
diskpart:2:  
diskpart:3:
```

19.3.4.8 createjournal

Description

Creates the journal file on a volume.

Syntax

```
createjournal [<VolumeName>][<PathToFile>]<FileName>
             <JournalSize> [<SupportFreeSector>]
```

Parameters

Parameter	Description
VolumeName	Name of the volume that stores the journal file.
PathToFile	Path to the journal file.
FileName	Name of the journal file.
JournalSize	Size of the journal file.
SupportFreeSector	Size of the journal file.

Additional information

If [VolumeName](#) is not specified then the command creates the journal on the current volume. The current volume can be selected via the `cd` command. If [PathToFile](#) is not specified then the journal file is created on the root directory of the specified volume. [JournalSize](#) has to be specified in bytes. The value of [SupportFreeSector](#) is passed as third argument to `FS_JOURNAL_CreateEx()`. If not specified [SupportFreeSector](#) is set to 0.

The parameters passed to the `createjournal` command have to match the parameters passed to `FS_JOURNAL_CreateEx()` on the target application.

Example

This example demonstrates how to create a journal file of 128 Kbytes on the current volume.

```
createjournal Journal.dat 131072 1
Create journal file 'Journal.dat'...OK
```

Chapter 20

Porting emFile 2.x to 3.x

This chapter describes the differences between the versions 2.x and 3.x of emFile and the changes required to port an existing application.

20.1 Differences between version 2.x and 3.x

Most of the differences between emFile version 2.x to version 3.x are internal. The API of emFile version 2.x is a subset of the API of version 3.x. Only few functions were completely removed. Refer to section *API differences* on page 1520 for a complete overview of the removed and obsolete functions.

emFile version 3.x has a new driver handling. You can include device drivers and allocate the required memory for it without the need to recompile the entire file system. Refer to *Configuration of emFile* on page 1218 for detailed information about the integration of a driver into emFile. For detailed information about the emFile device drivers, refer to the chapter *Device drivers* on page 389.

Because of these differences, we recommend to start with a new file system project and include your application code, if the start project runs without any problem. Refer to the chapter *Running emFile on target hardware* on page 51 for detailed information about the best way to start to work with emFile version 3.x. The following sections give an overview about the changes introduced in the version 3.x of emFile.

20.2 API differences

Function	Description
Changed functions	
FS_GetFreeSpace()	Number of parameters reduced. Parameter <code>DevIndex</code> removed.
FS_GetTotalSpace()	Number of parameters reduced. Parameter <code>DevIndex</code> removed.
Removed functions	
FS_CloseDir()	No direct replacement. See the note below the table.
FS_DirEnt2Attr()	No direct replacement. See the note below the table.
FS_DirEnt2Name()	No direct replacement. See the note below the table.
FS_DirEnt2Size()	No direct replacement. See the note below the table.
FS_DirEnt2Time()	No direct replacement. See the note below the table.
FS_GetNumFiles()	No direct replacement. See the note below the table.
FS_OpenDir()	No direct replacement. See the note below the table.
FS_ReadDir()	No direct replacement. See the note below the table.
FS_RewindDir()	No direct replacement. See the note below the table.
Obsolete file system extended functions	
FS_IoCtl()	This function should not be used in emFile version 3.x. Alternatively, <code>FS_IsLLFormatted()</code> has to be used instead to check if a low-level format is required and <code>FS_GetDeviceInfo()</code> to get information about the storage device.

Note

The handling of the directories was changed in version 3.x of emFile. Refer to `FS_FindClose()` for an example of the new way of directory handling.

In emFile version 3.x, the header file `FS_Api.h` is renamed to `FS.h`, therefore change the name of the file system header file in your application.

20.3 Configuration differences

The configuration of emFile version 3.x has been simplified compared to emFile version 2.x. emFile version 3.x can be used "out of the box". You can use it without the need for changing any of the compile time flags. All compile time configuration flags are preconfigured with valid values, which matches the requirements of most applications. A lot of the compile time flags of emFile version 2.x were removed and replaced with runtime configuration function.

Removed/replaced configuration macros

In version 3.x removed macros	In version 3.x used macros
File system configuration	
FS_MAXOPEN	--
FS_POSIX_DIR_SUPPORT	--
FS_DIR_MAXOPEN	FS_NUM_DIR_HANDLES
FS_DIRNAME_MAX	--
FS_SUPPORT_BURST	--
FS_DRIVER_ALIGNMENT	--
FAT configuration macros	
FS_FAT_SUPPORT_LFN	Replaced by <code>FS_FAT_SupportLFN()</code> . Refer to <code>FS_FAT_SupportLFN()</code> for more information.

Chapter 21

Porting emFile 3.x to 4.x

This chapter describes the differences between the versions 3.x and 4.x of emFile and the changes required to port an application to the new version.

21.1 Differences between version 3.x and 4.x

Most of the differences between emFile version 3.x and version 4.x are internal. The API of emFile version 3.x is a subset of the version 4.x. There are two differences that require the porting of an application using emFile:

- The API of the hardware layer has been improved.
- The SD/MMC device driver for Atmel MCUs has been removed.

emFile version 4.x has a new hardware layer API. The name of the functions are no longer hard-coded in the source. Instead, the drivers call the functions indirectly via a function table. The hardware layer is specified as an instance of a structure that contains pointers to functions. This gives greater flexibility to the application allowing it to configure different hardware layers at runtime depending on the target hardware it runs on. The emFile configurations that do not require a hardware layer are not affected by this change.

The SD/MMC device driver for Atmel MCUs (`FS_MMC_CM_Driver4Atmel`) has been removed from the version 4.x of emFile. The reason for this change is to eliminate duplicated functionality. The SD/MMC card mode device driver (`FS_MMC_CM_Driver`) supports all the functionality of the SD/MMC device driver for Atmel MCUs and can be used as replacement.

The following sections give detailed information about the changes introduced in the version 4.x of emFile that require changes in the application.

21.2 Hardware layer API differences

The function prototypes of the new hardware layer API of version 4.x are identical to the hardware layer functions used in the version 3.x of emFile. No functions have been added to or removed from the new hardware layer API and no changes are required to the implementation of the existing hardware layer functions. Typically, the following changes are required for porting an application to version 4.x:

- A function table containing pointers to the hardware layer functions has to be declared as a global variable in the file that implements the old hardware layer. The type of the function table depends on the hardware layer used.
- A header file has to be created that declares the function table as external.
- The header file has to be included in the file that defines the `FS_X_AddDevices()` function.
- A call to one of the functions that configure the type of the hardware layer has to be added to `FS_X_AddDevices()`. These functions take as second argument a pointer to the function table.

Alternatively, the steps 1 to 3 can be skipped and a default hardware layer can be used instead. The function table of these hardware layers contain pointers to functions used in the version 3.x of emFile. More information can be found in the following sections that describe the differences for each hardware layer type.

21.2.1 NAND device driver differences

Sample hardware layers using the new API and the corresponding file system configuration files can be found in the `Sample/FS/Driver/NAND` folder of the emFile shipment and are located in the following files:

Hardware layer for parallel NAND flash via memory controller

- `FS_NAND_HW_Template.h`
- `FS_NAND_HW_Template.c`
- `FS_ConfigNAND_Template.c`

Hardware layer for parallel NAND flash via I/O port

- `FS_NAND_HW_TemplatePort.h`
- `FS_NAND_HW_TemplatePort.c`
- `FS_ConfigNAND_TemplatePort.c`

Hardware layer for DataFlash via SPI

- `FS_NAND_HW_DF_Template.h`
- `FS_NAND_HW_DF_Template.c`
- `FS_ConfigNAND_DF_Template.c`

Hardware layer for serial NAND flash via SPI

- `FS_NAND_HW_SPI_Template.h`
- `FS_NAND_HW_SPI_Template.c`
- `FS_ConfigNAND_UNI_SPI_Template.c`

21.2.1.1 Porting without hardware layer modification

The porting of the application to the new hardware layer API can be done without modifying the existing hardware layer. emFile comes with default hardware layers that contain pointers to the hardware layer functions used in the version 3.x of emFile. A call to the function that configures the hardware layer type has to be added to file system configuration and the file that defines the default hardware layer has to be added to the project. The following table shows in which file each default hardware layer is defined. All the files are located in the `Sample/FS/Driver/NAND` folder of the emFile shipment.

Default hardware layer	File name
<code>FS_NAND_HW_Default</code>	<code>FS_NAND_HW_Default.c</code>
<code>FS_NAND_HW_DF_Default</code>	<code>FS_NAND_HW_DF_Default.c</code>
<code>FS_NAND_HW_SPI_Default</code>	<code>FS_NAND_HW_SPI_Default.c</code>

The table below lists the default hardware layer required by each physical layer:

Physical layer	Default hardware layer
<code>FS_NAND_PHY_x</code>	<code>FS_NAND_HW_Default</code>
<code>FS_NAND_PHY_x8</code>	<code>FS_NAND_HW_Default</code>
<code>FS_NAND_PHY_512x8</code>	<code>FS_NAND_HW_Default</code>
<code>FS_NAND_PHY_2048x8</code>	<code>FS_NAND_HW_Default</code>
<code>FS_NAND_PHY_2048x16</code>	<code>FS_NAND_HW_Default</code>
<code>FS_NAND_PHY_4096x8</code>	<code>FS_NAND_HW_Default</code>
<code>FS_NAND_PHY_ONFI</code>	<code>FS_NAND_HW_Default</code>
<code>FS_NAND_PHY_DataFlash</code>	<code>FS_NAND_HW_DF_Default</code>
<code>FS_NAND_PHY_SPI</code>	<code>FS_NAND_HW_SPI_Default</code>

For more information about the functions of the physical layers refer to *NAND physical layer* on page 590.

Example

The following example shows how to port an existing configuration using the SLC1 NAND device driver. Two changes are required:

- The function call marked with the comment "Add this line" in the code snippet below has to be added to the existing emFile configuration.
- The file `Sample/FS/Driver/NAND/FS_NAND_HW_Default.c` that defines the `FS_NAND_HW_Default` hardware layer has to be added to the project.

```
void FS_X_AddDevices(void) {
    FS_AssignMemory(&_aMemBlock[0], sizeof(_aMemBlock));
    //
    // The next line is optional.
    //
    // FS_SetMaxSectorSize(2048);
    //
    // Add and configure the driver.
    //
    FS_AddDevice(&FS_NAND_Driver);
    FS_NAND_SetPhyType(0, &FS_NAND_PHY_2048x8);
    FS_NAND_2048x8_SetHWType(0, &FS_NAND_HW_Default); // Add this line.
    //
    // Enable the file buffer to increase the performance
    // when reading/writing a small number of bytes.
    //
    FS_ConfigFileBufferDefault(512, FS_FILE_BUFFER_WRITE);
}
```

21.2.1.2 Replacement functions

The following table lists the replacement functions of the hardware layer for parallel NAND flash.

Old function	Member of <code>FS_NAND_HW_TYPE</code> structure
<code>FS_NAND_HW_X_Init_x8()</code>	<code>(*pfInit_x8)()</code>
<code>FS_NAND_HW_X_Init_x16()</code>	<code>(*pfInit_x16)()</code>
<code>FS_NAND_HW_X_DisableCE()</code>	<code>(*pfDisableCE)()</code>
<code>FS_NAND_HW_X_EnableCE()</code>	<code>(*pfEnableCE)()</code>
<code>FS_NAND_HW_X_SetAddrMode()</code>	<code>(*pfSetAddrMode)()</code>
<code>FS_NAND_HW_X_SetCmdMode()</code>	<code>(*pfSetCmdMode)()</code>
<code>FS_NAND_HW_X_SetDataMode()</code>	<code>(*pfSetDataMode)()</code>
<code>FS_NAND_HW_X_WaitWhileBusy()</code>	<code>(*pfWaitWhileBusy)()</code>
<code>FS_NAND_HW_X_Read_x8()</code>	<code>(*pfRead_x8)()</code>
<code>FS_NAND_HW_X_Write_x8()</code>	<code>(*pfWrite_x8)()</code>
<code>FS_NAND_HW_X_Read_x16()</code>	<code>(*pfRead_x16)()</code>
<code>FS_NAND_HW_X_Write_x16()</code>	<code>(*pfWrite_x16)()</code>

The following table lists the replacement functions of the hardware layer for DataFlash.

Old function	Member of <code>FS_NAND_HW_TYPE_DF</code> structure
<code>FS_DF_HW_X_Init()</code>	<code>(*pfInit)()</code>
<code>FS_DF_HW_X_EnableCS()</code>	<code>(*pfEnableCS)()</code>
<code>FS_DF_HW_X_DisableCS()</code>	<code>(*pfDisableCS)()</code>
<code>FS_DF_HW_X_Read()</code>	<code>(*pfRead)()</code>
<code>FS_DF_HW_X_Write()</code>	<code>(*pfWrite)()</code>

The following table lists the replacement functions of the hardware layer for serial NAND flash.

Old function	Member of FS_NAND_HW_TYPE_SPI structure
FS_NAND_HW_SPI_X_Init()	(*pfInit)()
FS_NAND_HW_SPI_X_DisableCS()	(*pfDisableCS)()
FS_NAND_HW_SPI_X_EnableCS()	(*pfEnableCS)()
FS_NAND_HW_SPI_X_Delay()	(*pfDelay)()
FS_NAND_HW_SPI_X_Read()	(*pfRead)()
FS_NAND_HW_SPI_X_Write()	(*pfWrite)()

21.2.2 NOR device driver differences

Sample hardware layers using the new API and the corresponding file system configurations can be found in the `Sample/FS/Driver/NOR` folder of the emFile shipment and are located in the following files:

Hardware layer for serial NOR flash

- `FS_NOR_HW_SPI_Template.h`
- `FS_NOR_HW_SPI_Template.c`
- `FS_ConfigNOR_SPI_Template.c`

Hardware layer for QSPI NOR flash

- `FS_NOR_HW_SPIFI_Template.h`
- `FS_NOR_HW_SPIFI_Template.c`
- `FS_ConfigNOR_BM_SPIFI_Template.c`

21.2.2.1 Porting without hardware layer modification

The porting of the application to the new hardware layer API can be done without modifying the existing hardware layer. emFile comes with default hardware layers that contain pointers to the hardware layer functions used in the version 3.x of emFile. A call to the function that sets the hardware layer type has to be added to file system configuration and the file that defines the default hardware layer has to be added to the project. The table below shows in which file each default hardware layer is defined. The files are located in the `Sample/FS/Driver/NOR` folder of the emFile shipment:

Default hardware layer	File name
<code>FS_NOR_HW_ST_M25_Default</code>	<code>FS_NOR_HW_ST_M25_Default.c</code>
<code>FS_NOR_HW_SFDP_Default</code>	<code>FS_NOR_HW_SFDP_Default.c</code>

The table below lists the default hardware layer required by each physical layer:

Physical layer	Default hardware layer
<code>FS_NOR_PHY_ST_M25</code>	<code>FS_NOR_HW_ST_M25_Default</code>
<code>FS_NOR_PHY_SFDP</code>	<code>FS_NOR_HW_SFDP_Default</code>

For more information about the functions of the physical layers refer to *NOR physical layer* on page 840.

Example

This example show how to port an existing configuration for a serial NOR flash. The function call marked with the comment "Add this line" to be added to existing configuration. No other changes of file system configuration are required. Additionally, the file `Sample/FS/Driver/NOR/FS_NOR_HW_ST_M25_Default.c` that defines the `FS_NOR_HW_ST_M25_Default` hardware layer has to be added to the project.

```
void FS_X_AddDevices(void) {
    FS_AssignMemory(&_aMemBlock[0], sizeof(_aMemBlock));
    //
    // Add and configure the driver.
    //
    FS_AddDevice(&FS_NOR_Driver);
    FS_NOR_SetPhyType(0, &FS_NOR_PHY_ST_M25);
    FS_NOR_SPI_SetHWType(0, &FS_NOR_HW_ST_M25_Default); // Add this line.
    FS_NOR_Configure(0, FLASH0_BASE_ADDR, FLASH0_START_ADDR, FLASH0_SIZE);
    //
    // Enable the file buffer to increase the performance
    // when reading/writing a small number of bytes.
    //
    FS_ConfigFileBufferDefault(512, FS_FILE_BUFFER_WRITE);
}
```



```
}

```

21.2.2.2 Replacement functions

The following table lists the replacement functions of the SPI hardware layer.

Old function	Member of the <code>FS_NOR_HW_TYPE_SPI</code> structure
<code>FS_NOR_SPI_HW_X_Init()</code>	<code>(*pfInit)()</code>
<code>FS_NOR_SPI_HW_X_EnableCS()</code>	<code>(*pfEnableCS)()</code>
<code>FS_NOR_SPI_HW_X_DisableCS()</code>	<code>(*pfDisableCS)()</code>
<code>FS_NOR_SPI_HW_X_Read()</code>	<code>(*pfRead)()</code>
<code>FS_NOR_SPI_HW_X_Write()</code>	<code>(*pfWrite)()</code>
<code>FS_NOR_SPI_HW_X_Read_x2()</code>	<code>(*pfRead_x2)()</code>
<code>FS_NOR_SPI_HW_X_Write_x2()</code>	<code>(*pfWrite_x2)()</code>
<code>FS_NOR_SPI_HW_X_Read_x4()</code>	<code>(*pfRead_x4)()</code>
<code>FS_NOR_SPI_HW_X_Write_x4()</code>	<code>(*pfWrite_x4)()</code>

Note

The `..._x2` and `..._x4` functions have to be defined only when the `FS_NOR_PHY_SFDP` physical layer configured and the hardware supports dual and quad SPI data transfer modes.

21.2.3 MMC/SD SPI device driver differences

Sample hardware layers using the new API and the corresponding file system configurations can be found in the `Sample/FS/Driver/MMC_SPI` folder of the emFile shipment and are located in the following files:

Hardware layer for SD card via SPI

- `FS_MMC_HW_SPI_Template.h`
- `FS_MMC_HW_SPI_Template.c`
- `FS_ConfigMMC_SPI_Template.c`

Hardware layer for SD card via I/O port

- `FS_MMC_HW_SPI_TemplatePort.h`
- `FS_MMC_HW_SPI_TemplatePort.c`
- `FS_ConfigMMC_SPI_TemplatePort.c`

21.2.3.1 Porting without hardware layer modification

It is possible to port an existing application to the new hardware layer API without modifying the existing hardware layer. emFile comes with a default hardware layer that contains pointers to the hardware layer functions used in the version 3.x of emFile. A call to the function `FS_MMC_SetHWType()` has to be added to file system configuration and the file that defines the default hardware layer (`FS_MMC_HW_SPI_Default.c`) has to be added to the project. The file is located in the `Sample/FS/Driver/MMC_SPI` folder of the emFile shipment.

Example

This example shows how to modify an existing emFile configuration to work with the new hardware layer API. The function call marked with the comment "Add this line." has to be added to existing configuration. No other changes to file system configuration are required. In addition, the file `Sample/FS/Driver/MMC_SPI/FS_MMC_HW_SPI_Default.c` that defines the `FS_MMC_HW_SPI_Default` hardware layer has to be added to the project.

```
void FS_X_AddDevices(void) {
    FS_AssignMemory(&aMemBlock[0], sizeof(_aMemBlock));
    //
    // Add and configure the driver.
    //
    FS_AddDevice(&FS_MMC_SPI_Driver);
    FS_MMC_SetHWType(0, &FS_MMC_HW_SPI_Default); // Add this line.
    // FS_MMC_ActivateCRC(); // Uncommenting this line will activate
    // the CRC calculation of the MMC/SD SPI driver.
    //
    // Enable the file buffer to increase the performance
    // when reading/writing a small number of bytes.
    //
    FS_ConfigFileBufferDefault(512, FS_FILE_BUFFER_WRITE);
}
```

21.2.3.2 Replacement functions

The following table lists the replacement functions of the SPI hardware layer.

Old function	Member of <code>FS_MMC_HW_TYPE_SPI</code> structure
<code>FS_MMC_HW_X_EnableCS()</code>	<code>(*pfEnableCS)()</code>
<code>FS_MMC_HW_X_DisableCS()</code>	<code>(*pfDisableCS)()</code>
<code>FS_MMC_HW_X_IsPresent()</code>	<code>(*pfIsPresent)()</code>
<code>FS_MMC_HW_X_IsWriteProtected()</code>	<code>(*pfIsWriteProtected)()</code>
<code>FS_MMC_HW_X_SetMaxSpeed()</code>	<code>(*pfSetMaxSpeed)()</code>

Old function	Member of <code>FS_MMC_HW_TYPE_SPI</code> structure
<code>FS_MMC_HW_X_SetVoltage()</code>	<code>(*pfSetVoltage)()</code>
<code>FS_MMC_HW_X_Read()</code>	<code>(*pfRead)()</code>
<code>FS_MMC_HW_X_Write()</code>	<code>(*pfWrite)()</code>
<code>FS_MMC_HW_X_ReadEx()</code>	<code>(*pfReadEx)()</code>
<code>FS_MMC_HW_X_WriteEx()</code>	<code>(*pfWriteEx)()</code>
<code>FS_MMC_HW_X_Lock()</code>	<code>(*pfLock)()</code>
<code>FS_MMC_HW_X_Unlock()</code>	<code>(*pfUnlock)()</code>

Note

The locking functions have to be implemented only when the MMC / SD SPI device driver is compiled with the `FS_MMC_SUPPORT_LOCKING` define set to 1.

21.2.4 MMC/SD card mode device driver differences

Sample hardware layers using the new API and the corresponding file system configurations are available in the `Sample/FS/Driver/MMC_CM` folder of the emFile shipment and are located in the following files:

- `FS_MMC_HW_CM_Template.h`
- `FS_MMC_HW_CM_Template.c`
- `FS_ConfigMMC_CardModeTemplate.c`

21.2.4.1 Porting without hardware layer modification

It is possible to port the application to the new hardware layer API without modifying the existing hardware layer. emFile comes with a default hardware layer that contains pointers to the hardware layer functions used in the version 3.x of emFile. A call to the function `FS_MMC_CM_SetHWType()` has to be added to file system configuration and the file that defines the default hardware layer (`FS_MMC_HW_CM_Default.c`) has to be added to the project. The file is located in the `Sample/FS/Driver/MMC_CM` folder of the emFile shipment.

Example

This example shows the modifications that have to be done to an existing application. The function call marked with the comment "Add this line." has to be added to existing configuration. No other changes of file system configuration are required. Additionally, the file `Sample/FS/Driver/MMC_CM/FS_MMC_HW_CM_Default.c` that defines the `FS_MMC_HW_CM_Default` hardware layer has to be added to the project.

```
void FS_X_AddDevices(void) {
    FS_AssignMemory(&_aMemBlock[0], sizeof(_aMemBlock));
    //
    // Add and configure the driver.
    //
    FS_AddDevice(&FS_MMC_CM_Driver);
    FS_MMC_CM_Allow4bitMode(0, 1);
    FS_MMC_CM_SetHWType(0, &FS_MMC_HW_CM_Default); // Add this line.
    //
    // Configure the file system for fast write operations.
    //
    FS_ConfigFileBufferDefault(512, FS_FILE_BUFFER_WRITE);
    FS_SetFileWriteMode(FS_WRITEMODE_FAST);
}
```

21.2.4.2 Replacement functions

The following table lists the replacement functions of the SD / MMC card mode hardware layer.

Old function	Member of <code>FS_MMC_HW_TYPE_CM</code> structure
<code>FS_MMC_HW_X_InitHW()</code>	<code>(*pfInitHW)()</code>
<code>FS_MMC_HW_X_Delay()</code>	<code>(*pfDelay)()</code>
<code>FS_MMC_HW_X_IsPresent()</code>	<code>(*pfIsWriteProtected)()</code>
<code>FS_MMC_HW_X_IsWriteProtected()</code>	<code>(*pfIsPresent)()</code>
<code>FS_MMC_HW_X_SetMaxSpeed()</code>	<code>(*pfSetMaxSpeed)()</code>
<code>FS_MMC_HW_X_SetResponseTimeout()</code>	<code>(*pfSetResponseTimeout)()</code>
<code>FS_MMC_HW_X_SetReadDataTimeout()</code>	<code>(*pfSetReadDataTimeout)()</code>
<code>FS_MMC_HW_X_SendCmd()</code>	<code>(*pfSendCmd)()</code>
<code>FS_MMC_HW_X_GetResponse()</code>	<code>(*pfGetResponse)()</code>

Old function	Member of FS_MMC_HW_TYPE_CM structure
FS_MMC_HW_X_ReadData()	(*pfReadData)()
FS_MMC_HW_X_WriteData()	(*pfWriteData)()
FS_MMC_HW_X_SetDataPointer()	(*pfSetDataPointer)()
FS_MMC_HW_X_SetHWBlockLen()	(*pfSetHWBlockLen)()
FS_MMC_HW_X_SetHWNumBlocks()	(*pfSetHWNumBlocks)()
FS_MMC_HW_X_GetMaxReadBurst()	(*pfGetMaxReadBurst)()
FS_MMC_HW_X_GetMaxWriteBurst()	(*pfGetMaxWriteBurst)()

21.2.5 CompactFlash / IDE device driver differences

Sample hardware layers using the new API and the corresponding file system configurations can be found in the `Sample/FS/Driver/IDE` folder of the emFile shipment in the following files:

Hardware layer for memory map mode

- `FS_IDE_HW_TemplateMemMapped16bit.h`
- `FS_IDE_HW_TemplateMemMapped16Bit.c`
- `FS_ConfigIDE_TemplateMemMapped16Bit.c`

Hardware layer for true IDE mode

- `FS_IDE_HW_TemplateTrueIDE.h`
- `FS_IDE_HW_TemplateTrueIDE.c`
- `FS_ConfigIDE_TemplateTrueIDE.c`

21.2.5.1 Porting without hardware layer modification

It is possible to port the application to the new hardware layer API without modifying the existing hardware layer. emFile comes with a default hardware layer that contains pointers to the hardware layer functions used in the version 3.x of emFile. A call to the function `FS_IDE_SetHWType()` has to be added to file system configuration and the file that defines the default hardware layer (`FS_IDE_HW_Default.c`) has to be added to the project. The file is located in the `Sample/FS/Driver/IDE` folder of the emFile shipment.

Example

This example shows the modifications that have to be done to an existing application. The function call marked mark with the comment "Add this line." has to be added to existing configuration. No other changes of file system configuration are required. In addition, the file `Sample/FS/Driver/IDE/FS_IDE_HW_Default.c` which defines the `FS_IDE_HW_Default` hardware layer has to be added to the project.

```
void FS_X_AddDevices(void) {
    FS_AssignMemory(&aMemBlock[0], sizeof(_aMemBlock));
    FS_AddDevice(&FS_IDE_Driver);
    FS_IDE_SetHWType(0, &FS_IDE_HW_Default);    // Add this line.
    //
    // Enable the file buffer to increase the performance
    // when reading/writing a small number of bytes.
    //
    FS_ConfigFileBufferDefault(512, FS_FILE_BUFFER_WRITE);
}
```

21.2.5.2 Replacement functions

The following table lists the replacement functions of the hardware layer.

Old function	Member of <code>FS_IDE_HW_TYPE</code> structure
<code>FS_IDE_HW_Reset()</code>	<code>(*pfReset)()</code>
<code>FS_IDE_HW_IsPresent()</code>	<code>(*pfIsPresent)()</code>
<code>FS_IDE_HW_Delay400ns()</code>	<code>(*pfDelay400ns)()</code>
<code>FS_IDE_HW_ReadReg()</code>	<code>(*pfReadReg)()</code>
<code>FS_IDE_HW_WriteReg()</code>	<code>(*pfWriteReg)()</code>
<code>FS_IDE_HW_ReadData()</code>	<code>(*pfReadData)()</code>
<code>FS_IDE_HW_WriteData()</code>	<code>(*pfWriteData)()</code>

21.2.6 MMC / SD device driver for ATMEL MCUs

The MMC / SD device driver for ATMEL microcontrollers (`FS_MMC_CM_Driver4Atmel`) is no longer available in the version 4.x of emFile. The MMC/SD card mode device driver (`FS_MM-C_CM_Driver`) provides the same functionality and can be used as replacement. Changes are required both to emFile configuration and to hardware layer in order to port an existing application to the version 4.x of emFile.

21.2.6.1 Configuration changes

The MMC / SD device driver for ATMEL MCUs has to be replaced in the `FS_X_AddDevices()` function by the MMC/SD card mode device driver. In addition, the hardware layer has to be explicitly configured.

Example

This example shows what changes have to be done to emFile configuration. The function calls that marked with the comment "Remove this line." have to be removed from the file system configuration. The function calls that have to be added are marked with the comment "Add this line."

```
void FS_X_AddDevices(void) {
    FS_AssignMemory(&_aMemBlock[0], sizeof(_aMemBlock));
    FS_AddDevice(&FS_MMC_CM_Driver4Atmel);           // Remove this line.
    FS_AddDevice(&FS_MMC_CM_Driver);                // Add this line.
    FS_MMC_CM-Allow4bitMode(0, 1);                  // Add this line.
    FS_MMC_CM_SetHWType(0, &FS_MMC_CM_HW_Default); // Add this line.
}
```

21.2.6.2 Hardware layer changes

The hardware layer APIs of the MMC / SD device driver for ATMEL MCUS and that of the MMC / SD card mode device driver are different. A new hardware layer has to be implemented for the MMC/SD card mode device driver to port an existing application. For more information about the functions of the hardware layer for MMC / SD card mode device driver refer to *Hardware layer* on page 38. Sample implementations for ATMEL AT91SAM9x MCU can be found in the `Sample/FS/Driver/MMC_CM` folder of the emFile shipment.

The table below lists the functions of the hardware layer for the MMC / SD device driver for ATMEL MCUS together with their possible replacement functions.

Old function	Possible replacement
<code>FS_MCI_HW_EnableClock()</code>	The clock to MCI host should be enabled in the <code>(*pfInitHW)()</code> function.
<code>FS_MCI_HW_EnableISR()</code>	The interrupt of MCI host should be enabled in the <code>(*pfInitHW)()</code> function.
<code>FS_MCI_HW_GetMClk()</code>	The information returned by this function is not required anymore.
<code>FS_MCI_HW_GetMCIInfo()</code>	The information returned by this function is not required anymore.
<code>FS_MCI_HW_Init()</code>	<code>(*pfInitHW)()</code>
<code>FS_MCI_HW_IsCardPresent()</code>	<code>(*pfIsPresent)()</code>
<code>FS_MCI_HW_IsCardWriteProtected()</code>	<code>(*pfIsWriteProtected)()</code>
<code>FS_MCI_HW_GetTransferMem()</code>	Non-cached memory should be allocated via a dedicated BSP function.

Chapter 22

Porting emFile 4.x to 5.x

This chapter describes the differences between the versions 4.x and 5.x of emFile and the changes required to port an existing application.

22.1 Differences between version 4.x and 5.x

Most of the differences between emFile version 4.x to version 5.x are internal. The API of emFile version 4.x is a subset of the version 5.x. There are two differences that require the porting of an application using emFile:

- The prototypes of the optional API functions are conditionally compiled.
- Some header and source files were removed or renamed.

22.2 Function prototype differences

emFile uses configuration defines to enable or disable different optional features of the file system at compile time. Typically, the optional features come with API functions that can be called by an application to make use of that optional feature. In older emFile versions these API functions performed no operation or unnecessarily allocated resources when the feature was disabled. The version 5.x changes this in that it defines the body and the prototype of these API functions only when the feature is enabled.

As a result of these changes it is possible that errors are reported when building an application that calls an API function of an optional feature that is not enabled at compile time. The solution to this problem is to enclose the calls to these API functions with `#if/#endif` processor commands that make sure the function is called only when the optional feature is enabled.

For example if the same application is expected to be compiled to make use of the memory allocator provided by emFile as well as of the memory allocation functions of the C library then the emFile configuration functions have to be called such in the following example:

```
#include <FS.h>
#include <stdlib.h>

#define ALLOC_SIZE      0x4000      // Size defined in bytes

#if (FS_SUPPORT_EXT_MEM_MANAGER == 0)
    static U32 _aMemBlock[ALLOC_SIZE / 4]; // Memory pool used for
                                           // semi-dynamic allocation.
#endif

/*****
 *
 *      FS_X_AddDevices
 *
 *      Function description
 *      This function is called by the FS during FS_Init().
 */
void FS_X_AddDevices(void) {
    //
    // Give the file system memory to work with.
    //
    #if (FS_SUPPORT_EXT_MEM_MANAGER == 0)
        FS_AssignMemory(_aMemBlock, sizeof(_aMemBlock));
    #else
        FS_SetMemHandler((FS_MEM_ALLOC_CALLBACK *)malloc, free);
    #endif // FS_SUPPORT_EXT_MEM_MANAGER == 0

    //
    // Additional file system configuration...
    //
}
```

The following table lists all the prototypes of all optional API functions together with the name and the value of the configuration define that enables the optional feature. Note that the table contains all the function prototypes that are conditionally compiled including the function prototypes that were conditionally compiled in older emFile versions.

Function	Condition
FS_ConfigEOFErrorSuppression()	FS_SUPPRESS_EOF_ERROR \neq 0
FS_SetVolumeAlias()	FS_MAX_LEN_VOLUME_ALIAS > 0
FS_DeInit()	FS_SUPPORT_DEINIT \neq 0
FS_AddOnExitHandler()	FS_SUPPORT_DEINIT \neq 0
FS_AssignMemory()	FS_SUPPORT_EXT_MEM_MANAGER = 0
FS_SetMemHandler()	FS_SUPPORT_EXT_MEM_MANAGER \neq 0
FS_ConfigPOSIXSupport()	FS_SUPPORT_POSIX \neq 0
FS_ConfigWriteVerification()	FS_VERIFY_WRITE \neq 0

Function	Condition
FS_JOURNAL_Begin()	FS_SUPPORT_JOURNAL ≠ 0
FS_JOURNAL_Create()	FS_SUPPORT_JOURNAL ≠ 0
FS_JOURNAL_CreateEx()	FS_SUPPORT_JOURNAL ≠ 0
FS_JOURNAL_Disable()	FS_SUPPORT_JOURNAL ≠ 0
FS_JOURNAL_Enable()	FS_SUPPORT_JOURNAL ≠ 0
FS_JOURNAL_End()	FS_SUPPORT_JOURNAL ≠ 0
FS_JOURNAL_GetInfo()	FS_SUPPORT_JOURNAL ≠ 0
FS_JOURNAL_GetOpenCnt()	FS_SUPPORT_JOURNAL ≠ 0
FS_JOURNAL_GetStatCounters()	FS_SUPPORT_JOURNAL ≠ 0
FS_JOURNAL_Invalidate()	FS_SUPPORT_JOURNAL ≠ 0
FS_JOURNAL_IsEnabled()	FS_SUPPORT_JOURNAL ≠ 0
FS_JOURNAL_IsPresent()	FS_SUPPORT_JOURNAL ≠ 0
FS_JOURNAL_ResetStatCounters()	FS_SUPPORT_JOURNAL ≠ 0
FS_JOURNAL_SetFileName()	FS_SUPPORT_JOURNAL ≠ 0
FS_JOURNAL_SetOnOverflowExCallback()	FS_SUPPORT_JOURNAL ≠ 0
FS_JOURNAL_SetOnOverflowCallback()	FS_SUPPORT_JOURNAL ≠ 0
FS_FAT_FormatSD()	FS_SUPPORT_FAT ≠ 0
FS_FAT_GrowRootDir()	FS_SUPPORT_FAT ≠ 0
FS_FAT_SupportLFN()	FS_SUPPORT_FAT ≠ 0
FS_FAT_DisableLFN()	FS_SUPPORT_FAT ≠ 0
FS_FAT_SetLFNConverter()	FS_SUPPORT_FAT ≠ 0 && FS_SUPPORT_FILE_NAME_ENCODING ≠ 0
FS_FAT_ConfigFSInfoSectorUse()	FS_SUPPORT_FAT ≠ 0 && FS_FAT_USE_FSINFO_SECTOR ≠ 0
FS_FAT_ConfigFATCopyMaintenance()	FS_SUPPORT_FAT ≠ 0 && FS_MAINTAIN_FAT_COPY ≠ 0
FS_FAT_ConfigROFileMovePermission()	FS_SUPPORT_FAT ≠ 0 && FS_FAT_PERMIT_RO_FILE_MOVE ≠ 0
FS_FAT_ConfigDirtyFlagUpdate()	FS_SUPPORT_FAT ≠ 0 && FS_FAT_UPDATE_DIRTY_FLAG ≠ 0
FS_EFS_ConfigStatusSectorSupport()	FS_SUPPORT_EFS ≠ 0 && FS_EFS_SUPPORT_STATUS_SECTOR ≠ 0
FS_EFS_ConfigCaseSensitivity()	FS_SUPPORT_EFS ≠ 0 && FS_EFS_CASE_SENSITIVE ≠ 0
FS_EFS_SetFileNameConverter()	FS_SUPPORT_EFS ≠ 0 && FS_SUPPORT_FILE_NAME_ENCODING ≠ 0
FS_ConfigFileBufferDefault()	FS_SUPPORT_FILE_BUFFER ≠ 0
FS_SetFileBufferFlags()	FS_SUPPORT_FILE_BUFFER ≠ 0
FS_SetFileBufferFlagsEx()	FS_SUPPORT_FILE_BUFFER ≠ 0
FS_SetFileBuffer()	FS_SUPPORT_FILE_BUFFER ≠ 0
FS_SetBusyLEDCallback()	FS_SUPPORT_BUSY_LED ≠ 0
FS_SetMemCheckCallback()	FS_SUPPORT_CHECK_MEMORY ≠ 0
FS_STORAGE_DeInit()	FS_SUPPORT_DEINIT ≠ 0
FS_STORAGE_GetCounters()	FS_STORAGE_ENABLE_STAT_COUNTERS ≠ 0
FS_STORAGE_ResetCounters()	FS_STORAGE_ENABLE_STAT_COUNTERS ≠ 0

Function	Condition
FS_STORAGE_SetOnDeviceActivityCallback()	FS_STORAGE_SUPPORT_DEVICE_ACTIVITY \neq 0
FS_AssignCache()	FS_SUPPORT_CACHE \neq 0
FS_CACHE_Clean()	FS_SUPPORT_CACHE \neq 0
FS_CACHE_Command()	FS_SUPPORT_CACHE \neq 0
FS_CACHE_SetMode()	FS_SUPPORT_CACHE \neq 0
FS_CACHE_SetQuota()	FS_SUPPORT_CACHE \neq 0
FS_CACHE_SetAssocLevel()	FS_SUPPORT_CACHE \neq 0
FS_CACHE_GetNumSectors()	FS_SUPPORT_CACHE \neq 0
FS_CACHE_Invalidate()	FS_SUPPORT_CACHE \neq 0
FS_SetFSType()	FS_SUPPORT_MULTIPLE_FS \neq 0
FS_GetFSType()	FS_SUPPORT_MULTIPLE_FS \neq 0
FS_Free()	FS_SUPPORT_DEINIT \neq 0
FS_Lock()	FS_OS_LOCKING = FS_OS_LOCKING_API
FS_Unlock()	FS_OS_LOCKING = FS_OS_LOCKING_API
FS_LockVolume()	FS_OS_LOCKING = FS_OS_LOCKING_DRIVER
FS_UnlockVolume()	FS_OS_LOCKING = FS_OS_LOCKING_DRIVER
FS_SYSVIEW_Init()	FS_SUPPORT_PROFILE \neq 0
FS_AddErrorFilter()	FS_DEBUG_LEVEL \geq FS_DEBUG_LEVEL_LOG_ERRORS
FS_SetErrorFilter()	FS_DEBUG_LEVEL \geq FS_DEBUG_LEVEL_LOG_ERRORS
FS_GetErrorFilter()	FS_DEBUG_LEVEL \geq FS_DEBUG_LEVEL_LOG_ERRORS
FS_AddWarnFilter()	FS_DEBUG_LEVEL \geq FS_DEBUG_LEVEL_LOG_WARNINGS
FS_SetWarnFilter()	FS_DEBUG_LEVEL \geq FS_DEBUG_LEVEL_LOG_WARNINGS
FS_GetWarnFilter()	FS_DEBUG_LEVEL \geq FS_DEBUG_LEVEL_LOG_WARNINGS
FS_AddLogFilter()	FS_DEBUG_LEVEL \geq FS_DEBUG_LEVEL_LOG_ALL
FS_SetLogFilter()	FS_DEBUG_LEVEL \geq FS_DEBUG_LEVEL_LOG_ALL
FS_GetLogFilter()	FS_DEBUG_LEVEL \geq FS_DEBUG_LEVEL_LOG_ALL
FS_NOR_GetStatCounters()	FS_NOR_ENABLE_STATS \neq 0
FS_NOR_ResetStatCounters()	FS_NOR_ENABLE_STATS \neq 0
FS_NOR_SetBlankSectorSkip()	FS_NOR_SKIP_BLANK_SECTORS \neq 0
FS_NOR_SetDeviceLineSize()	FS_NOR_SUPPORT_VARIABLE_LINE_SIZE \neq 0
FS_NOR_SetDeviceRewriteSupport()	FS_NOR_SUPPORT_VARIABLE_LINE_SIZE \neq 0
FS_NOR_SetDirtyCheckOptimization()	FS_NOR_OPTIMIZE_DIRTY_CHECK \neq 0
FS_NOR_SetEraseVerification()	FS_NOR_VERIFY_ERASE \neq 0
FS_NOR_SetWriteVerification()	FS_NOR_VERIFY_WRITE \neq 0

Function	Condition
FS_NOR_BM_DisableCRC()	FS_NOR_SUPPORT_CRC ≠ 0
FS_NOR_BM_EnableCRC()	FS_NOR_SUPPORT_CRC ≠ 0
FS_NOR_BM_GetStatCounters()	FS_NOR_ENABLE_STATS ≠ 0
FS_NOR_BM_IsCRCEnabled()	FS_NOR_SUPPORT_CRC ≠ 0
FS_NOR_BM_ResetStatCounters()	FS_NOR_ENABLE_STATS ≠ 0
FS_NOR_BM_SetBlankSectorSkip()	FS_NOR_SKIP_BLANK_SECTORS ≠ 0
FS_NOR_BM_SetByteOrderBE()	FS_NOR_SUPPORT_VARIABLE_BYTE_ORDER ≠ 0
FS_NOR_BM_SetByteOrderLE()	FS_NOR_SUPPORT_VARIABLE_BYTE_ORDER ≠ 0
FS_NOR_BM_SetCRCHook()	FS_NOR_SUPPORT_CRC ≠ 0
FS_NOR_BM_SetDeviceLineSize()	FS_NOR_SUPPORT_VARIABLE_LINE_SIZE ≠ 0
FS_NOR_BM_SetDeviceRewriteSupport()	FS_NOR_SUPPORT_VARIABLE_LINE_SIZE ≠ 0
FS_NOR_BM_SetEraseVerification()	FS_NOR_VERIFY_ERASE ≠ 0
FS_NOR_BM_SetFailSafeErase()	FS_NOR_SUPPORT_FAIL_SAFE_ERASE ≠ 0
FS_NOR_BM_SetWriteVerification()	FS_NOR_VERIFY_WRITE ≠ 0
FS_NOR_SPI_AddDevice()	FS_NOR_MAX_NUM_DEVICES ≠ 0
FS_MMC_GetStatCounters()	FS_MMC_ENABLE_STATS ≠ 0
FS_MMC_ResetStatCounters()	FS_MMC_ENABLE_STATS ≠ 0
FS_MMC_CM_AllowPowerSaveMode()	FS_MMC_SUPPORT_POWER_SAVE ≠ 0
FS_MMC_CM_EnterPowerSaveMode()	FS_MMC_SUPPORT_POWER_SAVE ≠ 0
FS_MMC_CM_GetStatCounters()	FS_MMC_ENABLE_STATS ≠ 0
FS_MMC_CM_ResetStatCounters()	FS_MMC_ENABLE_STATS ≠ 0
FS_NAND_GetStatCounters()	FS_NAND_ENABLE_STATS ≠ 0
FS_NAND_ResetStatCounters()	FS_NAND_ENABLE_STATS ≠ 0
FS_NAND_SetEraseVerification()	FS_NAND_VERIFY_ERASE ≠ 0
FS_NAND_SetWriteVerification()	FS_NAND_VERIFY_WRITE ≠ 0
FS_NAND_UNI_GetStatCounters()	FS_NAND_ENABLE_STATS ≠ 0
FS_NAND_UNI_ResetStatCounters()	FS_NAND_ENABLE_STATS ≠ 0
FS_NAND_UNI_SetDriverBadBlockReclamation()	FS_NAND_RECLAIM_DRIVER_BAD_BLOCKS ≠ 0
FS_NAND_UNI_SetEraseVerification()	FS_NAND_VERIFY_ERASE ≠ 0
FS_NAND_UNI_SetNumBlocksPerGroup()	FS_NAND_SUPPORT_BLOCK_GROUPING ≠ 0
FS_NAND_UNI_SetWriteVerification()	FS_NAND_VERIFY_WRITE ≠ 0
FS_NAND_2048x8_EnableReadCache()	FS_NAND_SUPPORT_READ_CACHE ≠ 0
FS_NAND_2048x8_DisableReadCache()	FS_NAND_SUPPORT_READ_CACHE ≠ 0
FS_NAND_x8_Configure()	FS_NAND_SUPPORT_AUTO_DETECTION ≠ 0
FS_NAND_x_Configure()	FS_NAND_SUPPORT_AUTO_DETECTION = 0
FS_NAND_SPI_EnableReadCache()	FS_NAND_SUPPORT_READ_CACHE ≠ 0
FS_NAND_SPI_DisableReadCache()	FS_NAND_SUPPORT_READ_CACHE ≠ 0
FS_NAND_QSPI_EnableReadCache()	FS_NAND_SUPPORT_READ_CACHE ≠ 0
FS_NAND_QSPI_DisableReadCache()	FS_NAND_SUPPORT_READ_CACHE ≠ 0
FS_WINDRIVE_Configure()	_WIN32

Function	Condition
FS_WINDRIVE_ConfigureEx()	_WIN32
FS_WINDRIVE_SetGeometry()	_WIN32
FS_SetEncryptionObject()	FS_SUPPORT_ENCRYPTION \neq 0
FS_READAHEAD_GetStatCounters()	FS_READAHEAD_ENABLE_STATS \neq 0
FS_READAHEAD_ResetStatCounters()	FS_READAHEAD_ENABLE_STATS \neq 0

22.3 File naming differences

The names of some of the emFile header and source files were renamed in order to improve consistency. This change makes sure that the names of all the header and source files that ship with emFile begin with the prefix "FS_". In addition, the contents of some of the header and source files was moved to other files in order to keep the number of files to a minimum. The removal of some of the header files can possibly cause compiler errors. The errors can be corrected by including the name of the header file specified in the following table instead of the missing file header.

The next table lists the names of the header and source files that were renamed, moved or deleted in the version 5.x of emFile. The first column stores the original file name while the second column holds either the new file name or the file name that stores its contents. If the file has been deleted the name of the file is set to "-" in the second column. The third column stores a code indicating the operation that was performed on that file:

- M - contents of the file has been moved
- R - file has been renamed
- D - file has been deleted

Old file name	New file name	Operation
CRYPT_ALGO_AES.c	FS_CRYPT_ALGO_AES.c	R
CRYPT_ALGO_DES.c	FS_CRYPT_ALGO_DES.c	R
CRYPT_Drv.c	FS_CRYPT_Drv.c	R
CRYPT_File.c	FS_CRYPT_File.c	R
EFS.h	FS_EFS.h	R
EFS_API.c	FS_EFS_API.c	R
EFS_CheckDisk.c	FS_EFS_CheckDisk.c	R
EFS_Dir.c	FS_EFS_Dir.c	R
EFS_DirEntry.c	FS_EFS_DirEntry.c	R
EFS_Format.c	FS_EFS_Format.c	R
EFS_Intern.h	FS_EFS_Int.h	R
EFS_Misc.c	FS_EFS_Misc.c	R
EFS_Move.c	FS_EFS_Move.c	R
EFS_Open.c	FS_EFS_Open.c	R
EFS_Read.c	FS_EFS_Read.c	R
EFS_Rename.c	FS_EFS_Rename.c	R
EFS_SetEndOfFile.c	FS_EFS_SetEndOfFile.c	R
EFS_Write.c	FS_EFS_Write.c	R
FAT.h	FS_FAT.h	R
FAT_API.c	FS_FAT_API.c	R
FAT_CheckDisk.c	FS_FAT_CheckDisk.c	R
FAT_Dir.c	FS_FAT_Dir.c	R
FAT_DirEntry.c	FS_FAT_DirEntry.c	R
FAT_DiskInfo.c	FS_FAT_DiskInfo.c	R
FAT_Format.c	FS_FAT_Format.c	R
FAT_FormatSD.c	FS_FAT_FormatSD.c	R
FAT_Intern.h	FS_FAT_Int.h	R
FAT_Ioct.c	-	D
FAT_LFN.c	FS_FAT_LFN.c	R

Old file name	New file name	Operation
FAT_Misc.c	FS_FAT_Misc.c	R
FAT_Move.c	FS_FAT_Move.c	R
FAT_Open.c	FS_FAT_Open.c	R
FAT_Read.c	FS_FAT_Read.c	R
FAT_Rename.c	FS_FAT_Rename.c	R
FAT_SetEndOfFile.c	FS_FAT_SetEndOfFile.c	R
FAT_VolumeLabel.c	FS_FAT_VolumeLabel.c	R
FAT_Write.c	FS_FAT_Write.c	R
FS_AddSpaceHex.c	FS_Debug.c	M
FS_API.h	-	D
FS_AssignCache.c	FS_CACHE_Core.c	R
FS_CacheAll.c	FS_CACHE_All.c	R
FS_CacheMan.c	FS_CACHE_Man.c	R
FS_CacheMultiWay.c	FS_CACHE_MultiWay.c	R
FS_CacheRW.c	FS_CACHE_RW.c	R
FS_CacheRWQuota.c	FS_CACHE_RWQuota.c	R
FS_CLib.h	-	D
FS_Dev.h	-	D
FS_DF_X_HW.h	FS.h	M
FS_ErrorOut.c	FS_Debug.c	M
FS_FRead.c	FS_Read.c	M
FS_FWrite.c	FS_Write.c	M
FS_GetFilePos.c	-	D
FS_GetNumOpenFiles.c	FS_Misc.c	M
FS_Lbl.h	-	D
FS_Log.c	FS_Debug.c	M
FS_SetFilePos.c	-	D
FS_Warn.c	FS_Debug.c	M
FS__ECC256.c	FS_ECC256.c	R
IDE_Drv.c	FS_IDE_Drv.c	R
IDE_X_HW.h	FS.h	M
MMC_Drv.c	FS_MMC_Drv.c	R
MMC_SD_CardMode_Drv.c	FS_MMC_CM_Drv.c	R
MMC_SD_CardMode_X_HW.h	FS.h	M
MMC_X_HW.h	FS.h	M
NAND_Drv.c	FS_NAND_Drv.c	R
NAND_ECC_HW.c	FS_NAND_ECC_HW.c	R
NAND_ECC_SW_1Bit.c	FS_NAND_ECC_SW_1Bit.c	R
NAND_HW_SPI_X.h	FS.h	M
NAND_Misc.c	FS_NAND_Misc.c	R
NAND_PHY_2048x16.c	FS_NAND_PHY_2048x16.c	R
NAND_PHY_2048x8.c	FS_NAND_PHY_2048x8.c	R
NAND_PHY_4096x8.c	FS_NAND_PHY_4096x8.c	R

Old file name	New file name	Operation
NAND_PHY_512x8.c	FS_NAND_PHY_512x8.c	R
NAND_PHY_DataFlash.c	FS_NAND_PHY_DataFlash.c	R
NAND_PHY_ONFI.c	FS_NAND_PHY_ONFI.c	R
NAND_PHY_SPI.c	FS_NAND_PHY_SPI.c	R
NAND_PHY_x8.c	FS_NAND_PHY_x8.c	R
NAND_Private.h	FS_NAND_Int.h	R
NAND_UNI_Drv.c	FS_NAND_UNI_Drv.c	R
NAND_X_HW.h	FS.h	M
NOR_BM_Drv.c	FS_NOR_BM_Drv.c	R
NOR_Drv.c	FS_NOR_Drv.c	R
NOR_HW_CFI_1x16.c	FS_NOR_HW_CFI_1x16.c	R
NOR_HW_CFI_2x16.c	FS_NOR_HW_CFI_2x16.c	R
NOR_HW_SPI_X.h	FS.h	M
NOR_PHY_CFI.c	FS_NOR_PHY_CFI.c	R
NOR_PHY_DSPI.c	FS_NOR_PHY_DSPI.c	R
NOR_PHY_SFDP.c	FS_NOR_PHY_SFDP.c	R
NOR_PHY_SPIFI.c	FS_NOR_PHY_SPIFI.c	R
NOR_PHY_ST_M25.c	FS_NOR_PHY_ST_M25.c	R
NOR_Private.h	FS_NOR_Int.h	R
NOR_SPI_Dev.c	FS_NOR_SPI_Dev.c	R
NOR_SPI_Dev.h	FS.h	M
RAMDISK.c	FS_RAMDisk.c	R
WinDrive.c	FS_WinDrive.c	R
FS_X_embOS.c	FS_OS_embOS.c	R
FS_X_FreeRTOS.c	FS_OS_FreeRTOS.c	R
FS_X_None.c	FS_OS_None.c	R
FS_X_ucOS_II.c	FS_OS_ucOS_II.c	R
FS_X_Win32.c	FS_OS_Win32.c	R

Chapter 23

Support

This chapter should help if any problem occurs, e.g. with the use of the emFile functions, and describes how to contact the SEGGER support.

23.1 Contacting SEGGER support

If you are a registered emFile user and need to contact the SEGGER support, please send the following information via email to support@segger.com:

- The emFile version.
- Your emFile registration number.
- If you are unsure about the above information, you may also use the name of the shipped emFile ZIP-file (which contains the above information).
- A detailed description of the problem.
- (Optional) A project with which we can reproduce the problem.

Chapter 24

FAQs

This chapter contains a collection of frequently asked questions (FAQs) together with their respective answers.

24.1 Questions and answers

Q: Is my data safe when an unexpected reset occurs?

A: In general, the data which is already on the storage device is safe. If a read operation is interrupted, this is completely harmless. If a write operation is interrupted, then the data written during this operation may or may not be stored on the storage device. This depends on when the unexpected reset occurred. In any case, the data which was on the storage device prior to the write operation is not affected. This is true if the storage device is not affected by the reset, meaning that the storage device is able to complete a pending write operation. All this is true for the device drivers that come with emFile. However, the structure of the FAT or EFS file systems can be corrupted by an unexpected reset. This can be prevented by using the Journaling component.

Q: I use FAT and I can only create a limited number of root directory entries. Why?

A: With FAT12 and FAT16 the root directory is special because it has a fixed size. The size of the root directory can be specified at format, but once formatted this value is constant and determines the number of entries the root directory can hold. FAT32 does not have this limitation and the size of the root directory can be variable. Microsoft's "FAT32 File System Specification" says on page 22: "For FAT12 and FAT16 media, the root directory is located in a fixed location on the disk immediately following the last FAT and is of a fixed size in sectors computed from the `BPB_RootEntCnt` value [...] For FAT32, the root directory can be of variable size and is a cluster chain, just like any other directory is." Here `BPB_RootEntCnt` specifies the count of 32-byte directory entries in the root directory and as the citation says, the number of sectors is computed from this value. In addition, which file system is used depends on the size of the storage medium, that is the number of clusters and the cluster size, where each cluster contains one or more sectors. Using small cluster sizes (for example cluster size equal to 512 bytes) one can use FAT32 on a storage medium with more than 32 MB. (FAT16 can address at least 216 clusters with a 512 byte cluster size. That is $65536 * 512 = 33554432$ bytes = 32768 KB = 32 MB). If the storage medium is smaller than or equal to 32 MB or the cluster size is greater than 512 bytes, FAT32 cannot be used. The second parameter of the `FS_Format()` API function can be used to set a custom root directory size for FAT12 / FAT16 volume. This parameter is a pointer to a `FS_FORMAT_INFO` structure that contains a member named `NumRootDirEntries` which can be used to specify the number of entries in the root directory.

Chapter 25

Glossary

List of some of the terms used in this manual together with a short explanation.