

VCS Series Part Number Tree

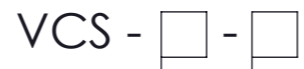

CABLE OPTION

0 or 2 0.16M Single Insulated PVC
 1, 3, 7 or 9 0.6M Single Insulated PVC

MATERIAL

x1 or x2 Polypropylene / Float Foamed Polypropylene 30mm (Internal fit only)
 x3 or x4 Polypropylene / Float Hollow Polypropylene
 x5 or x6 Nylon / Float Hollow Nylon
 x7 or x8 Kynar / Float Hollow Polypropylene (PPS)

SWITCH

Cable Option 2x or 3x SPST MAX 100 VDC, 250VRMS, 1AMP, 50 WATT

FITTING OPTION

1/8" NPT Taper (Odd Part Number)

SEALING MATERIAL

None (1/8" NPT fitting only)

NOT ALL OPTIONS AVAILABLE

Unless otherwise specified tolerances are	
Cable Lengths	
Cable Lengths	Tolerance
100 - 200 mm	+/-5
500 mm	+/-10
1000 mm	+/-20
2000 mm	+/-50
5000 mm	+/-100
General Tolerances	
Dimension	Tolerances
<20 mm	+/-0.25
20 - 50 mm	+/-0.50
50 - 100 mm	+/-0.75
100 - 150 mm	+/-1.00
Angles	+/-0.5 Deg

SERIES	TCPN
VCS-01	20017615-01
VCS-05	20017615-05

DIMENSIONS: mm	TOLERANCES UNLESS OTHERWISE SPECIFIED:
	0 PLC - 1 PLC +0.5 2 PLC +0.13 3 PLC +0.013 4 PLC +0.0001
ANGLES ±	
SURFACE TEXTURE	

DWN	L Hernandez	MATERIAL	WEIGHT	kg					
CHK	R Cooper								
APVD	J Pendleton								
NAME	VCS 1_8NPT TOP LEVEL CATALOG DWG								
SCALE	1:1	SIZE	A3	DRAWING NO	20017615-00	SHEET	1 OF 2	REV	A

DWG NO 20017615-00

THIS DRAWING IS A CONTROLLED DOCUMENT

THIS INFORMATION IS CONFIDENTIAL AND PROPRIETARY TO TYCO ELECTRONICS CORPORATION AND ITS WORLDWIDE SUBSIDIARIES AND AFFILIATES (TE). IT MAY NOT BE DISCLOSED TO ANYONE, OTHER THAN TE PERSONNEL, WITHOUT AUTHORIZATION FROM TE (www.TE.com).

USED ON

DWG NO
20017615-00

THIS DRAWING IS A CONTROLLED DOCUMENT

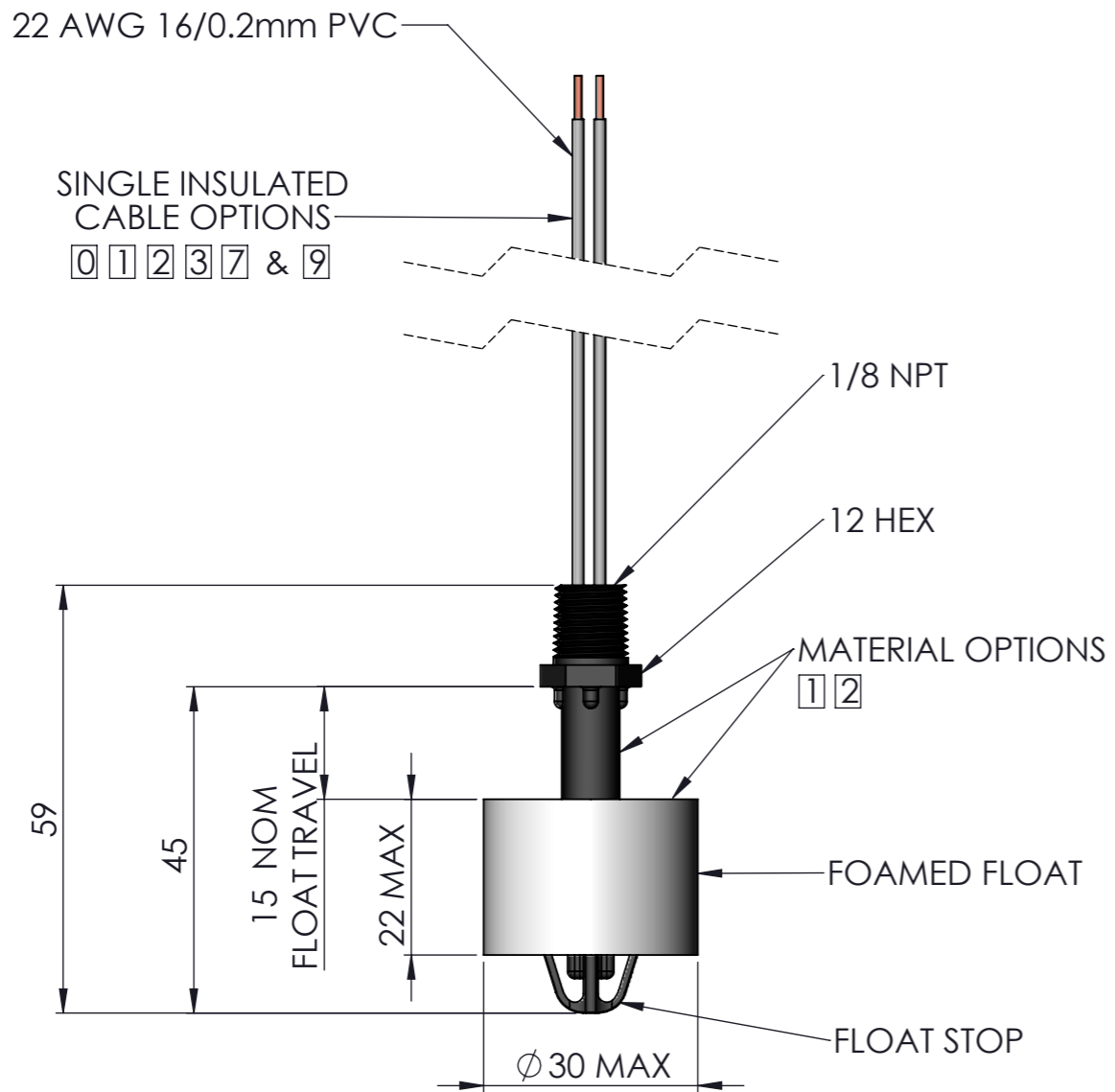

VCS-01

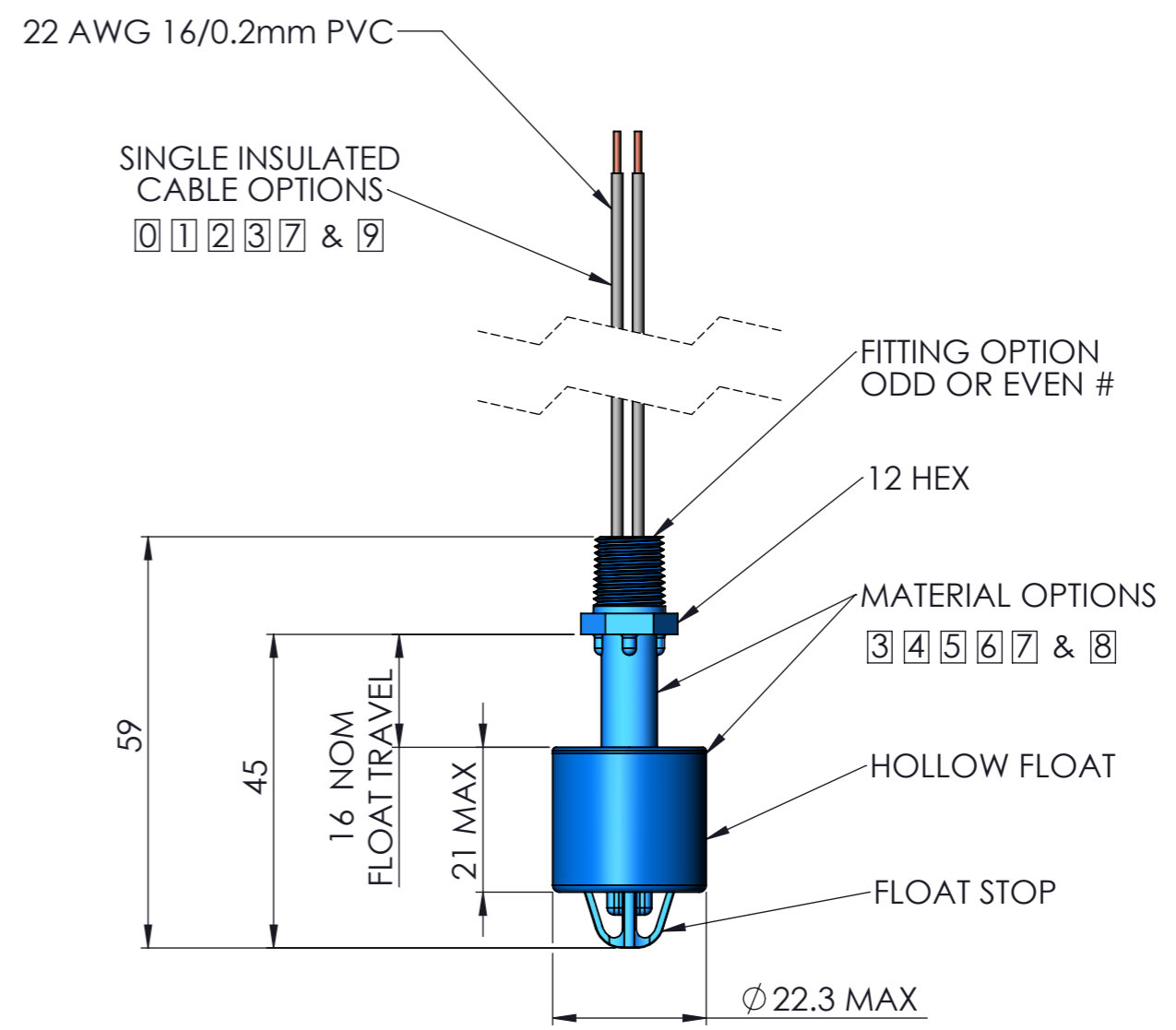

VCS-05

NOTES:

- 1. REED SWITCH IS EITHER NORMALLY OPEN OR CLOSED DEPENDING ON FLOAT ORIENTATION

DIMENSIONS: mm	TOLERANCES UNLESS OTHERWISE SPECIFIED:
	0 PLC -
	1 PLC +0.5
	2 PLC +0.13
	3 PLC +0.013
	4 PLC +0.0001
ANGLES ±	
SURFACE TEXTURE	

DWN L Hernandez	MATERIAL	WEIGHT kg
CHK R Cooper		
APVD J Pendleton		
NAME VCS 1_8NPT TOP LEVEL CATALOG DWG		
SCALE 1:1	SIZE A3	DRAWING NO 20017615-00
SHEET 2 OF 2		REV A

THIS INFORMATION IS CONFIDENTIAL AND PROPRIETARY TO TYCO ELECTRONICS CORPORATION AND ITS WORLDWIDE SUBSIDIARIES AND AFFILIATES (TE). IT MAY NOT BE DISCLOSED TO ANYONE, OTHER THAN TE PERSONNEL, WITHOUT AUTHORIZATION FROM TE (www.TE.com).