

Mounting: Top & Bottom Entry
 Material: Nylon 6.6
 Housing Material: Glass Filled Nylon 6.6
 Housing Colour: Blue
 Float Material: Glass Filled Nylon 6.6
 Connection Type: Stripped Cables
 Cable Type: 2 x 22AWG 16/0.2mm PVC insulated 0.5m long to UL/CSA/BS6361
 Cable Colour: Black/Black
 Sealing Components: Nitrile

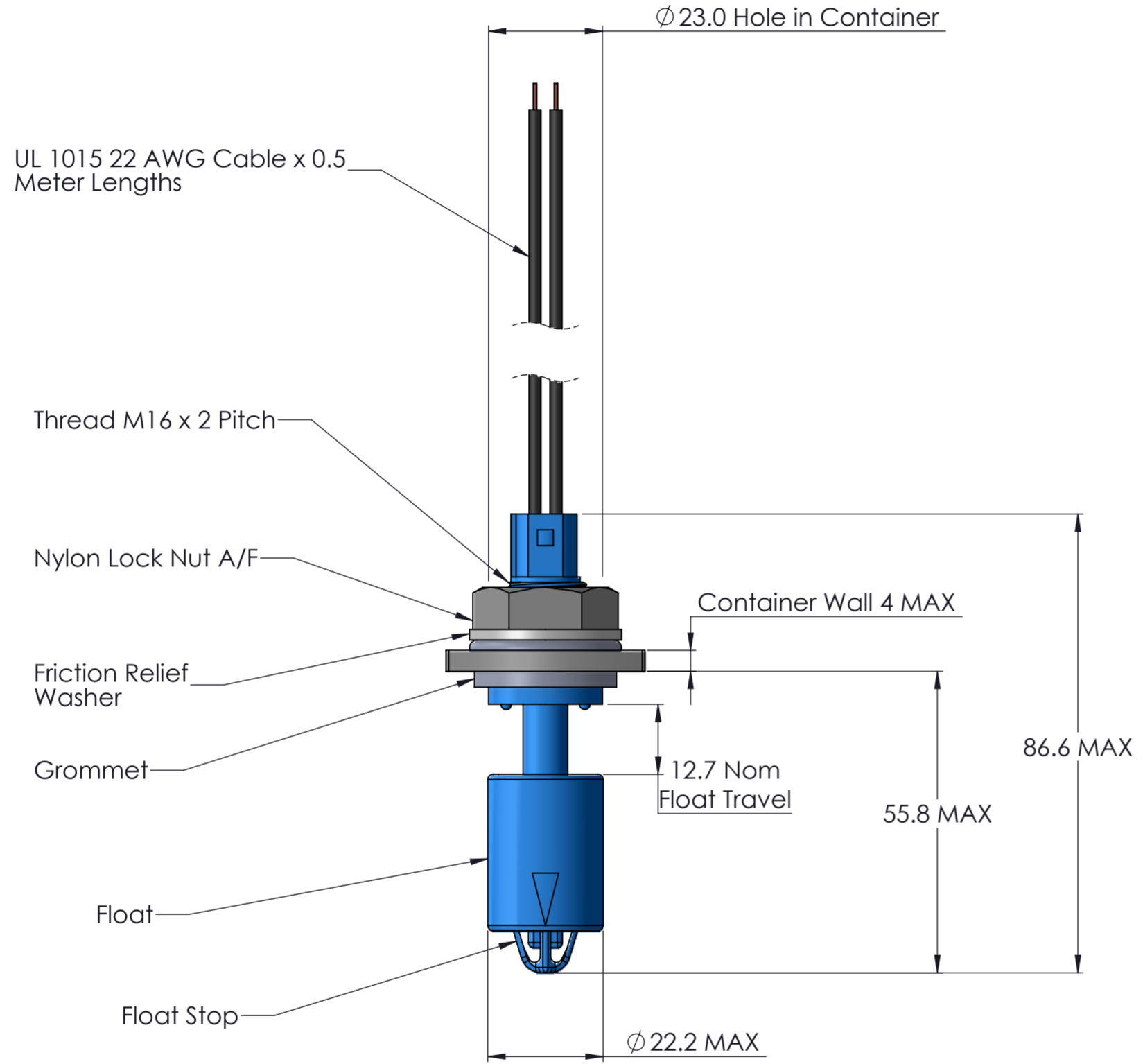

External Fitting

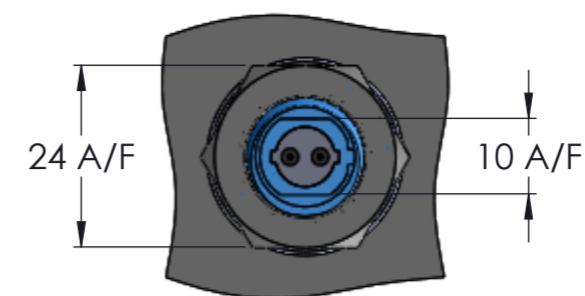
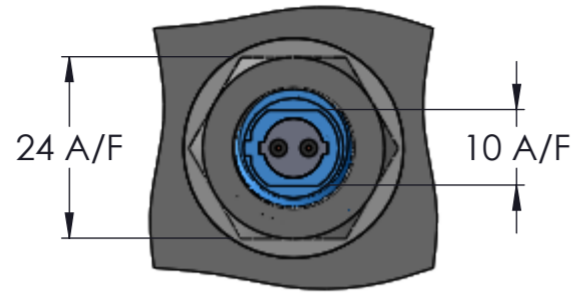
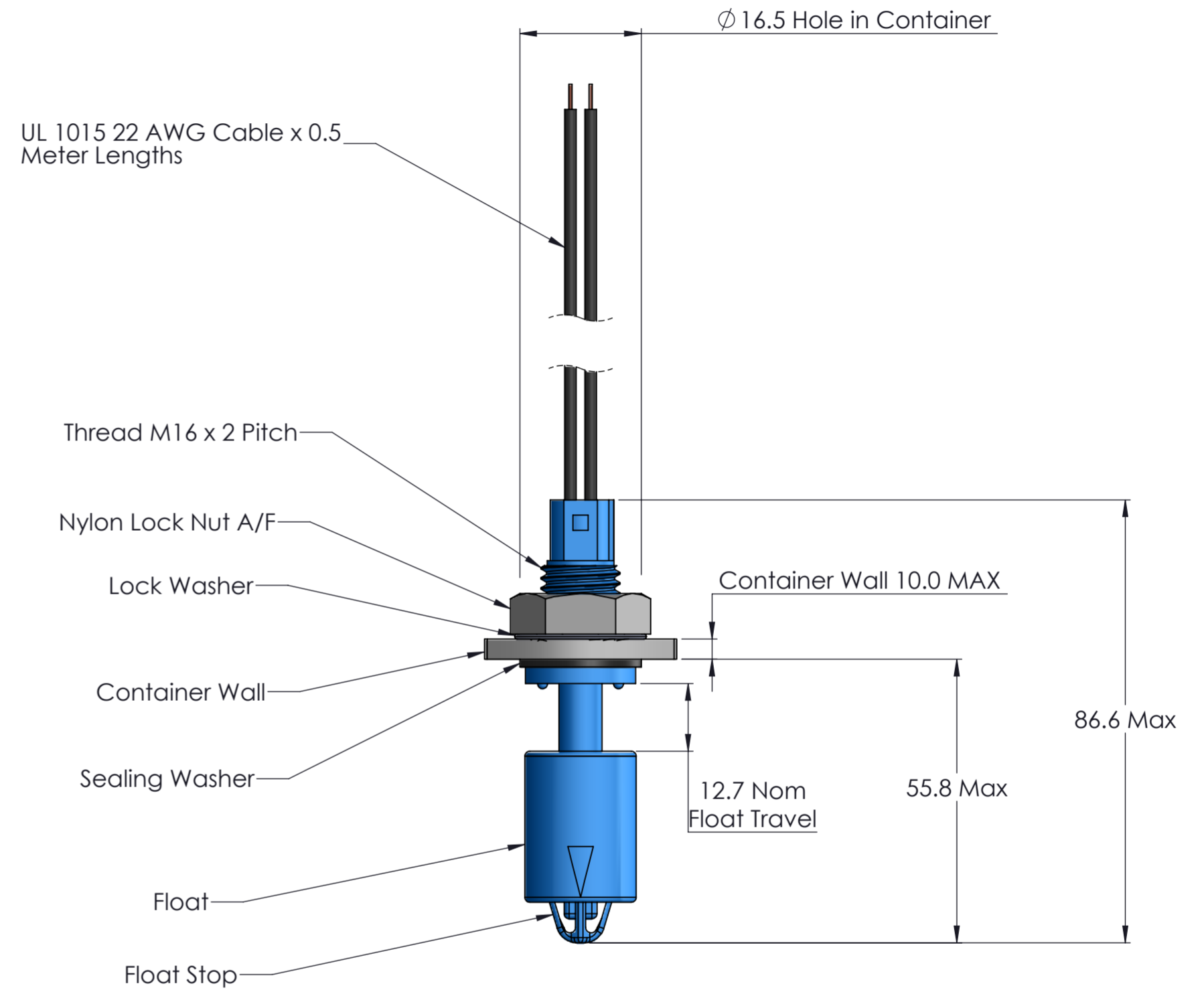

Internal Fitting

NOTE

1. UNIVERSAL KIT TYPE SENSOR SUPPLIED IN A BAG WITH NUT, WASHER AND GROMMET LOOSE, FOR EITHER FIT OPTION ASSEMBLY.
2. FLOAT SHOWN WITH ORIENTATION MARK IS NORMALLY OPEN, ORIENTATION MAY BE MIRRORED TO BE NORMALLY CLOSED.

DIMENSIONS:		TOLERANCES UNLESS OTHERWISE SPECIFIED:	
mm		0 PLC	.5
		1 PLC	.13
		2 PLC	.013
		3 PLC	.0013
		4 PLC	.0001
ANGLES ±			
SURFACE TEXTURE		√	

DWN	L Hernandez	MATERIAL		WEIGHT	kg
CHK	R Cooper				
APVD	J Pendleton				
NAME	VS301-51N VERTICAL LEVEL SENSOR				
SCALE	1:1	SIZE	A2	DRAWING NO	20017769-00
		SHEET	1	OF	1
		REV			A

THIS INFORMATION IS CONFIDENTIAL AND PROPRIETARY TO TYCO ELECTRONICS CORPORATION AND ITS WORLDWIDE SUBSIDIARIES AND AFFILIATES (TE). IT MAY NOT BE DISCLOSED TO ANYONE, OTHER THAN TE PERSONNEL, WITHOUT AUTHORIZATION FROM TE (www.te.com).