

HMI SERIES – AMPLIFIED PRESSURE SENSORS

The HMI pressure sensors provide digital output signals via a I²C bus interface and utilize precision digital signal conditioning to achieve high accuracies. The sensors offer an increased media compatibility to measure gases and liquids. 5 V and 3 V supply versions are available. Very small SIL and DIP housings allow for space- saving PCB-mounting. All HMI pressure sensors can be modified according to customer specific requirements.

Features

- Pressure ranges from 2.5 mbar to 10 bar, 1 psi to 150 psi gage or differential pressure
- Increased media compatibility⁽¹⁾
- Digital I²C bus output
- Precision ASIC signal conditioning
- Calibrated and temperature compensated⁽²⁾
- SIL and DIP housings

Applications

- Industrial controls
- Pneumatic controls
- Environmental controls
- HVAC
- Analytical instruments

Certificates

- Quality Management System according to EN ISO 13485:2003 and EN ISO 9001:2008
- RoHS and REACH compliant

Media compatibility

High pressure port: To be used with gases and liquids which are compatible with the wetted materials (high temperature polyamide, ceramic AL₂O₃, epoxy, fluorosilicone, glass, silicon).

Low pressure port: To be used with non-corrosive, non-ionic working fluids such as clean dry air, dry gases and the like.

[CLICK HERE >](#)
CONNECT WITH A SPECIALIST

HMI SERIES – AMPLIFIED PRESSURE SENSORS

Maximum ratings

Parameter		Min.	Typ.	Max.	Unit
Supply voltage (VS) ⁽³⁾	HMIxxx3	2.7	3.0	4.2	V _{bc}
	HMIxxx5	4.2	5.0	5.5	
Output current	Sink		1		mA
	Source		1		
Temperature ranges	Compensated	-20		+85	°C
	Operating	-20		+85	
	Storage ⁽⁴⁾	-40		+125	
Humidity limits (non-condensing) ⁽⁵⁾				95	%RH
Vibration	10 to 2000 Hz, random (EN 60068-2-64)			10	g
Mechanical shock	11 ms (EN60068-2-27)			50	
Lead solder temperature	(JESD22-B106D)			270	°C

Pressure sensor characteristics

Part no.	Operating pressure	Proof pressure ⁽⁶⁾
HMIM2x5Uxxx	0 to 2.5 mbar	100 mbar
HMIM2x5Bxxx	0 to ±2.5 mba	
HMIM005Uxxx	0 to 5 mbar	
HMIM005Bxxx	0 to ±5 mbar	
HMIM010Uxxx	0 to 10 mbar	
HMIM010Bxxx	0 to ±10 mbar	
HMIM020Uxxx	0 to 20 mbar	300 mbar
HMIM020Bxxx	0 to ±20 mbar	
HMIM050Uxxx	0 to 50 mbar	
HMIM050Bxxx	0 to ±50 mbar	
HMIM100Uxxx	0 to 100 mbar	
HMIM100Bxxx	0 to ±100 mbar	
HMIM250Uxxx	0 to 250 mbar	2 bar
HMIM250Bxxx	0 to ±250 mbar	
HMIB001Uxxx	0 to 1 bar	5 bar
HMIB001Bxxx	0 to ±1 bar	
HMIB2x5Uxxx	0 to 2.5 bar	10 bar
HMIB005Uxxx	0 to 5 bar	14 bar
HMIB010Uxxx	0 to 10 bar	
HMIP001Uxxx	0 to 1 psi	30 psi
HMIP001Bxxx	0 to ±1 psi	
HMIP100Uxxx	0 to 100 psi	

Other pressure ranges are available on request. Please contact your local representative.

HMI SERIES – AMPLIFIED PRESSURE SENSORS

Performance characteristics ⁽⁷⁾

(T_A=25 °C, RH=50 %, for HMIxxx3 devices (V_S=3.0 V_{DC}) digital output signal is non-ratiometric to V_S in the range of V_S =2.7 to 4.2 V, for HMIxxx5 devices (V_S=5.0 V_{DC}) digital output signal is non-ratiometric to V_S in the range of V_S =4.2 to 5.5 V)

Parameter		Min.	Typ.	Max.	Unit
Non-linearity (-20 to 85 °C) ⁽⁸⁾				±0.25	%FSS
Accuracy ⁽⁹⁾				±0.25	
Total accuracy (-20 to 85 °C) ⁽¹⁰⁾	up to 5 mbar			±2	
	10 mbar to 50			±1.25	
	all others			±0.75	
Response delay ⁽¹¹⁾			0.5		ms
A/D resolution			12		bit
D/A resolution				11	
Current consumption	5 V devices	<1 bar	4.2		mA
		all others	5.3		
	3 V devices	<1 bar	3.7		
		all others	4.5		

Pressure ranges up to 5 mbar

Unidirectional devices

Parameter	Min.	Typ.	Max.	Unit
Zero pressure offset	2460	3000	3540	counts
Full scale span (FSS) ⁽¹²⁾		27000		
Full scale output	29460	30000	30540	

Bidirectional devices

Parameter	Min.	Typ.	Max.	Unit	
Zero pressure offset	15960	16500	17040	counts	
Full scale span (FSS) ⁽¹²⁾		27000			
Full scale output	@ max. specified pressure	29460	30000		30540
	@ min. specified pressure	2460	3000		3540

HMI SERIES – AMPLIFIED PRESSURE SENSORS

Performance characteristics (Cont.) ⁽⁷⁾

(T_A=25 °C, RH=50 %, for HMIxxx3 devices (V_S=3.0 V_{DC}) digital output signal is non-ratiometric to V_S in the range of V_S =2.7 to 4.2 V, for HMIxxx5 devices (V_S=5.0 V_{DC}) digital output signal is non-ratiometric to V_S in the range of V_S =4.2 to 5.5 V)

Pressure ranges from 10 mbar to 50 mbar / 1 psi

Unidirectional devices

Parameter	Min.	Typ.	Max.	Unit
Zero pressure offset	2663	3000	3338	counts
Full scale span (FSS) ⁽¹²⁾		27000		
Full scale output	29663	30000	30338	

Bidirectional devices

Parameter	Min.	Typ.	Max.	Unit	
Zero pressure offset	16163	16500	17040	counts	
Full scale span (FSS) ⁽¹²⁾		27000			
Full scale output	@ max. specified pressure	29663	30000		30338
	@ min. specified pressure	2663	3000		3338

All other pressure ranges

Unidirectional devices

Parameter	Min.	Typ.	Max.	Unit
Zero pressure offset	2798	3000	3203	counts
Full scale span (FSS) ⁽¹²⁾		27000		
Full scale output	29798	30000	30203	

Bidirectional devices

Parameter	Min.	Typ.	Max.	Unit	
Zero pressure offset	16298	16500	16703	counts	
Full scale span (FSS) ⁽¹²⁾		27000			
Full scale output	@ max. specified pressure	29798	30000		30203
	@ min. specified pressure	2798	3000		3203

I²C Bus

Introduction

The HMI is capable to generate a digital output signal. The device runs a cyclic program, which will store a corrected pressure value with 12 bit resolution about every 250 μs within the output registers of the internal ASIC. In order to use the sensor for digital signal readout, it should be connected to a bidirectional I²C-bus.

According to the I²C-bus specification, the bus is controlled by a master device, which generates the clock signal, controls the bus access and generates START and STOP conditions. The HMI is designed to work as a slave, hence it will only respond to requests from a master device.

Digital I²C interface

The HMI complies with the following protocol (Fig. 1):

Bus not busy: During idle periods both data line (SDA) and clock line (SCL) remain HIGH.

START condition (S): HIGH to LOW transition of SDA line while clock (SCL) is HIGH is interpreted as START condition. START conditions are always generated by the master. Each initial request for a pressure value has to begin with a START condition.

STOP condition (P): LOW to HIGH transition of SDA line while clock (SCL) is HIGH determines STOP condition. STOP conditions are always generated by the master. More than one request for the current pressure value can be transmitted without generation of intermediate STOP condition.

DATA valid (D): State of data line represents valid data when, after START condition, data line is stable for duration of HIGH period of clock signal. Data on line must be changed during LOW period of clock signal. There is one clock pulse per bit of data.

Acknowledge (A): Data is transferred in pieces of 8 bits (1 byte) on serial bus, MSB first. After each byte receiving device whether master or slave – is obliged to pull data line LOW as acknowledge for reception of data. Master must generate an extra clock pulse for this purpose. When acknowledge is missed, slave transmitter becomes inactive. It is on master either to send last com-mand again or to generate STOP condition in that case.

Slave address: The I²C-bus master-slave concept requires a unique address for each device. The HMI has a preconfigured slave address (1111000xb). By factory programming it is possible to define a secondary slave address additional to the general one. According to I²C specification 127 different addresses are available. The sensor will then listen to both slave addresses. After generating a START condition the master sends the address byte containing a 7 bit address followed by a data direction bit (R/W). A "0" indicates a transmission from master to slave (WRITE), a "1" indicates a data request (READ).

DATA operation: The sensor starts to send 2 data bytes containing the current pressure value as a 15 bit information placed in the output registers

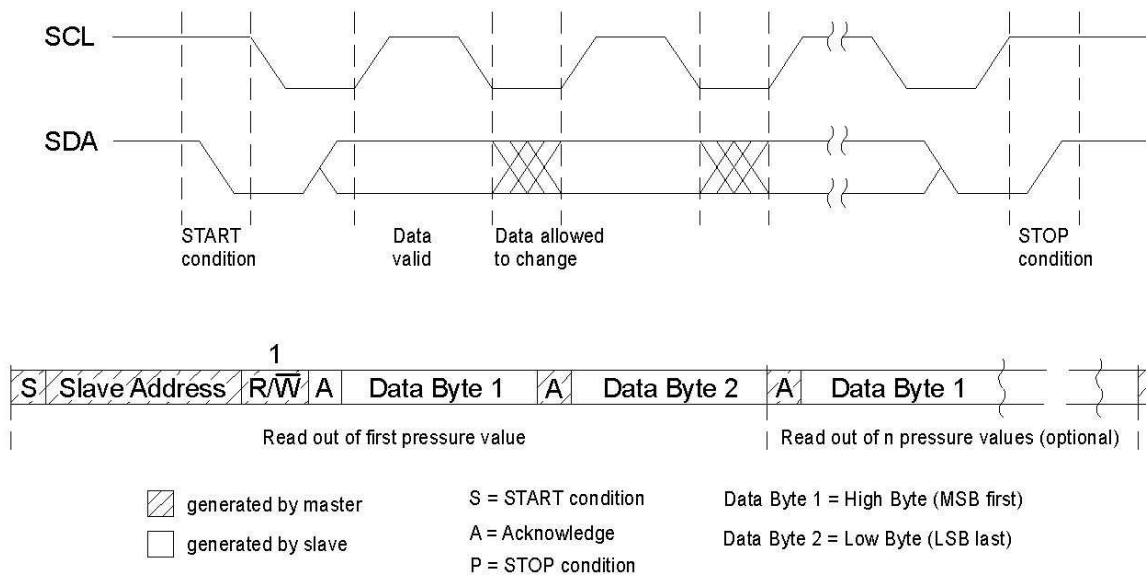

Fig. 1: I²C bus protocol

I²C Interface parameters

Parameter	Symbol	Min.	Typ.	Max.	Unit
Input high level		90		100	% of Vs
Input low level		0		10	
Output low level				10	
Pull-up resistor		1		5	kΩ
Load capacitance @ SDA	C _{SDA}			400	pF
Input capacitance @ SDA/SCL	C _{I2C IN}			10	
SCL clock frequency	F _{SCL}	100*		400	kHz
Bus free time between STOP and START condition	t _{BUF}	1.3			μs
Hold time (repeated) START condition, to first clock pulse	t _{HD,STA}	0.8			
LOW period of SCL	t _{LOW}	1.3			
HIGH period of SCL	t _{HIGH}	0.6			
Setup time repeated START condition	t _{SU,STA}	1			
Data hold time	t _{HD,DAT}	0			
Data setup time	t _{SU,DAT}	0.2			
Rise time of both SDA and SCL	t _R			0.3	
Fall time of both SDA and SCL	t _F			0.3	
Setup time for STOP condition	t _{SU,STO}	0.6			

*recommended

Note: TE Connectivity recommends communication speeds of at least 100 kHz (max. 400 kHz). Please contact us for further information.

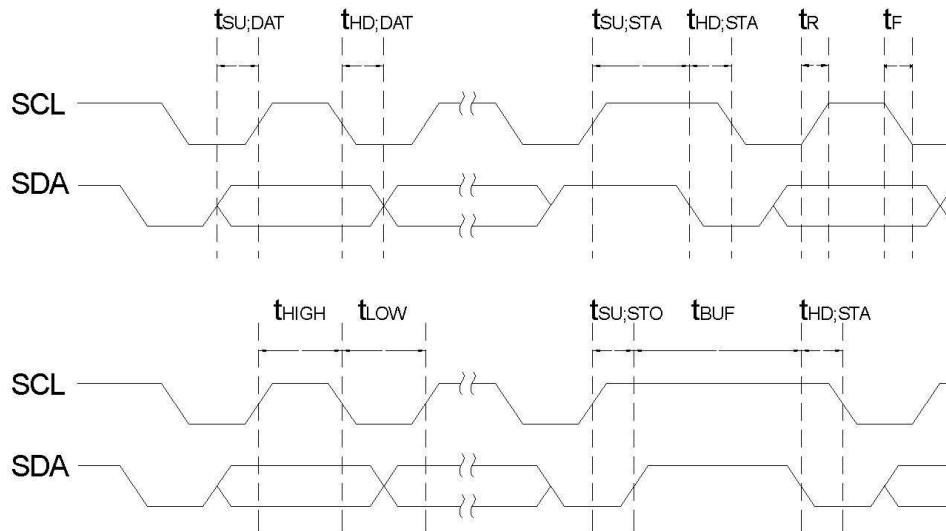
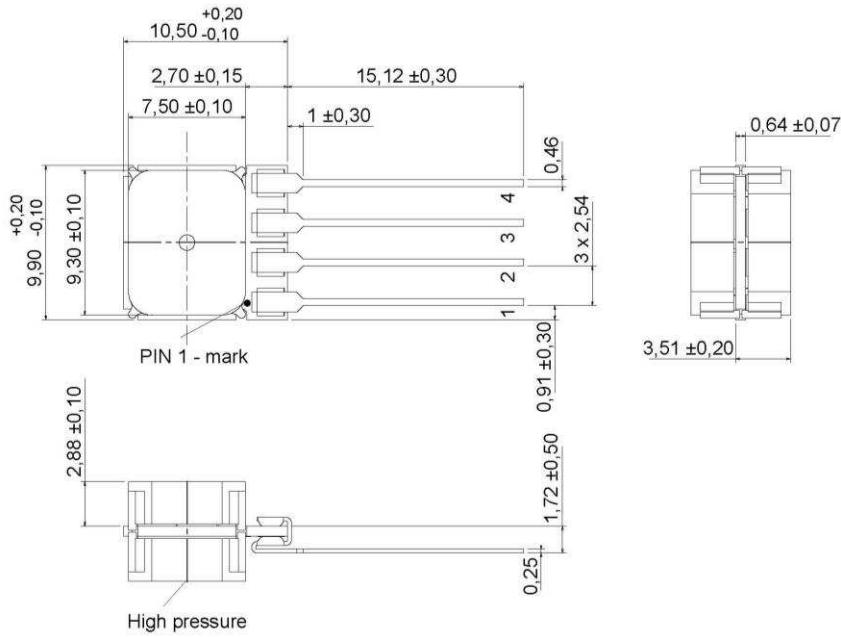

Fig. 2: Timing characteristics

HMI SERIES – AMPLIFIED PRESSURE SENSORS

Dimensional drawing

HMIxxxU1xxx (SIL, axial no ports)



Electrical connection

Pin	connection
1	+Vs
2	GND
3	SCL
4	SDA

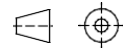

first angle projection
dimensions in mm

HMIxxxW1xxx (DIP, axial no ports)

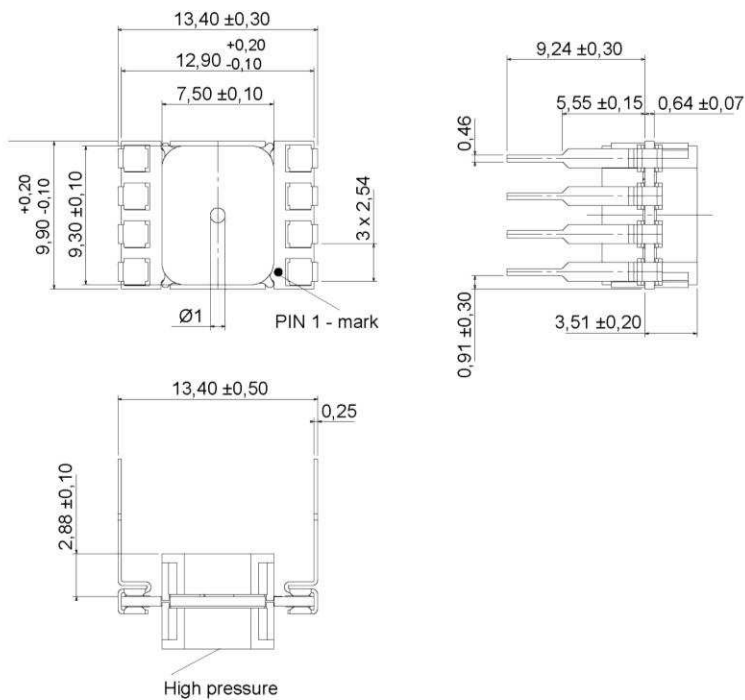

Pin	connection
1	+Vs
2	GND
3	C
4	I/C*
5	SCL
6	I/C*
7	I/C*
8	SDA

* internal connection. Do not connect for any reason

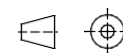

first angle projection
dimensions in mm

HMI SERIES – AMPLIFIED PRESSURE SENSORS

Dimensional drawing

HMIxxxX7xxx (SIL, 1 port axial, barbed)

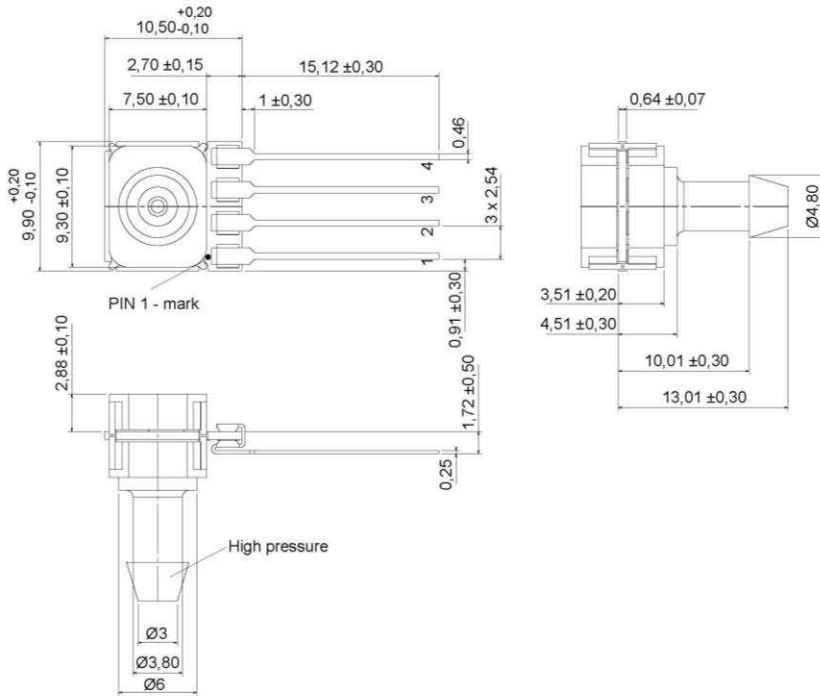

Electrical connection

Pin	connection
1	+Vs
2	GND
3	SCL
4	SDA

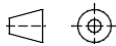
first angle projection
dimensions in mm

HMIxxxU7xxx (SIL, 2 ports axial, opposite side, barbed)

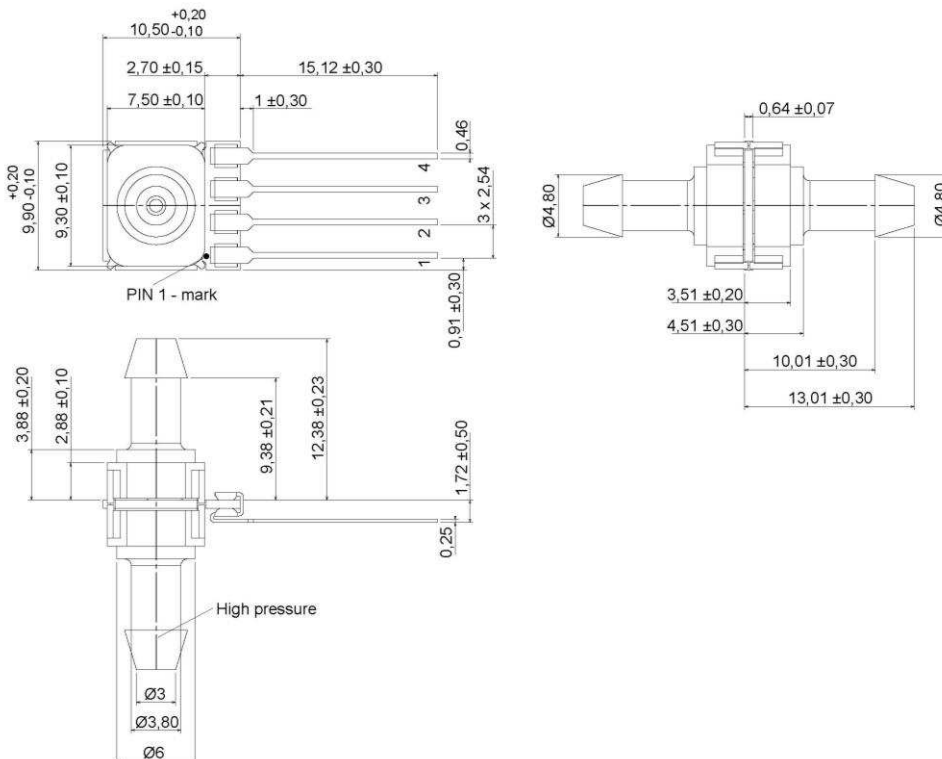

Pin	connection
1	+Vs
2	GND
3	SCL
4	SDA

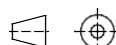
first angle projection
dimensions in mm

HMI SERIES – AMPLIFIED PRESSURE SENSORS

Dimensional drawing

HMIxxxZ7xxx (DIP, 1 port axial, barbed)

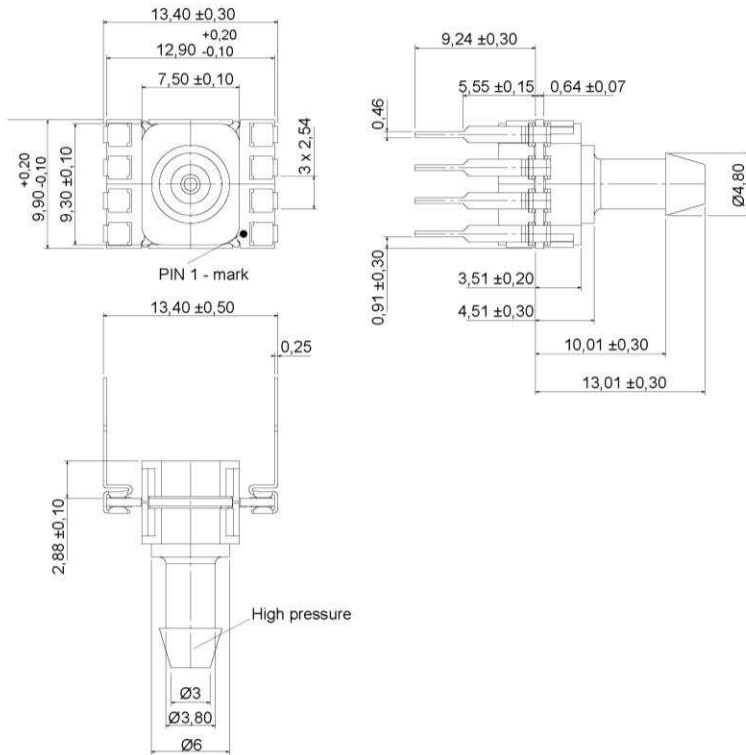

Electrical connection

Pin	connection
1	+Vs
2	GND
3	C
4	I/C*
5	SCL
6	I/C*
7	I/C*
8	SDA

* internal connection. Do not connect for any reason

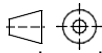
first angle projection
dimensions in mm

HMIxxxU6xxx (SIL, 2 ports axial, opposite side, straight big)

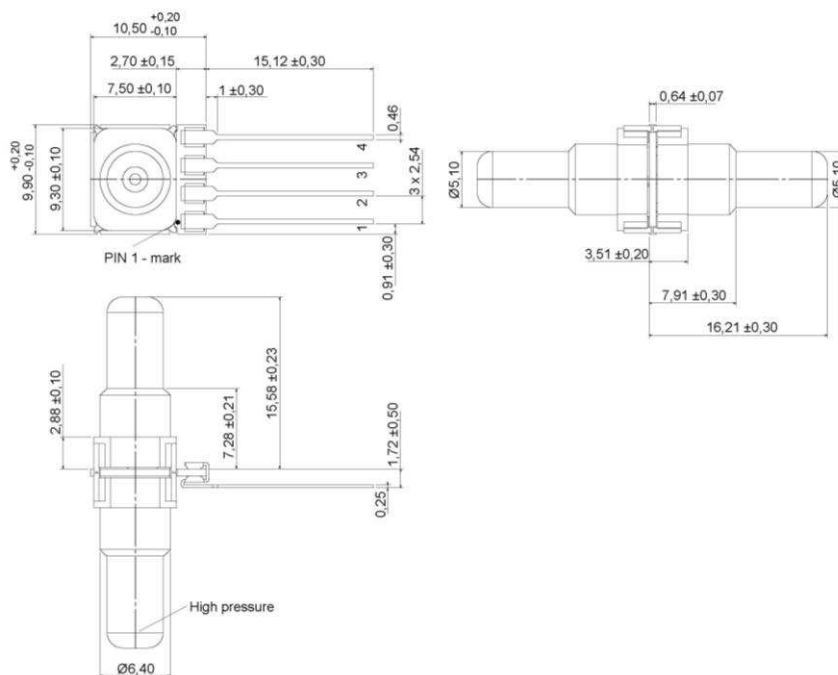

Pin	connection
1	+Vs
2	GND
3	SCL
4	SDA

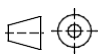
first angle projection
dimensions in mm

HMI SERIES – AMPLIFIED PRESSURE SENSORS

Dimensional drawing

HMIxxxX6xxx (SIL, 1 port axial, straight big)

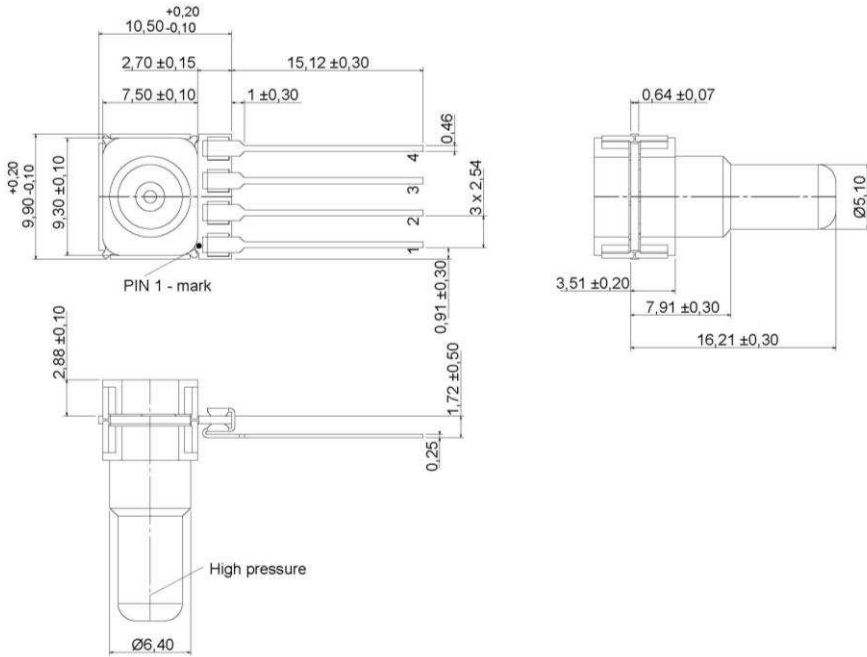

Electrical connection

Pin	connection
1	+Vs
2	GND
3	SCL
4	SDA

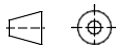
 first angle projection
dimensions in mm

HMIxxxZ6xxx (DIP, 1 port axial, straight big)

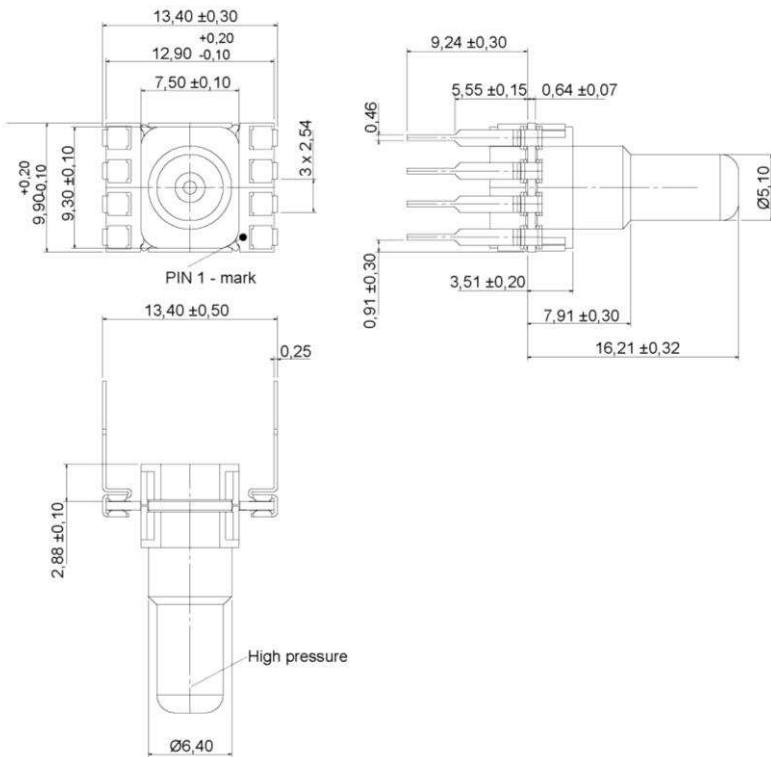

Pin	connection
1	+Vs
2	GND
3	C
4	I/C*
5	SCL
6	I/C*
7	I/C*
8	SDA

* internal connection. Do not connect for any reason

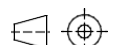
 first angle projection
dimensions in mm

HMI SERIES – AMPLIFIED PRESSURE SENSORS

Dimensional drawing

HMIxxxU5xxx (SIL, 2 ports axial, opposite side, needle big)

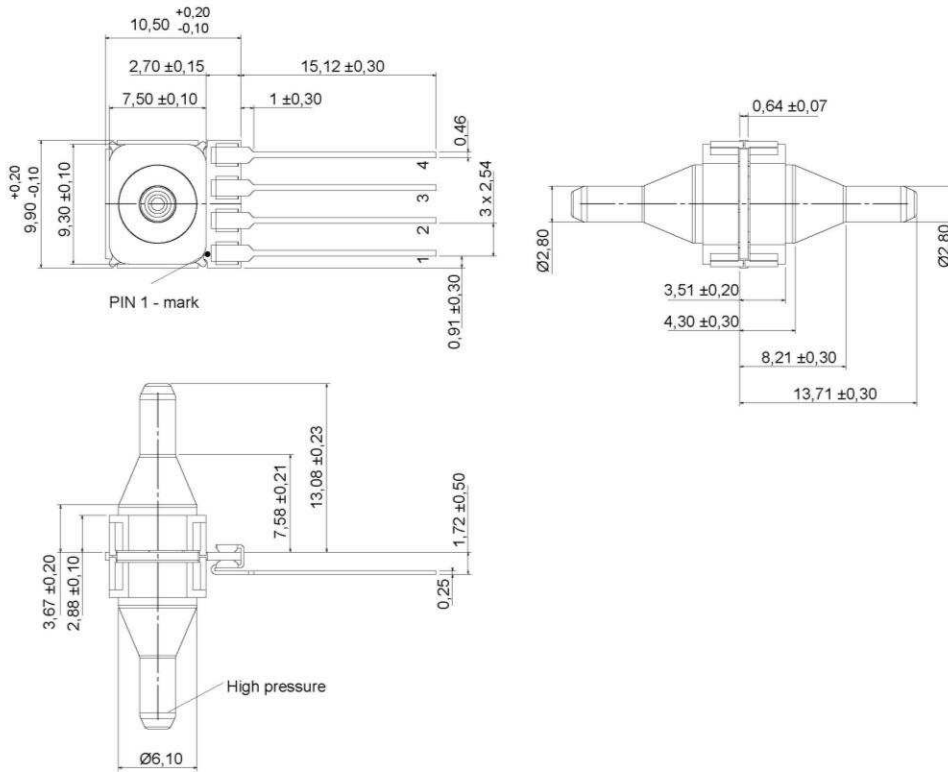

Electrical connection

Pin	connection
1	+Vs
2	GND
3	SCL
4	SDA

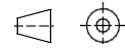

first angle projection
dimensions in mm

HMIxxxX5xxx (SIL, 1 port axial, needle big)

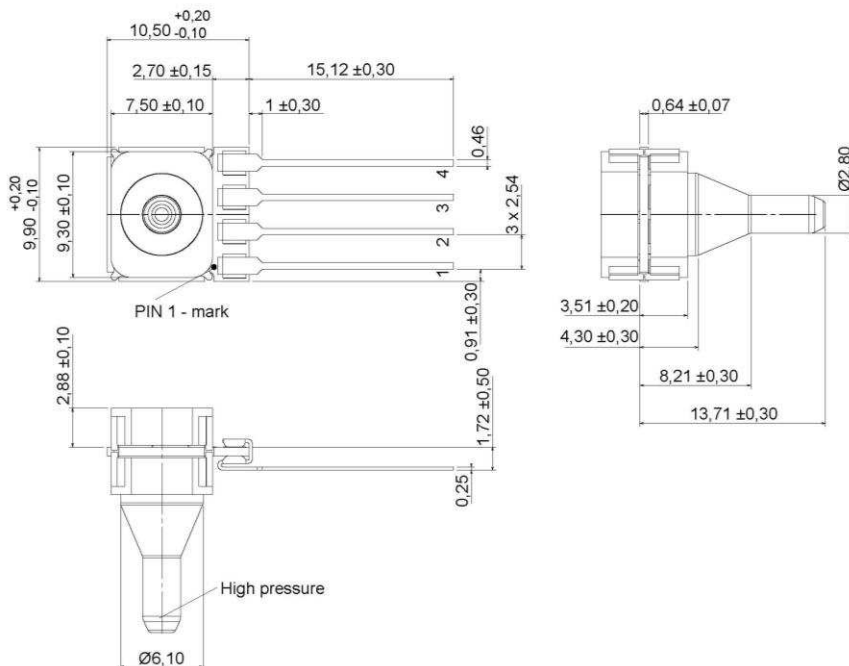

Pin	connection
1	+Vs
2	GND
3	SCL
4	SDA

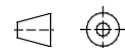

first angle projection
dimensions in mm

HMI SERIES – AMPLIFIED PRESSURE SENSORS

Dimensional drawing

HMIxxxZ5xxx (DIP, 1 port axial, needle big)

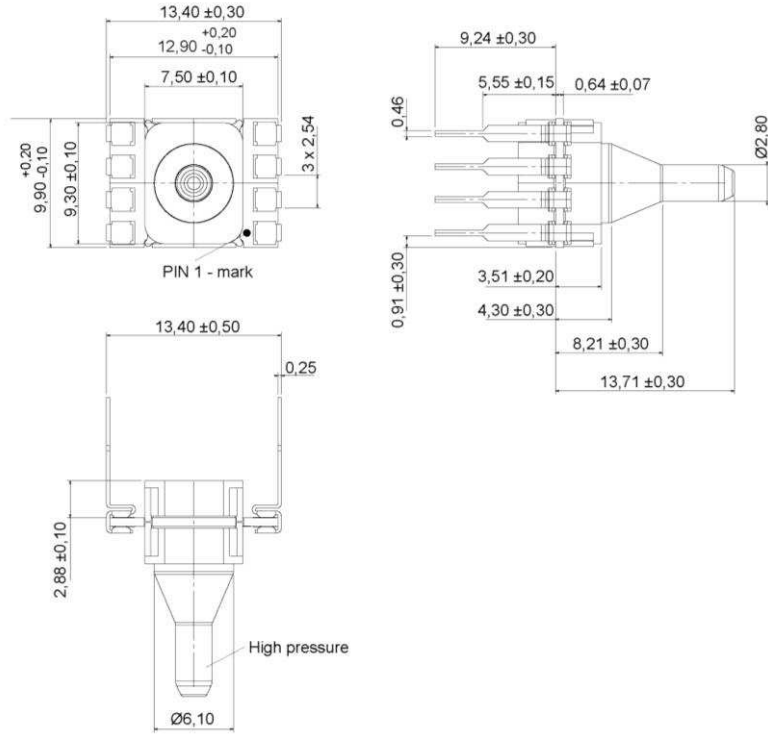

Electrical connection

Pin	connection
1	+Vs
2	GND
3	C
4	I/C*
5	SCL
6	I/C*
7	I/C*
8	SDA

* internal connection. Do not connect for any reason

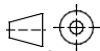
 first angle projection
dimensions in mm

Electrical connection (cont.)

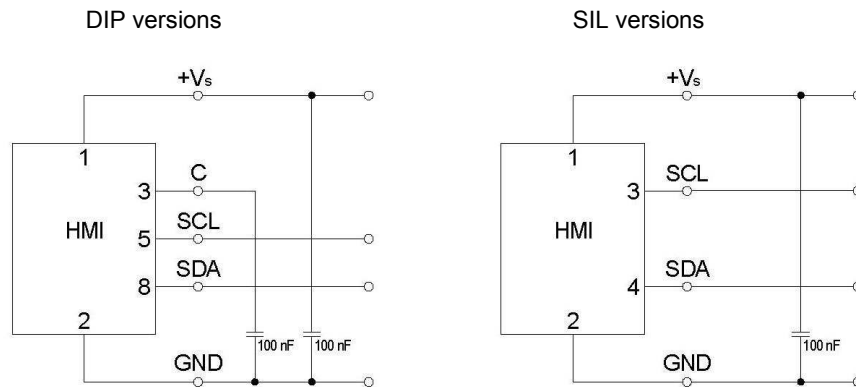

HMI SERIES – AMPLIFIED PRESSURE SENSORS

Part numbering key

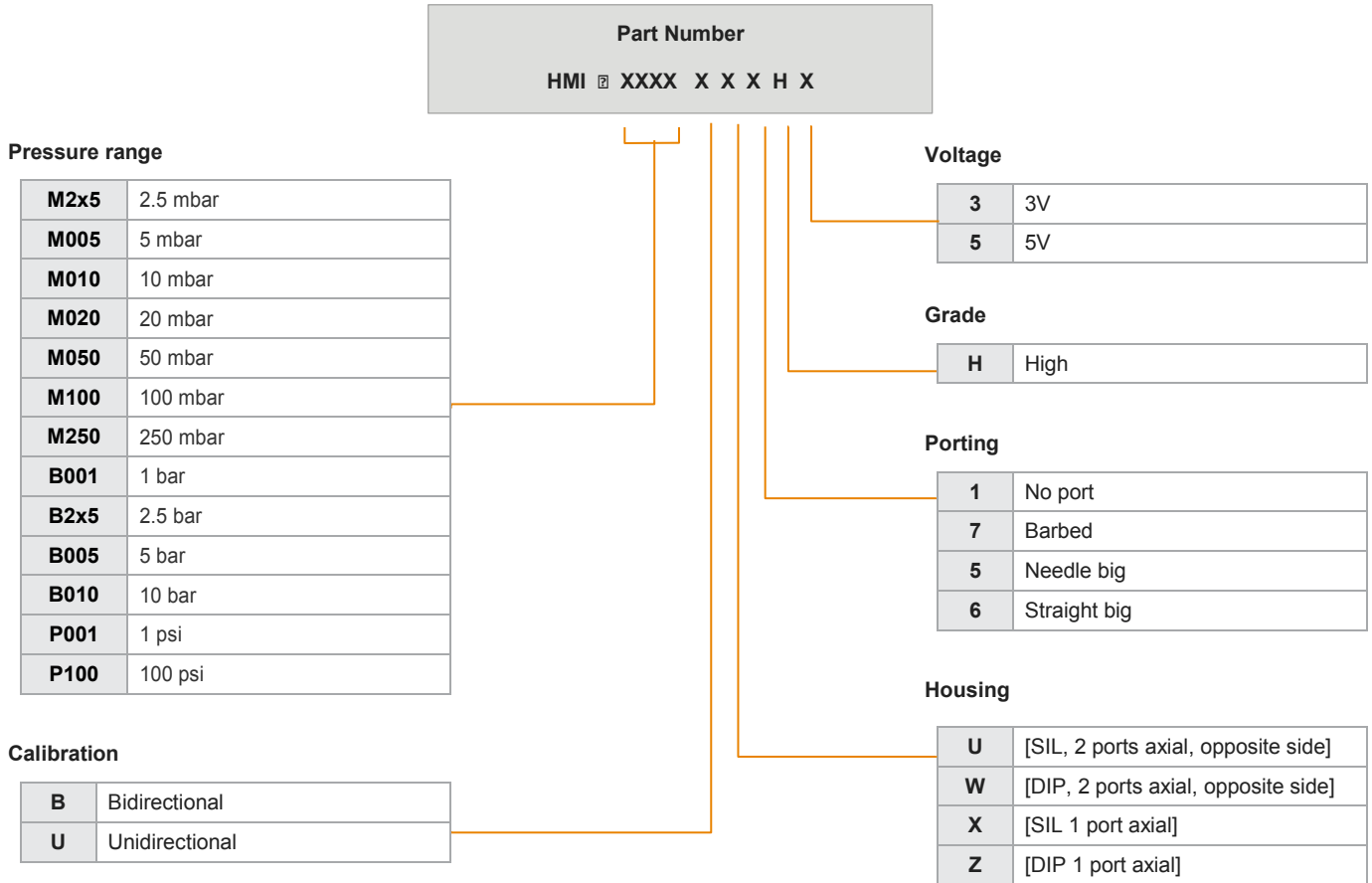

Order code example: HMIB001BW1H3

HMI SERIES – AMPLIFIED PRESSURE SENSORS

Label information

Digit	1	2	3	4	5	6	7	8	9	10	11	12	13	14				
	Series			Pressure range		Calibration		Housing		Porting		Grade / voltage		Rev	Date code (year)	Production code		
Char	M	A	HMI	1	2.5 mbar	U	Unidirectional	U	SIL, 2 ports axial, opposite side	1	no port	-	High, 5 V					
				2	5 mbar					7	Barbed	/	High, 3 V					
				3	10 mbar	B	Bidirectional	W	DIP, 2 ports axial, opposite side	5	Needle big							
				4	20 mbar					6	Straight big							
				5	50 mbar			X	SIL, 1 port axial									
				6	1 psi			Z	DIP; 1 port axial									
				7	100 mbar													
				8	250 mbar													
				A	1 bar													
				B	2.5 bar													
				C	5 bar													
				L	100 psi													
				M	10 bar													

Ordering information (standard configurations)

Description	TE Part Number	Pressure Range	Calibration	Housing	Porting	Grade	Voltage
HMIM100BW1H3	2003783-F	100 mbar	Bidirectional	DIP, 2 ports axial, opposite side	No port	High	3 V
HMIB001BZ7H3	2003556-F	1 bar	Bidirectional	DIP 1 port axial	Barbed	High	3 V
HMIB2X5UZ7H3	2003626-F	2.5 bar	Unidirectional	DIP 1 port axial	Barbed	High	3 V
HMIB005UX5H3	2003831-F	5 bar	Unidirectional	SIL 1 port axial	Needle big	High	3 V
HMIB010UU1H3	2003723-F	10 bar	Unidirectional	SIL, 2 ports axial, opposite side	No port	High	3 V

Note:

The above product listings are examples of possible product configurations. More standard product configurations are available on request.

In addition, custom specific pressure and temperature ranges as well as mechanical or electronic sensor modifications are widely available.

Please note, not all possible sensor configurations are active products. MOQ may apply. Please contact your local sensors representative to learn more.