

LOC	DIST	REVISIONS					
		P	LYN	DESCRIPTION	DATE	DWN	APVD
GP	00	D		REVISED PER ECO-12-003841	14MAR2012	TY	KS
		E		REVISED PER ECO-12-005533	31MAR2012	JY	AC
		F		REVISED PER ECO-14-017735	30EC2014	RG	MC

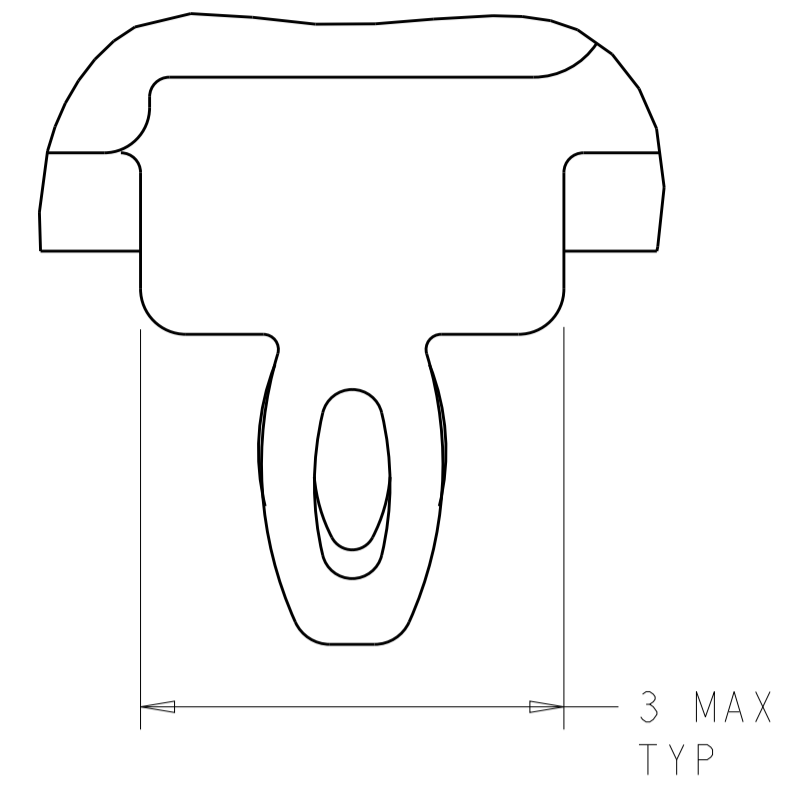

DETAIL S
 SCALE 20:1 $\triangle 13$

- $\triangle 1$ CAGE ASSEMBLY MATERIAL: NICKEL SILVER, 0.25 THICK
 HEAT SINK MATERIAL: ALUMINUM
 HEAT SINK CLIP MATERIAL: STAINLESS STEEL
 EMI SPRING MATERIAL: COPPER ALLOY
 FRONT FLANGE MATERIAL: ZINC ALLOY
 LIGHT PIPE MATERIAL: CLEAR POLYCARBONATE
- $\triangle 2$ PITCH BETWEEN PORTS OF ONE 1X4 CAGE ASSEMBLY.
- $\triangle 3$ SPACING BETWEEN CAGES ON THE SAME PC BOARD, TO BE SPECIFIED BY CUSTOMER, MUST COMPLY WITH MINIMUM DIMENSIONS SHOWN.
- $\triangle 4$ REFERENCE APPLICATION SPEC 114-13218 FOR RECOMMENDED DRILL HOLE DIAMETER AND PLATING THICKNESS.
- $\triangle 5$ DATUMS AND BASIC DIMENSIONS ESTABLISHED BY CUSTOMER.
- $\triangle 6$ DIMENSION C IS THE NOMINAL THICKNESS OF CUSTOMER SUPPLIED PC BOARD,
 SINGLE SIDED PC BOARD MINIMUM THICKNESS = 1.45mm
 DOUBLE SIDED PC BOARD MINIMUM THICKNESS = 2.2mm PER QSFP.
- $\triangle 7$ HEAT SINKS, LIGHT PIPES, AND CLIP SHIPPED ASSEMBLED TO CAGE ASSEMBLY.
 CAGE ASSEMBLY MAY BE PRESSED INTO THE PCB AS SHIPPED.
- $\triangle 8$ DATUM \square -A- IS TOP SURFACE OF PC BOARD.
- $\triangle 9$ DIMENSION APPLIES WITH MODULE INSERTED IN CAGE.
- $\triangle 10$ UNPLATED THRU HOLE.
- $\triangle 11$ MAXIMUM HEIGHT OF LED OFF BOARD: 0.9mm.
- 12. MATES WITH QSFP MSA COMPATIBLE TRANSCEIVER.
- $\triangle 13$ SURFACE TRACES PERMITTED WITHIN THIS AREA EXCEPT WHERE CAGE STANDOFFS, SHOWN IN DETAIL S, CONTACT PC BOARD.
- $\triangle 14$ BASELINE FOR THESE DIMENSIONS IS THE CENTER OF COMPLIANT PIN HOLE.

- $\triangle 15$ 2D BARCODE AND DATE CODE (YYWW) MARKED ON SIDE OF CAGE ASSEMBLY.
- $\triangle 16$ REFERENCE APP SPEC 114-13218 FOR GASKET THICKNESS CALCULATION.
- $\triangle 17$ EMI SPRING FINISH: 2 μ m MINIMUM TIN
 FRONT FLANGE FINISH: 3 μ m MINIMUM TIN OVER 1.27 μ m MINIMUM NICKEL
 OVER 5.08 μ m MINIMUM COPPER
 HEAT SINK FINISH: NICKEL.
- $\triangle 18$ HEAT SINKS AND CLIPS SHIPPED ASSEMBLED TO CAGE ASSEMBLY. CAGE ASSEMBLY MAY BE PRESSED INTO THE PCB AS SHIPPED. LIGHT PIPES, SHIPPED UNATTACHED, MUST BE ASSEMBLED BY CUSTOMER AFTER THE CAGE IS SEATED IN THE PCB.

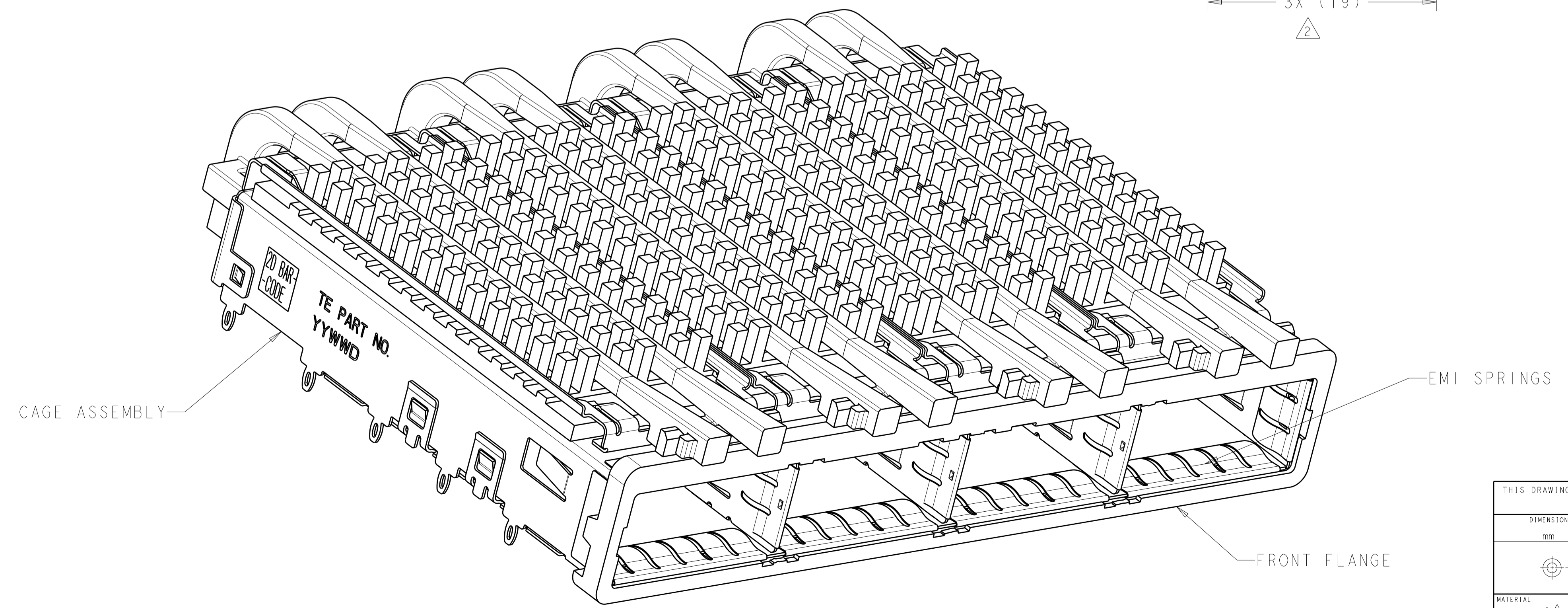
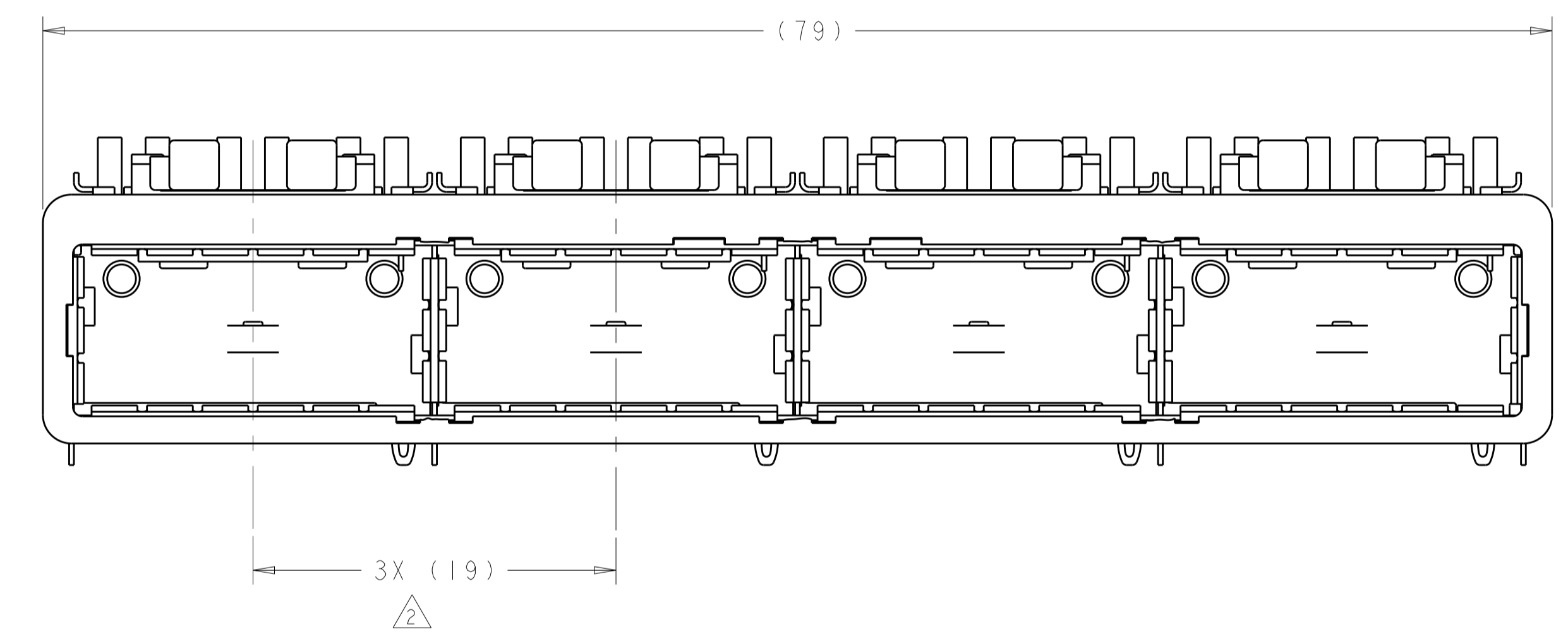
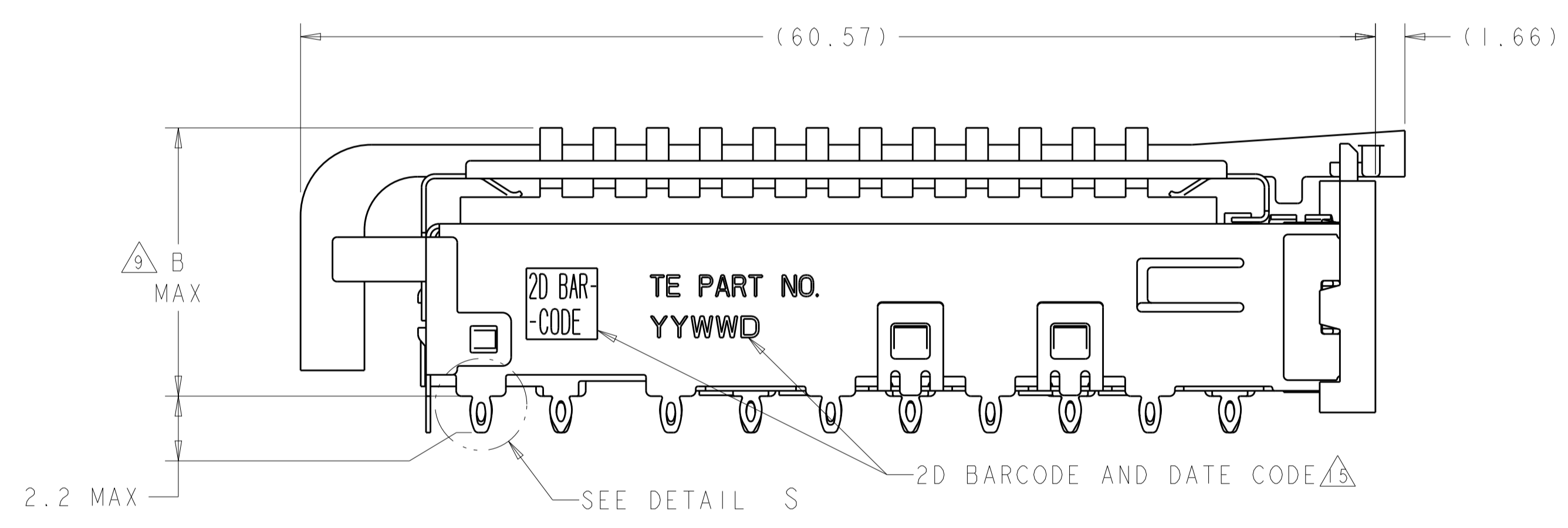

$\triangle 18$	13.7	PCI	2007626-3
$\triangle 7$	23.0	NETWORKING	2007626-2
$\triangle 7$	16.0	SAN	2007626-1
B		HEAT SINK PROFILE	PART NUMBER

THIS DRAWING IS A CONTROLLED DOCUMENT.		DWN C. VALENTINI 28FEB2008	NAME 1X4 CAGE ASSEMBLY, BEHIND BEZEL, W/ SQUARE LIGHT PIPES AND HEAT SINKS, QSFP
DIMENSIONS:		CHK E. BRIGHT 28FEB2008	RESTRICTED TO
mm	0 PLC \pm	APVD F. BRIGHT 28FEB2008	SIZE A1
	1 PLC ± 0.1	PRODUCT SPEC	CAGE CODE 00779
	2 PLC ± 0.1	108-2286	DRAWING NO C=2007626
	3 PLC \pm	APPLICATION SPEC	SCALE 1:1
	4 PLC \pm	WEIGHT	SHEET 1 OF 5
	ANGLES \pm	CUSTOMER DRAWING	REV F
	FINISH $\triangle 17$		

LOC	DIST	REVISIONS					
GP	00	P.	LYR	DESCRIPTION	DATE	DWN	APVD
-	-	-	-	SEE SHEET 1	-	-	-

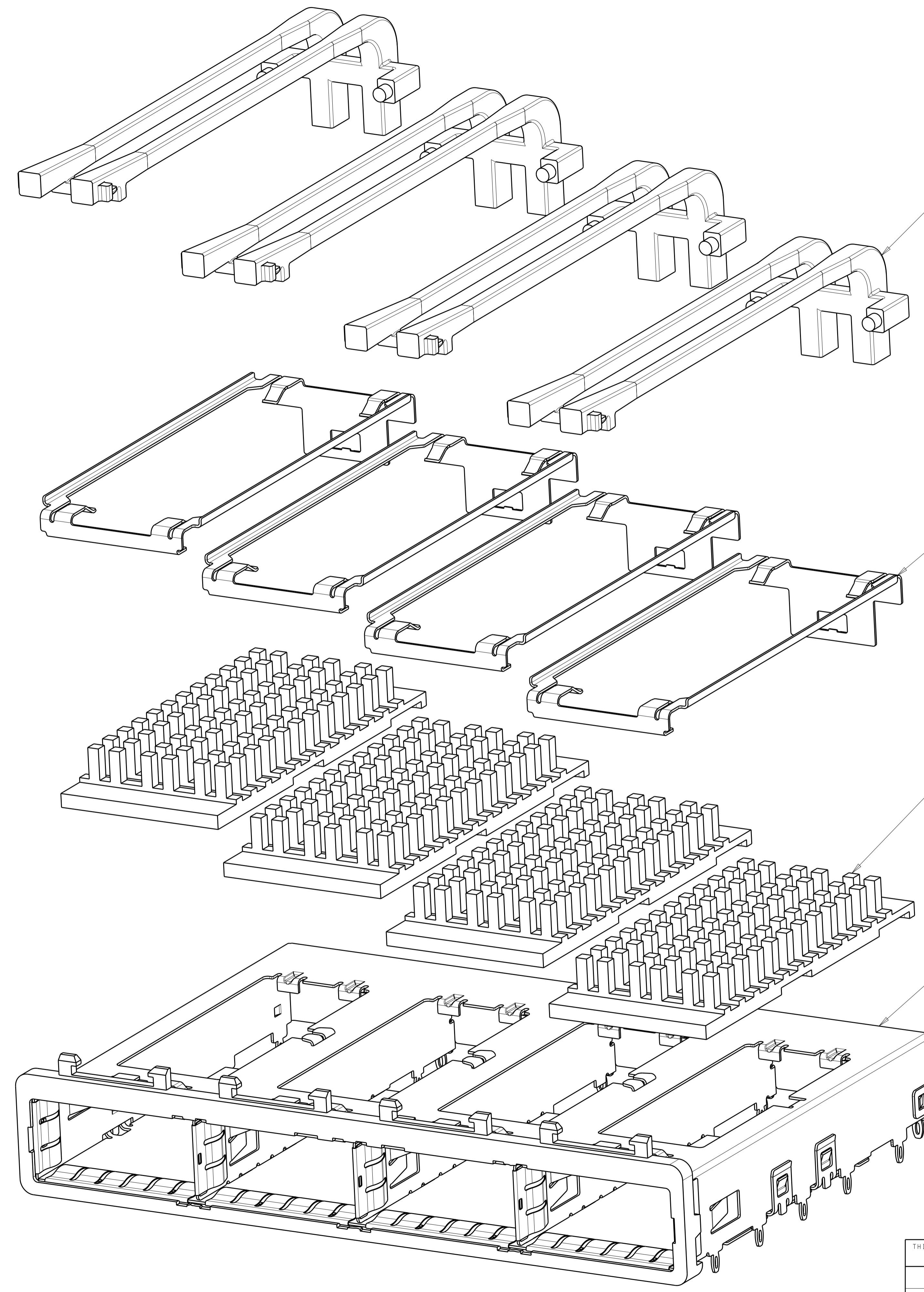

SQUARE DOUBLE LIGHT PIPES $\triangle 7/18$
 QUANTITY: 4

HEAT SINK CLIPS $\triangle 7/18$
 QUANTITY: 4

72 PIN HEAT SINKS $\triangle 7/18$
 QUANTITY: 4

1X4 BEHIND BEZEL QSFP
 CAGE ASSEMBLY
 QUANTITY: 1

THIS DRAWING IS A CONTROLLED DOCUMENT.		DWN	C. VALENTIN	28FEB2008	TE Connectivity	
		CHK	E. BRIGHT	28FEB2008		
		APVD	F. BRIGHT	28FEB2008	NAME 1X4 CAGE ASSEMBLY, BEHIND BEZEL, W/ SQUARE LIGHT PIPES AND HEAT SINKS, QSFP	
		PRODUCT SPEC	108-2286	APPLICATION SPEC		
		SIZE	A1	CAGE CODE	DRAWING NO	RESTRICTED TO
		WEIGHT	-	C=2007626	-	-
		CUSTOMER DRAWING	-	SCALE	1:1	SHEET 2 OF 5
		REV	F			

LOC	DIST	REV	DATE	BY	APPV
GP	00				
REVISIONS			DESCRIPTION	DATE	BY
			SEE SHEET 1		

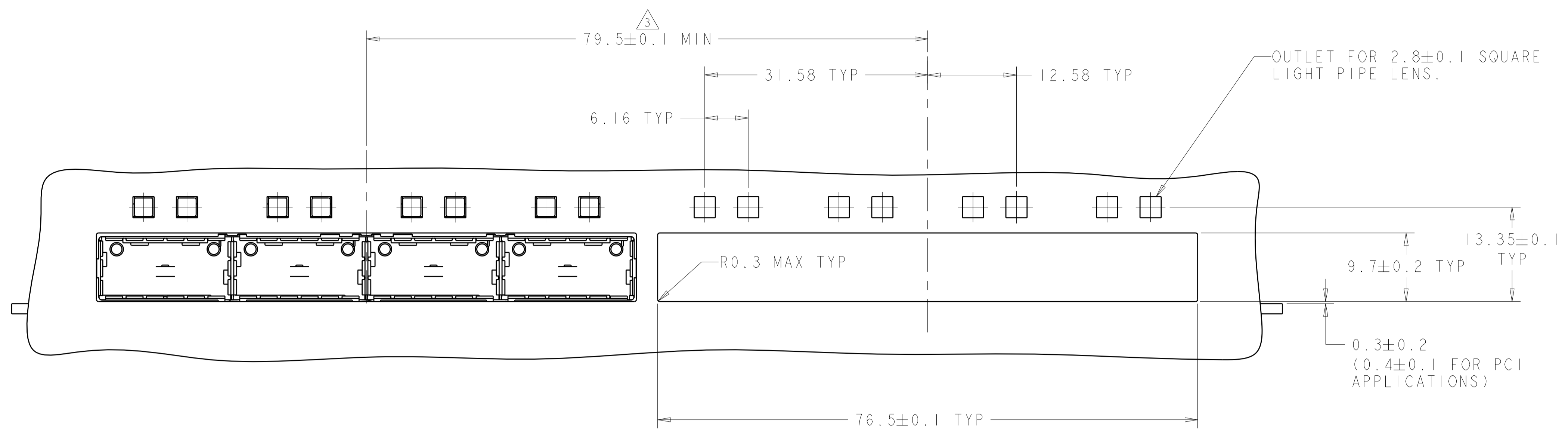

ONE SIDED CONFIGURATION
 SCALE 5:2

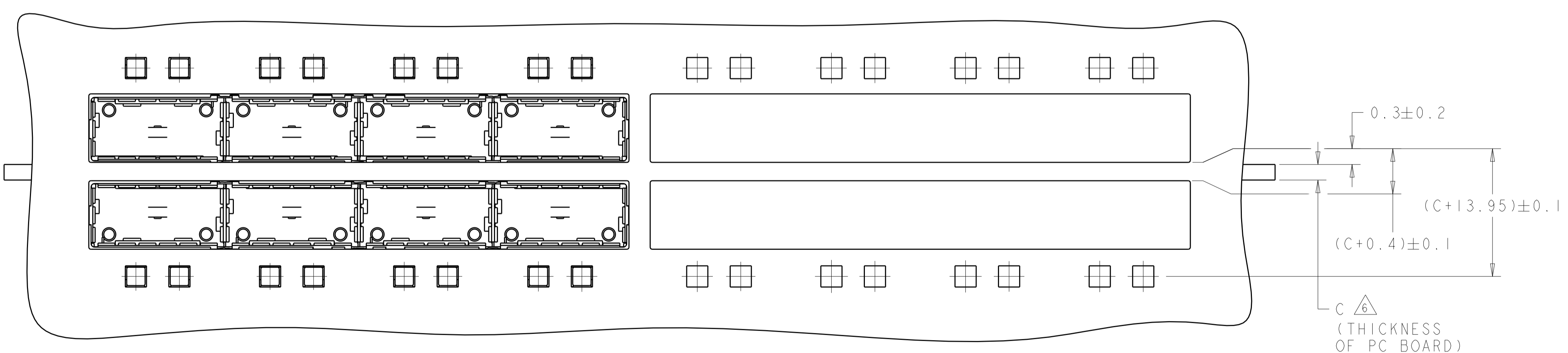
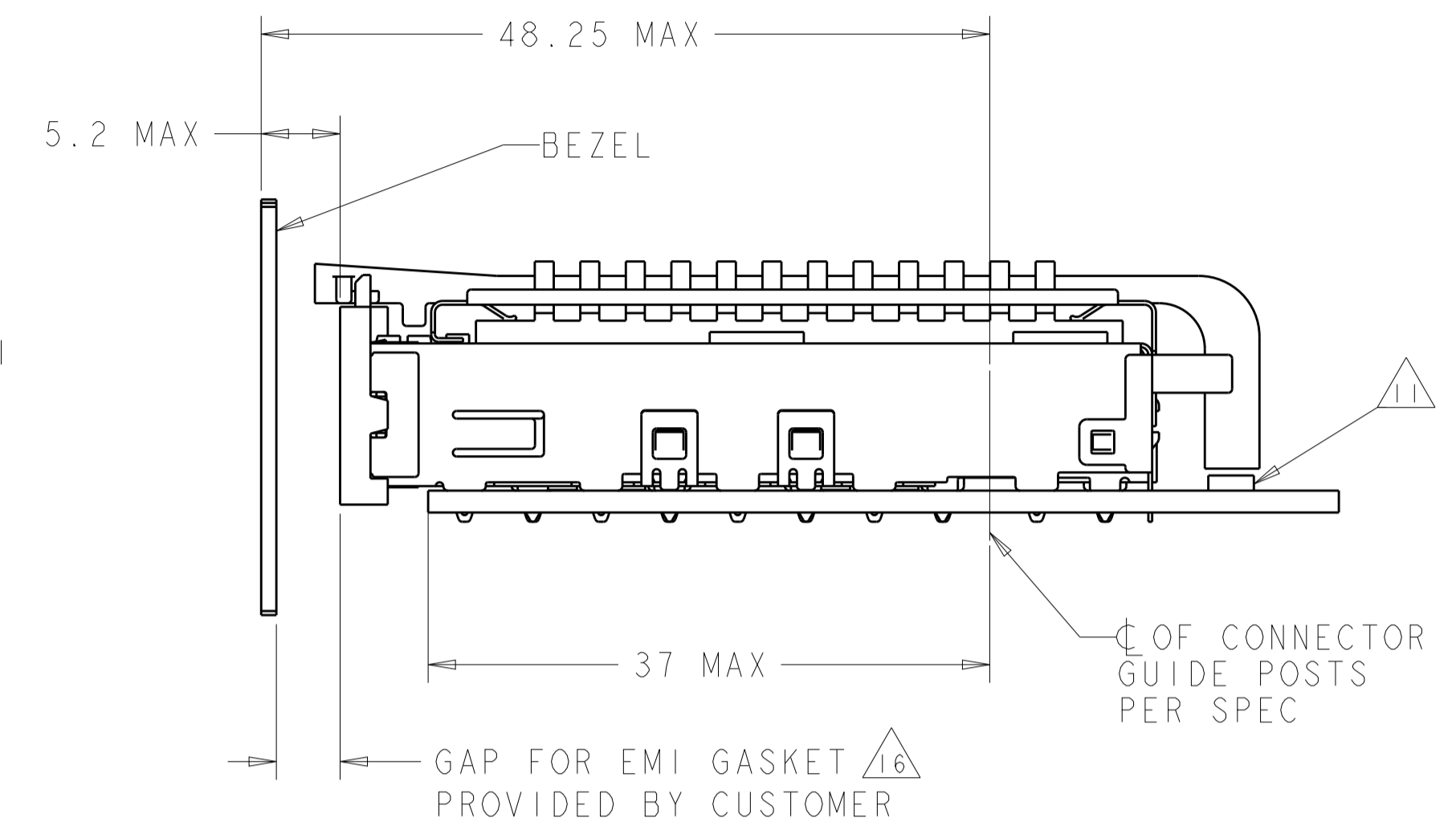

BELLY TO BELLY CONFIGURATION
 SIMILAR TO ONE SIDED
 EXCEPT WHERE NOTED
 SCALE 5:2

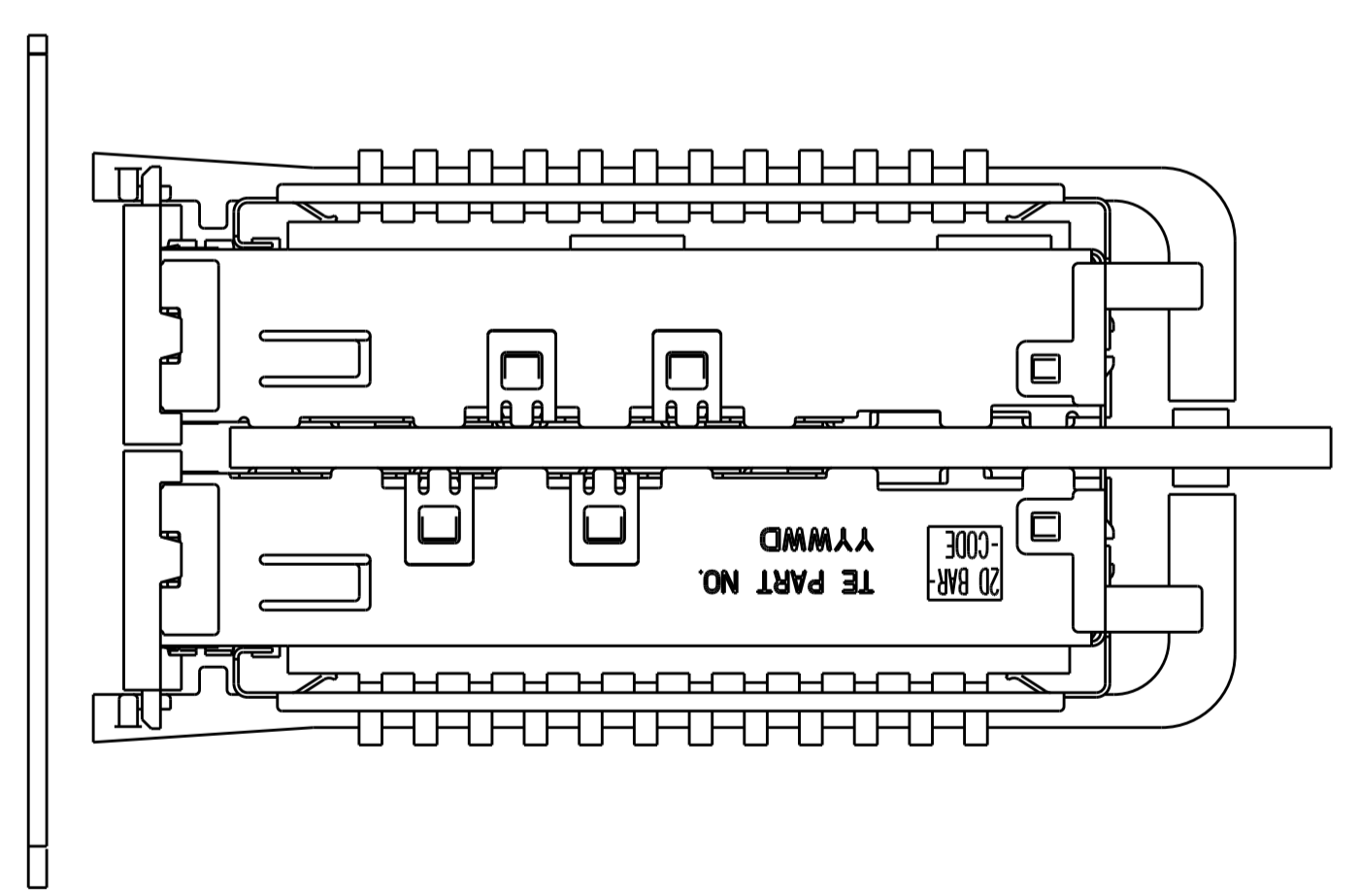

THIS DRAWING IS A CONTROLLED DOCUMENT.		OWN C. VALENTINI 28FEB2008	TE Connectivity NAME 1X4 CAGE ASSEMBLY, BEHIND BEZEL, W/ SQUARE LIGHT PIPES AND HEAT SINKS, QSFP
DIMENSIONS:		CHK E. BRIGHT 28FEB2008	
mm	TOLERANCES UNLESS OTHERWISE SPECIFIED:	APVD E. BRIGHT 28FEB2008	PRODUCT SPEC
0 PLC	±		APPLICATION SPEC
1 PLC	±0.1		SIZE
2 PLC	±0.1		CAGE CODE
3 PLC	±		DRAWING NO
4 PLC	±		RESTRICTED TO
ANGLES	±		A100779C=2007626
MATERIAL	FINISH	WEIGHT	SCALE 4:1 SHEET 3 OF 5 REV F
CUSTOMER DRAWING			

LOC	DIST	REV	DESCRIPTION	DATE	OWN	APVD
GP	00		SEE SHEET 1			

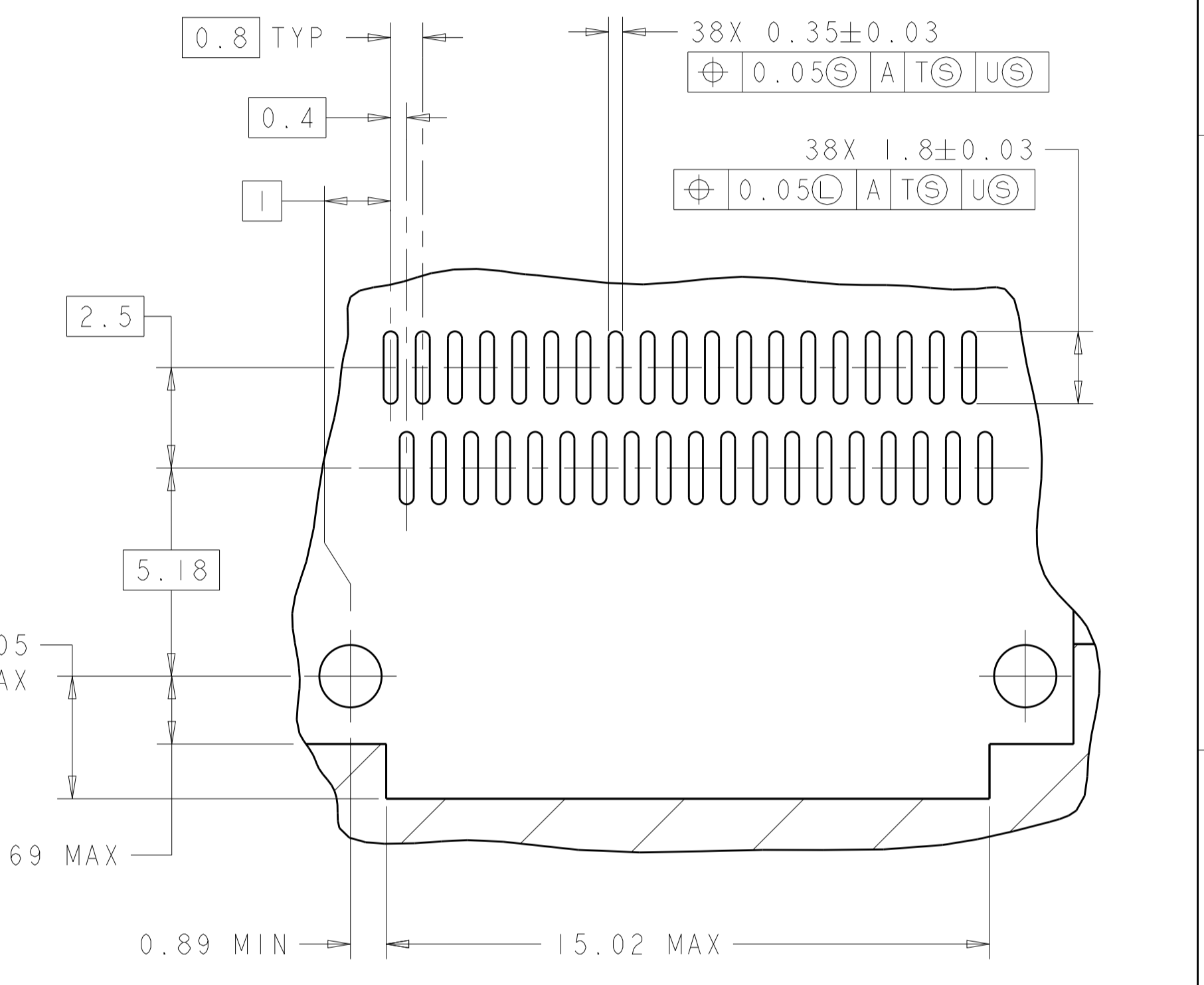
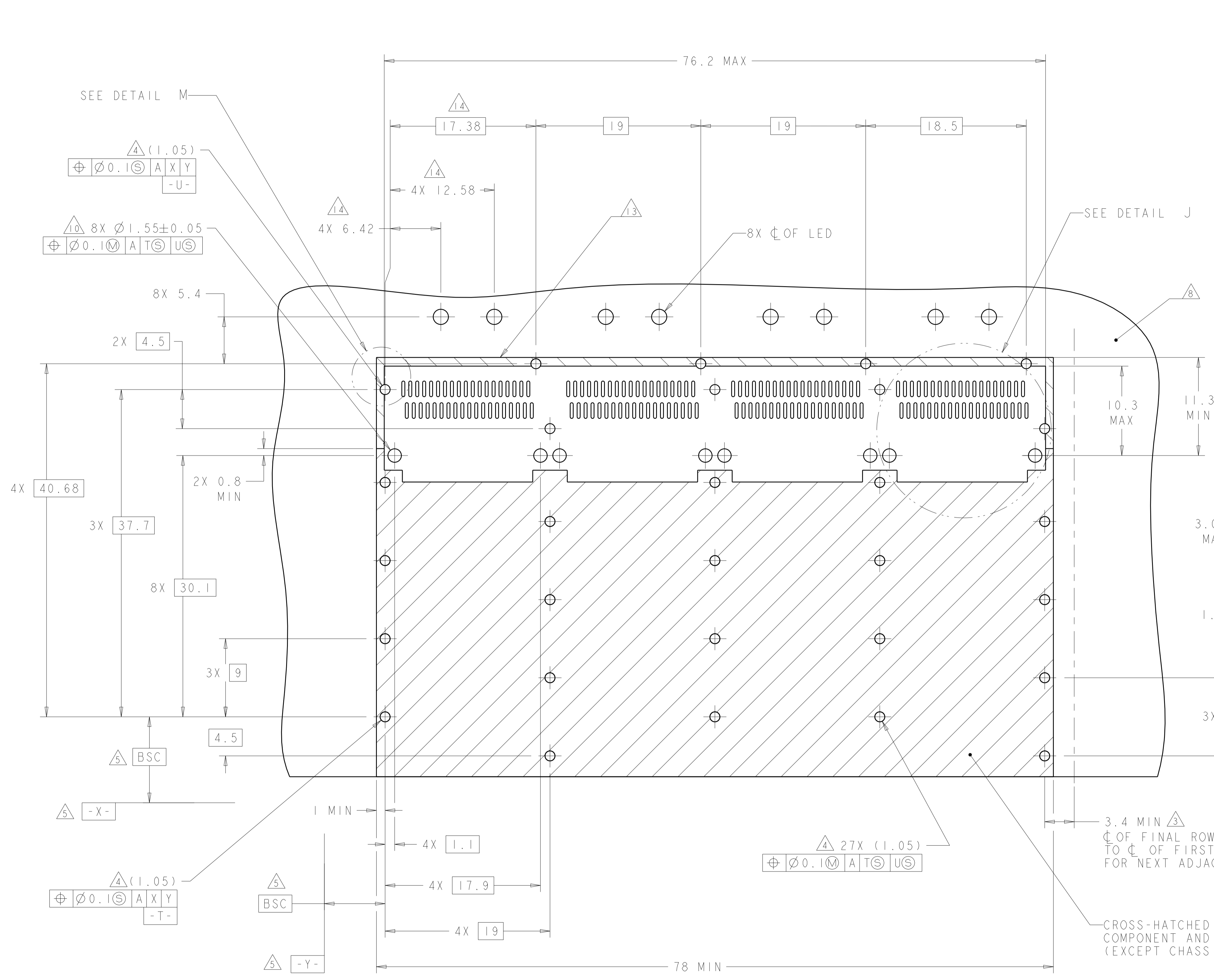

RECOMMENDED PC BOARD LAYOUT
 SINGLE SIDE MOUNT CONFIGURATION
 SCALE 4:1

3.4 MIN Δ
 ϕ OF FINAL ROW OF HOLES
 TO ϕ OF FIRST ROW OF HOLES
 FOR NEXT ADJACENT CAGE

CROSS-HATCHED AREA DENOTES
 COMPONENT AND TRACE KEEP-OUT
 (EXCEPT CHASSIS GROUND)

THIS DRAWING IS A CONTROLLED DOCUMENT.		OWN C. VALENTINE 28FEB2008	TE Connectivity
DIMENSIONS: mm		CHK E. BRIGHT 28FEB2008	
TOLERANCES UNLESS OTHERWISE SPECIFIED:		APVD E. BRIGHT 28FEB2008	NAME 1X4 CAGE ASSEMBLY, BEHIND BEZEL, W/ SQUARE LIGHT PIPES AND HEAT SINKS, QSFP
0 PLC	\pm	PRODUCT SPEC	SIZE 108-2286
1 PLC	± 0.1	APPLICATION SPEC	RESTRICTED TO
2 PLC	± 0.1	WEIGHT	A100779C=2007626
3 PLC	\pm	CUSTOMER DRAWING	SCALE 1:1 SHEET 4 OF 5 REV F
4 PLC	\pm		
ANGLES	\pm		
MATERIAL	FINISH		