

202 SERIES

3-Phase Voltage/Phase Monitor

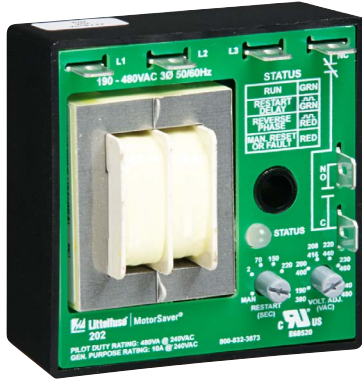

Wiring Diagram

202 WITH MOTOR CONTROL

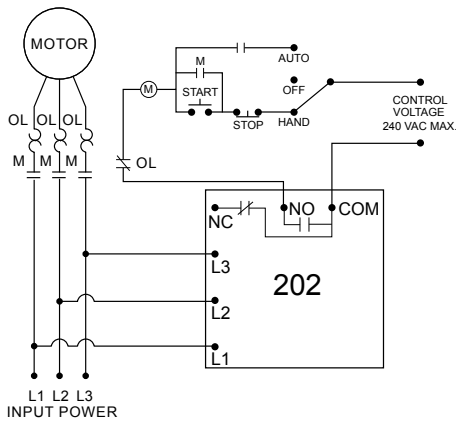

202 WITH ALARM CIRCUIT

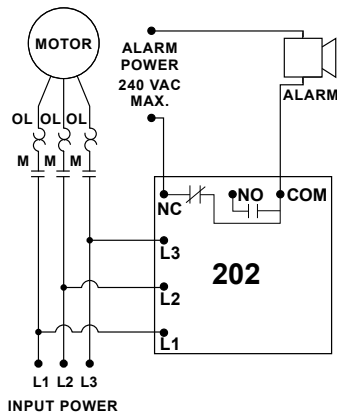

Description

The 202 series is a 3-phase, auto-ranging, dual-range voltage monitor that protects 190–480 V ac, 50*/60 Hz motors regardless of size. The 202-RP (and the 202-575-RP for 475–600 V ac) monitors the phase rotation of 3-phase systems and trips on reverse-phase only. Critical applications include fan motors, scroll compressors, grinders, conveyor systems, elevators and escalators. Both products provide a user selectable nominal voltage setpoint and automatically select between the 200 V and 400 V range.

This unique microcontroller-based voltage and phase-sensing device constantly monitors the 3-phase voltages to detect harmful power line conditions. When a harmful condition is detected, the MotorSaver's output relay is deactivated after a specified trip delay. The output relay reactivates after power line conditions return to acceptable levels for a specified amount of restart delay time (or a manual reset). The 202 series includes advanced single LED diagnostics. Five different light patterns distinguish between faults and normal conditions. The status light turns green and the relay is activated when rotation is correct.

Features & Benefits

FEATURES	BENEFITS
Compact, quick mounting design	1-screw mounting saves time and space. Small footprint ideal for assembly into panels.
Proprietary microcontroller based circuitry	Constant monitoring of single-phase, low voltage, high voltage, voltage unbalance, phase reversal, harmful power line conditions.
Auto-sensing wide voltage range (202 & 202-RP)	Automatically senses system voltage between 90–480 V ac. Saves setup time.
Advanced LED diagnostics	Quick visual indicator for cause of trip. LED indications include: normal operation, restart delay, reverse-phase trip, fault
Adjustable trip delay (202)	Prevent nuisance tripping due to rapidly fluctuating power line conditions.

Ordering Information

MODEL	LINE VOLTAGE	DESCRIPTION
202	190–480 V ac	Standard protection with low/high voltage trip, voltage unbalance
202-RP	190–480 V ac	Trips on reverse-phase only
202-575-RP	475–600 V ac	Designed for higher voltage systems and trips on reverse-phase only

202 SERIES

Specifications

Frequency	50*/60 Hz
Functional Characteristics	
Phase Sequence	ABC
Low Voltage (% of setpoint)	
Trip	90 %
Reset	93 %
High Voltage (% of setpoint)	
Trip	110 %
Reset	107 %
Voltage Unbalance (NEMA)	
Trip	6 %
Reset	4.5 %
Trip Delay Time	
High and Low Voltage	4 seconds
Unbalance & Phasing Faults	2 seconds
Restart Delay Time	
After a Fault	Manual, 2–300 seconds adj.
After a Complete Power Loss	Manual, 2–300 seconds adj.

Output Characteristics

Output Contact Rating (SPDT)	
Pilot Duty	480 VA @ 240 V ac
General Purpose	10 A @ 240 V ac
General Characteristics	
Temperature Range	-40° to 70°C (-40° to 158°F)
Trip & Reset Accuracy	±1 %
Repeatability	±0.5 %
Maximum Input Power	5 W
Relative Humidity	95 %, non-condensing
Transient Protection	IEC 61000-4-5, ±4 kV
Hi-potential Test	Meets UL 508 (2x rated V+1000 V for 1 minute)
Termination	0.25" male quick connect

Termination

Safety Marks

UL Recognized

Dimensions

Weight

Mounting Method

UL 508 (File #E68520)
H 63.5 mm (2.5"); W 63.5 mm (2.5");
D 35.56 mm (1.4")
0.5 lb. (8 oz., 226.8 g)
1/4" socket head cap screw (customer supplied)

*Note: 50 Hz will increase all delay timers by 20 %. CE Pending