

© 1968 BY AMP INCORPORATED. ALL RIGHTS RESERVED. AMP PRODUCTS COVERED BY PATENTS AND/OR PATENTS PENDING.

REVISIONS			
	DESCRIPTION	DATE	APPD
01	REV. PER ECN C-433	8-31-73	CMS
A	REV. PER G-322	7/10/77	EMT
B	REV. / ECN G-627	10-26-79	EMT
C	REV. PER ECN R-246	2-2-74	EMT
D	REV. PER ECN R-3030	7-27-87	EMT

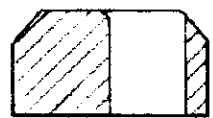
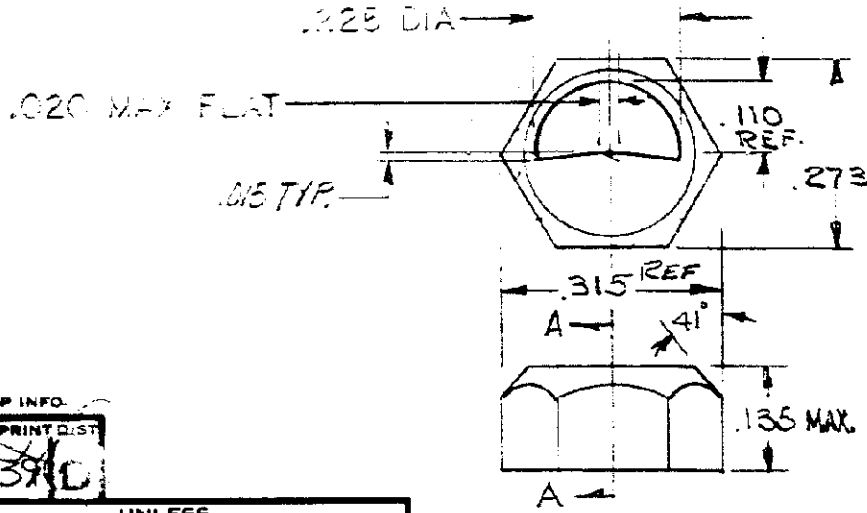

SECT. A-A.

AMP INFO  
 LOC PRINT DIST  
 R 3910

UNLESS OTHERWISE SPECIFIED  
 DIMENSIONS ARE IN INCHES  
 TOLERANCES ON  
 FRACTIONS DECIMALS ANGLES  
 ± .005 ± .005 ± 2°  
 MATERIAL  
 ALUMINUM ALLOY  
 HEAT TREAT  
 FINISH YELLOW CHROMATE  
 OVER CAD PLATE

203758-2 AS SHOWN

SIGNATURE	DATE
DR <i>R. M. ...</i>	4-15-69
CHK <i>R. M. ...</i>	4-24-69
DSGN ENGR <i>R. M. ...</i>	4-24-69
APPD <i>R. M. ...</i>	4/24/69

**AMP** AMP INCORPORATED  
 HARRISBURG, PENNSYLVANIA

NAME  
 KEYING INSERT

DSGN APPD	CODE IDENT NO	SIZE	NUMBER
OTHER APPD	00779	A	203758
SCALE 4-1	WT	CALC	ACTUAL
			SHEET 1 OF 1