



Features

- Compact size: 6 mm diameter, 8 mm length
- Low capacitance and insertion loss
- Switch-Grade Fail-Short option available
- RoHS compliant*
-  UL Recognized

Applications

- Telecommunications equipment
- Industrial equipment/electronics
- Consumer electronics

2056 Series Light Duty 3-Electrode Gas Discharge Tube

Characteristics

Test Methods per ITU-T K.12 and IEC 61643-311.

Characteristic	Model No.				
	2056-09	2056-14	2056-20	2056-23	2056-25
DC Sparkover $\pm 20\%$ @ 100 V/s	90 V	145 V	200 V	230 V	250 V
Impulse Sparkover ⁽¹⁾					
100 V/ μ s	< 750 V	< 750 V	< 600 V	< 600 V	< 600 V
1000 V/ μ s	< 850 V	< 850 V	< 700 V	< 700 V	< 700 V

Characteristic	Model No.				
	2056-35	2056-40	2056-42	2056-47	2056-60
DC Sparkover $\pm 20\%$ @ 100 V/s	350 V	400 V	420 V	470 V	600 V
Impulse Sparkover ⁽¹⁾					
100 V/ μ s	< 650 V	< 700 V	< 700 V	< 800 V	< 900 V
1000 V/ μ s	< 750 V	< 800 V	< 800 V	< 900 V	< 1000 V

⁽¹⁾ Impulse Sparkover voltage is defined as typical values of distribution.

Insulation Resistance (IR) ⁽²⁾	50 / 100 / 250 Vdc	> 1 G Ω
Glow Voltage	10 mA	~ 70 V
Arc Voltage	1 A	~ 10 V
Glow-Arc Transition Current	< 1 A
Maximum Capacitance	1 MHz	< 2 pF
Maximum Impulse Discharge Current	5,000 A, 8/20 μ s	10 operations
Nominal Alternating Discharge Current	5 A, 50 Hz, 1 second	1 operation
Impulse Life	200 A 10/1000 μ s	100 operations
DC Holdover Voltage ⁽³⁾	< 150 ms
Operating Temperature	-30 to +85 °C
Storage Temperature	-40 to +115 °C
Climatic Category (IEC 60068-1)	40 / 90 / 21

Notes:

- UL Recognized component, UL File E153537.
- At delivery AQL 0.65, level II DIN ISO 2859
- Line to Line voltage is approximately 1.8 to 2 times the stated Line to Ground voltage.
- Discharge current rating is total current equally divided between Each Line To Ground (ELTG).

⁽²⁾ DC Sparkover Voltage	IR Measuring Voltage
90 V	50 V
145–400 V	100 V
420–600 V	250 V

⁽³⁾ Network Applied	
DC Sparkover Voltage	DC Holdover Voltage
90–145 V	52 V
200–250 V	135 V
350–600 V	150 V



WARNING Cancer and Reproductive Harm
www.P65Warnings.ca.gov

*RoHS Directive 2015/863, Mar 31, 2015 and Annex.

Specifications are subject to change without notice. Users should verify actual device performance in their specific applications. The products described herein and this document are subject to specific legal disclaimers as set forth on the last page of this document, and at www.bourns.com/docs/legal/disclaimer.pdf

2056 Series Light Duty 3-Electrode Gas Discharge Tube

BOURNS®

Product Dimensions

2056-xx-A

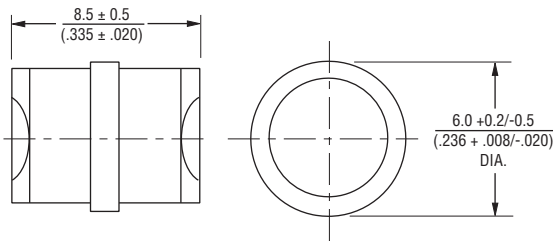

2056-xx-B2

0.8 mm dia., 4.4 mm spacing
(B2FLF Switch-Grade Fail-Short Configuration Shown)

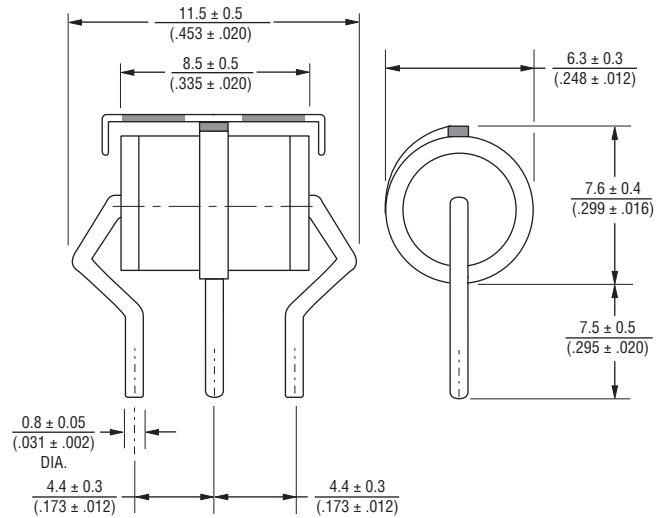

2056-xx-B3

0.8 mm dia., 3.8 mm spacing

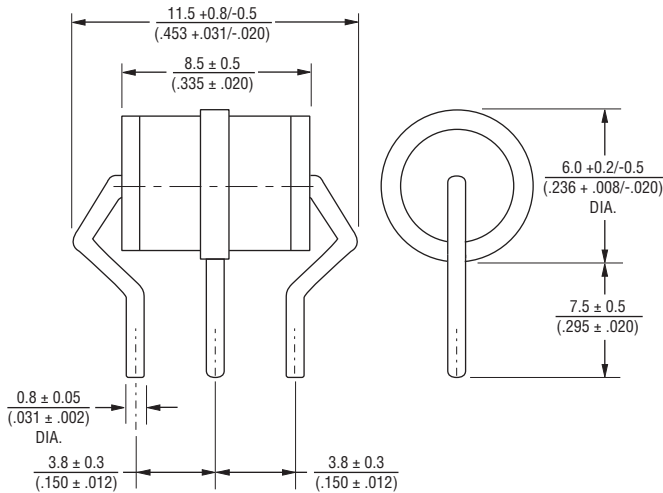

DIMENSIONS: $\frac{\text{MM}}{\text{(INCHES)}}$

How to Order

2056 - xx - xx (F) LF

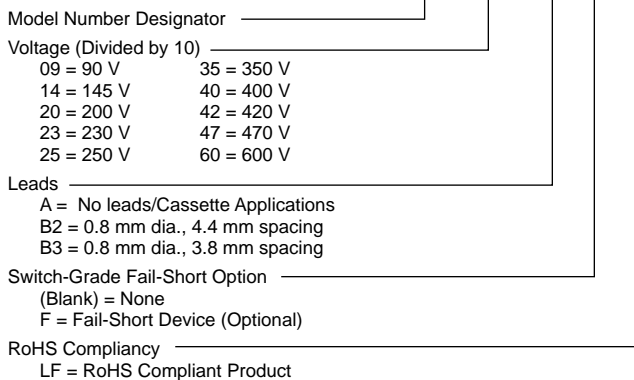

Packaging Specifications

Model 2056 ships standard bulk pack, 100 pieces per tray; 5 trays per box, 2 boxes per outer pack (1K units).

BOURNS®

Asia-Pacific:

Tel: +886-2 2562-4117

Email: asiacus@bourns.com

Europe:

Tel: +36 88 885 877

Email: eurocus@bourns.com

The Americas:

Tel: +1-951 781-5500

Email: americus@bourns.com

www.bourns.com

REV. B 09/19

Specifications are subject to change without notice. Users should verify actual device performance in their specific applications.

The products described herein and this document are subject to specific disclaimers as set forth on the last page of this document, and at www.bourns.com/legal/disclaimer.pdf.