

LOC		DIST		REVISIONS			
GP	00	P	LTR	DESCRIPTION	DATE	DWN	APVD
		A		RELEASE PER ECO-10-025263	14FEB2011	CJV	JTL

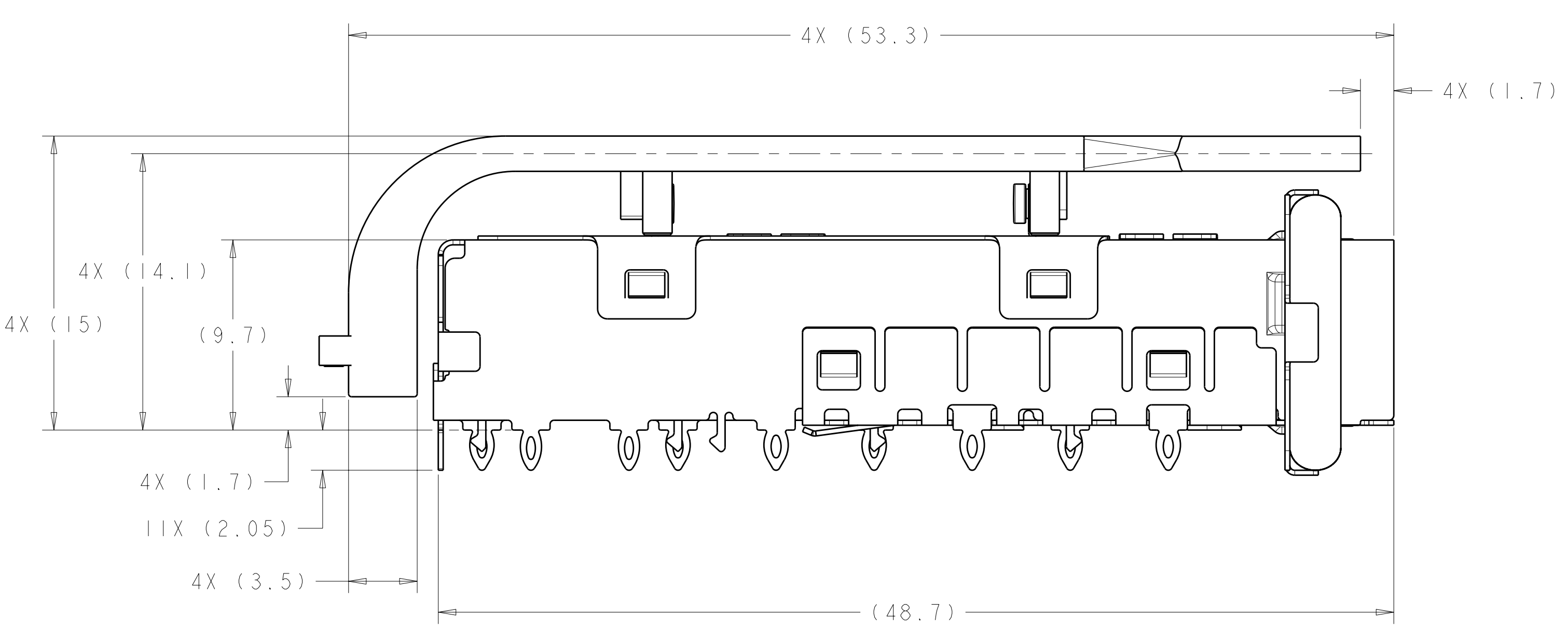

- 1 MATERIAL:
 CAGE ASSEMBLY: NICKEL SILVER ALLOY
 GASKET RETENTION PLATE AND LIGHT PIPE BRACKET: STAINLESS STEEL
 EMI GASKET: PLATED FILLED SILICONE
 LIGHT PIPE: POLYCARBONATE, CLEAR.
- 2 DATUM AND BASIC DIMENSION ESTABLISHED BY CUSTOMER.
- 3. MATES WITH SFP MSA COMPLIANT TRANSCEIVERS.
- 4 PADS AND VIAS CHASSIS GROUND.
- 5. INTERPRETATION OF DATUM REFERENCE FRAME IN ACCORDANCE WITH SECT 4.4.1.1 OF ASME Y14.5M-1994.
- 6 MINIMUM PC BOARD THICKNESS:
 SINGLE SIDED: 1.45mm.
- 7 HOLE PATTERN REPEATS FOR EACH PORT, SPACING BETWEEN PORTS IS 14.25mm.
- 8 REFERENCE APPLICATION SPEC 114-13120, HOLE A, FOR RECOMMENDED DRILL HOLE DIAMETER AND PLATING THICKNESS.
- 9 REFERENCE APPLICATION SPEC 114-13120, HOLE B, FOR RECOMMENDED DRILL HOLE DIAMETER AND PLATING THICKNESS.
- 10 LIGHT PIPE ASSEMBLY SHIPPED UNASSEMBLED TO CAGE ASSEMBLY, CAGE ASSEMBLY TO BE PRESSED INTO THE PC BOARD PRIOR TO ATTACHING THE LIGHT PIPE ASSEMBLY TO THE CAGE ASSEMBLY.

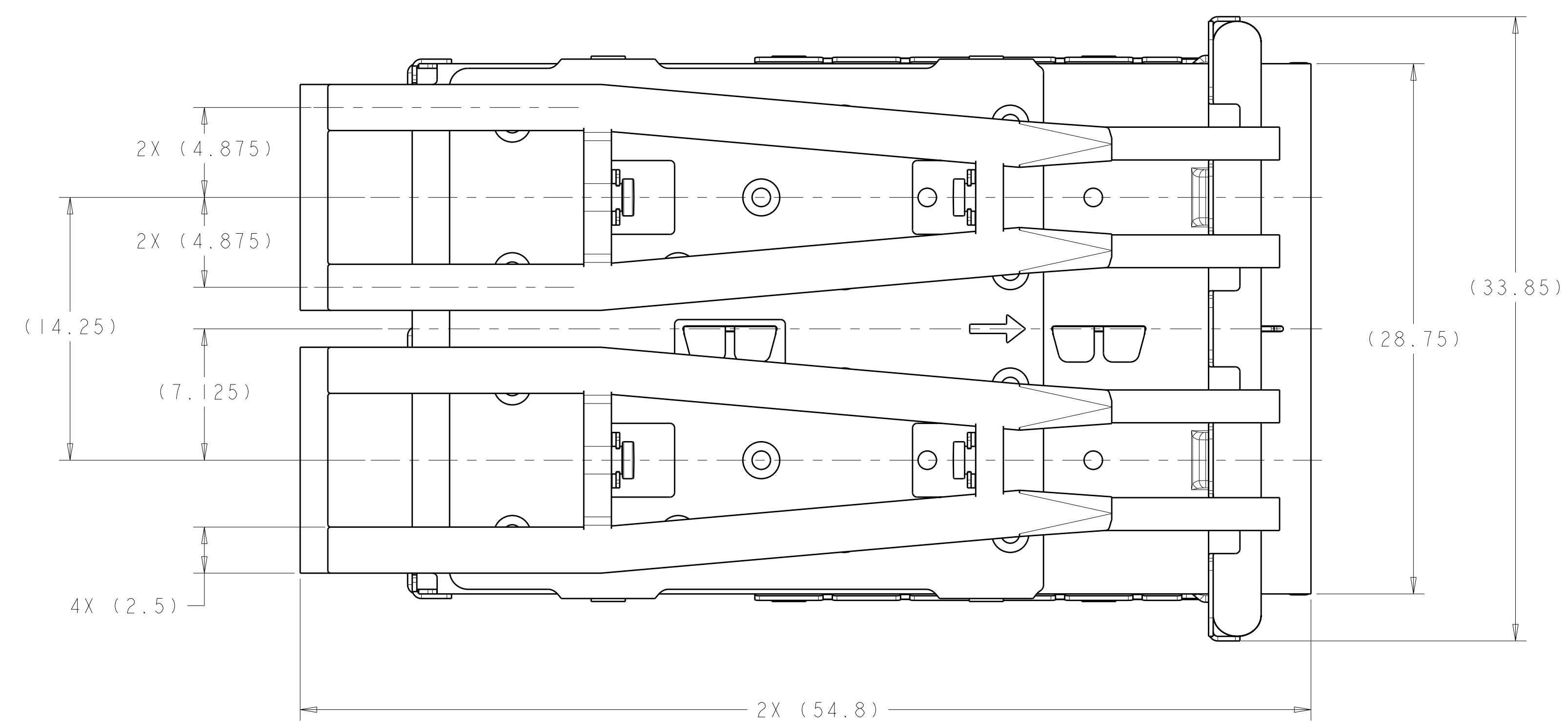
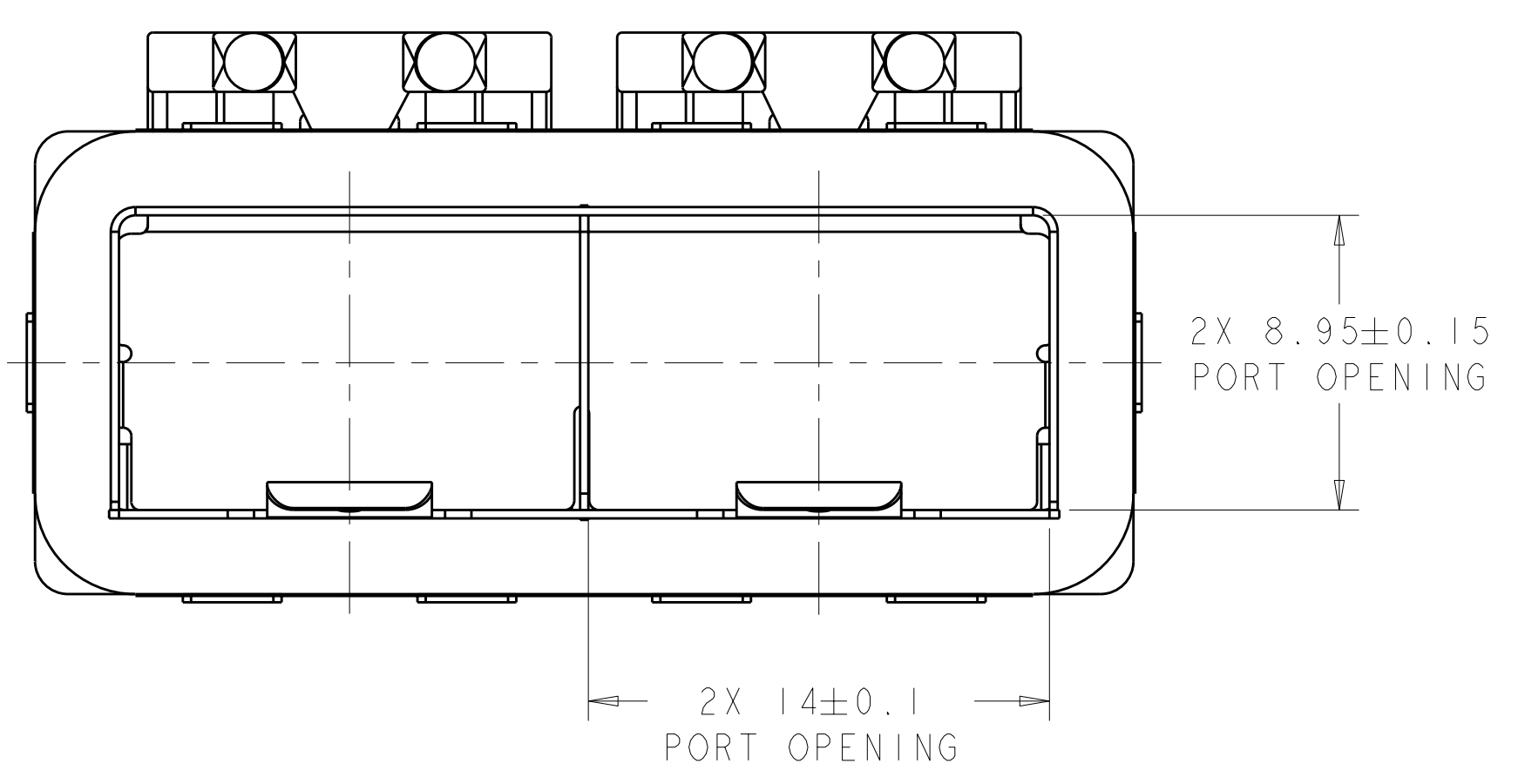
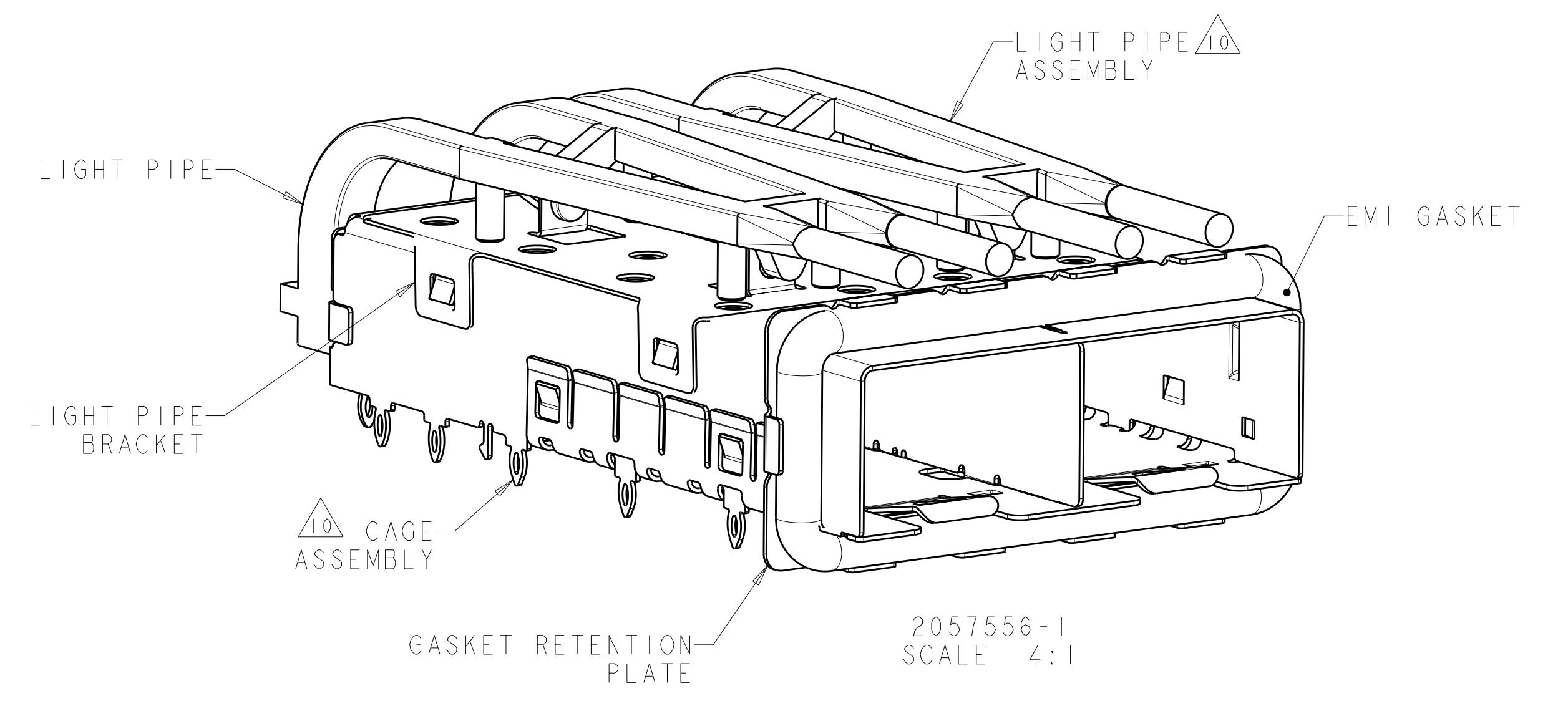

2057556-1
 PART NUMBER

<small>THIS DRAWING IS UNPUBLISHED. RELEASED FOR PUBLICATION BY TYCO ELECTRONICS CORPORATION. ALL RIGHTS RESERVED.</small> <small>THIS IS SUBJECT TO CHANGE WITHOUT NOTICE AND WITHOUT OBLIGATION. TOLERANCES UNLESS OTHERWISE SPECIFIED:</small>		DWN B. MCMASTER 06OCT08 CHK M. SCHMITT 06OCT08 APVD M. SCHMITT 06OCT08	Tyco Electronics Harrisburg, PA 17105-3608
DIMENSIONS: mm 	0 PLC ±0.13 1 PLC ±0.1 2 PLC ±0.08 3 PLC ±0.05 4 PLC ±0.05 ANGLES ±0.05 FINISH #1	NAME SFP+ 1X2 CAGE ASSEMBLY WITH LIGHT PIPES, PRESS FIT, EMI GASKET PRODUCT SPEC - APPLICATION SPEC 114-13120 WEIGHT - CUSTOMER DRAWING	SIZE CAGE CODE DRAWING NO RESTRICTED TO A 100779 C-2057556 SCALE 5:1 SHEET 1 OF 3 REV A

LOC	DIST	REVISIONS					
GP	00	P	LTR	DESCRIPTION	DATE	DWN	APVD
-	-	-	-	SEE SHEET 1	-	-	-

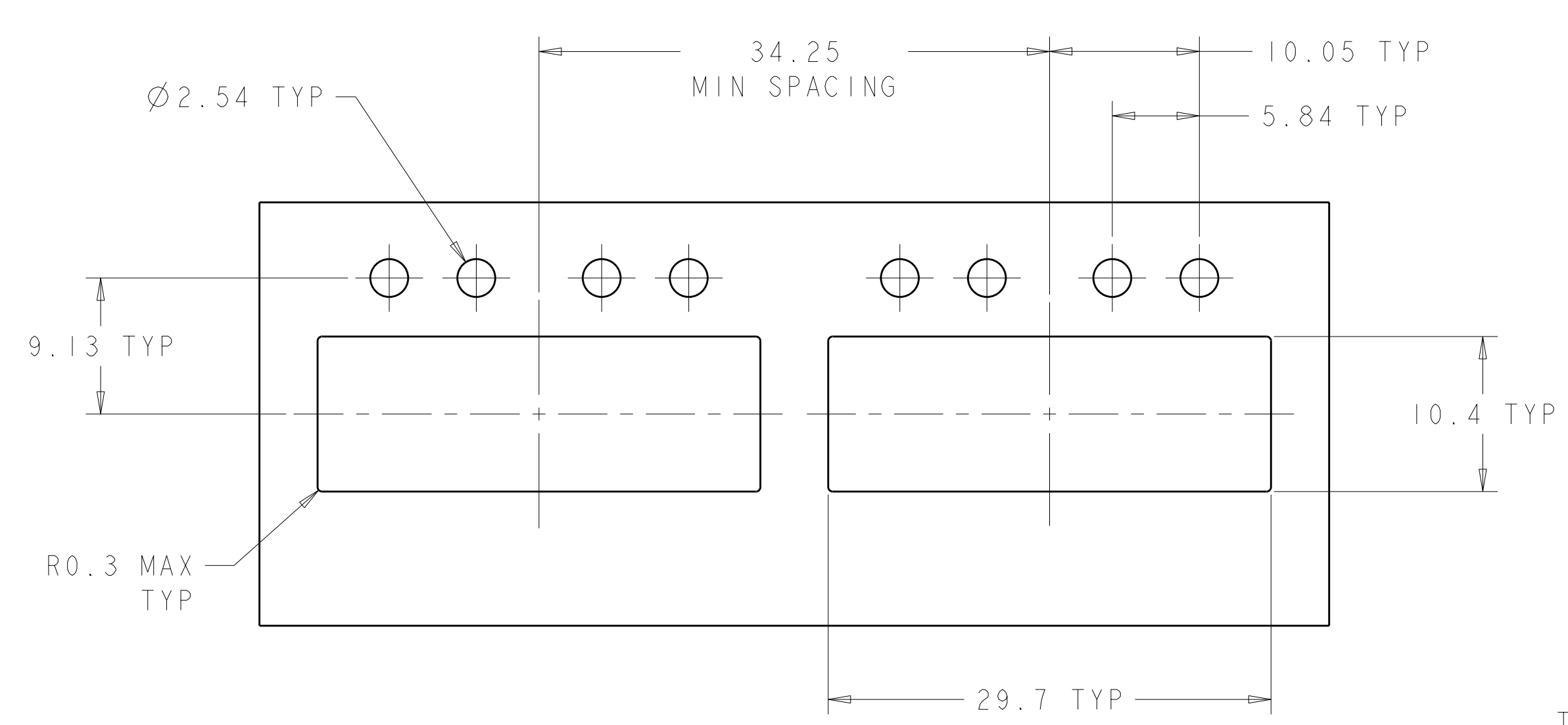

RECOMMENDED BEZEL CUT-OUT
 SCALE 3:1

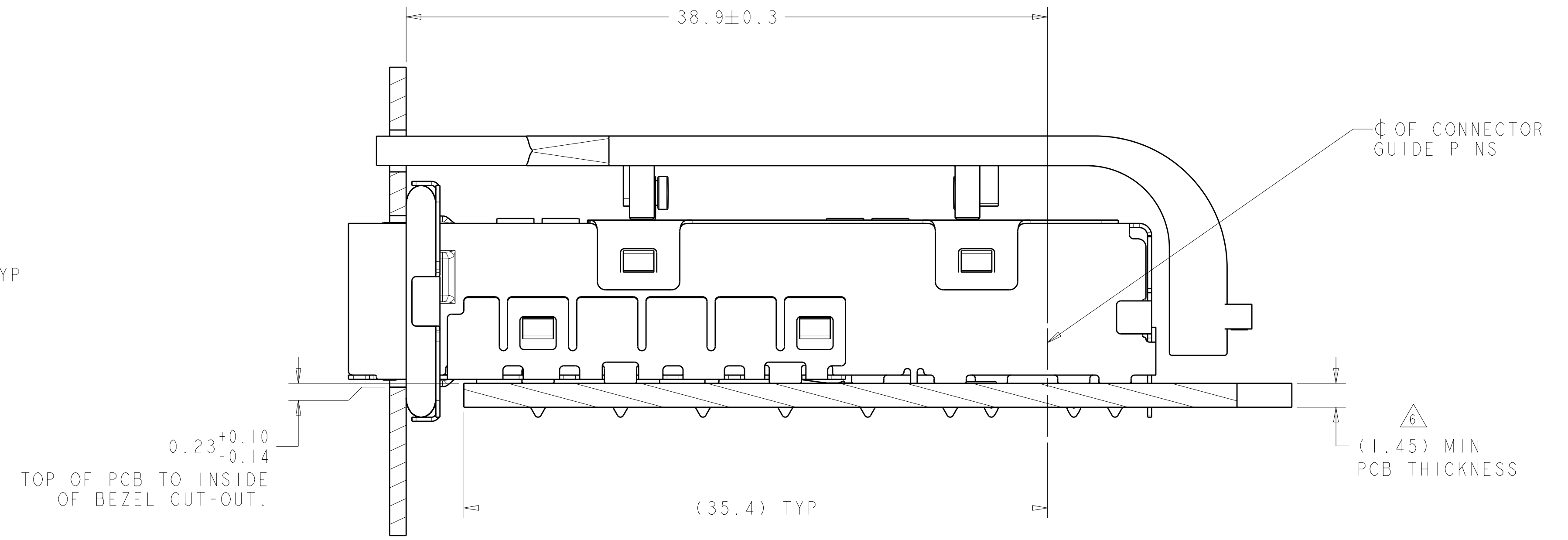

SECTION J-J
 MOUNTED ON PCB
 SHOWN THRU RECOMMENDED BEZEL

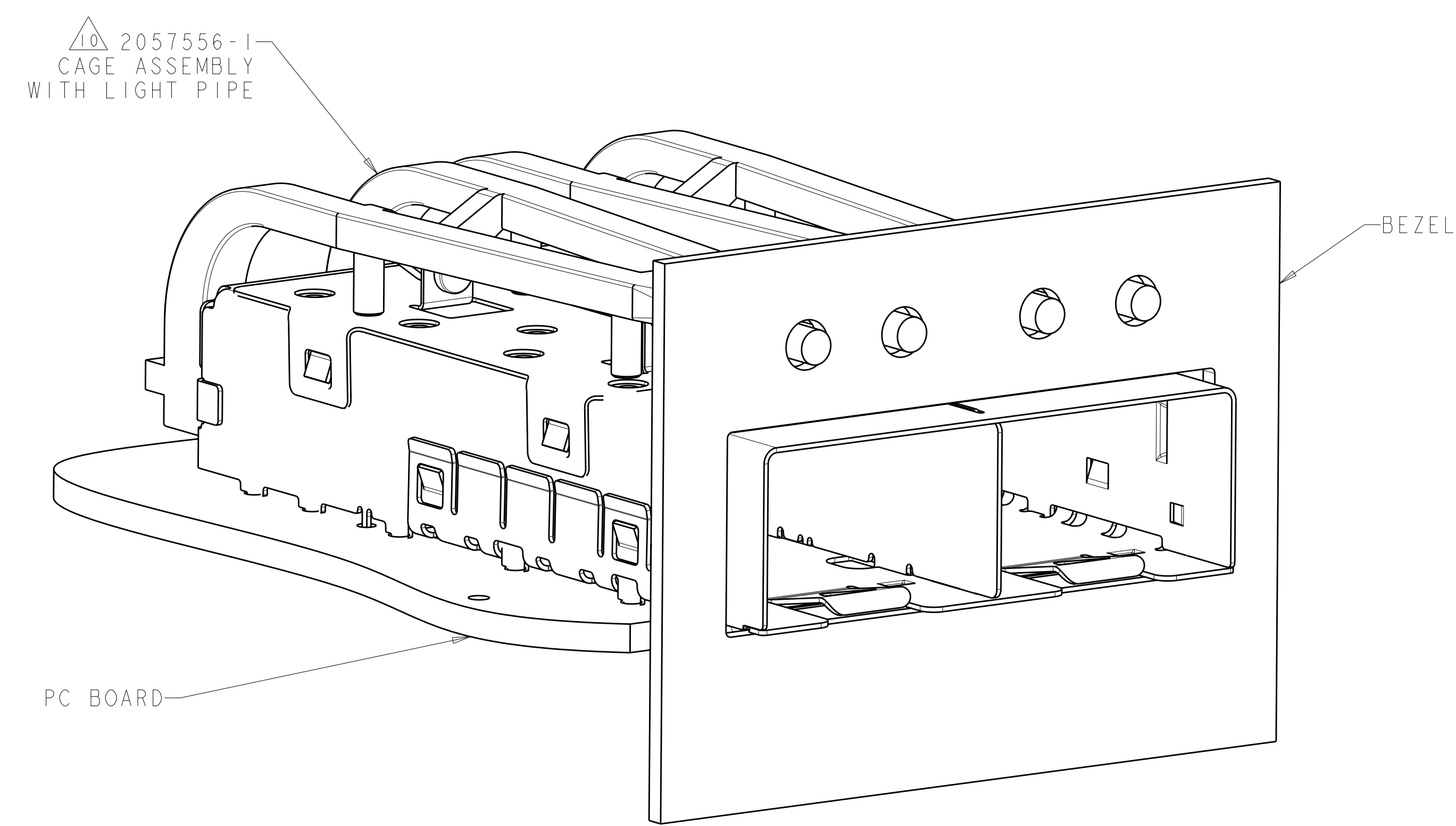

2057556-1
 MOUNTED ON PCB
 SHOWN THRU RECOMMENDED BEZEL.

<small>THIS DRAWING IS UNPUBLISHED. RELEASED FOR PUBLICATION BY TYCO ELECTRONICS CORPORATION. IT IS SUBJECT TO CHANGE WITHOUT NOTICE AND WITHOUT OBLIGATION. SHOULD BE CONTACTED FOR THE LATEST REVISION.</small>		DWN: B. MCMASTER 06OCT08 CHK: M. SCHMITT 06OCT08 APVD: M. SCHMITT 06OCT08	Tyco Electronics Harrisburg, PA 17105-3608
DIMENSIONS: mm	TOLERANCES UNLESS OTHERWISE SPECIFIED: 9 PLC ±0.13 1 PLC ±0.1 2 PLC ±0.08 3 PLC ±0.05 4 PLC ±0.05 ANGLES ±0.05 FINISH #1	NAME: SFP+ 1X2 CAGE ASSEMBLY WITH LIGHT PIPES, PRESS FIT, EMI GASKET PRODUCT SPEC APPLICATION SPEC 114-13120	SIZE: CAGE CODE DRAWING NO: A100779C-2057556 RESTRICTED TO:
MATERIAL	FINISH	WEIGHT	CUSTOMER DRAWING
		SCALE: 5:1	SHEET 2 OF 3 REV A