

THIS DRAWING IS UNPUBLISHED.		RELEASED FOR PUBLICATION	
COPYRIGHT 20 BY -		ALL RIGHTS RESERVED.	
PERFORMANCE DATA			
PHYSICAL DATA			
Contact Arrangement: Main Contacts	SPST-NO-DM (1 Form X)		
Dimensions	See Drawing		
Weight (Nominal)	0.9 lbs (410 g)		
Coil Information / Operate Voltage:			
Coil Resistance @ 20°C	3.14 ohms ± 5%		
Operate Voltage @ 20°C	6.5 Vdc (Max)		
Release Voltage @ 20°C	0.5 Vdc to 1.5 Vdc (Range)		
Minimum Hold Current at Temperature (Must operate @ 12V for 100ms before reducing to minimum holding current)	650mA		
Operate and Release Time			
Operate Time Max	40ms		
Operate Bounce Max	5ms		
Release Time Max	10ms		
Operate and Release Time			
Shock 11ms 1/2 sine (operating)	20G peak		
Sine Vibration, 20G peak	55 - 2,000 Hz		
Operating Temperature Range	-40°C to +85°C		

REVISIONS				
P	LTR	DESCRIPTION	DATE	APVD
B5		RE-ACTIVATED PER ECO-17-009872	06JUL2017	DD AL

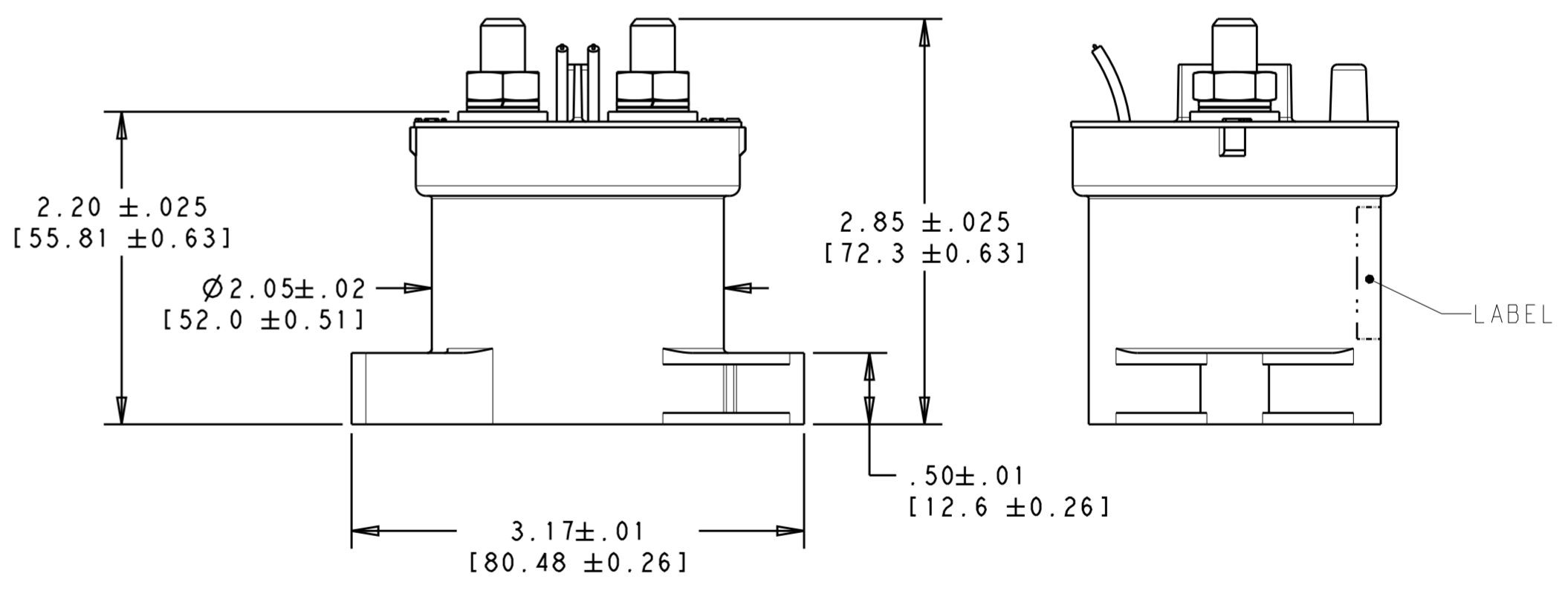
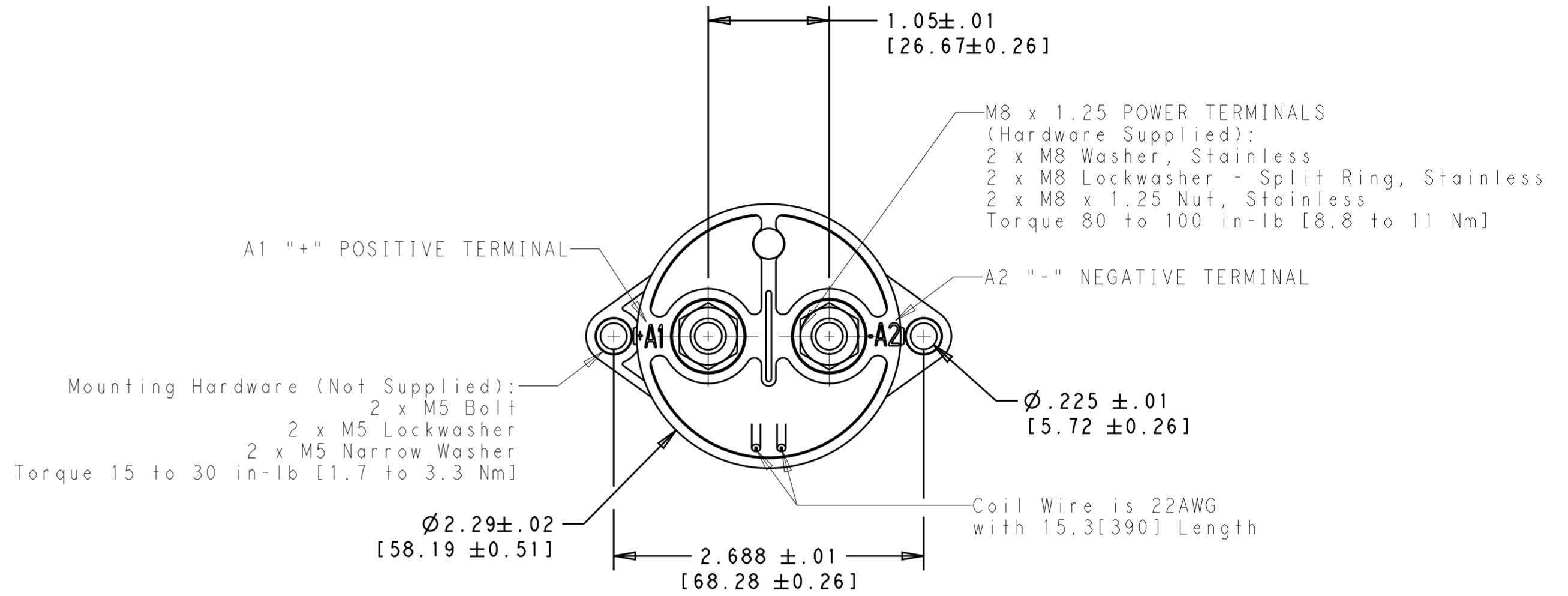

12V UN-ECONOMIZED

2098372-1
PART NUMBER

1. TO AVOID OVERHEATING, THE COIL ABOVE SHOULD NOT BE LEFT ON AT FULL POWER (12V) FOR A LONG PERIOD OF TIME.
2. THE MINIMUM HOLD CURRENT OF 650mA (MENTIONED ABOVE) ONLY PRODUCES A T-RISE OF 20°C (MAX).
3. FOR ANY OTHER INFORMATION, PLEASE REFER TO THE EV200 GENERAL CUSTOMER DATASHEET.

THIS DRAWING IS A CONTROLLED DOCUMENT.		DWN A LEE 25MAY2010	TE Connectivity															
DIMENSIONS: INCHES [mm]		CHK A LEE 25MAY2010																
TOLERANCES UNLESS OTHERWISE SPECIFIED:		APVD A LEE 25MAY2010	NAME RELAY, EVC500 SPST-NO															
<table border="1"> <tr><td>0 PLC</td><td>±</td></tr> <tr><td>1 PLC</td><td>±.1</td></tr> <tr><td>2 PLC</td><td>±.01</td></tr> <tr><td>3 PLC</td><td>±.</td></tr> <tr><td>4 PLC</td><td>±.</td></tr> <tr><td>ANGLES</td><td>±1°</td></tr> <tr><td>FINISH</td><td>-</td></tr> </table>		0 PLC	±	1 PLC	±.1	2 PLC	±.01	3 PLC	±.	4 PLC	±.	ANGLES	±1°	FINISH	-	PRODUCT SPEC -	SIZE A200779	
0 PLC	±																	
1 PLC	±.1																	
2 PLC	±.01																	
3 PLC	±.																	
4 PLC	±.																	
ANGLES	±1°																	
FINISH	-																	
MATERIAL material_2		APPLICATION SPEC -	DRAWING NO C-2098372-1															
FINISH finish_spec_2		WEIGHT -	RESTRICTED TO -															
CUSTOMER DRAWING		SCALE 1:1	SHEET 1 OF 1															
				REV B5														