

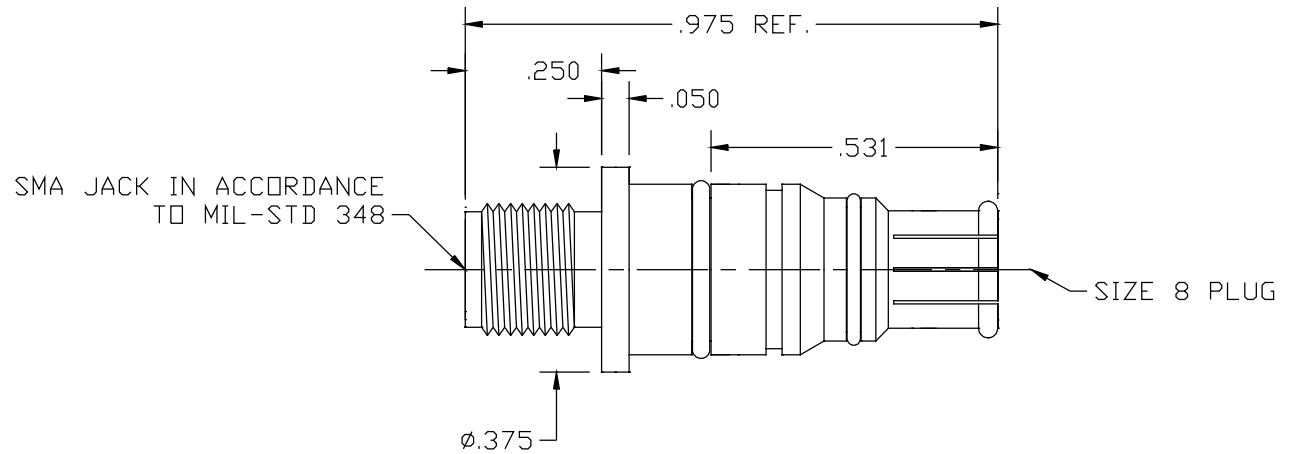

NOTES:

21-998-3016-00

Materials: Beryllium Copper per ASTM-B-196, QQ-C-530
PTFE Fluorocarbon PER ASTM-D-1710

Finish: Center Conductors, Body and solder components shall be plated per MIL-G-45204
Type II, Class 1 over Nickel plate per QQ-N-290.



LTR	DESCRIPTION	DATE	APPR.	DRAWN	CHECKED	USED ON	 SRI CONNECTOR GAGE CO. 3950 OW ROAD MELBOURNE FL. 32934			
-	REL			APPR.	SCALE	21-998-3016-00	TITLE SMA JACK TO SIZE 8 PLUG			
				UNLESS OTHERWISE SPECIFIED: 1. REMOVE ALL BURRS 2. BREAK ALL CORNERS & EDGES .005 R. MAX 3. CHAMFER 1st & LAST THREADS 45° 4. SURFACE FINISHED 32/ UNLESS OTHERWISE SPECIFIED. 5. DIAMETERS ON COMMON CENTERS TO BE CONCENTRIC WITHIN .002 T.I.R. 6. ALL DIMENSIONS ARE AFTER PLATING.					MATERIAL	
				DIMENSIONS ARE IN INCHES TOLERANCES			FINISH			
				DECIMALS	FRACTIONAL	ANGULAR	SIZE	FSCM NO.	SHEET	DWG. NO.
				.X ±.030		.X° ±1°0'	A	OHMO1	1	21-998-3016-00
				.XX ±.010	± 1/64	.X°X' ±15'				
				.XXX +.005						