

THIS DRAWING IS UNPUBLISHED. RELEASED FOR PUBLICATION
 © COPYRIGHT BY TYCO ELECTRONICS CORPORATION. ALL INTERNATIONAL RIGHTS RESERVED.

HOUSING CLAMP NUT MOUNTING NUT	BRASS PER ASTM-B-16, HALF HARD	NICKEL PLATE PER AMS-QQ-N-290
DIELECTRIC	TFE FLUOROCARBON PER ASTM-D-1457	N/A
SLEEVE, CENTER CONTACT	BRASS PER ASTM-B-16, HALF HARD	GOLD PLATE PER ASTM-B-488
LOCKWASHER	PHOSPHOR BRONZE PER AMS-QQ-B-750, GRADE B2	NICKEL PLATE PER AMS-QQ-N-290
GASKET	SILICONE RUBBER PER ZZ-R-765	N/A
SHRINK TUBING	HEAT SHRINKABLE POLYOLEFIN COMPOUND MIL-I-23053/4	N/A
FERRULE	COPPER OR BRASS ALLOY ROCKWELL F65 MAXIMUM	GOLD PLATE PER ASTM-B-488
COMPONENT	MATERIAL	FINISH

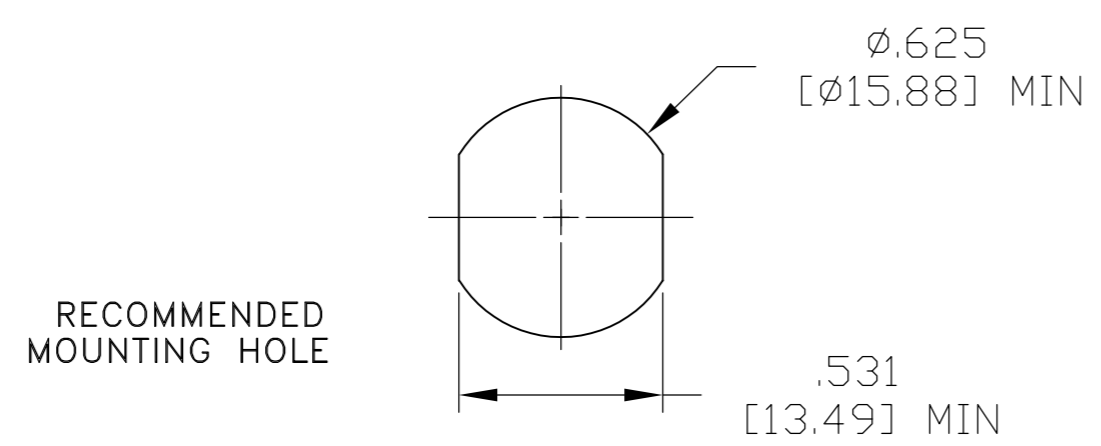

DESIGNED FOR USE WITH
RG-188/U FLEX CABLE

CABLE ENTRY DIAMETER
MINIMUM

FERRULE	.128 [3.25]
SLEEVE	.066 [1.68]
CONTACT	.023 [0.58]

LOC	DIST	REVISIONS			
P	LTR	DESCRIPTION	DATE	DWN	APVD
B		RELEASED PER ECO 09-020246	15SEP09	PY	BM

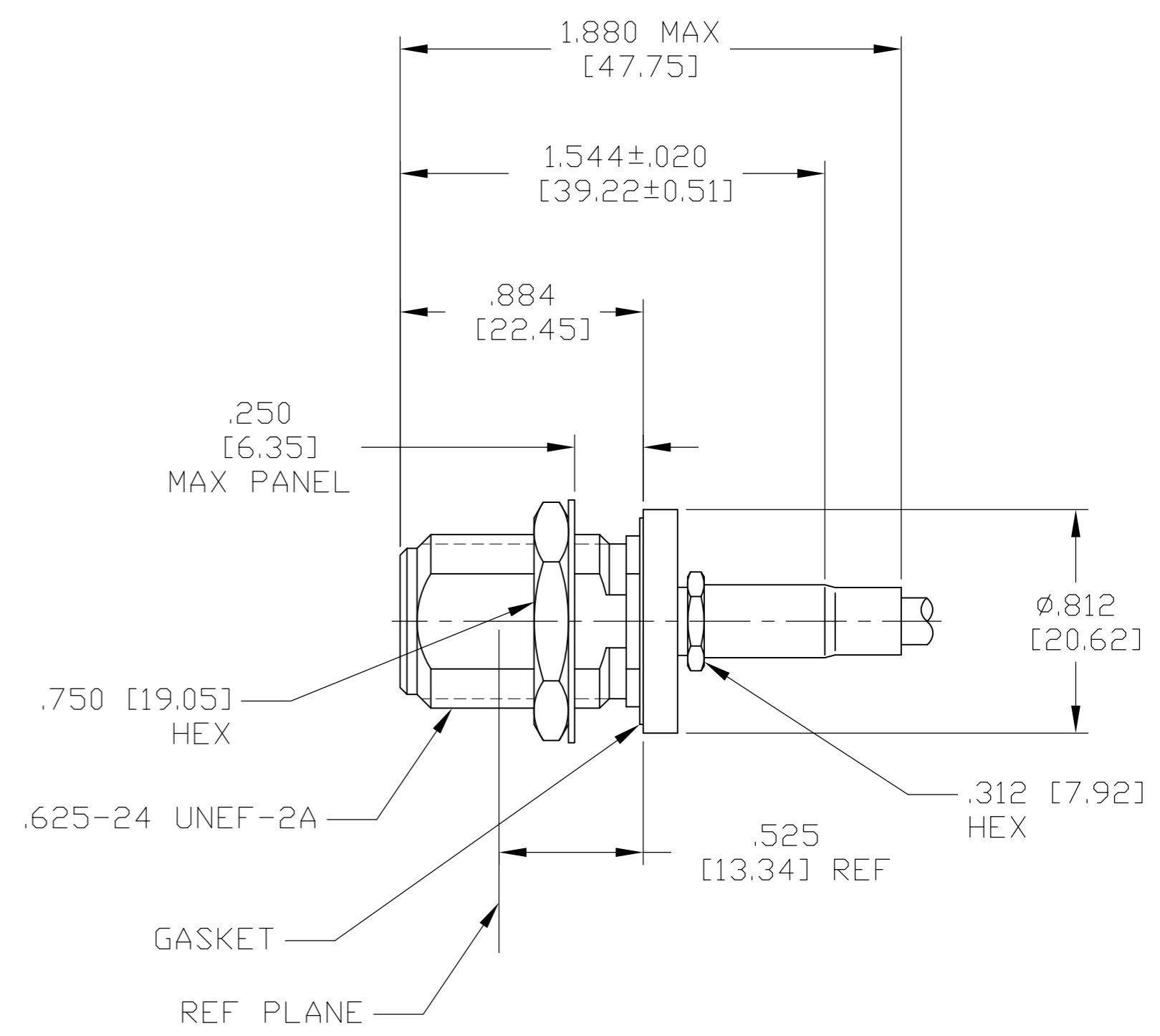

ELECTRICAL	MECHANICAL	ENVIRONMENTAL
Nominal Impedance (Ohms) <u>50</u>	Interface Dimensions MIL-STD-348A, Fig. 304.2	TEMPERATURE RATING <u>-65°C TO +125°C</u>
Frequency Range (GHz) DC to <u>11</u>	Recommended Mating Torque <u>N/A</u>	Vibration MIL-STD-202, Method 204, Condition B
Volt Rating (VRMS MAX) @ Sea Level <u>250</u>	Mating Characteristics: Insertion (MAX Lbs) <u>2.0</u>	Shock MIL-STD-202, Method 213, Condition I
VSWR <u>1.20+.025f(GHz)</u>	Withdrawal (MIN Oz) <u>2.0</u>	Thermal Shock MIL-STD-202, Method 107, Condition B, EXCEPT HIGH TEMP 115°C
Insertion Loss (dB MAX) <u>.10 √f(GHz)</u>	Force to Engage and Disengage (In-Lbs MAX) <u>6.0</u>	Moisture Resistance MIL-STD-202, Method 106
RF Leakage (dB MIN) <u>-[60-f(GHz)]</u>	Center Contact Captivation Axial (Lbs) <u>6.0</u>	Corrosion - MIL-STD-202, Method 101, Condition B, 5% salt spray
Corona, 70,000 Ft (VRMS MIN) <u>190</u>	Cable Retention Axial Force (Lbs) <u>20 MIN</u>	
Dielectric Withstanding Voltage (VRMS MIN) @ Sea Level <u>750</u>	Torque (In-Oz) <u>N/A</u>	
Contact Resistance (Milliohms MAX) Center Contact <u>1.5</u>	Weight (Grams) <u>TBD</u>	
Outer Contact <u>2.0</u>		
Cable to Housing <u>0.5</u>		
RF High Potential @ Sea Level (VRMS MIN @ 5 MHz) <u>500</u>		
I.R.(Megohms MIN) <u>5000</u>		

THIS DRAWING IS A CONTROLLED DOCUMENT.

DWN	C.C.THOMAS	7-21-09	Tyco Electronics Corporation Harrisburg, PA 17105-3608
CHK	B.MOYER	7-22-09	
APVD	B.MOYER	7-22-09	
PRODUCT SPEC	408-04882		
APPLICATION SPEC			NAME
MATERIAL SEE CALLOUTS			FINISH SEE CALLOUTS
WEIGHT -			SIZE A2
CUSTOMER DRAWING			CAGE CODE 00779
SCALE 2:1			DRAWING NO C-2101297
SHEET 1 of 1			RESTRICTED TO -
REV B			