

THIS DRAWING IS UNPUBLISHED. RELEASED FOR PUBLICATION
 © COPYRIGHT BY TYCO ELECTRONICS CORPORATION. ALL INTERNATIONAL RIGHTS RESERVED.

LOC		DIST		REVISIONS			
P	LTR	DESCRIPTION	DATE	DWN	APVD		
	A	RELEASED PER ECO 10-010178	5-15-10	CT	DW		

COMPONENT	MATERIAL	FINISH
HOUSING COUPLING NUT CLAMP NUT SLEEVE	STAINLESS STEEL PER ASTM-A484 AND ASTM- A582, TYPE 303	GOLD PLATE PER ASTM-B-488
DIELECTRIC	PTFE FLUOROCARBON PER ASTM-D-1457	N/A
REAR DIELECTRIC	NYLON OR ZYTEL #101 PER MIL-M-20693A	N/A
CENTER CONTACT	BERYLLIUM COPPER PER ASTM-B-196 OR ASTM-B-197, ALLOY C17300, CONDITION H	GOLD PLATE PER ASTM-B-488
RETAINING RING	BERYLLIUM COPPER PER ASTM B 194, ALLOY C17200, CONDITION H	N/A
GASKET O-RING	SILICONE RUBBER PER ZZ-R-765	N/A
SHRINK TUBING	HEAT SHRINKABLE POLYOLEFIN COMPOUND MIL-I-23053/4	N/A
FERRULE	COPPER OR BRASS ALLOY ROCKWELL F65 MAXIMUM	GOLD PLATE PER ASTM-B-488

1. PARTS SHIPPED UNASSEMBLED.

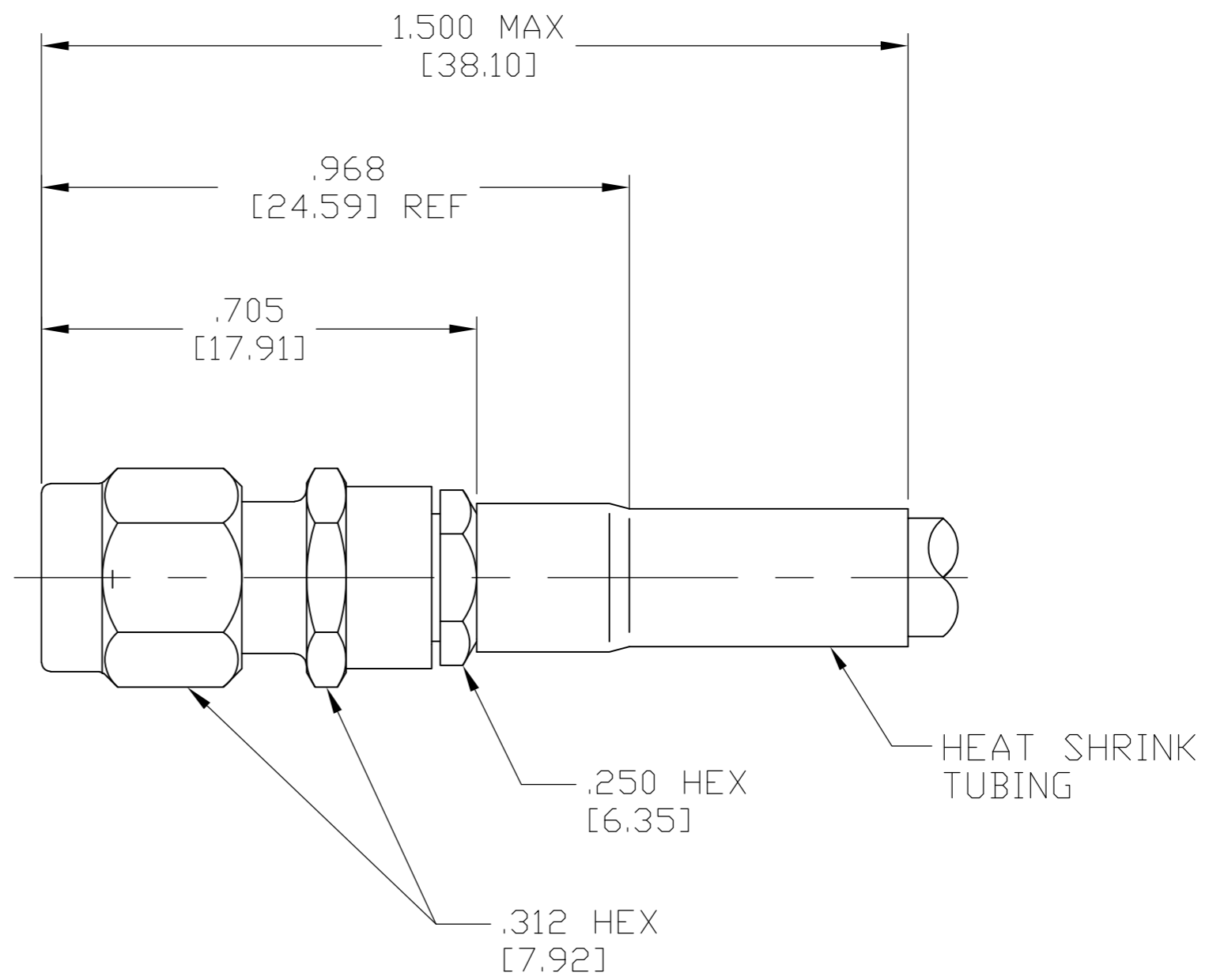

ELECTRICAL	MECHANICAL	ENVIRONMENTAL
Nominal Impedance (Ohms) 50	Interface Dimensions MIL-STD-348A, Fig. 310.1	TEMPERATURE RATING -65°C TO +165°C
Frequency Range (GHz) DC to 4.0	Recommended Mating Torque 7-10 IN-LB	Vibration MIL-STD-202, Method 204, Condition D
Volt Rating (VRMS MAX) @ Sea Level 335	Mating Characteristics:	Shock MIL-STD-202, Method 213, Condition I
VSWR 1.15+.02 f(GHz)	Insertion (MAX Lbs) N/A	Thermal Shock MIL-STD-202, Method 107, Condition C,
Insertion Loss (dB MAX) .06√f(GHz)	Withdrawal (MIN Oz) N/A	Moisture Resistance MIL-STD-202, Method 106,
RF Leakage (dB MIN) -[60-f(GHz)]	Force to Engage and Disengage (In-Lbs MAX) 2	Corrosion - MIL-STD-202, Method 101, Condition B, 5% salt spray
Corona, 70,000 Ft (VRMS MIN) 190	Center Contact Captivation	
Dielectric Withstanding Voltage (VRMS MIN) @ Sea Level 750	Axial (Lbs) 6.0	
Contact Resistance (Milliohms MAX)	Radial (In-Oz) N/A	
Center Contact 3.0	Cable Retention	
Outer Contact 2.0	Axial Force (Lbs) 20 MIN	
Cable to Housing 0.5	Torque (In-Oz) N/A	
RF High Potential @ Sea Level (VRMS MIN @ 5 MHz) 500	Weight (Grams) TBD	
I.R.(Megohms MIN) 5,000		

DESIGNED FOR USE WITH RG-195/U OR EQUIVALENT CABLE ENTRY DIAMETER MINIMUM	
CONTACT	.021 [0.53]
SLEEVE	.105 [2.67]
CLAMP NUT	.179 [4.55]

THIS DRAWING IS A CONTROLLED DOCUMENT.		DWN C.C.THOMAS 5-15-10	Tyco Electronics Corporation Harrisburg, PA 17105-3608	
DIMENSIONS: INCHES [mm]		CHK D.WILSON 5-18-10	NAME SMA STRAIGHT CABLE PLUG KIT, CRIMP ATTACHMENT	
TOLERANCES UNLESS OTHERWISE SPECIFIED:		APVD D.WILSON 5-18-10	PRODUCT SPEC 408-04812	
0 PLC ± -		APPLICATION SPEC		
1 PLC ± -		SIZE A2		
2 PLC ± -		CAGE CODE 00779		
3 PLC ± .005 [0.13]		DRAWING NO C=2101903		
4 PLC ± -		RESTRICTED TO		
ANGLES ± -		SCALE 4:1		
MATERIAL SEE TABLE		SHEET 1 of 1		
FINISH SEE TABLE		REV A		
CUSTOMER DRAWING				

2101903-1
PART NUMBER