

LOC	DIST	REVISIONS					
		P	LTN	DESCRIPTION	DATE	DMN	APVD
CM	00	A2		REVISED PER ECO-12-003780	25FEB2012	HVG	DD
		B		REVISED PER ECR-13-008007	17SEP2013	RS	DD
		B1		REVISED PER ECR-19-010402	04JUL2019	SR	DD
		B2		REVISED PER ECR-19-019415	16DEC2019	SB	DD

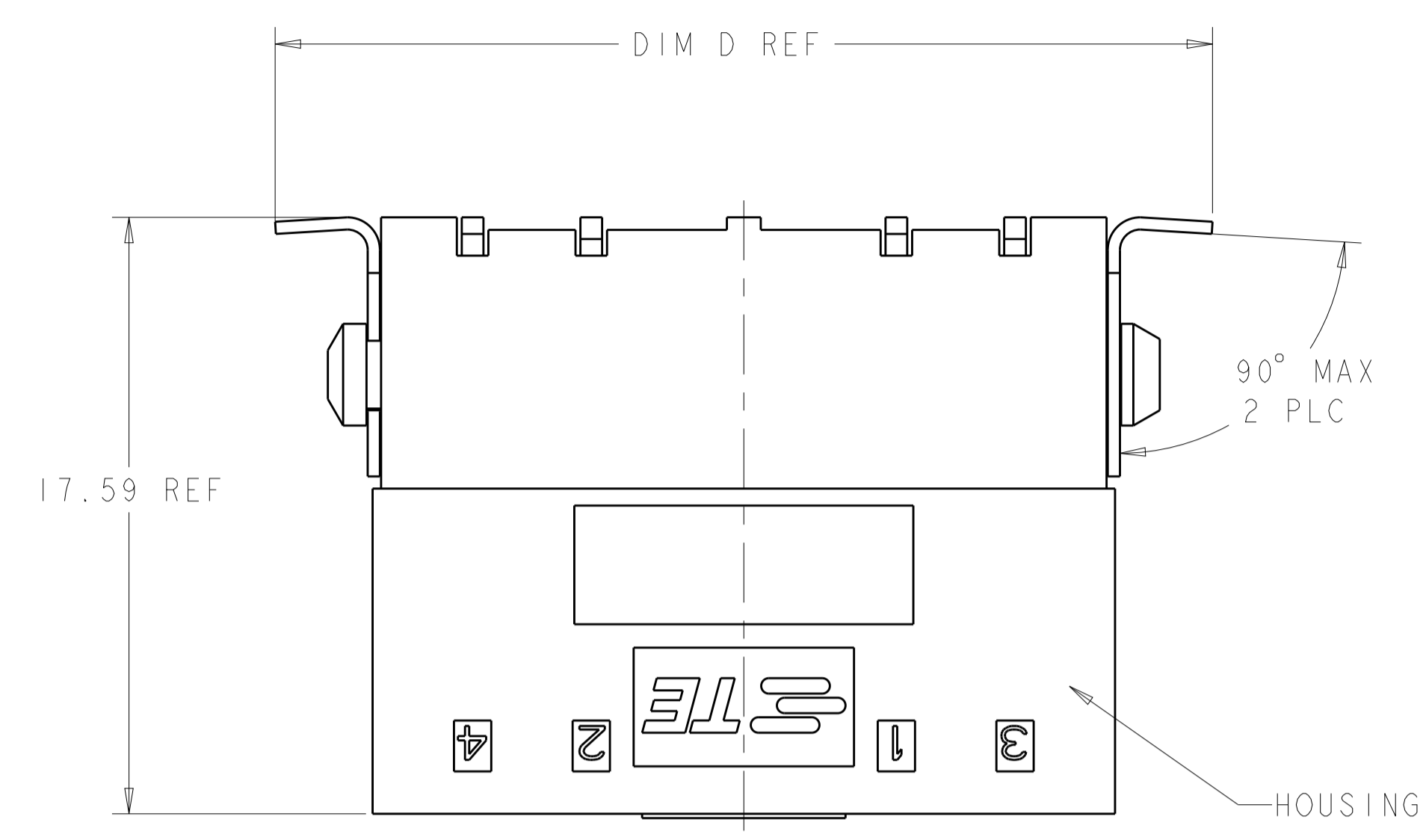

- 1 MATERIAL: HOUSING: LCP, COLOR: BLACK.
- 2 CONTACTS: BRASS.
FINISH: 2.54µm MIN MATTE TIN OVER NICKEL (ENTIRE POST).
HOLDDOWN: COPPER ALLOY.
FINISH: 2.54µm MIN MATTE TIN OVER NICKEL.
- 3 VACUUM PICK-UP
BUTTON: POLYIMIDE.
- 4 THIS PRODUCT HAS NOT COMPLETED VALIDATION TESTING.
- 5 RECOMMENDED PC BOARD THICKNESS OF 1.57.
- 6 TAPE AND REEL PACKAGING PER EIA-481 SPEC.
- 7 MUST COMPLY WITH DIRECTIVE 2002/95/EC (ROHS).

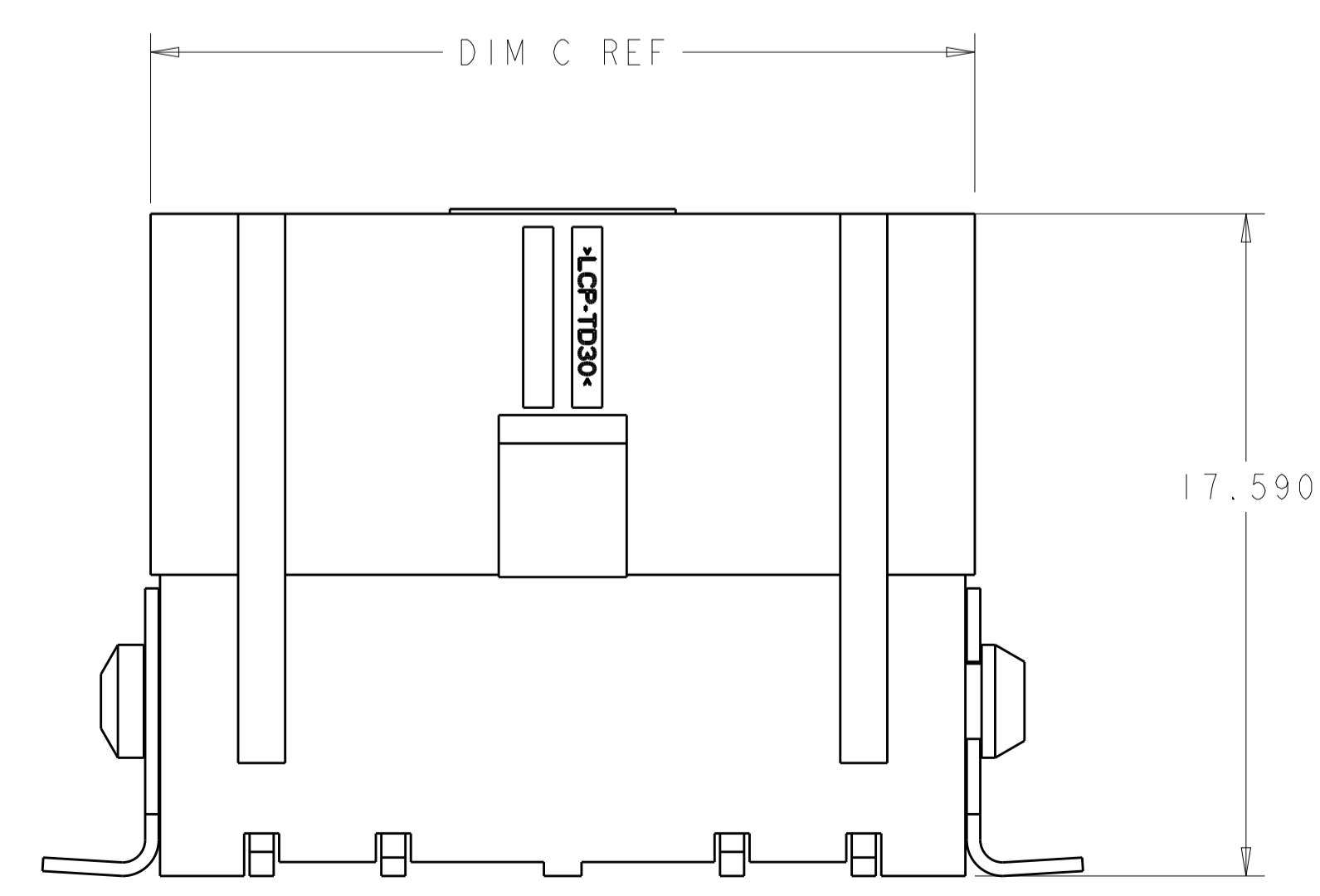
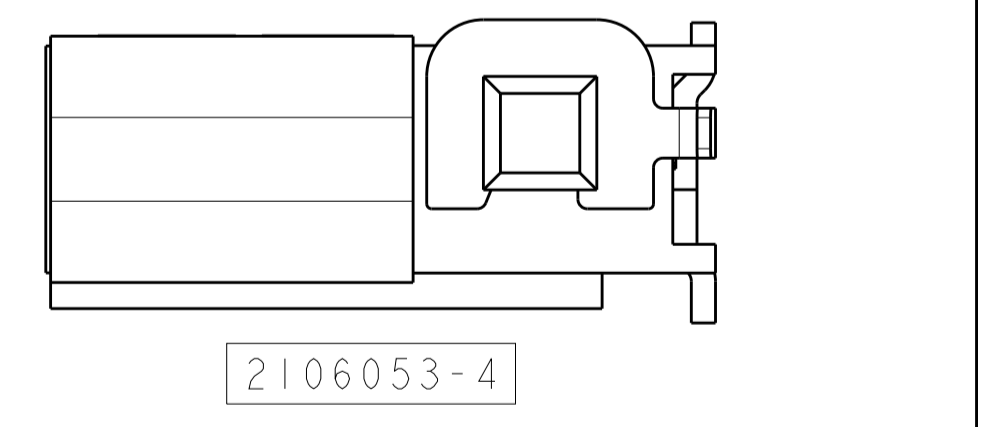
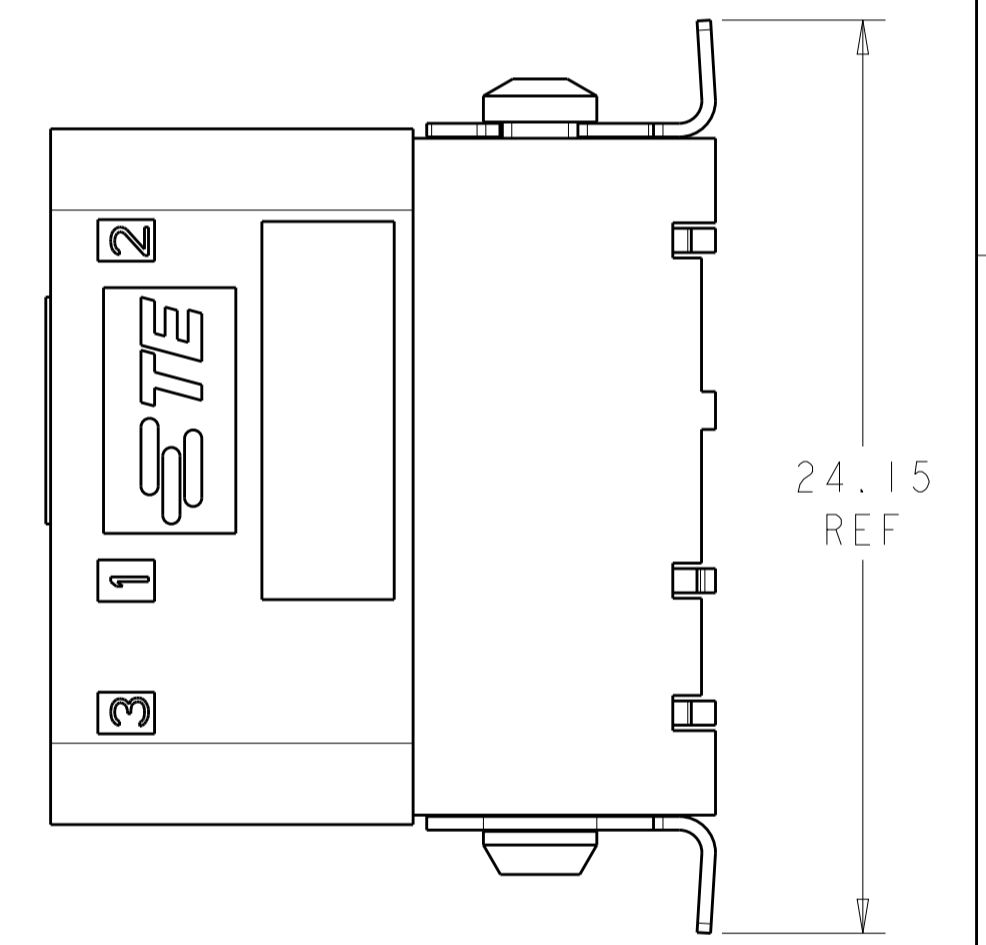
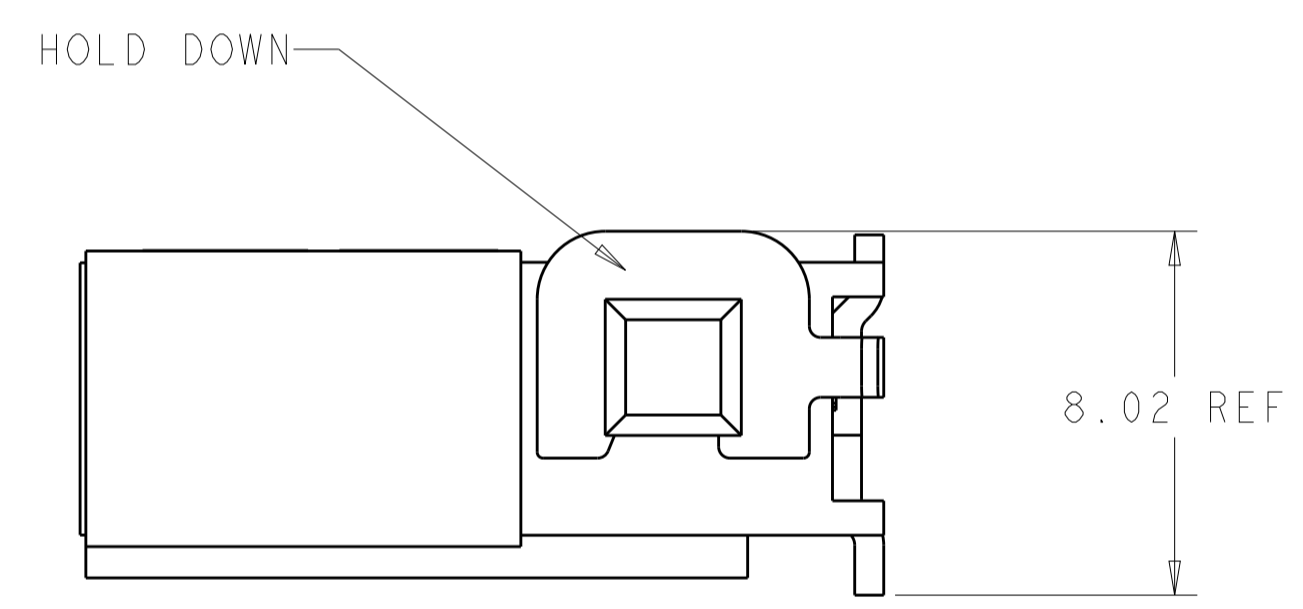
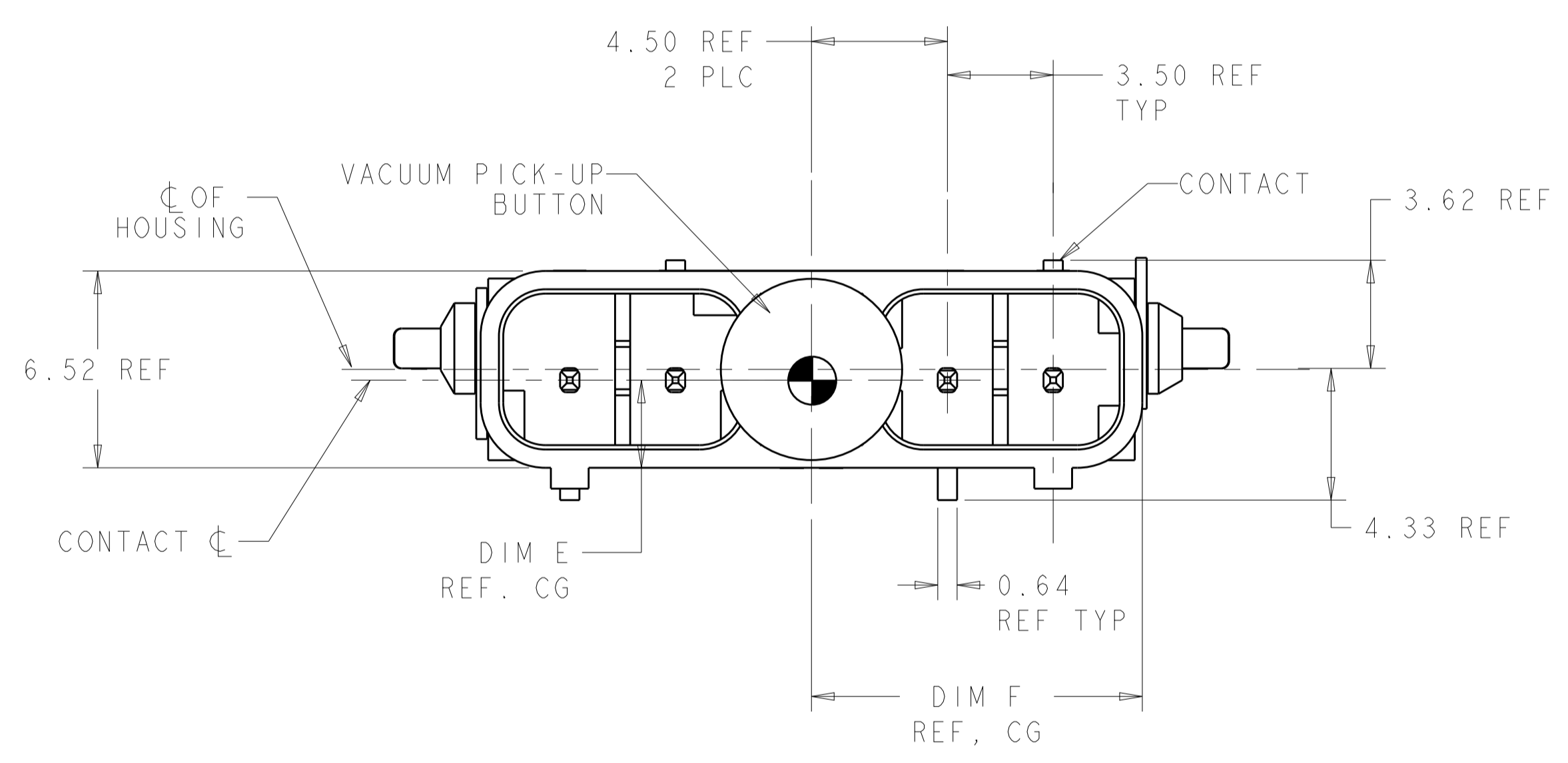
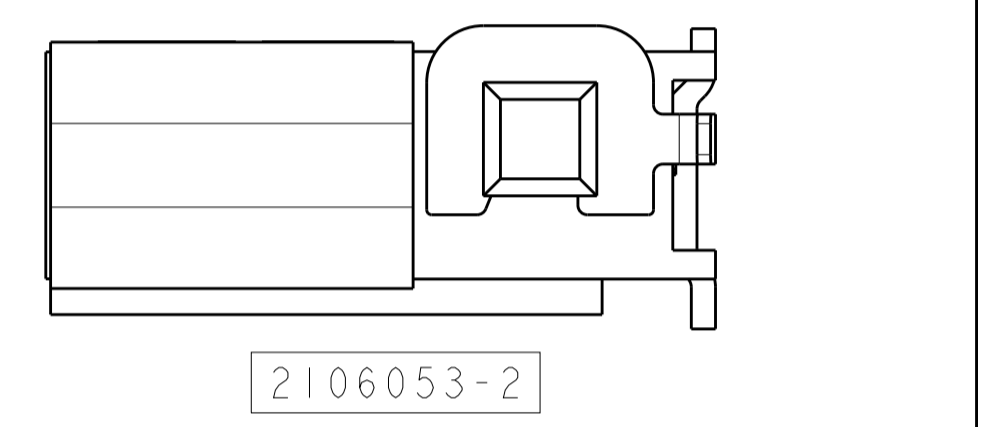
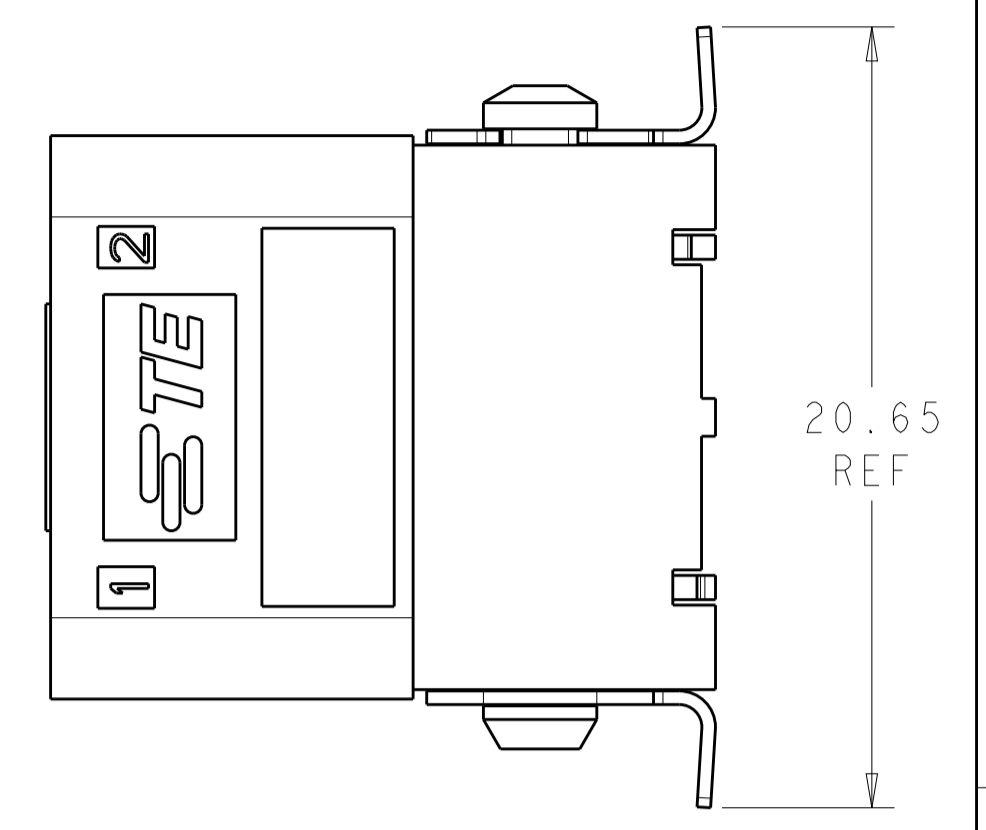

10.94	3.19	27.65	21.90	12.46	12.46	4	2106053-6
9.20	3.20	24.15	18.40	8.96	12.46	3	2106053-4
7.44	3.18	20.65	14.90	8.96	8.96	2	2106053-2
DIM F	DIM E	DIM D	DIM C	DIM B	DIM A	POSN	PART NUMBER

THIS DRAWING IS A CONTROLLED DOCUMENT. DMN: HM VAN SCOY 23JAN2009
 CHK: A. BUCHER 23JAN2009
 APVD: A. BUCHER 23JAN2009

STE TE Connectivity

ASSEMBLY, VERTICAL SMT HEADER, SLIMSEAL SSL CONNECTOR

PRODUCT SPEC: 108-2391
 APPLICATION SPEC: 114-13261
 WEIGHT: -
 CUSTOMER DRAWING

DIMENSIONS: mm
 TOLERANCES UNLESS OTHERWISE SPECIFIED:
 0 PLC ±0.2
 1 PLC ±0.15
 2 PLC ±0.15
 3 PLC ±0.15
 4 PLC ±0.15
 ANGLES ±0.5°

MATERIAL: 1 2 3
 FINISH: 2

SIZE: A1
 CAGE CODE: 100779
 DRAWING NO: 2106053
 SCALE: 4:1
 SHEET: 1 OF 2
 REV: B2

LOC	DIST	REVISIONS			
P	LTN	DESCRIPTION	DATE	DMN	APVD
-	-	SEE SHEET 1	-	-	-

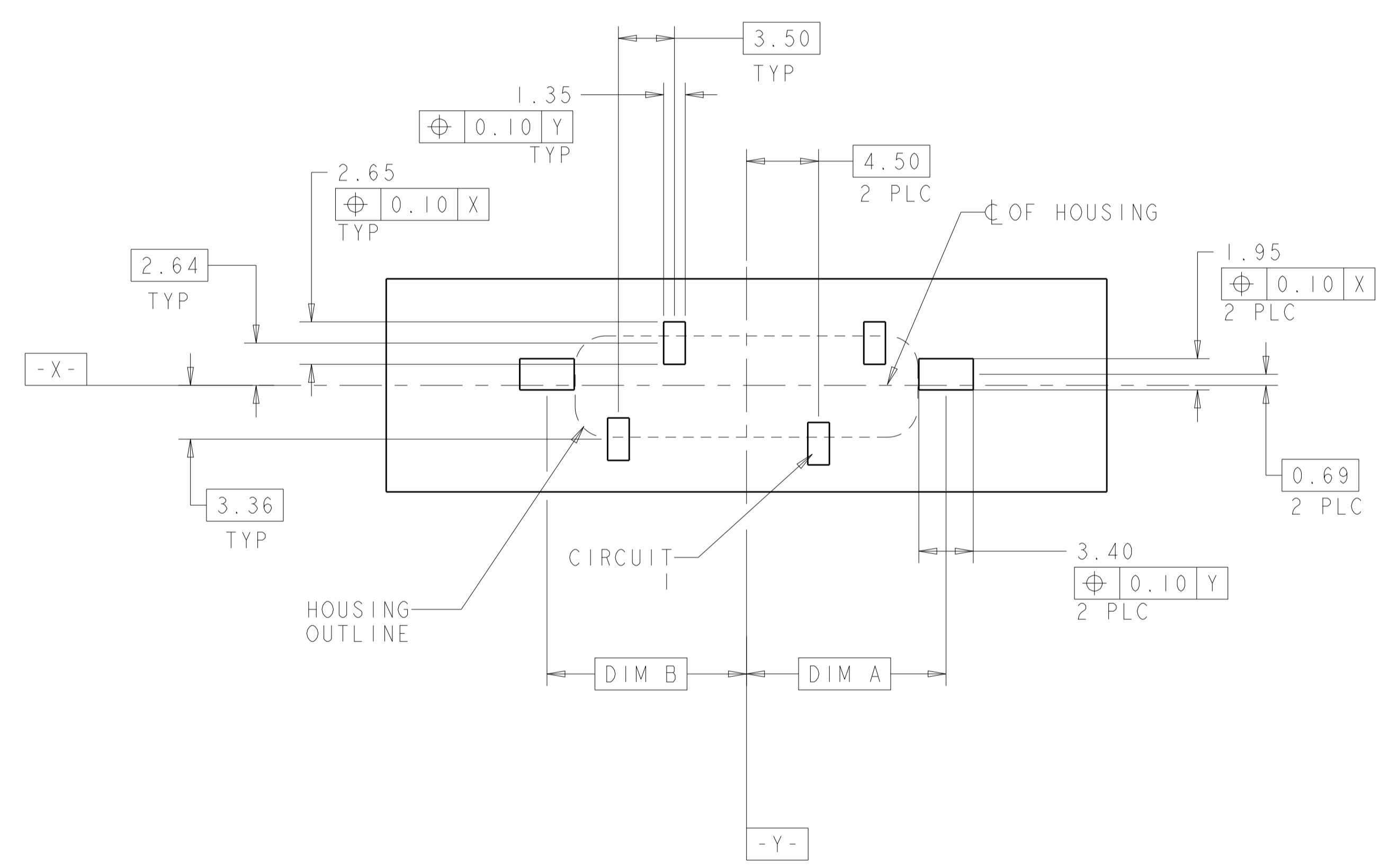

RECOMMENDED PC BOARD PAD LAYOUT, COMPONENT SIDE
 DIMENSIONS APPLY TO ALL POSITIONS UNLESS OTHERWISE NOTED

RECOMMENDED SOLDER PASTE VOLUME 1.59 CUBIC MILLIMETERS FOR THE CONTACT AND 1.08 CUBIC MILLIMETERS FOR THE SMT HOLD DOWN WHEN USING 80% METALLIC SOLIDS SOLDER PASTE. THE SOLDER STENCIL THICKNESS SHOULD BE 0.16 mm OR GREATER.

THIS DRAWING IS A CONTROLLED DOCUMENT.		DMN: MM VAN SCIO 23JAN2009	TE Connectivity
DIMENSIONS: mm		CHK: A. BUCHER 23JAN2009	
TOLERANCES UNLESS OTHERWISE SPECIFIED:		APVD: A. BUCHER 23JAN2009	NAME: ASSEMBLY, VERTICAL SMT HEADER, SLIMSEAL SSL CONNECTOR
0 PLC ±0.2	1 PLC ±0.15	PRODUCT SPEC: 108-2391	RESTRICTED TO:
2 PLC ±0.15	3 PLC ±0.15	APPLICATION SPEC: 114-13261	SIZE: A1
4 PLC ±0.15	ANGLES ±0°	WEIGHT: -	CAGE CODE: 2106053
MATERIAL:		FINISH:	CUSTOMER DRAWING
SCALE: 4:1		SHEET: 2 OF 2	REV: B2