

LOC	DIST	REVISIONS					
GP	00	P	LTN	DESCRIPTION	DATE	DWN	APVD
		B		REVISE PER ECO-09-022874	9OCT2009	ZMR	MRS
		C		REVISED PER ECO-10-004036	91MAR2010	CJV	MRS
		D		REVISED PER ECO-12-014021	10DEC2012	TD	AC

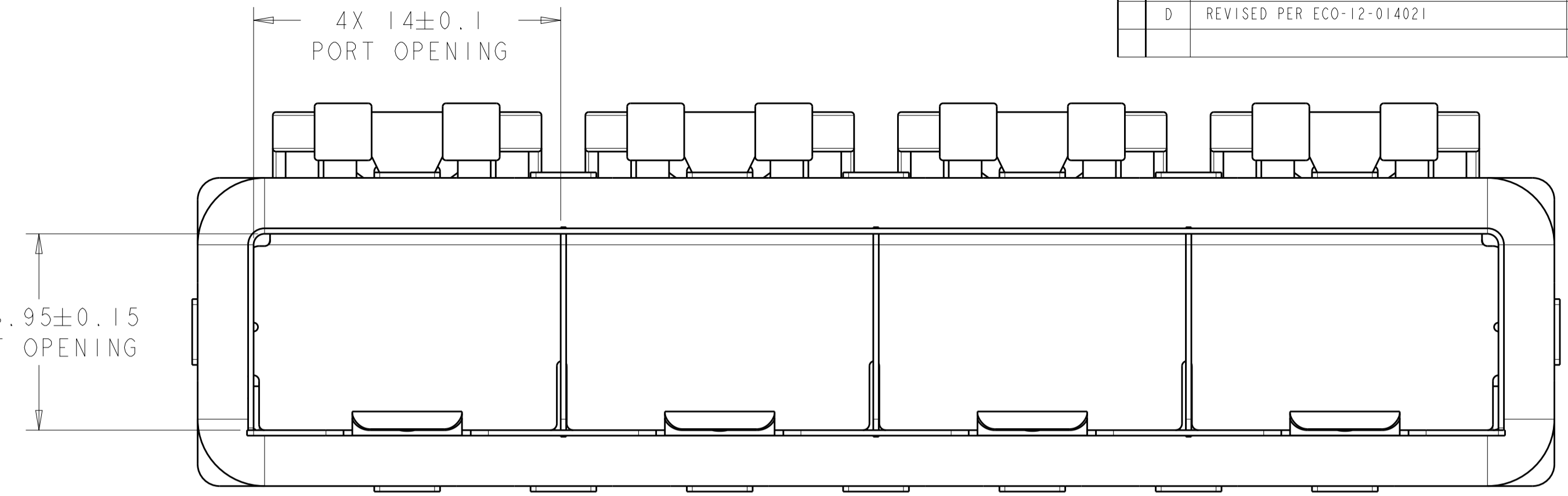

- 1 MATERIAL:  
 CAGE ASSEMBLY - 0.25mm THICK NICKEL SILVER ALLOY  
 GASKET RETENTION PLATE - STAINLESS STEEL  
 GASKET - PLATED FILLED SILICONE  
 LIGHT PIPE BRACKET - STAINLESS STEEL  
 LIGHT PIPE - POLYCARBONATE, CLEAR
- 2 MINIMUM PC BOARD THICKNESS = 1.50mm.
- 3 PADS AND VIAS CHASSIS GROUND.
- 4 DATUM AND BASIC DIMENSION ESTABLISHED BY CUSTOMER.
- 5. MATES WITH SFP MSA COMPLIANT TRANSCEIVERS.
- 6. INTERPRETATION OF DATUM REFERENCE FRAME IN ACCORDANCE WITH SECT 4.4.1.1 OF ASME Y14.5M-1994.
- 7 REFERENCE APPLICATION SPEC. 114-13120, HOLE A, FOR RECOMMENDED DRILL HOLE DIAMETER AND PLATING THICKNESS.
- 8 REFERENCE APPLICATION SPEC. 114-13120, HOLE B, FOR RECOMMENDED DRILL HOLE DIAMETER AND PLATING THICKNESS.
- 9 HOLE PATTERN REPEATS FOR EACH PORT. SPACING BETWEEN PORTS IS 14.25mm.
- 10 LIGHT PIPE ASSEMBLY SHIPPED UNASSEMBLED TO CAGE ASSEMBLY. CAGE ASSEMBLY TO BE PRESSED INTO THE PCB PRIOR TO ATTACHING THE LIGHT PIPE ASSEMBLY TO THE CAGE.
- 11. PRODUCT COMPLIES WITH SPECIFICATION SFF-8433 IMPROVED PLUGGABLE FORM FACTOR FOR SFP+ GANGED CAGES.

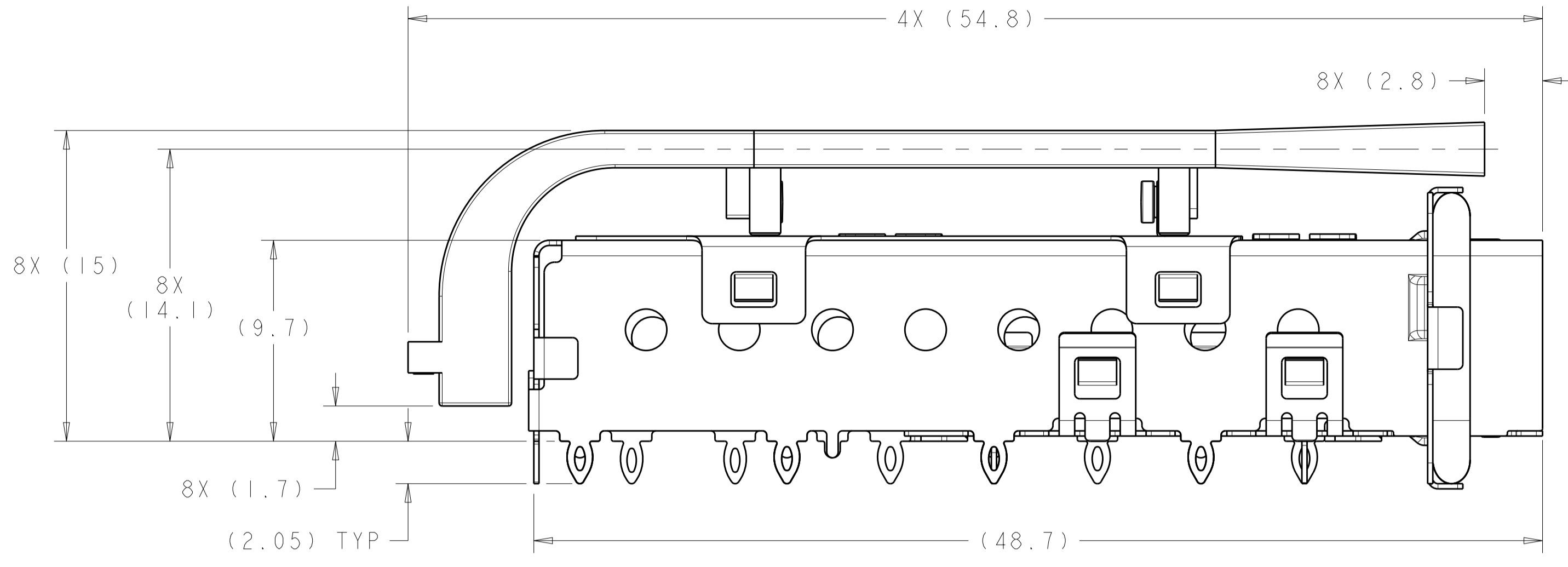
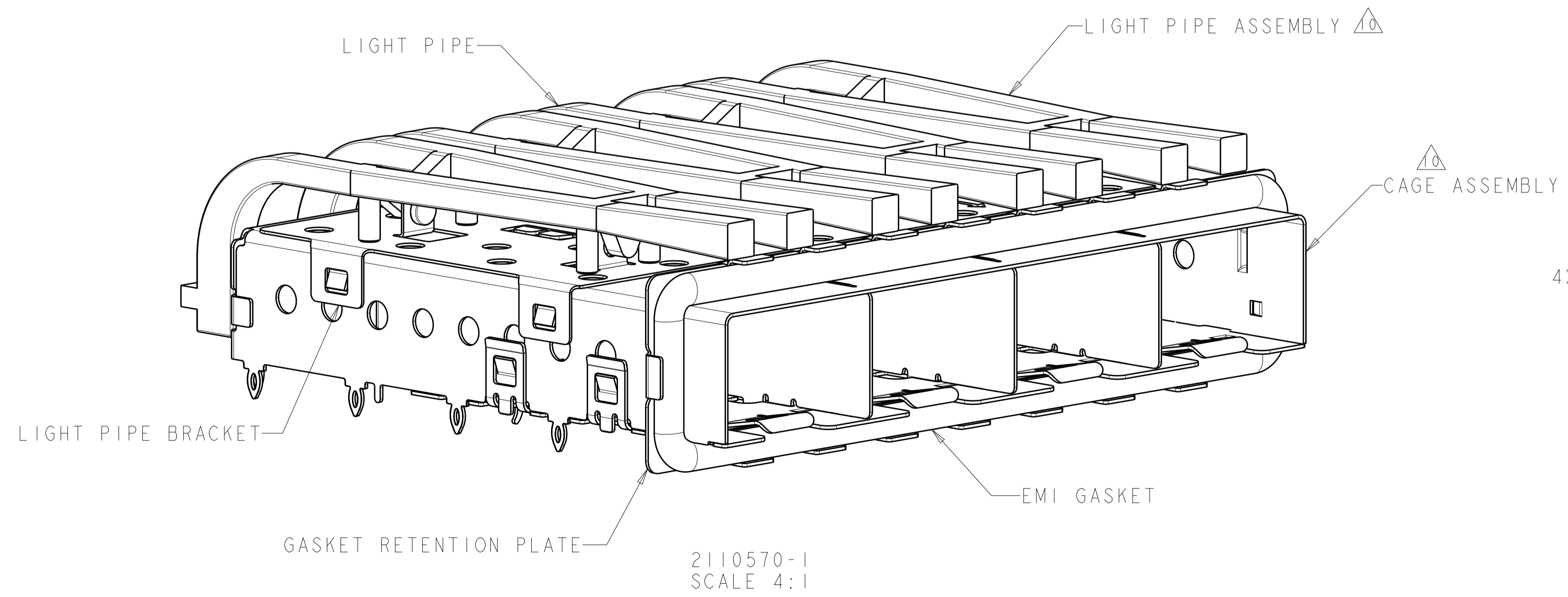
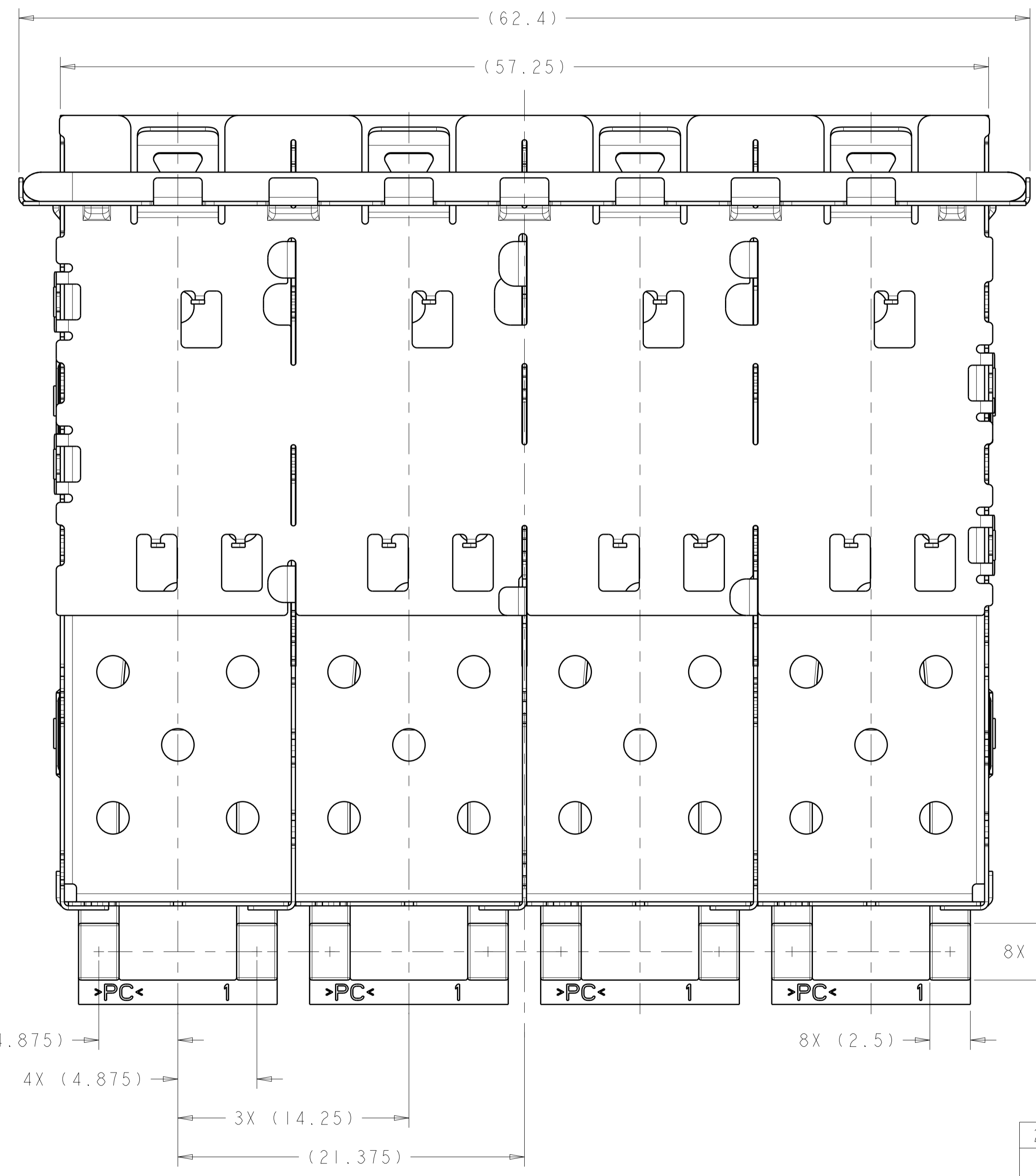

2110570-1  
 SCALE 4:1

2110570-1  
 PART NUMBER

THIS DRAWING IS A CONTROLLED DOCUMENT.		DWN Z. M. BEAM 13APR2009	TE Connectivity SFP+ 1X4 CAGE ASSEMBLY, PRESS FIT, EMI GASKET, W/ REDUCED LENGTH SQUARE LIGHT PIPES
DIMENSIONS:		CHK M. R. SCHMITT 13APR2009	
TOLERANCES UNLESS OTHERWISE SPECIFIED:		APVD B. H. WERTZ 13APR2009	
mm		PRODUCT SPEC 108-2364	
0 PLC ±0.1		APPLICATION SPEC 114-13120	SIZE A100779
1 PLC ±0.1		WEIGHT	CAGE CODE 2110570
2 PLC ±0.1		FINISH	RESTRICTED TO
3 PLC ±0.1			Customer Drawing
4 PLC ±0.1			SCALE 1:1 SHEET 1 OF 3 REV D
ANGLES ±0.1			

LOC	DIST	REV	DATE	BY	APPV
GP	00				

REVISIONS			
REV	DATE	BY	APPV
-	-	-	-
-	-	-	-

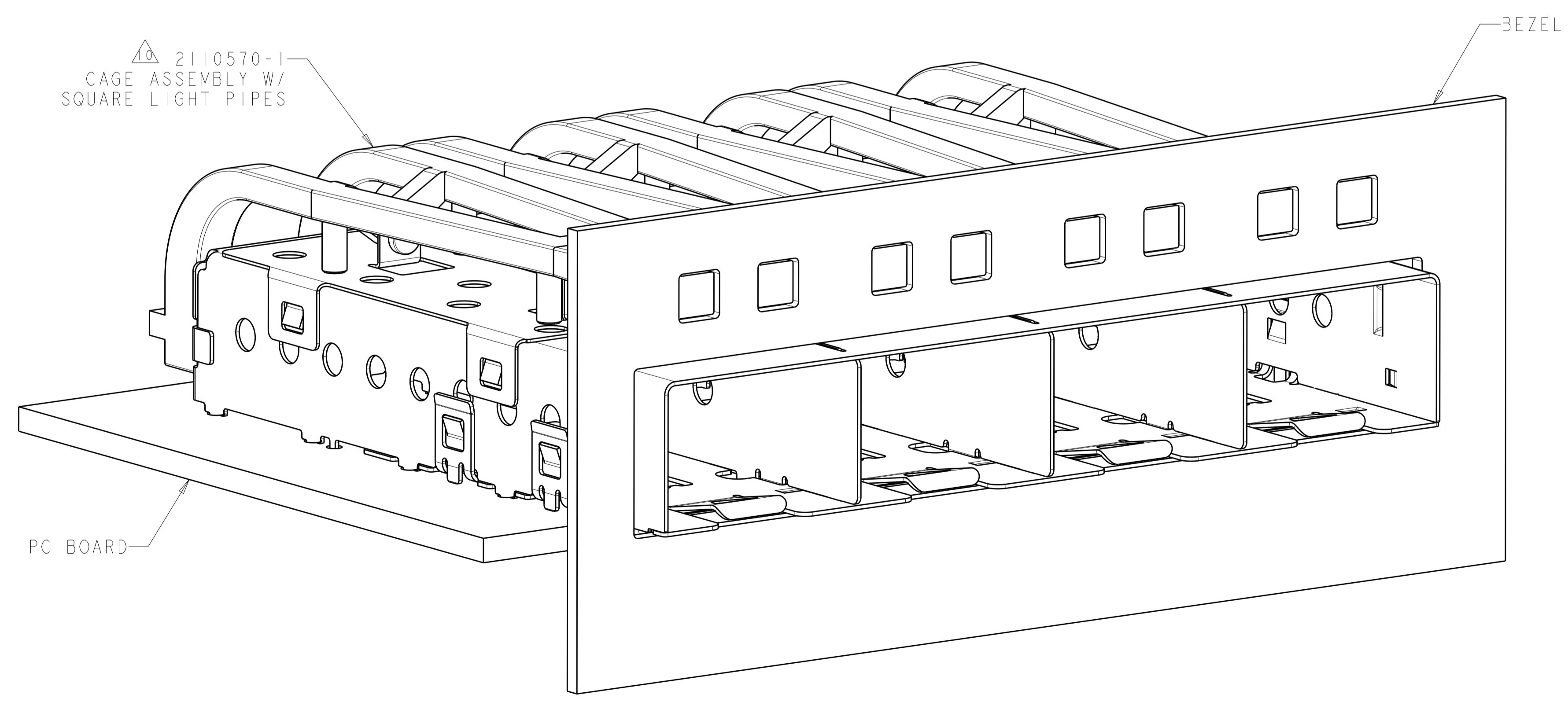
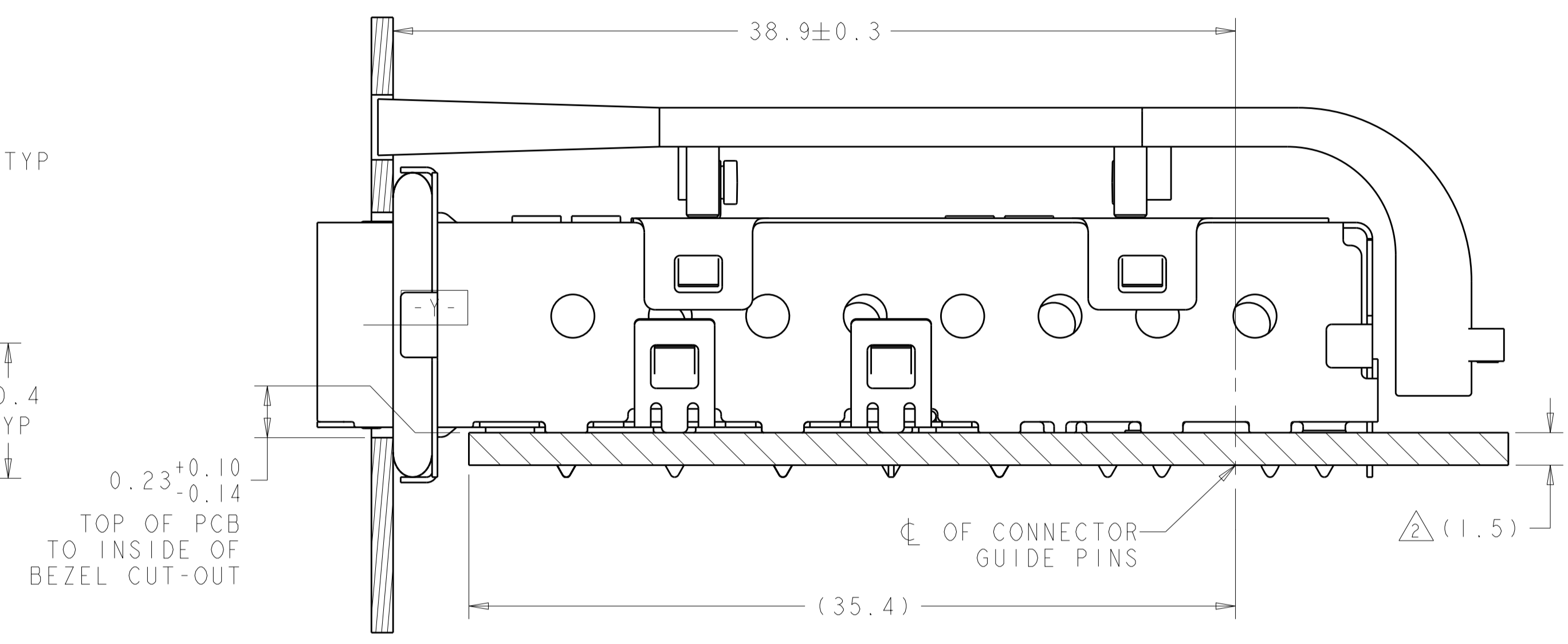
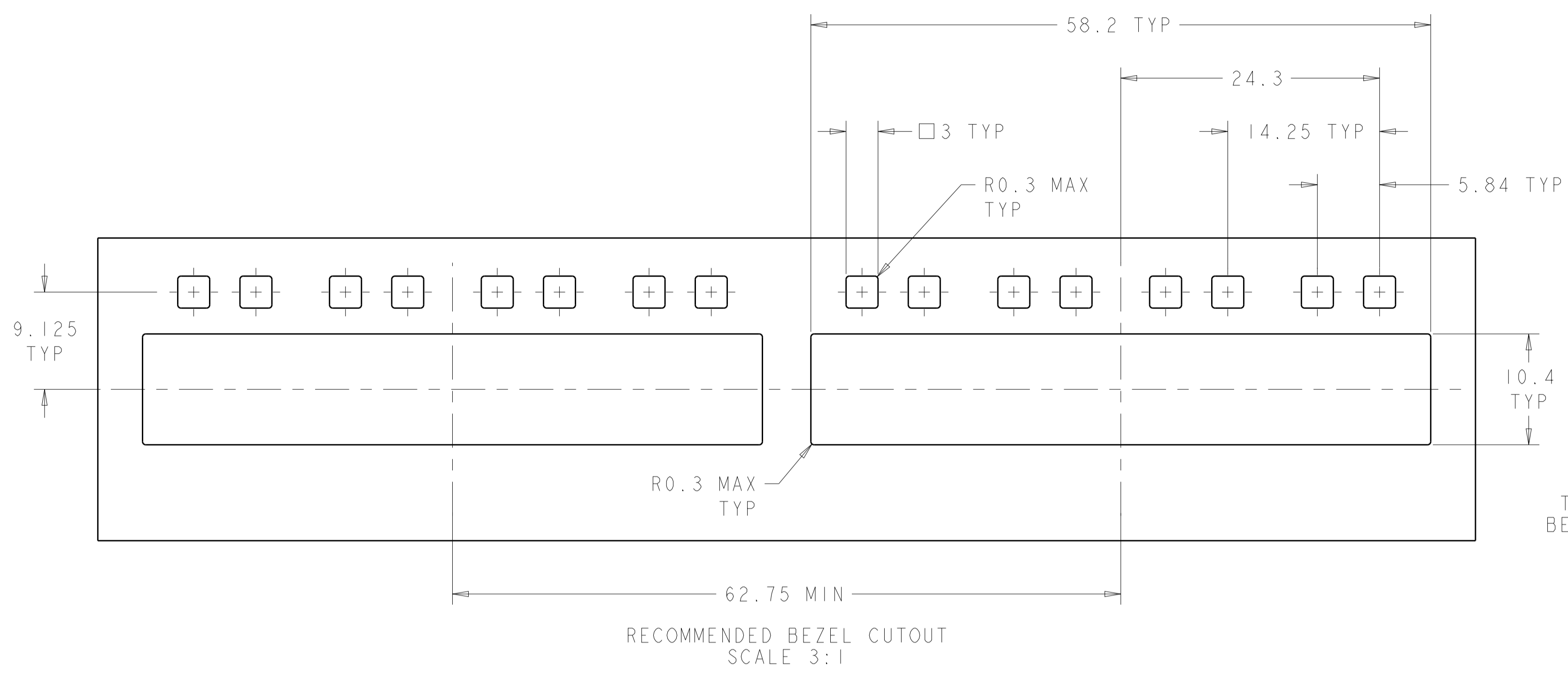

2110570-1  
MOUNTED ON PC BOARD SHOWN  
THRU RECOMMENDED BEZEL

THIS DRAWING IS A CONTROLLED DOCUMENT.		OWN: Z.M. BEAM 13APR2009	TE Connectivity
DIMENSIONS: mm		CHK: M.R. SCHMITT 13APR2009	
TOLERANCES UNLESS OTHERWISE SPECIFIED:		APPV: R.H. WERTZ 13APR2009	NAME: SFP+ 1X4 CAGE ASSEMBLY, PRESS FIT, EMI GASKET, W/ REDUCED LENGTH SQUARE LIGHT PIPES
0 PLC ±0.1	1 PLC ±0.1	PRODUCT SPEC: 108-2364	SIZE: A100779
2 PLC ±0.1	3 PLC ±0.1	APPLICATION SPEC: 114-13120	CAGE CODE: C=2110570
4 PLC ±0.1	ANGLES ±1°	WEIGHT: -	RESTRICTED TO: -
MATERIAL: -	FINISH: -	Customer Drawing	SCALE: 5:1 SHEET 2 OF 3 REV D