

THIS DRAWING IS UNPUBLISHED. RELEASED FOR PUBLICATION  
 © COPYRIGHT - By - ALL RIGHTS RESERVED.

| LOC |     | DIST        |          | REVISIONS |      |    |  |
|-----|-----|-------------|----------|-----------|------|----|--|
| P   | LTR | DESCRIPTION | DATE     | DWN       | APVD |    |  |
| -   | -   | A           | RELEASED | 1-15-14   | CT   | WB |  |

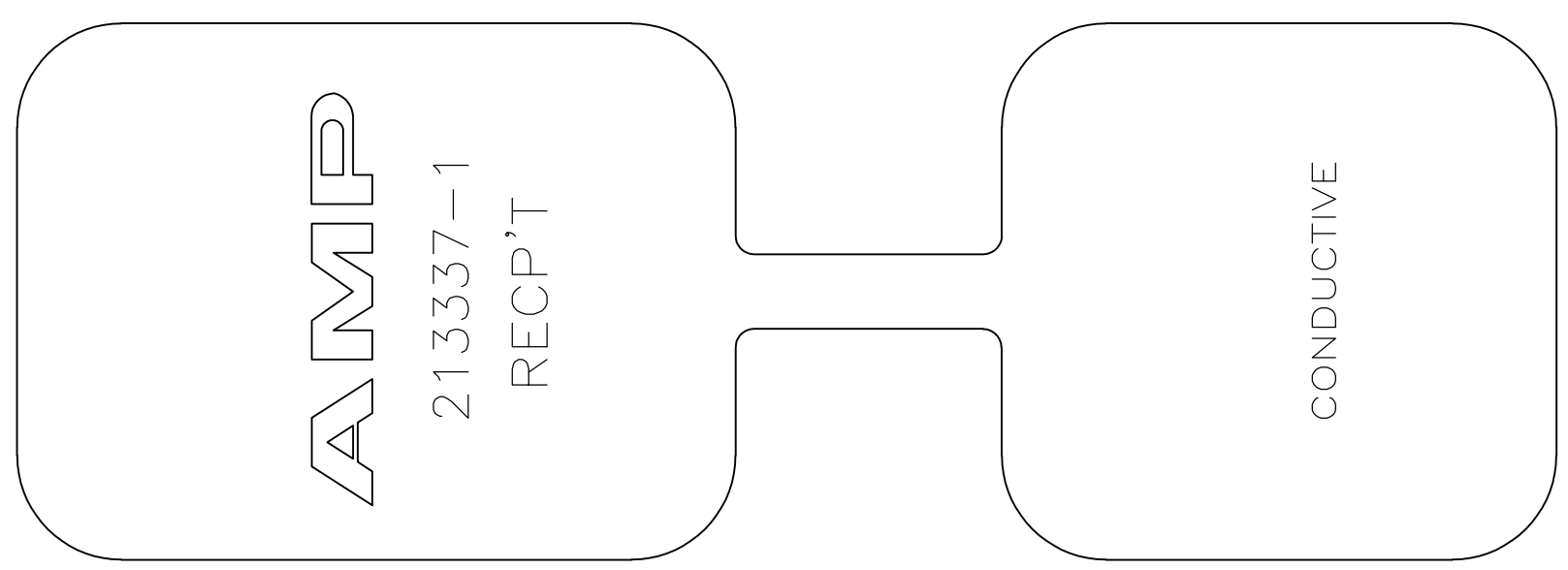
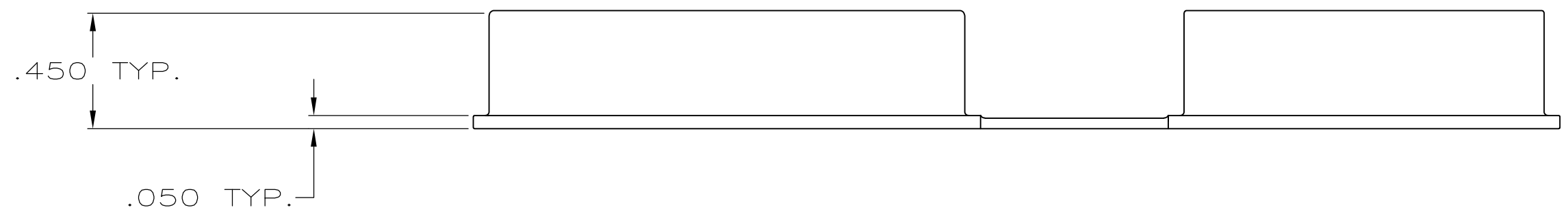
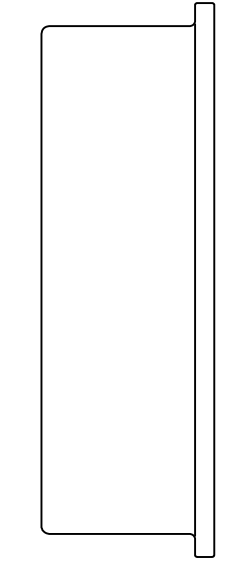
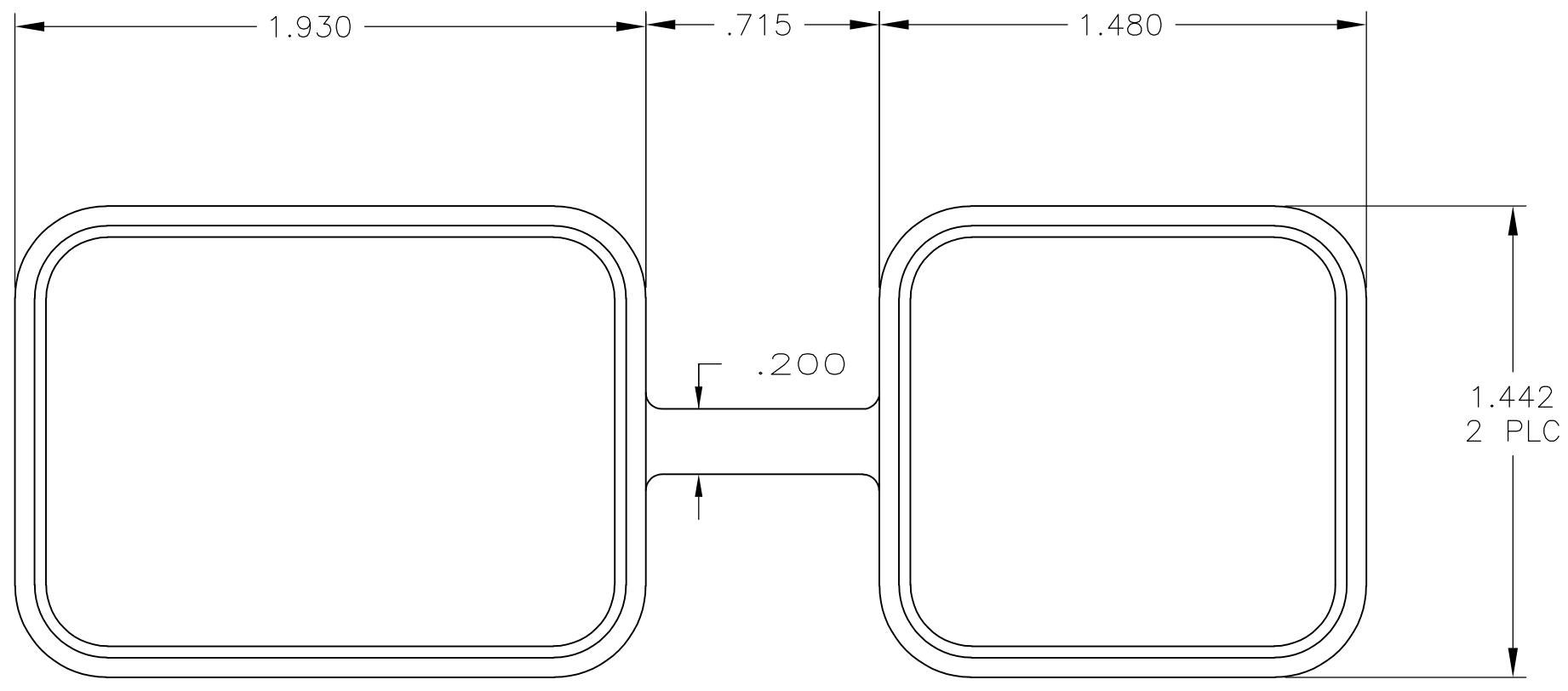

213337-1  
PART NUMBER

1. MATERIAL: POLYPROPYLENE, CONDUCTIVE, COLOR: BLACK.

|   |   |                  |            |         |       |                                   |       |           |       |            |          |               |   |      |       |   |   |        |   |   |              |   |  |
|---|---|------------------|------------|---------|-------|-----------------------------------|-------|-----------|-------|------------|----------|---------------|---|------|-------|---|---|--------|---|---|--------------|---|--|
| THIS DRAWING IS A CONTROLLED DOCUMENT.  |   | DWN              | C.C.THOMAS | 1-15-14 |       | TE Connectivity                   |       |           |       |            |          |               |   |      |       |   |   |        |   |   |              |   |  |
| DIMENSIONS: INCHES  |   | CHK              | W.BERNHART | 1-15-14 |       | NAME                              |       |           |       |            |          |               |   |      |       |   |   |        |   |   |              |   |  |
| TOLERANCES UNLESS OTHERWISE SPECIFIED:  |   | APVD             | W.BERNHART | 1-15-14 |       | DUST COVER, RECEPTACLE, ARINC 600 |       |           |       |            |          |               |   |      |       |   |   |        |   |   |              |   |  |
| <table border="1"> <tr><td>0 PLC</td><td>±</td><td>-</td></tr> <tr><td>1 PLC</td><td>±</td><td>-</td></tr> <tr><td>2 PLC</td><td>±</td><td>-</td></tr> <tr><td>3 PLC</td><td>±</td><td>.005</td></tr> <tr><td>4 PLC</td><td>±</td><td>-</td></tr> <tr><td>ANGLES</td><td>±</td><td>-</td></tr> </table> |   | 0 PLC            | ±          | -       |       | 1 PLC                             | ±     | -         | 2 PLC | ±          | -        | 3 PLC         | ± | .005 | 4 PLC | ± | - | ANGLES | ± | - | PRODUCT SPEC | - |  |
| 0 PLC   | ± | -                |            |         |       |                                   |       |           |       |            |          |               |   |      |       |   |   |        |   |   |              |   |  |
| 1 PLC   | ± | -                |            |         |       |                                   |       |           |       |            |          |               |   |      |       |   |   |        |   |   |              |   |  |
| 2 PLC   | ± | -                |            |         |       |                                   |       |           |       |            |          |               |   |      |       |   |   |        |   |   |              |   |  |
| 3 PLC   | ± | .005             |            |         |       |                                   |       |           |       |            |          |               |   |      |       |   |   |        |   |   |              |   |  |
| 4 PLC   | ± | -                |            |         |       |                                   |       |           |       |            |          |               |   |      |       |   |   |        |   |   |              |   |  |
| ANGLES  | ± | -                |            |         |       |                                   |       |           |       |            |          |               |   |      |       |   |   |        |   |   |              |   |  |
| MATERIAL  | - | APPLICATION SPEC | -          |         |       | SIZE                              | A2    | CAGE CODE | 00779 | DRAWING NO | C=213337 | RESTRICTED TO | - |      |       |   |   |        |   |   |              |   |  |
| FINISH  |   | WEIGHT           | -          |         | SCALE | 2:1                               | SHEET | 1 of 1    | REV   | A          |          |               |   |      |       |   |   |        |   |   |              |   |  |
| CUSTOMER DRAWING  |   |                  |            |         |       |                                   |       |           |       |            |          |               |   |      |       |   |   |        |   |   |              |   |  |