

LOC		DIST		REVISIONS			
P	LTR	DESCRIPTION	DATE	DWN	APVD	SS	GS
A		REVISED PER 063B-0095-05	4/8/05	SS	GS		

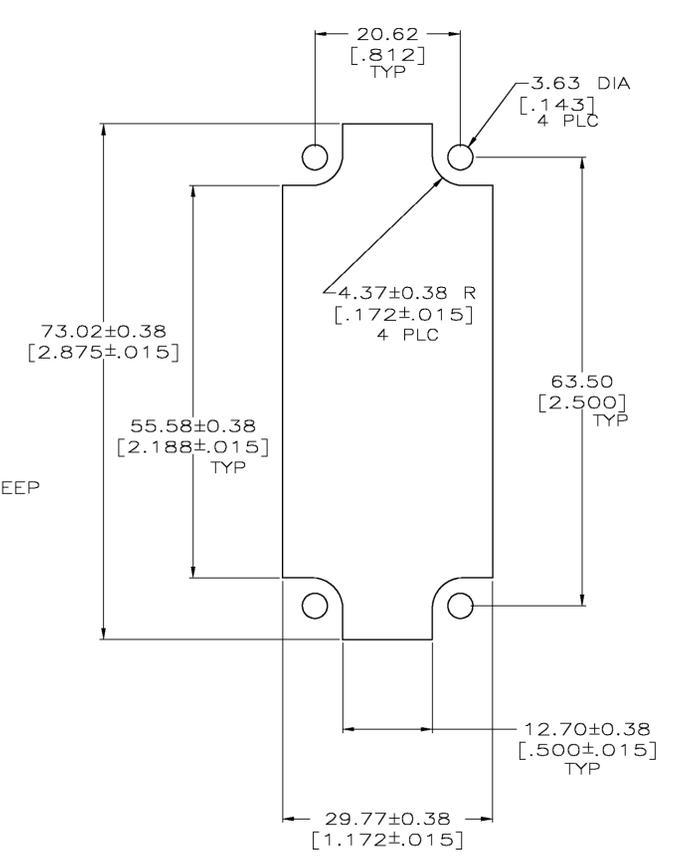

RECOMMENDED PANEL CUTOUT

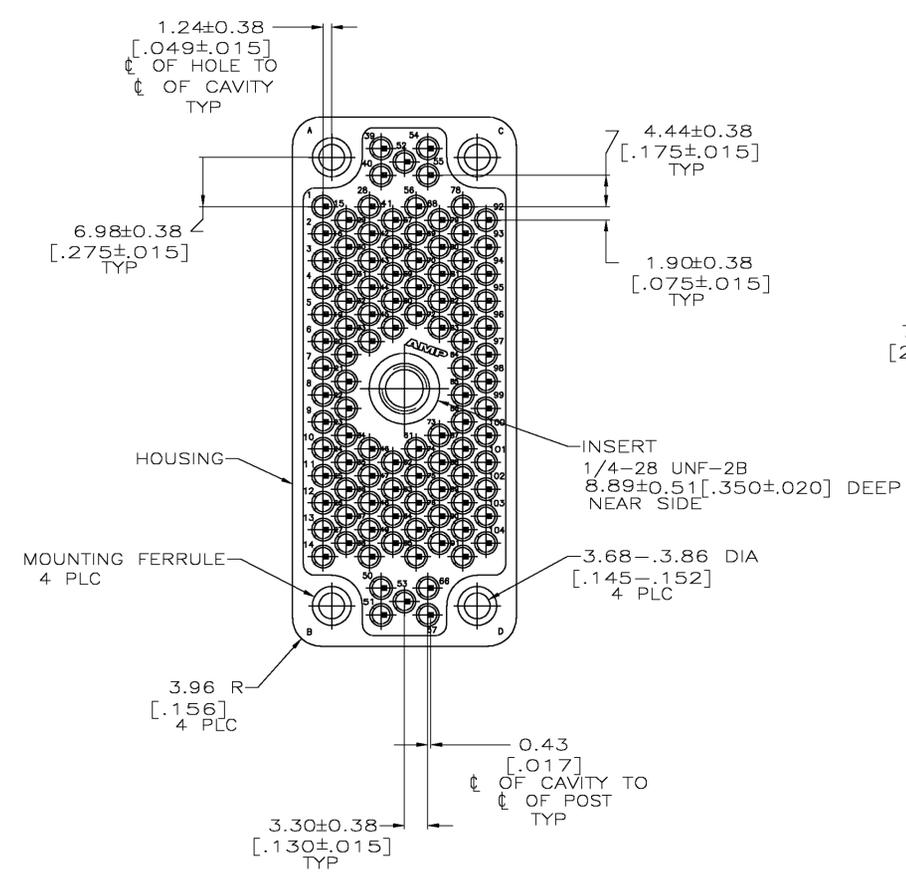
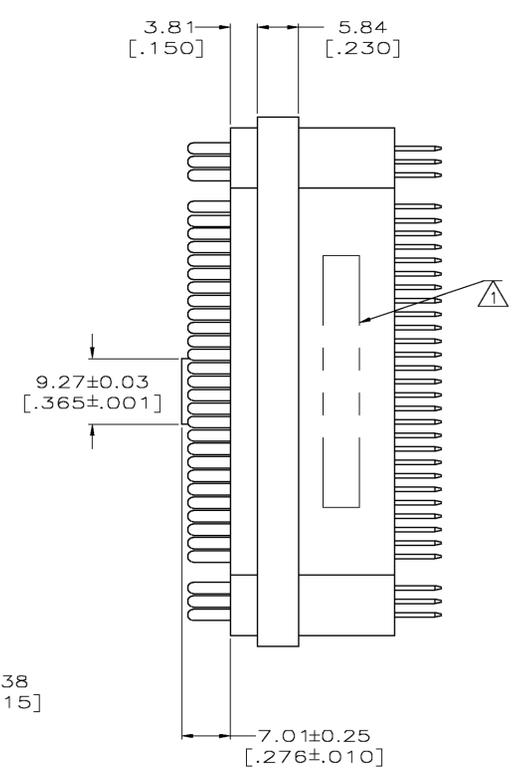
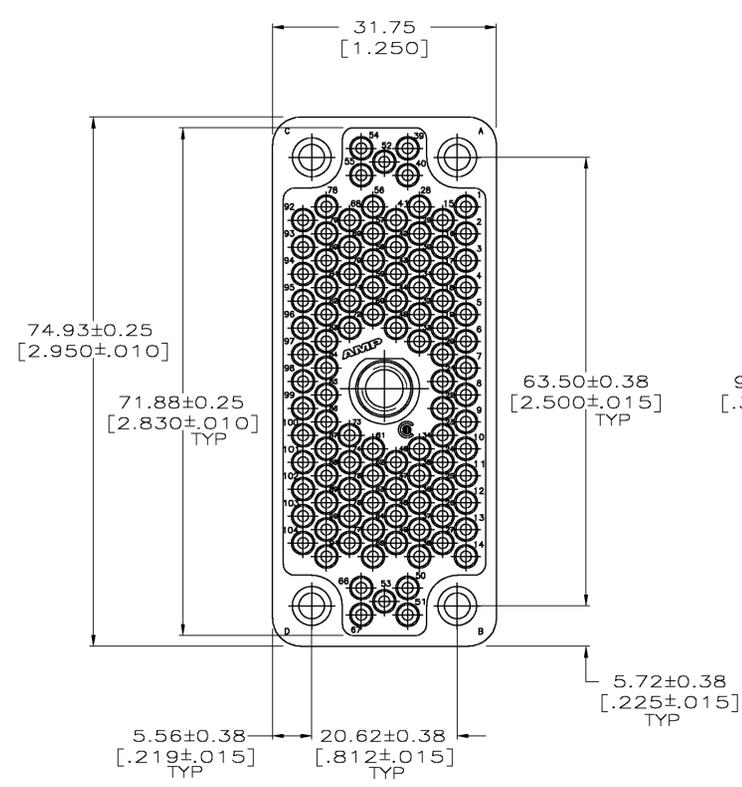
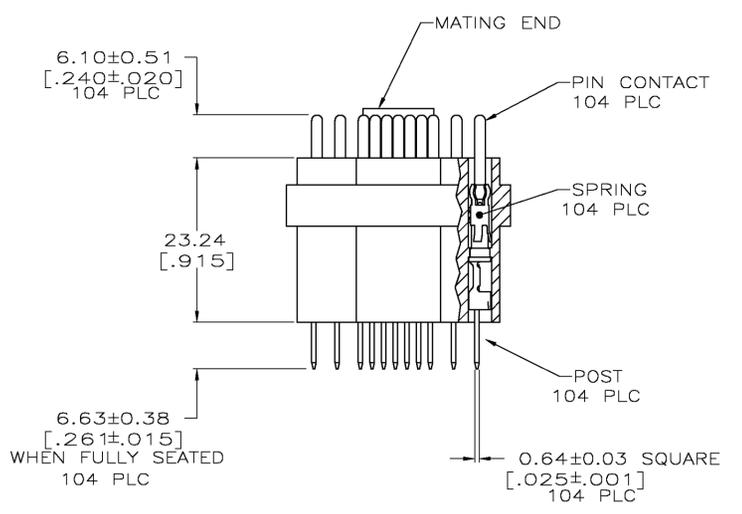

- △ THIS AREA MARKED WITH AMP, 213763-1, AND DATE CODE ON EITHER SIDE.
- 2. POSTS ARE SEMI-AUTOMATICALLY WIREABLE WITH 24 MAX AWG WIRE.
- △ HOUSING: DIALYL PHTHALATE PER MIL-M-14-F TYPE SDG-F, BLUE; INSERT, MOUNTING FERRULES AND SPRINGS: STAINLESS STEEL; POSTS AND PIN CONTACTS: BRASS.
- △ POSTS: 25.4um[.000100] MIN TIN-LEAD OVER 2.54um[.000100] MIN COPPER. PIN CONTACTS: 0.76um[.000030] MIN GOLD FOR A LENGTH OF 6.35[.250] FROM MATING END, GOLD FLASH ON THE REMAINDER, BOTH OVER 1.27um[.000050] MIN NICKEL.
- △ GOLD PLATE PER MIL-G-45204, NICKEL PLATE PER QQ-N-290, TIN-LEAD AND TIN PLATE PER MIL-T-10727.
- △ POSTS: 25.4um[.000100] MIN TIN OVER 2.54um[.000100] MIN COPPER. PIN CONTACTS: 0.76um[.000030] MIN GOLD FOR A LENGTH OF 6.35[.250] FROM MATING END, GOLD FLASH ON THE REMAINDER, BOTH OVER 1.27um[.000050] MIN NICKEL.

△	213763-2
△	213763-1
FINISH	PART NUMBER

THIS DRAWING IS A CONTROLLED DOCUMENT.

DIMENSIONS: mm [INCHES]	TOLERANCES UNLESS OTHERWISE SPECIFIED: 0 PLC ± 1 PLC ± 2 PLC ± 0.13[.005] 3 PLC ± 4 PLC ± ANGLES ± FINISH	DWN J McCLINTON GJK R STONE	9-30-92 10-1-92	tyco Electronics	Tyco Electronics Corporation Harrisburg, Pa 17105-3608
		NAME PLUG ASSEMBLY, 104 POSN. W/CENTER INSERT, POSTED, M SERIES	PRODUCT SPEC 108-10001	SIZE A1	CAGE CODE 00779
MATERIAL -		RESTRICTED TO	DRAWING NO 213763	SCALE 2:1	SHEET 1 OF 1
CUSTOMER DRAWING		REV A			