

LOC		DIST		REVISIONS			
P	LTN	DESCRIPTION	DATE	DWN	APVD		
A1		REVISED PER ECR-18-009294	14JUN2018	JS	DD		

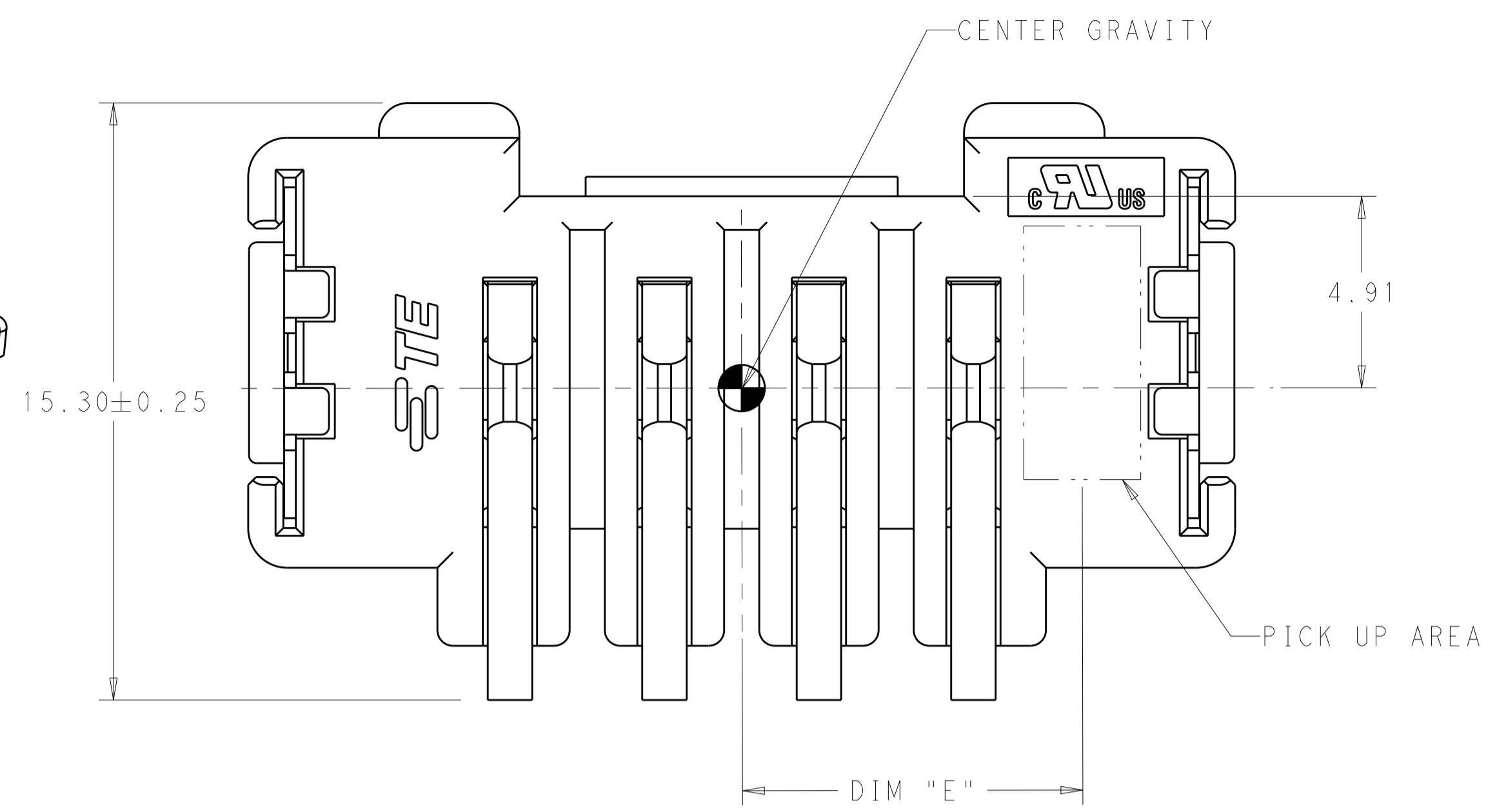

- MATERIAL AND FINISH:
 -HOUSING: LCP, COLOR: NATURAL
 -CONTACTS: COPPER ALLOY, FINISH: Sn OVER Ni
 -BOARD LOCKS: COPPER ALLOY, FINISH: Sn OVER Ni
 - MUST COMPLY WITH DIRECTIVE 2002/95/EC (ROHS)
 - PACKAGE IN TAPE & REEL PER ETA-48I SPECIFICATIONS
 DIAMETER OF REEL TO BE 330mm.
 - THIS PRODUCT HAS NOT COMPLETED VALIDATION TESTING.
- △ VACUUM PICK UP TAPE

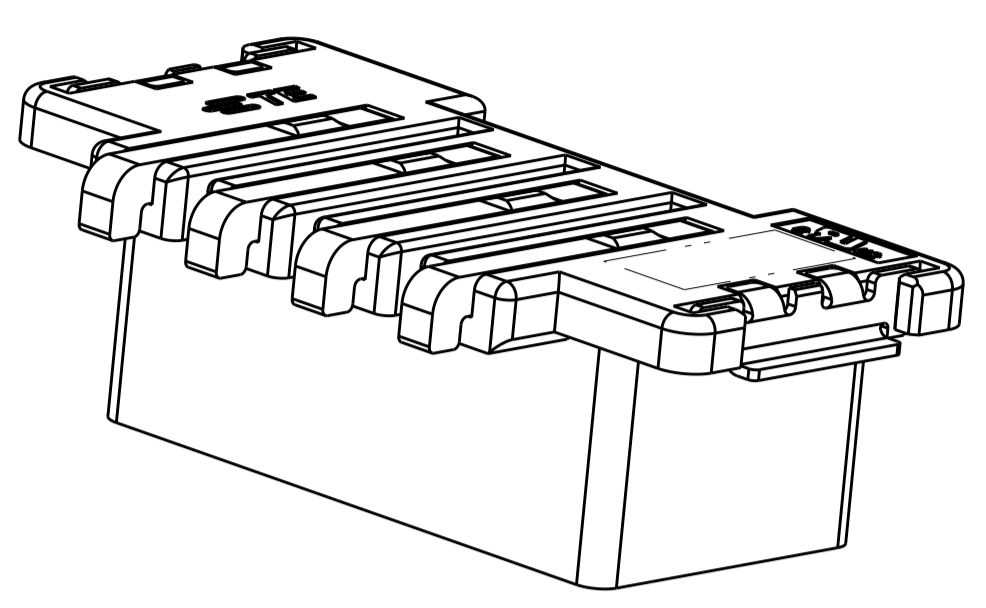
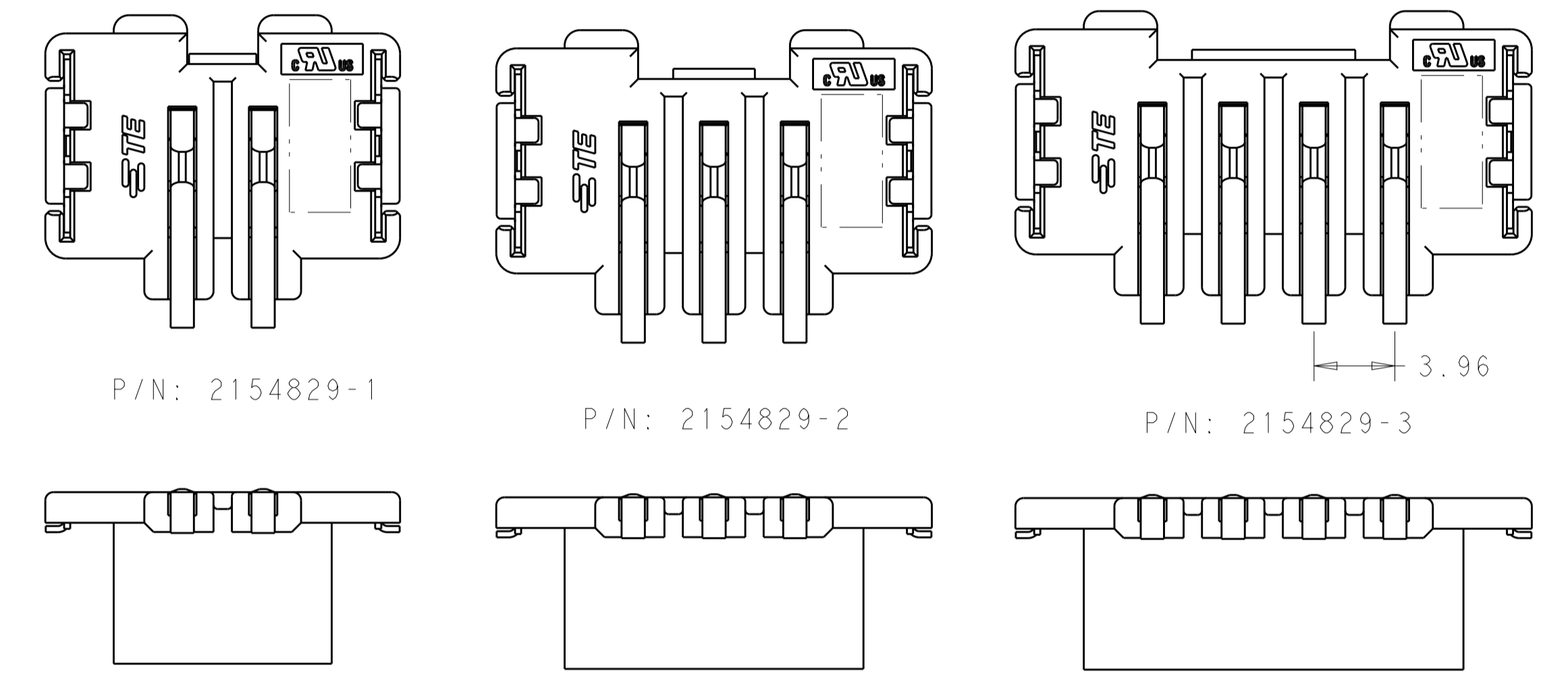
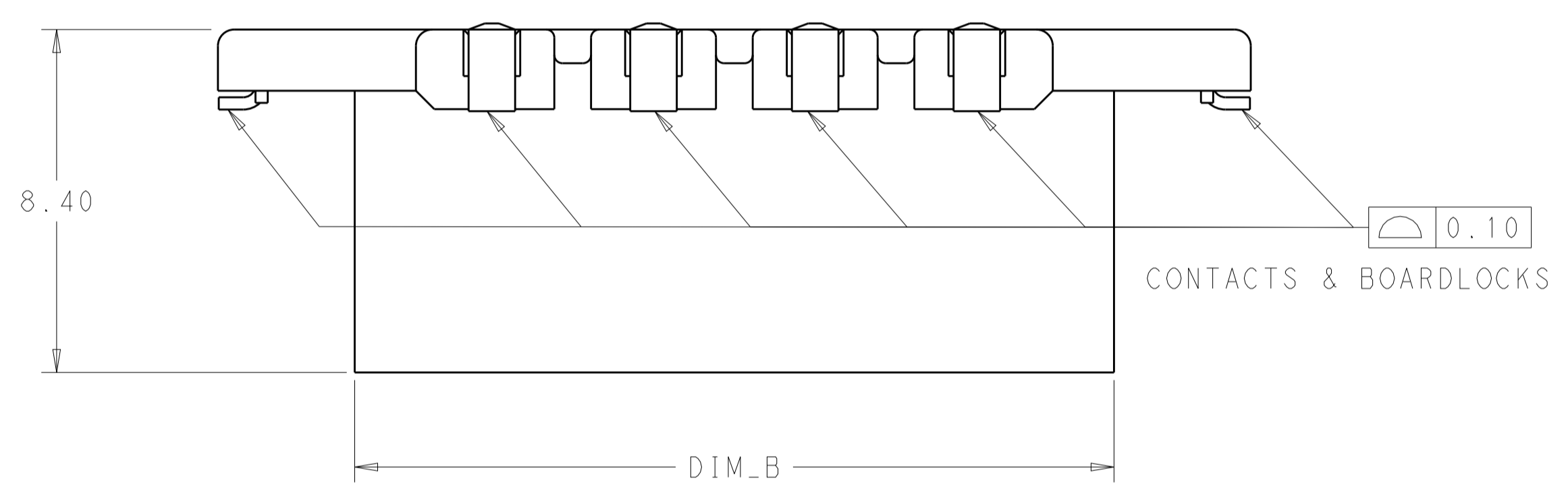
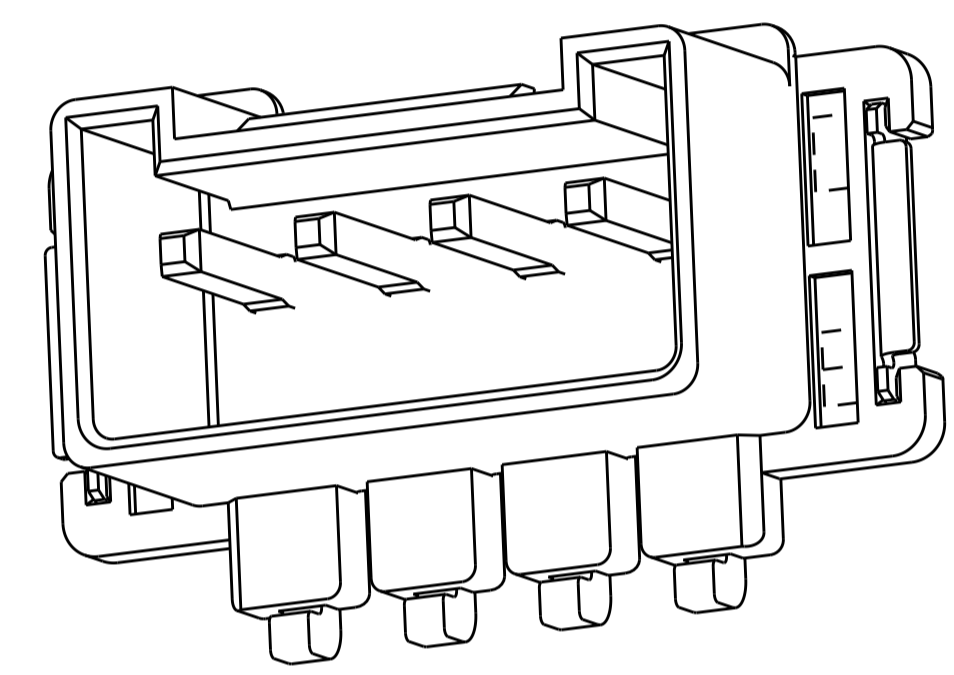

ISOMETRIC VIEW
(P/N: 2154829-3 SHOWN)

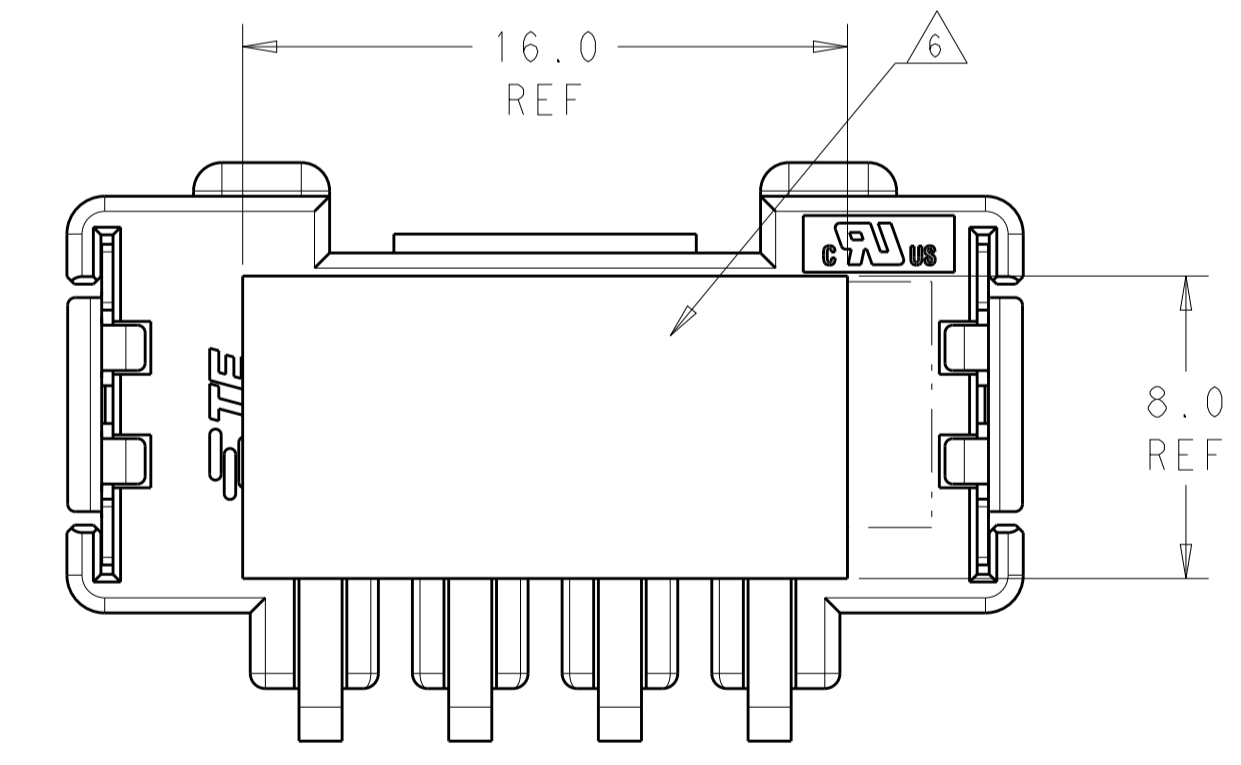
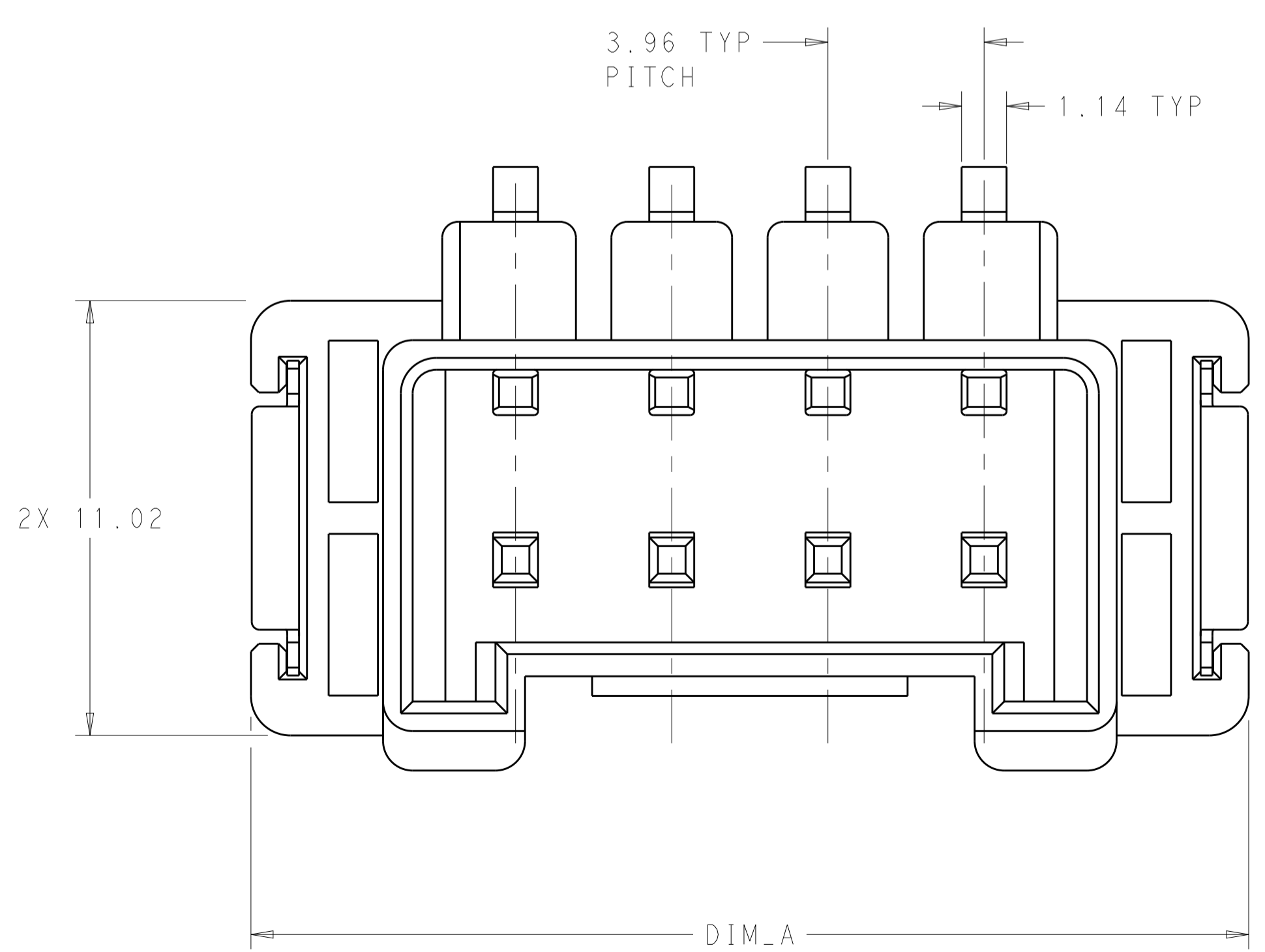
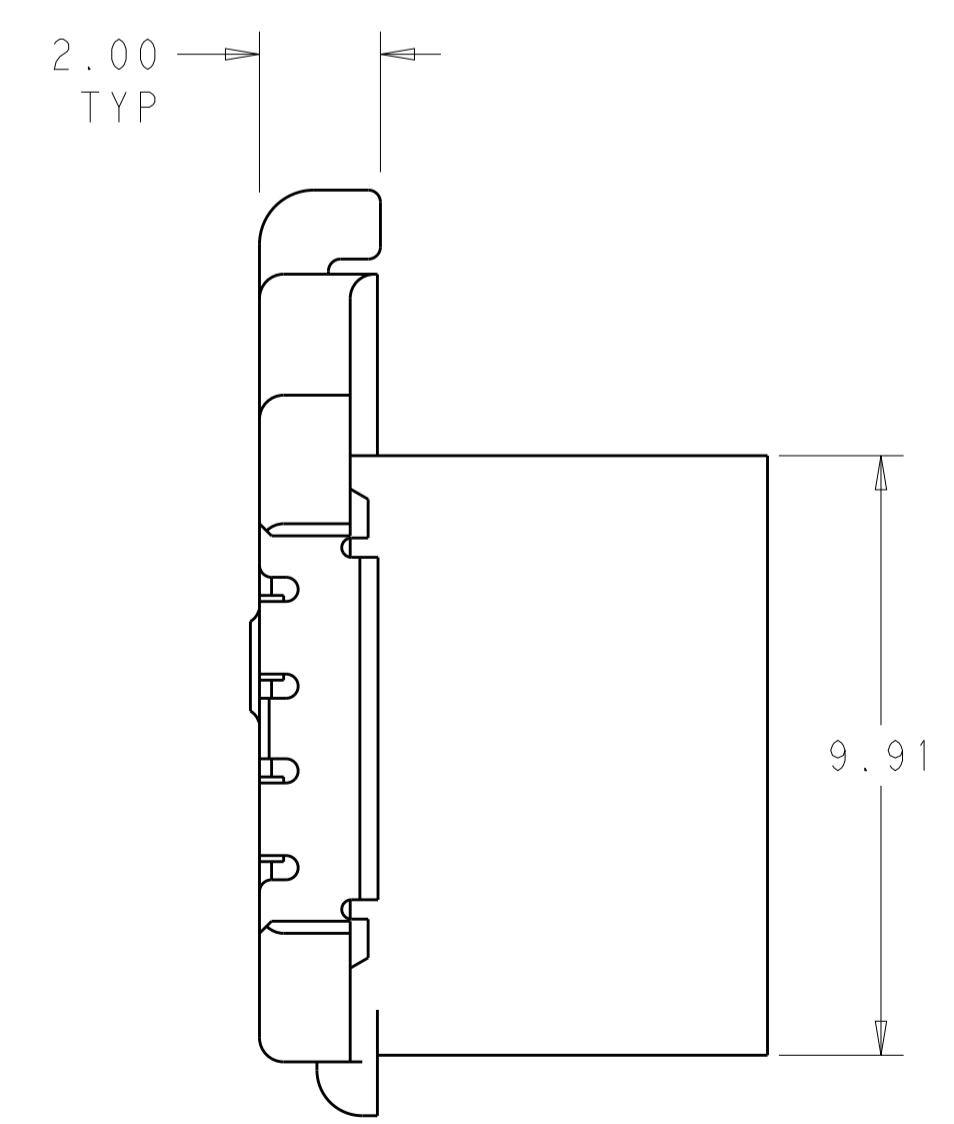

YES	8.73	12.04	19.00	18.60	25.30	4	1-2154829-3
NO	8.73	12.04	19.00	18.60	25.30	4	2154829-3
NO	6.75	10.06	15.00	14.64	21.34	3	2154829-2
NO	4.77	8.08	11.00	10.68	17.38	2	2154829-1
△ TAPE	DIM_E	DIM_D	DIM_C	DIM_B	DIM_A	NO. OF POSN.	PART NUMBER

THIS DRAWING IS A CONTROLLED DOCUMENT.		DWN: G. PETERS 01FEB2012	TE Connectivity	
DIMENSIONS: mm		CHK: C. GINGRICH 01FEB2012		
TOLERANCES UNLESS OTHERWISE SPECIFIED:		APVD: C. GINGRICH	NAME: ASSEMBLY INVERTED THRU BOARD 2 THRU 4 POSITIONS 3.96 PITCH	
0 PLC	±	PRODUCT SPEC	SIZE: CAGE CODE DRAWING NO	
1 PLC	±	108-133000	RESTRICTED TO	
2 PLC	±0.13	APPLICATION SPEC	A100779C=2154829	
3 PLC	±	114-32030	SCALE: 5:1 SHEET 1 OF 3 REV: A1	
4 PLC	±	WEIGHT	Customer Drawing	
ANGLES	±			
FINISH				

LOC		DIST		REVISIONS			
				REV	DATE	BY	APPV
-	-	-	-	-	-	-	-
-	-	-	-	-	SEE SHEET 1	-	-

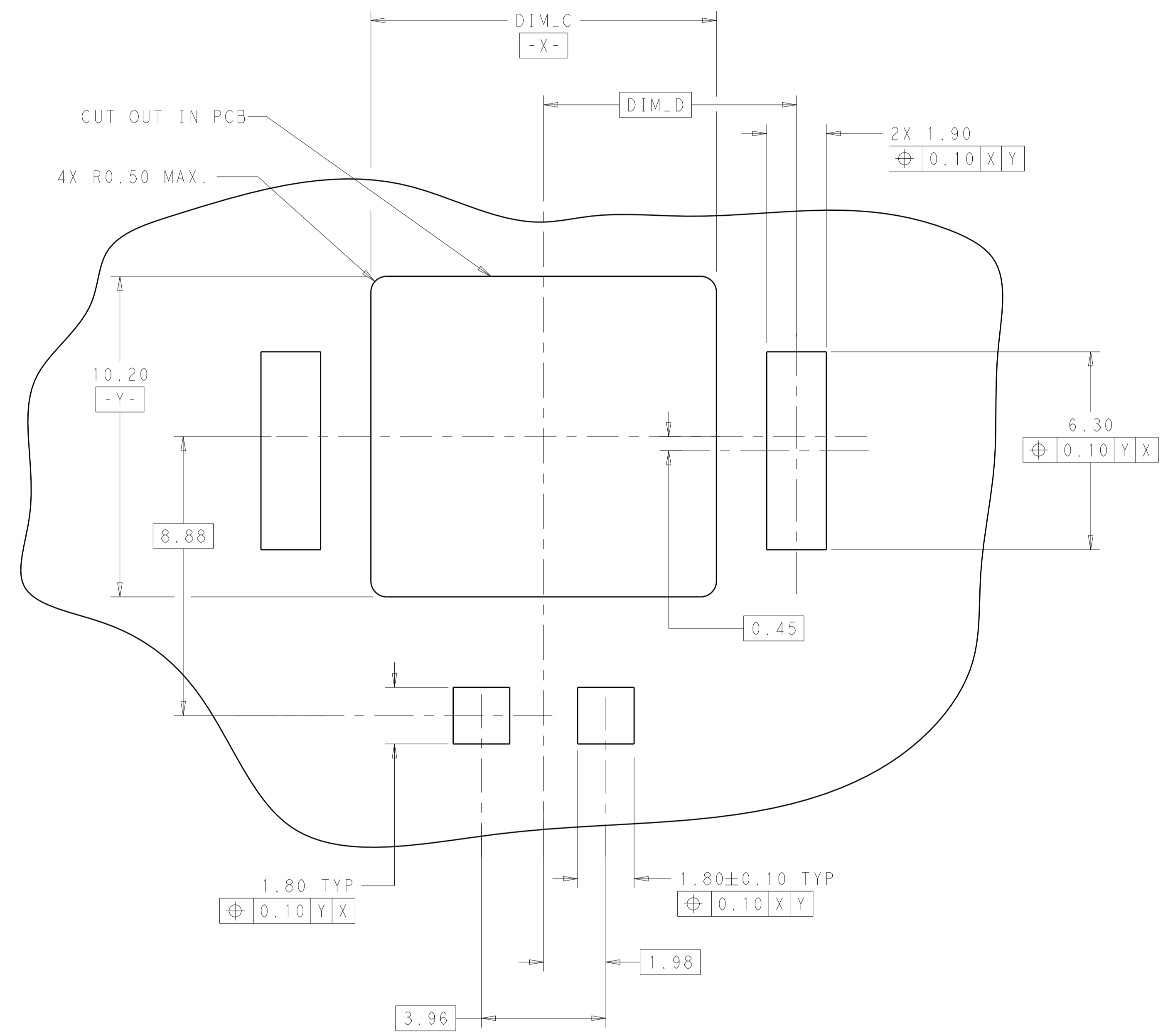

RECOMMENDED PCB LAYOUT
 EVEN NUMBER POSITIONS SHOWN
 SCALE 10:1

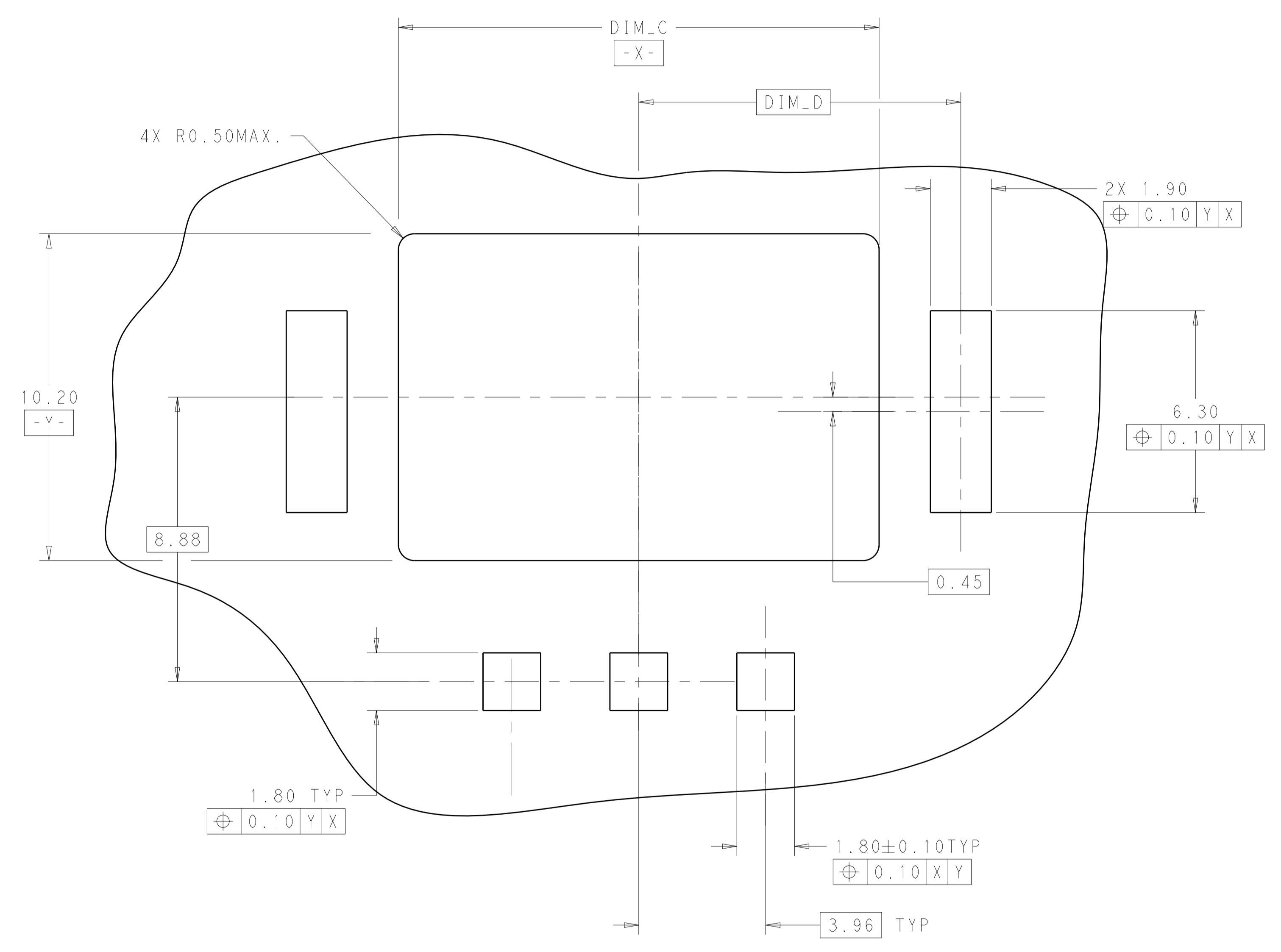

RECOMMENDED PCB LAYOUT
 ODD NUMBER POSITIONS SHOWN
 SCALE 10:1

THIS DRAWING IS A CONTROLLED DOCUMENT.		OWN G. PETERS 01FEB2012	TE Connectivity
DIMENSIONS: mm		CHK C. GINGRICH 01FEB2012	
TOLERANCES UNLESS OTHERWISE SPECIFIED:		APVD C. GINGRICH	NAME ASSEMBLY INVERTED THRU BOARD
0 PLC ±	1 PLC ±0.13	PRODUCT SPEC 108-133000	2 THRU 4 POSITIONS 3.96 PITCH
2 PLC ±	3 PLC ±	APPLICATION SPEC 114-32030	SIZE CAGE CODE DRAWING NO
4 PLC ±	ANGLES ±	WEIGHT	A100779C=2154829
MATERIAL	FINISH	Customer Drawing	RESTRICTED TO
		SCALE 1:1	SHEET 2 OF 3
			REV A1