

P	LTR	DESCRIPTION	DATE	DWN	APVD
	D	REV PER ECO 20-005188	4-20-20	CT	DM

1 MATERIAL AND FINISH:
 CONNECTOR SHELL: 6061-T6 ALUMINUM - SEE TABLE FOR PLATING
 QUADRAX RETENTION CLIP: SILVER PLATED STAINLESS STEEL
 JAM NUT: 6061-T6 ALUMINUM - SEE TABLE FOR PLATING
 FLANGE SEALING O-RING: VITON RUBBER
 INTERFACIAL SEAL: SILICONE RUBBER

2 PART IS MARKED WITH TE CONNECTIVITY PART NUMBER (SEE TABLE),
 TE, TE CAGE CODE (00779) AND DATE CODE.

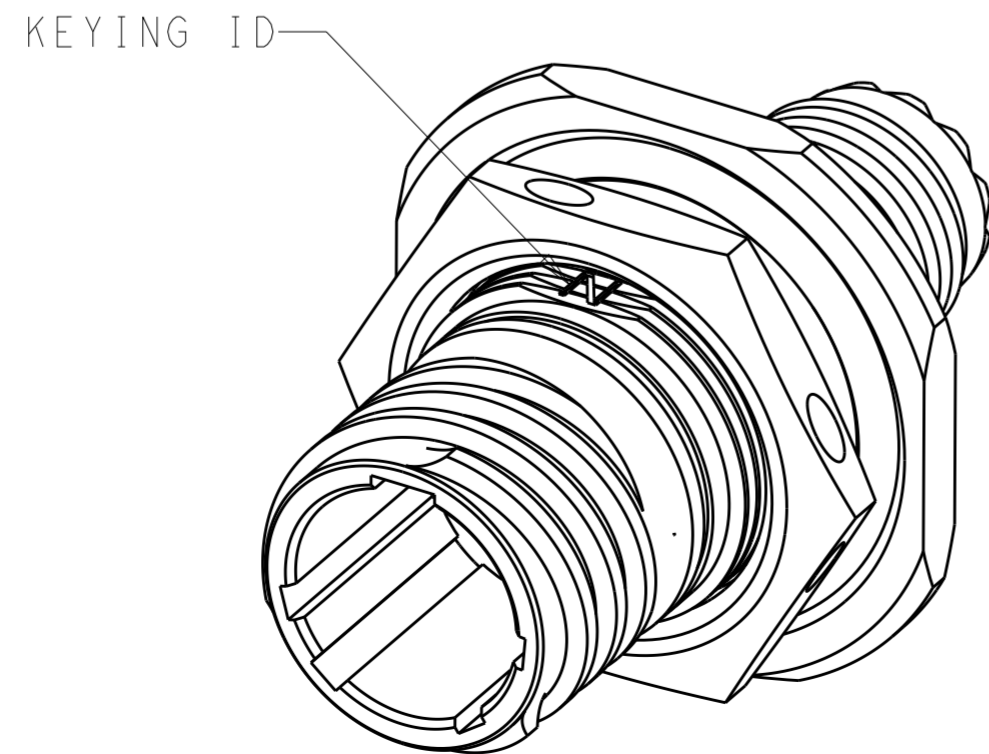
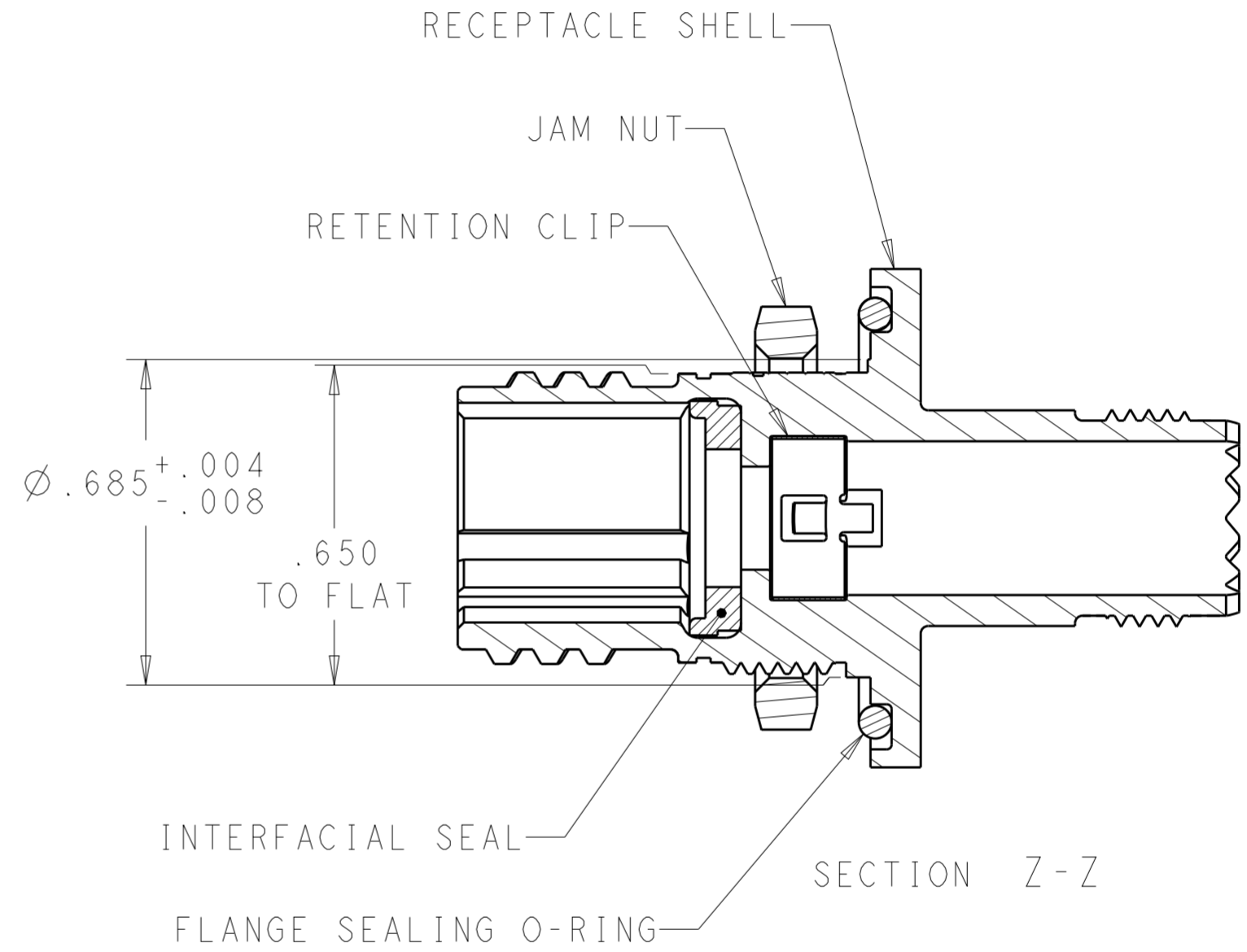
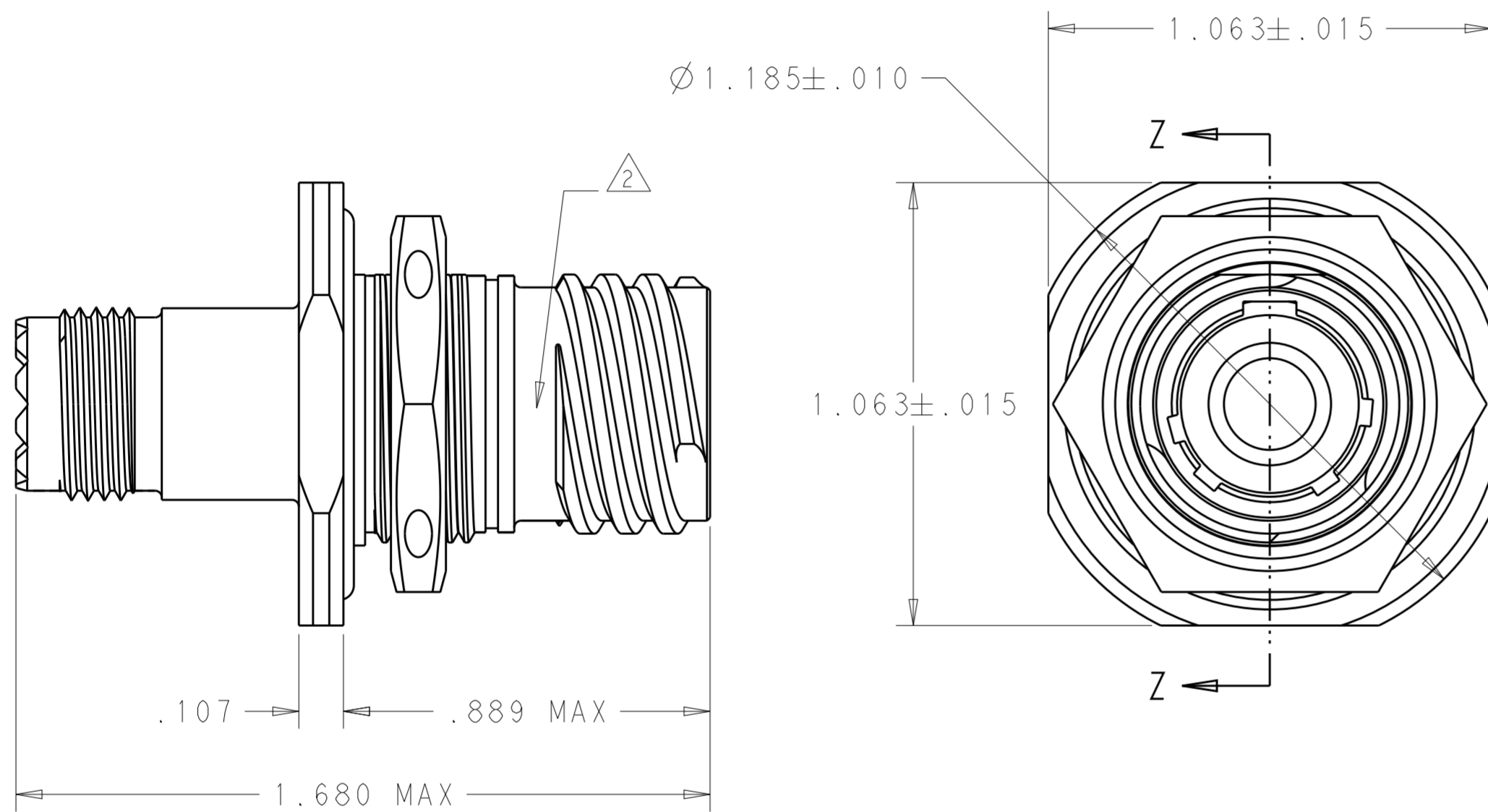

OLIVE DRAB	"B" KEY	2157694-6
OLIVE DRAB	"A" KEY	2157694-5
OLIVE DRAB	"N" KEY	2157694-4
NICKEL	"B" KEY	2157694-3
NICKEL	"A" KEY	2157694-2
NICKEL	"N" KEY	2157694-1
FINISH	38999 KEYING	PART NUMBER

THIS DRAWING IS A CONTROLLED DOCUMENT.		DWN K. GLATFELTER 06OCT2011	TE Connectivity	
DIMENSIONS: INCHES		CHK D. MILLER 06OCT2011		
TOLERANCES UNLESS OTHERWISE SPECIFIED:		APVD D. MILLER 06OCT2011	NAME RECEPTACLE, 38999 SERIES III, SIZE 9, JAM NUT STYLE, SINGLE QUADRAX	
0 PLC ±	1 PLC ±	PRODUCT SPEC	SIZE CAGE CODE DRAWING NO	
2 PLC ±	3 PLC ±.005	APPLICATION SPEC	A200779 C-2157694	
4 PLC ±	ANGLES ±	WEIGHT	RESTRICTED TO	
FINISH		CUSTOMER DRAWING	SCALE 3:1	SHEET 1 OF 2 REV D

P	LTR	DESCRIPTION	DATE	DWN	APVD
-		SEE SHEET 1	-	-	-

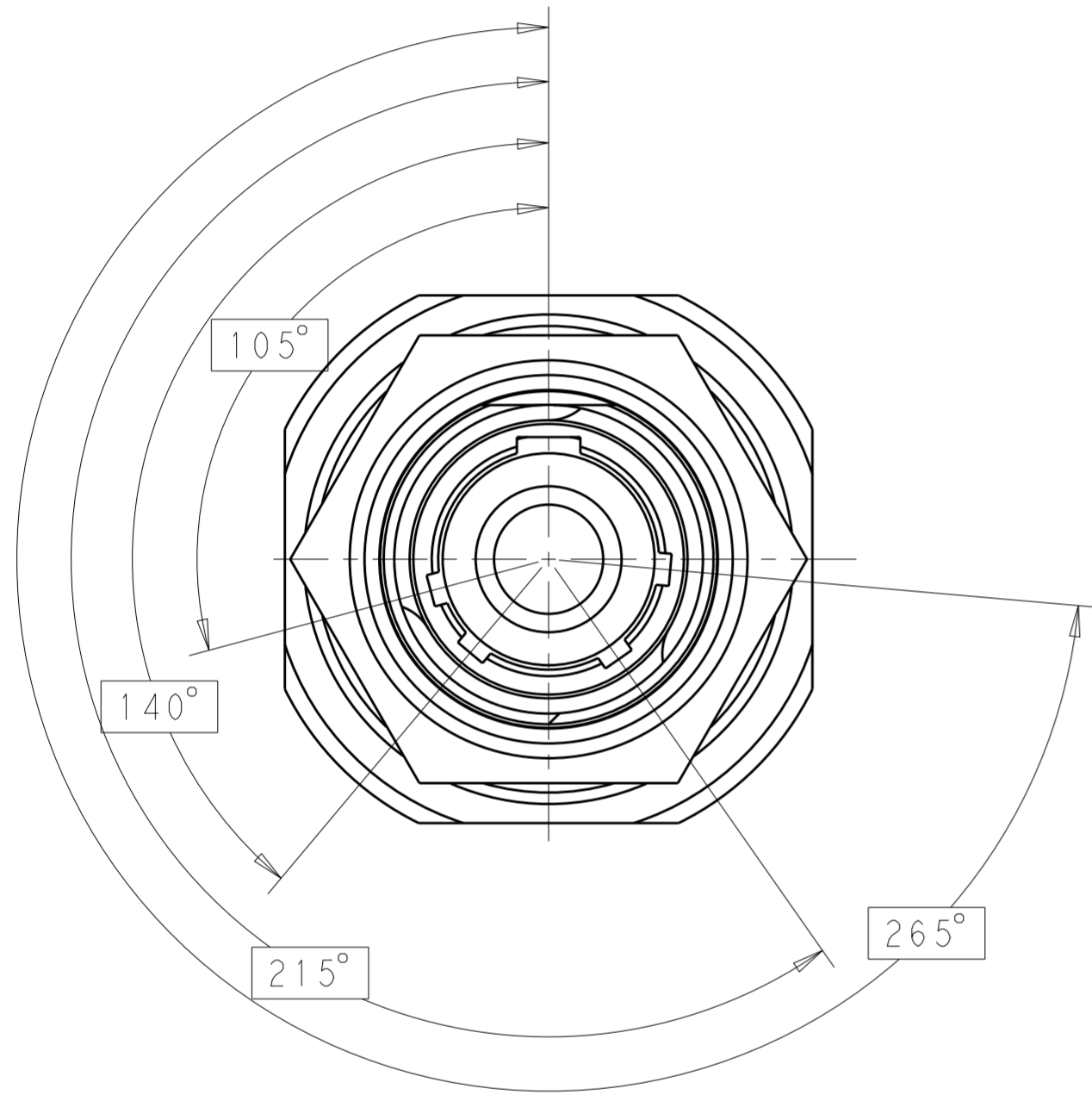

"N" 38999 KEYING

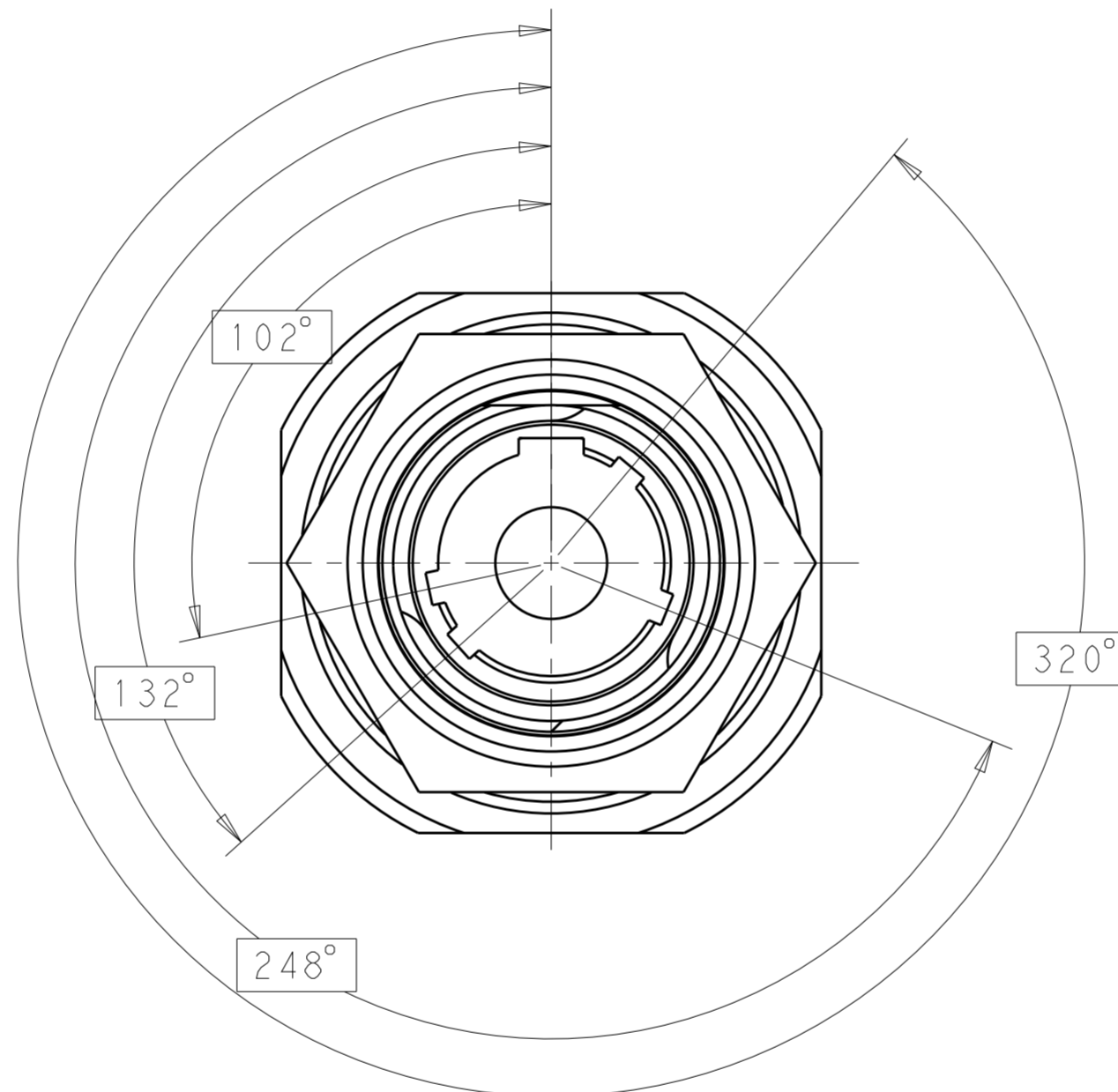

"A" 38999 KEYING

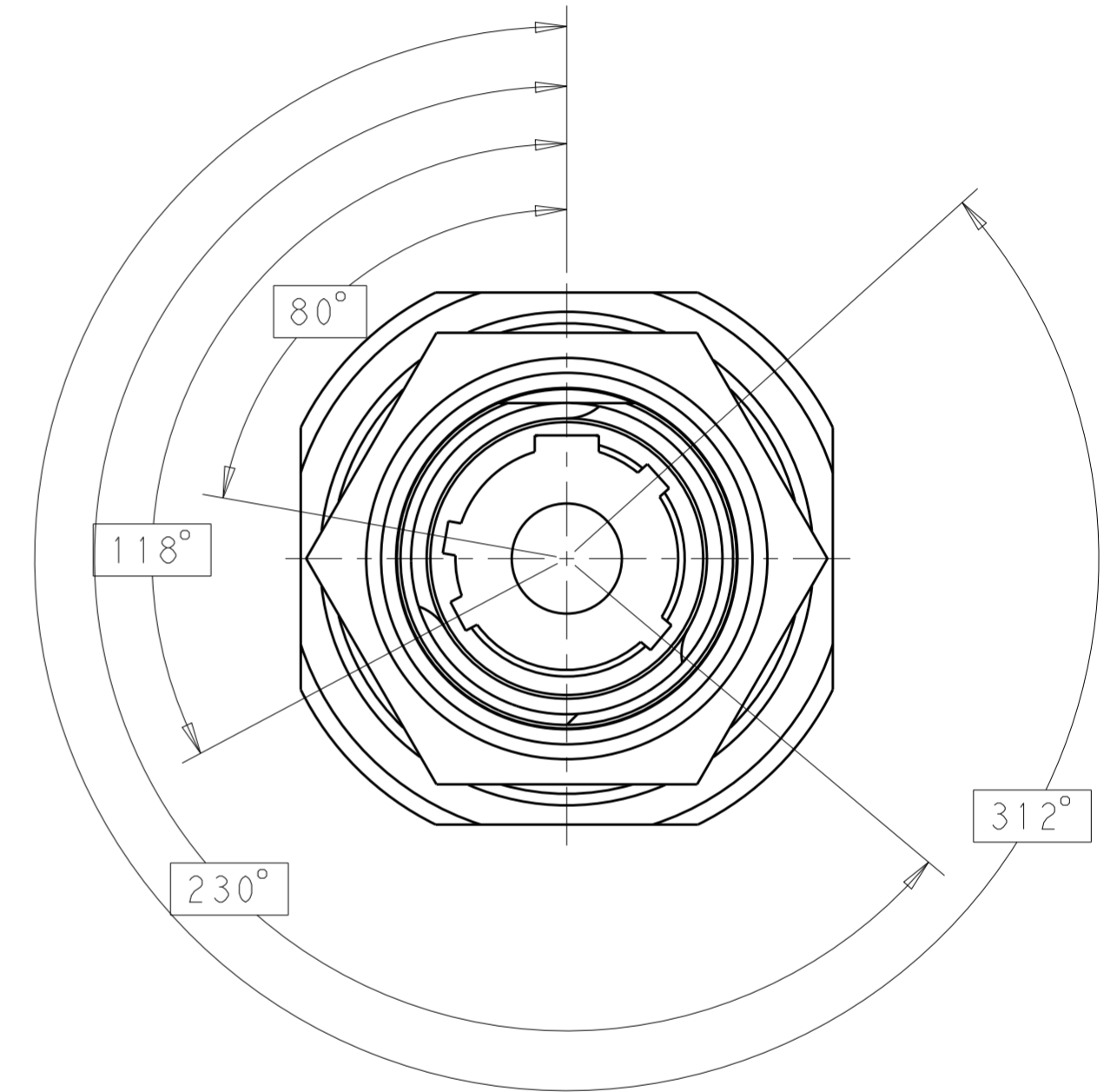

"B" 38999 KEYING

THIS DRAWING IS A CONTROLLED DOCUMENT.		DWN K. GLATFELTER 06OCT2011	 TE Connectivity	
DIMENSIONS: INCHES		CHK D. MILLER 06OCT2011		
TOLERANCES UNLESS OTHERWISE SPECIFIED:		APVD D. MILLER 06OCT2011	NAME RECEPTACLE, 38999 SERIES III, SIZE 9, JAM NUT STYLE, SINGLE QUADRAX	
0 PLC ±	1 PLC ±	PRODUCT SPEC	SIZE	CAGE CODE
2 PLC ±	3 PLC ±	APPLICATION SPEC	A2	00779
4 PLC ±	ANGLES ±	WEIGHT	DRAWING NO	RESTRICTED TO
FINISH	FINISH	CUSTOMER DRAWING	C-2157694	
MATERIAL material_2	finish_spec_2	SCALE 3:1	SHEET 2 OF 2	REV D